



**NONRESIDENT  
TRAINING  
COURSE**



May 1999

---

# **Construction Mechanic Basic, Volume 2**

**NAVEDTRA 14273**

Although the words “he,” “him,” and “his” are used sparingly in this course to enhance communication, they are not intended to be gender driven or to affront or discriminate against anyone.

## PREFACE

By enrolling in this self-study course, you have demonstrated a desire to improve yourself and the Navy. Remember, however, this self-study course is only one part of the total Navy training program. Practical experience, schools, selected reading, and your desire to succeed are also necessary to successfully round out a fully meaningful training program.

**THE COURSE:** This self-study course is organized into subject matter areas, each containing learning objectives to help you determine what you should learn along with text and illustrations to help you understand the information. The subject matter reflects day-to-day requirements and experiences of personnel in the rating or skill area. It also reflects guidance provided by Enlisted Community Managers (ECMs) and other senior personnel, technical references, instructions, etc., and either the occupational or naval standards, which are listed in the *Manual of Navy Enlisted Manpower Personnel Classifications and Occupational Standards*, NAVPERS 18068.

**THE QUESTIONS:** The questions that appear in this course are designed to help you understand the material in the text.

**VALUE:** In completing this course, you will improve your military and professional knowledge. Importantly, it can also help you study for the Navy-wide advancement in rate examination. If you are studying and discover a reference in the text to another publication for further information, look it up.

*1999 Edition Prepared by  
CMC(SCW) Charles Lathan*

Published by  
NAVAL EDUCATION AND TRAINING  
PROFESSIONAL DEVELOPMENT  
AND TECHNOLOGY CENTER

**NAVSUP Logistics Tracking Number  
0504-LP-026-9040**

## **Sailor's Creed**

“I am a United States Sailor.

I will support and defend the Constitution of the United States of America and I will obey the orders of those appointed over me.

I represent the fighting spirit of the Navy and those who have gone before me to defend freedom and democracy around the world.

I proudly serve my country's Navy combat team with honor, courage and commitment.

I am committed to excellence and the fair treatment of all.”

# CONTENTS

CHAPTER	Page
1. Basic Automotive Electricity . . . . .	1-1
2. Automotive Electrical Circuits and Wiring . . . . .	2-1
3. Hydraulic and Pneumatic Systems. . . . .	3-1
4. Automotive Clutches, Transmissions, and Transaxles. . . . .	4-1
5. Drive Lines, Differentials, Drive Axles, and Power Train Accessories. . . . .	5-1
6. Construction Equipment Power Trains . . . . .	6-1
7. Brakes . . . . .	7-1
8. Automotive Chassis and Body . . . . .	8-1
APPENDIX	
I. Glossary. . . . .	AI-1
II. References Used to Develop This TRAMAN . . . . .	AII-1
INDEX . . . . .	INDEX-1

The Nonresident Training Course (NRTC) follows the Index

# **SUMMARY OF CONSTRUCTION MECHANIC BASIC**

## **VOLUME 1**

*Construction Mechanic Basic*, Volume 1, NAVEDTRA 14264, consists of chapters on Technical Administration; Principles of an Internal Combustion Engine; Construction of an Internal Combustion Engine; Gasoline Fuel Systems; Diesel Fuel Systems; and Cooling and Lubricating Systems.

## **VOLUME 2**

*Construction Mechanic Basic*, Volume 2, NAVEDTRA 14273, consists of chapters on Basic Automotive Electricity; Automotive Electrical Circuits and Wiring; Hydraulic and Pneumatic Systems; Automotive Clutches, Transmissions, and Transaxles; Drive Lines, Differentials, Drive Axles, and Power Train Accessories; Construction Equipment Power Trains; Brakes; and Automotive Chassis and Body.

## SAFETY PRECAUTIONS

Safety is a paramount concern for all personnel. Many of the Naval Ship's Technical Manuals, manufacturer's technical manuals, and every Planned Maintenance System (PMS) maintenance requirement card (MRC) include safety precautions. Additionally, OPNAVINST 5100.19 (series), Naval Occupational Safety and Health (NAVOSH) Program Manual for Forces Afloat, and OPNAVINST 5100.23 (series), NAVOSH Program Manual, provide safety and occupational health information. The safety precautions are for your protection and to protect equipment. Cautions and warnings of potentially hazardous situations or conditions are highlighted, where needed, in each chapter of this TRAMAN. Remember to be safety conscious at all times.

During equipment operation and preventive or corrective maintenance, the procedures may call for personal protective equipment (PPE), such as goggles, gloves, safety shoes, hard hats, hearing protection, and respirators. When specified, use of PPE is mandatory. You must select PPE appropriate for the job since the equipment is manufactured and approved for different levels of protection. Most machinery, spaces, and tools requiring you to wear hearing protection are posted with hazardous noise signs or labels. Eye hazardous areas requiring you to wear goggles or safety glasses are also posted. In areas where corrosive chemicals are mixed or used, an emergency eyewash station must be installed. Anytime a procedure does not specify the PPE, and you are not sure, ask your safety officer.

All lubricating agents, oil, cleaning material, and chemicals used in maintenance and repair are hazardous materials. Examples of hazardous materials are gasoline, coal distillates, and asphalt. Gasoline contains a small amount of lead and other toxic compounds. Ingestion of gasoline can cause lead poisoning. Coal distillates, such as benzene or naphthalene in benzol, are suspected carcinogens. Avoid all skin contact and do not inhale the vapors and gases from these distillates. Asphalt contains components suspected of causing cancer. Anyone handling asphalt must be trained to handle it in a safe manner.

Hazardous materials require careful handling, storage, and disposal. OPNAVINST 4110.2 (series), *Hazardous Material Control and Management*, contains detailed information on the hazardous material program. Additionally, PMS documentation provides hazard warnings or refers the maintenance man to the Hazardous Materials User's Guide. Material Safety Data Sheets (MSDS) also provide safety precautions for hazardous materials. All commands are required to have an MSDS for each hazardous material they have in their inventory; therefore, additional information is available from your command's Hazardous Material Coordinator.

Recent legislation and updated Navy directives implemented tighter constraints on environmental pollution and hazardous waste disposal. OPNAVINST 5090.1 (series), *Environmental and Natural Resources Program Manual*, provides detailed information. Your command must comply with federal, state, and local environmental regulations during any type of construction or demolition. Your supervisor will provide training on environmental compliance.

# INSTRUCTIONS FOR TAKING THE COURSE

## ASSIGNMENTS

The text pages that you are to study are listed at the beginning of each assignment. Study these pages carefully before attempting to answer the questions. Pay close attention to tables and illustrations and read the learning objectives. The learning objectives state what you should be able to do after studying the material. Answering the questions correctly helps you accomplish the objectives.

## SELECTING YOUR ANSWERS

Read each question carefully, then select the BEST answer. You may refer freely to the text. The answers must be the result of your own work and decisions. You are prohibited from referring to or copying the answers of others and from giving answers to anyone else taking the course.

## SUBMITTING YOUR ASSIGNMENTS

To have your assignments graded, you must be enrolled in the course with the Nonresident Training Course Administration Branch at the Naval Education and Training Professional Development and Technology Center (NETPDTC). Following enrollment, there are two ways of having your assignments graded: (1) use the Internet to submit your assignments as you complete them, or (2) send all the assignments at one time by mail to NETPDTC.

**Grading on the Internet:** Advantages to Internet grading are:

- you may submit your answers as soon as you complete an assignment, and
- you get your results faster; usually by the next working day (approximately 24 hours).

In addition to receiving grade results for each assignment, you will receive course completion confirmation once you have completed all the

assignments. To submit your assignment answers via the Internet, go to:

<http://courses.cnet.navy.mil>

**Grading by Mail:** When you submit answer sheets by mail, send all of your assignments at one time. Do NOT submit individual answer sheets for grading. Mail all of your assignments in an envelope, which you either provide yourself or obtain from your nearest Educational Services Officer (ESO). Submit answer sheets to:

COMMANDING OFFICER  
NETPDTC N331  
6490 SAUFLEY FIELD ROAD  
PENSACOLA FL 32559-5000

**Answer Sheets:** All courses include one “scannable” answer sheet for each assignment. These answer sheets are preprinted with your SSN, name, assignment number, and course number. Explanations for completing the answer sheets are on the answer sheet.

**Do not use answer sheet reproductions:** Use only the original answer sheets that we provide—reproductions will not work with our scanning equipment and cannot be processed.

Follow the instructions for marking your answers on the answer sheet. Be sure that blocks 1, 2, and 3 are filled in correctly. This information is necessary for your course to be properly processed and for you to receive credit for your work.

## COMPLETION TIME

Courses must be completed within 12 months from the date of enrollment. This includes time required to resubmit failed assignments.



## **PASS/FAIL ASSIGNMENT PROCEDURES**

If your overall course score is 3.2 or higher, you will pass the course and will not be required to resubmit assignments. Once your assignments have been graded you will receive course completion confirmation.

If you receive less than a 3.2 on any assignment and your overall course score is below 3.2, you will be given the opportunity to resubmit failed assignments. **You may resubmit failed assignments only once.** Internet students will receive notification when they have failed an assignment--they may then resubmit failed assignments on the web site. Internet students may view and print results for failed assignments from the web site. Students who submit by mail will receive a failing result letter and a new answer sheet for resubmission of each failed assignment.

## **COMPLETION CONFIRMATION**

After successfully completing this course, you will receive a letter of completion.

## **ERRATA**

Errata are used to correct minor errors or delete obsolete information in a course. Errata may also be used to provide instructions to the student. If a course has an errata, it will be included as the first page(s) after the front cover. Errata for all courses can be accessed and viewed/downloaded at:

<http://www.advancement.cnet.navy.mil>

## **STUDENT FEEDBACK QUESTIONS**

We value your suggestions, questions, and criticisms on our courses. If you would like to communicate with us regarding this course, we encourage you, if possible, to use e-mail. If you write or fax, please use a copy of the Student Comment form that follows this page.

## **For subject matter questions:**

E-mail: n314.products@cnet.navy.mil

Phone: Comm: (850) 452-1001, Ext. 1826

DSN: 922-1001, Ext. 1826

FAX: (850) 452-1370

(Do not fax answer sheets.)

Address: COMMANDING OFFICER

NETPDTC (CODE 314)

6490 SAUFLEY FIELD ROAD

PENSACOLA FL 32509-5237

## **For enrollment, shipping, grading, or completion letter questions:**

E-mail: fleetservices@cnet.navy.mil

Phone: Toll Free: 877-264-8583

Comm: (850) 452-1511/1181/1859

DSN: 922-1511/1181/1859

FAX: (850) 452-1370

(Do not fax answer sheets.)

Address: COMMANDING OFFICER

NETPDTC (CODE N331)

6490 SAUFLEY FIELD ROAD

PENSACOLA FL 32559-5000

## **NAVAL RESERVE RETIREMENT CREDIT**

If you are a member of the Naval Reserve, you will receive retirement points if you are authorized to receive them under current directives governing retirement of Naval Reserve personnel. For Naval Reserve retirement, this course is evaluated at 12 points. (Refer to *Administrative Procedures for Naval Reservists on Inactive Duty*, BUPERSINST 1001.39, for more information about retirement points.)

## **COURSE OBJECTIVES**

In completing this nonresident training course, you will demonstrate a knowledge of the subject matter by correctly answering questions on the following subjects: Basic Automotive Electricity; Automotive Electrical Circuits and Wiring; Hydraulic and Pneumatic Systems; Automotive Clutches, Transmissions, and Transaxles; Drive Lines, Differentials, Drive Axles, and Power Train Accessories; Construction Equipment Power Trains; Brakes; and Automotive Chassis and Body.



## Student Comments

**Course Title:** Construction Mechanic Basic, Volume 2

**NAVEDTRA:** 14273 **Date:** \_\_\_\_\_

**We need some information about you:**

Rate/Rank and Name: \_\_\_\_\_ SSN: \_\_\_\_\_ Command/Unit \_\_\_\_\_

Street Address: \_\_\_\_\_ City: \_\_\_\_\_ State/FPO: \_\_\_\_\_ Zip \_\_\_\_\_

**Your comments, suggestions, etc.:**

**Privacy Act Statement:** Under authority of Title 5, USC 301, information regarding your military status is requested in processing your comments and in preparing a reply. This information will not be divulged without written authorization to anyone other than those within DOD for official use in determining performance.

NETPDTC 1550/41 (Rev 4-00)



# CHAPTER 1

## BASIC AUTOMOTIVE ELECTRICITY

### INTRODUCTION

**Learning Objective:** Describe the basic principles of electrical and magnetic theory. Identify the materials, the devices, and the different types of electrical circuits. Determine electrical measurements using Ohm's law.

The basic principles of automotive electricity are the essential knowledge required by the mechanic to understand the operation of all-automotive electrical systems and components. Unless you have a clear understanding of these fundamental principles, you will find it difficult to service the various electrical components and systems encountered in the Naval Construction Force (NCF). This understanding will enable you to make sound decisions in the troubleshooting process of all electrical systems.

### BASIC PRINCIPLES OF ELECTRICITY

**Learning Objective:** State the basic principles of electricity, the theory of electricity, and the composition of electricity and matter.

All activity that takes place in any type of electrical circuit depends on the behavior of tiny electrical charges, called electrons. To understand the behavior of electrons, we must investigate the composition of matter. The electron is one of the basic electrical components of all matter.

### COMPOSITION OF MATTER

All matter, regardless of state (solids, liquids, and gases), is made up of tiny particles, known as atoms. Atoms combine in small groups of two or more to form molecules; however, when atoms are divided, smaller particles are created. These particles have positive or negative electrical charges.

There are over 100 different basic materials in the universe. These basic materials are called elements. Iron is one element; copper, aluminum, oxygen, hydrogen, and mercury are examples of elements. The basic particles that make up all the elements, and thus the entire universe, are called protons, electrons, and neutrons. A proton is the basic particle having a single positive charge; therefore, a group of protons produces a positive electrical charge. An electron is the basic particle having a single negative charge; therefore, a group of electrons produces a negative electrical charge. A neutron is the basic particle having no charge; therefore, a group of neutrons would have no charge.

The construction of atoms of the various elements can be examined starting with the simplest of all—hydrogen. The atom of hydrogen consists of one proton, around which is circling one electron (fig. 1-1). There is an attraction between the two particles, because negative and positive electrical charges always attract each other. Opposing the attraction between the two particles, and thus preventing the

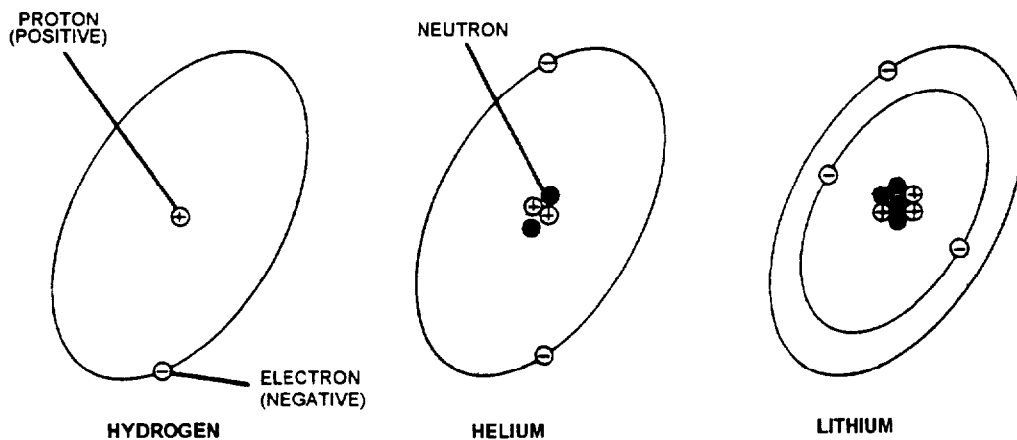

CMB20001

Figure 1-1.—Composition of matter.

electron from moving into the proton, is the centrifugal force on the electron caused by its circular path around the proton. This same sort of balance is produced if a ball tied to string was whirled in a circle in the air. The centrifugal force exerted tries to move the ball out of its circular path and is balanced by the string (the attractive force). If the string should break, the centrifugal force would cause the ball to fly away. Actually, this is what happens at times with atoms. The attractive force between the electron and proton sometimes is not great enough to hold the electron in its circular path and the electron breaks away.

In an atom, unlike electrical charges attract and like electrical charges repel each other. Electrons repel electrons and protons repel protons, except when neutrons are present. Though neutrons have no electrical charge, they do have the ability to cancel out the repelling forces between protons in an atomic nucleus and thus hold the nucleus together.

### COMPOSITION OF ELECTRICITY

When there are more than two electrons in an atom, they move about the nucleus in different orbits (fig. 1-2) which are referred to as shells. The innermost shells of the atom contain electrons that are not easily freed and are referred to as bound electrons. The outermost shell will contain what is referred to as free electrons. These free electrons differ from bound

electrons in that they can be moved readily from their orbit.

If a point that has an excess of electrons (negative) is connected to a point that has a shortage of electrons (positive), a flow of electrons (electrical current) will flow through the connector (conductor) until an equal amount of electrical charge exists between the two points.

### ELECTRON THEORY OF ELECTRICITY

A charge of electricity is formed when numerous electrons break free of their atoms and gather in one area. When the electrons begin to move in one direction (as along a wire, for example), the effect is a flow of electricity or an electric current. Actually, electric generators and batteries could be called electron pumps, because they remove electrons from one part of an electric circuit and concentrate them in another part of the circuit. For example, a generator takes electrons away from the positive terminal and concentrates them at the negative terminal. Because the electrons repel each other (like electrical charges repel), the electrons push out through the circuit and flow to the positive terminal (unlike electrical charges attract). Thus we can see that an electric current is actually a flow of electrons from a negative terminal to a positive terminal.

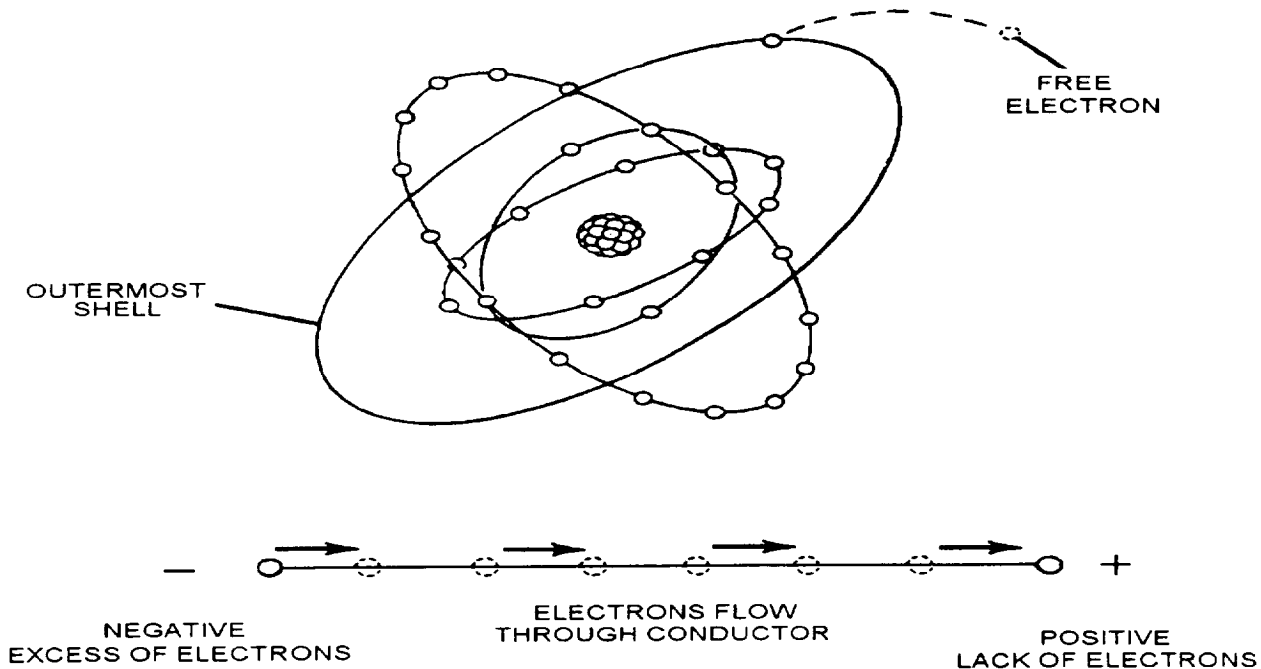

CMB20002

Figure 1-2.—Composition of electricity.

## REVIEW 1 QUESTIONS

- Q1. *How many basic materials are in the universe?*
- Q2. *What three basic particles make up all elements?*
- Q3. *Electrons that have like charges perform what action?*
- Q4. *Scientists discovered that electron flow in an automotive electrical circuit flow in what manner?*

## ELECTRIC CURRENT

**Learning Objective:** Explain the elements involved in electrical current flow and describe the material and devices in use.

It has been proved that electrons (negative charges) move through a conductor in response to an electric field. "Electric current" is defined as the directed flow of electrons and the direction of electron movement is from a region of negative potential to a region of positive potential. Therefore, electric current can be said to flow from negative to positive.

## CONDUCTORS AND INSULATOR

Any material that will allow an electrical current to flow through it is an electrical conductor. Any material that blocks electrical current flow is an electrical insulator. Conductors are used in automotive equipment to carry electric current to all of the electrical equipment. Insulators also are necessary to

keep the electric current from taking a shorter route instead of going to the intended component. The electrical properties of a substance depend mainly on the number of electrons in the outermost shell of each atom. The maximum number of electrons in an outer shell is eight. When there are less than four electrons in the outer shell of an atom, these electrons will tend to be free. This condition allows the free motion of electrons, making the substance a conductor (fig. 1-3).

Electrical energy is transferred through conductors by means of the movement of free electrons that migrate from atom to atom within the conductor. Each electron moves a short distance to the neighboring atom where it replaces one or more electrons by forcing them out of their orbits. The replaced electrons repeat this process in nearby atoms until the movement is transmitted throughout the entire length of the conductor, thus creating a current flow. Copper is an example of a good conductor because it only has one free electron. This electron is not held very strongly in its orbit and can break away from the nucleus very easily. Silver is a better conductor of electricity but it is too expensive to be used in any great quantity. Because of this, copper is the conductor used most widely in automotive applications.

Whenever there are more than four electrons in the outer orbits of the atoms of a substance, these electrons will tend to be bound, causing restriction of free electron movement, making it an insulator (fig. 1-3). Common insulating substances in automotive applications are rubber, plastic, and fiberboard.

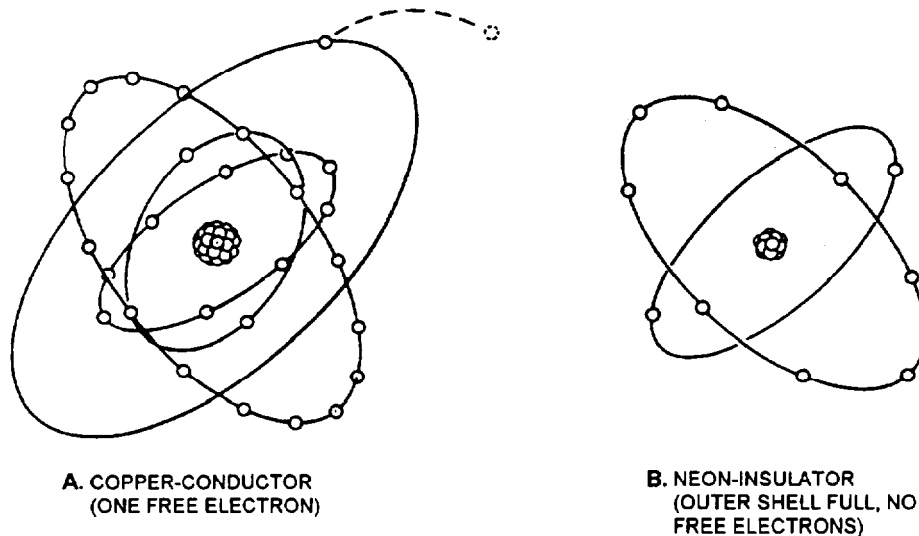

CMB20003

Figure 1-3.—Conductors and insulators.

## SEMICONDUCTORS

A semiconductor is an electrical device that acts as a conductor under certain conditions and as a nonconductor under other conditions. The most popular of all semiconductors is silicon. In its pure state, silicon is neither a good conductor nor insulator. But by processing silicon in the following ways, its conductive or insulative properties can be adjusted to suit just about any need. When a number of silicon atoms are jammed together in crystalline (glasslike) form, they form a covalent (sharing) bond. Therefore, the electrons in the outer ring of one silicon atom join with the outer ring of other silicon atoms, resulting in a sharing of outer ring electrons between all of the atoms. It can be seen in figure 1-4 that covalent sharing

gives each atom eight electrons in its outer orbit, making the orbit complete. This makes the material an insulator because it contains more than four electrons in its outer orbit. When certain materials, such as phosphorus, are added to the silicon crystal in highly controlled amounts, the resultant mixture becomes a conductor (fig. 1-5). This is because phosphorus, which has five electrons in forming a covalent bond with silicon (which has four electrons in its outer shell), will yield one free electron per molecule, thus making the material an electrical conductor. The process of adding impurities to a semiconductor is called doping. Any semiconductor material that is doped to yield free electrons is called N-type material.

When boron, which has three electrons in its outer ring, is used to dope the silicon crystal, the resultant

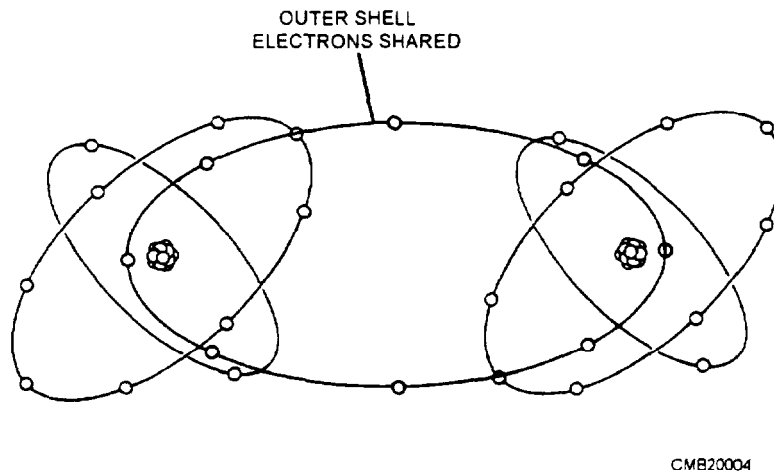

Figure 1-4.—Covalent bonding of silicon.

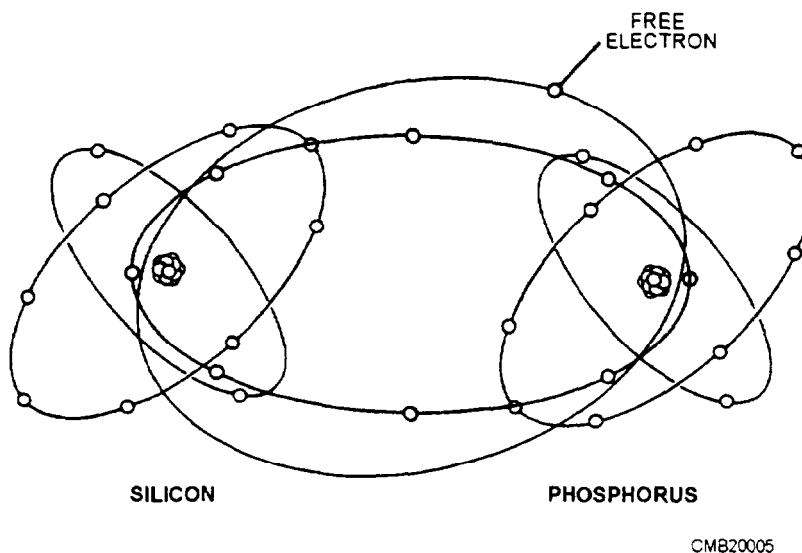

Figure 1-5.—Phosphorus-doped silicon.



covalent bonding yields seven electrons in the outer shell. This leaves an opening for another electron and is shown in figure 1-6. This space is called a hole and can be considered a positive charge, just as the extra electrons that exist in N-type semiconductor material are considered a negative charge. Materials that have holes in their outermost electron shells are called positive or P-type materials. To understand the behavior of P-type semiconductors, it is necessary to look upon the hole as a positive current carrier, just as the free electron in N-type semiconductors are considered negative current carriers. Just as electrons move through N-type semiconductors, holes move from atom to atom in P-type semiconductors. Movement of holes through P-type semiconductors, however, is from the positive terminal to the negative terminal. For this reason, any circuit analysis of solid-state circuitry is done on the basis of positive to negative (conventional) current flow.

When a source voltage, such as a battery, is connected to N-type material, an electric current will flow through it, as shown in figure 1-7. The current flow in the N-type semiconductor consists of the movement of free electrons, the same as the current flow through a natural conductor, such as copper. When a current source of sufficient voltage is connected across a P-type material, an electric current will also flow through it, but any current flow in a P-type semiconductor is looked upon as the movement of positively charged holes. The holes appear to move toward the negative terminal, as the electrons enter the material at the negative terminal, fill the holes, and then move from hole to hole toward the positive terminal. As is the case with the N-type semiconductors, the movement of electrons through P-type semiconductors toward the positive terminal is motivated by the natural attraction of unlike charges.

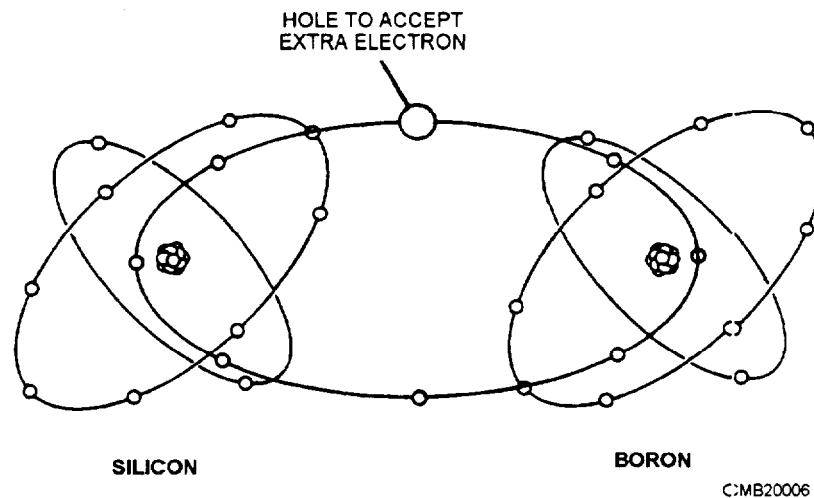

Figure 1-6.—Boron-doped silicone.

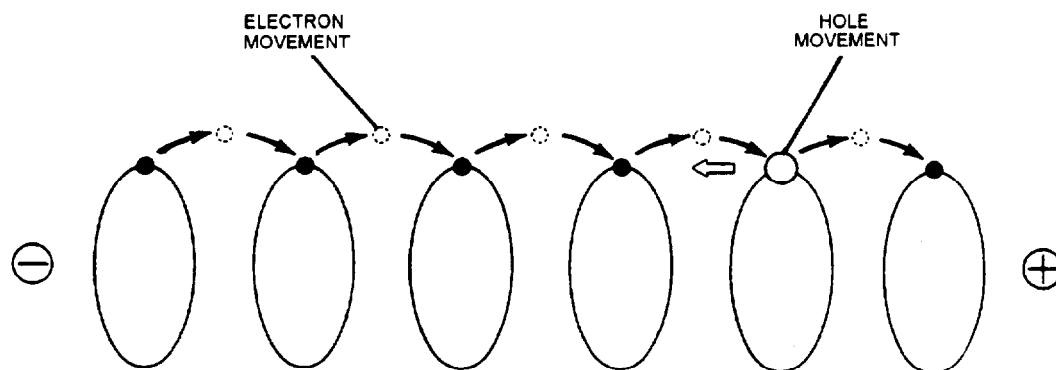

Figure 1-7.—Hole movement theory.

## Diodes

A diode (fig. 1-8) is a device that will allow current to pass through itself in only one direction. A diode can be thought of as an electrical check valve. Diodes are constructed by joining N-type material and P-type material together. The negative electrical terminal is located on the N-type material and the positive terminal is located on the P-type material.

When a diode is placed in a circuit, the N-material is connected to the negative side of the circuit and the positive side of the circuit is connected to the P-material. In this configuration, which is known as forward bias, the diode is a good conductor. This is because the positively charged holes in the P-type material move toward the junction and fill these holes using them to move across the P-material. If the connections to the diodes are reversed, current flow will be blocked. This design is known as reverse bias. When the diode is connected backwards, the positively charged holes are attracted away from the junction to the negative terminal and the free electrons in the N-material are attracted away from the junction to the positive terminal. Without the presence of holes at the junction, the electrons are not able to cross it.

### Zener Diodes

A zener diode (fig. 1-9) is a special type of diode that conducts current in the reverse direction as long as the voltage is above a predetermined value that is built into the device during manufacturing. For instance, a certain zener diode may not conduct current if the reverse bias voltage is below 6 volts. As the voltage

increases to 6 volts or more, the diode suddenly will begin to conduct reverse bias current. This device is used in control circuits, such as voltage regulators.

## Transistors

A transistor (fig. 1-10) is an electrical device that is used in circuits to control the flow of current. It operates by either allowing current to flow or not allowing it to flow. Transistors operate electronically and have no moving parts to perform their function. This design allows for a longer operating life of the component. The major automotive applications of transistors are for electronic ignition systems and voltage regulators.

The PNP transistor (fig. 1-11) is the most common design in automotive applications. It is manufactured by sandwiching an N-type semiconductor element between two P-type semiconductor elements. A positive charge is applied to one of the P-type elements. This element is called the emitter. The other P-type element connects to the electrical component. This element is called the collector. The third element, which is in the middle, is made of N-type material and is called the base. The application of low current negative charge to the base will allow a heavy current to flow between the emitter and the collector. Whenever the current to the base is switched off, the current flow from the emitter to the collector is interrupted also.

The NPN transistor (fig. 1-11) is similar to the PNP transistor. The difference is that it is used in the negative side of the circuit. As the term NPN implies,

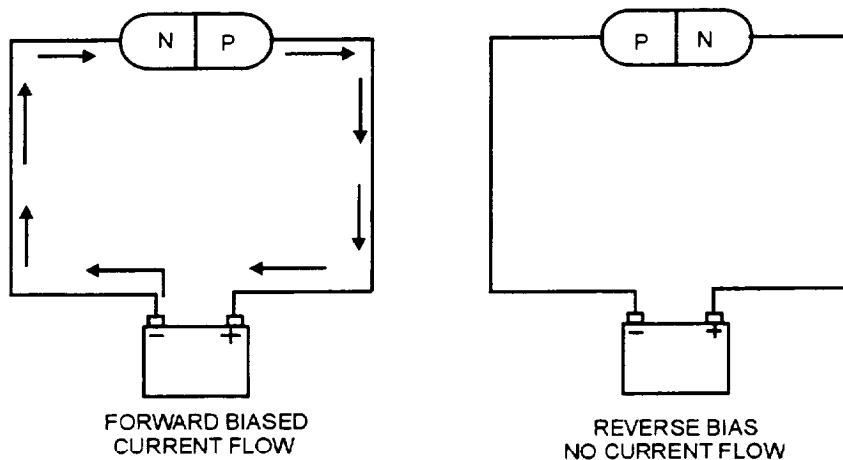

CMB20008

Figure 1-8.—Diode operation.

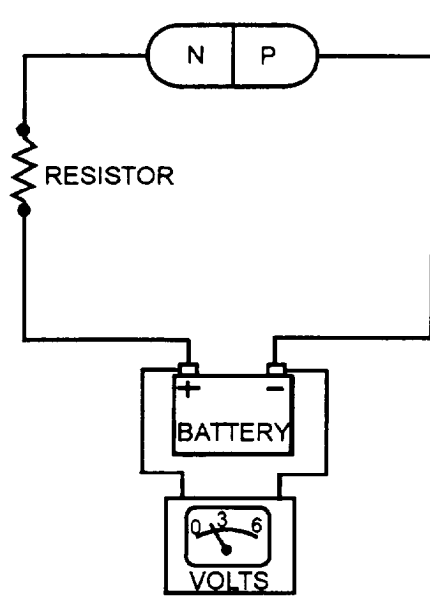
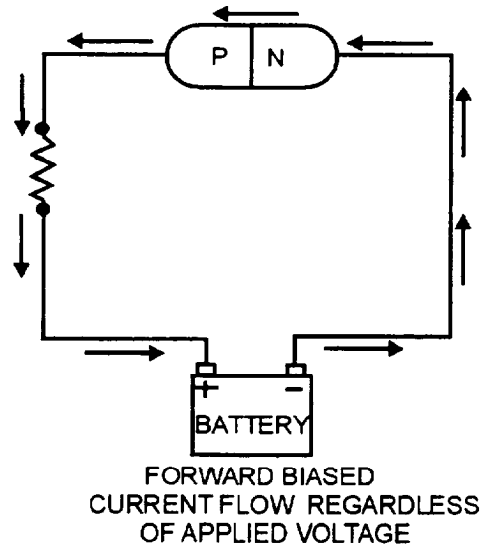

REVERSE BIAS  
NO CURRENT FLOW  
BELOW 6 VOLTS

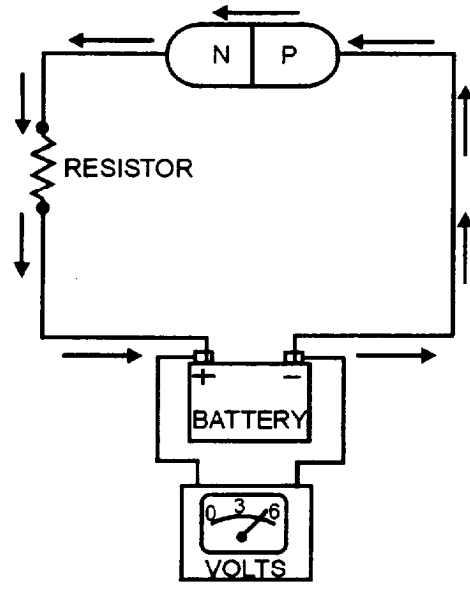

REVERSE BIAS  
CURRENT FLOW BEGINS AS  
APPLIED VOLTAGE REACHES 6

CMB20009

Figure 1-9.—Zener diode operation.

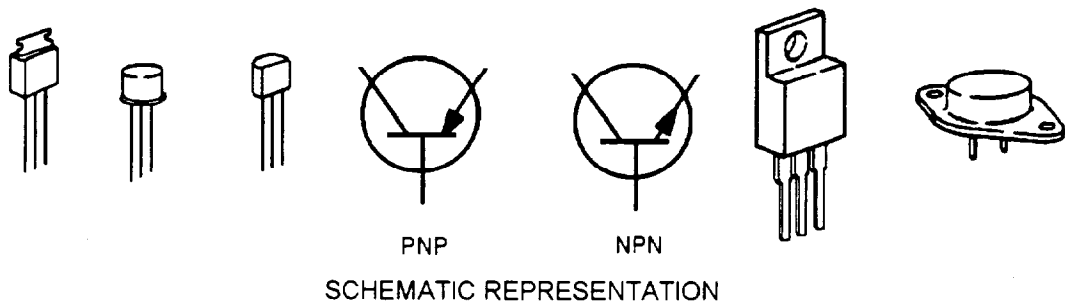

CMB20010

Figure 1-10.—Transistor configurations.

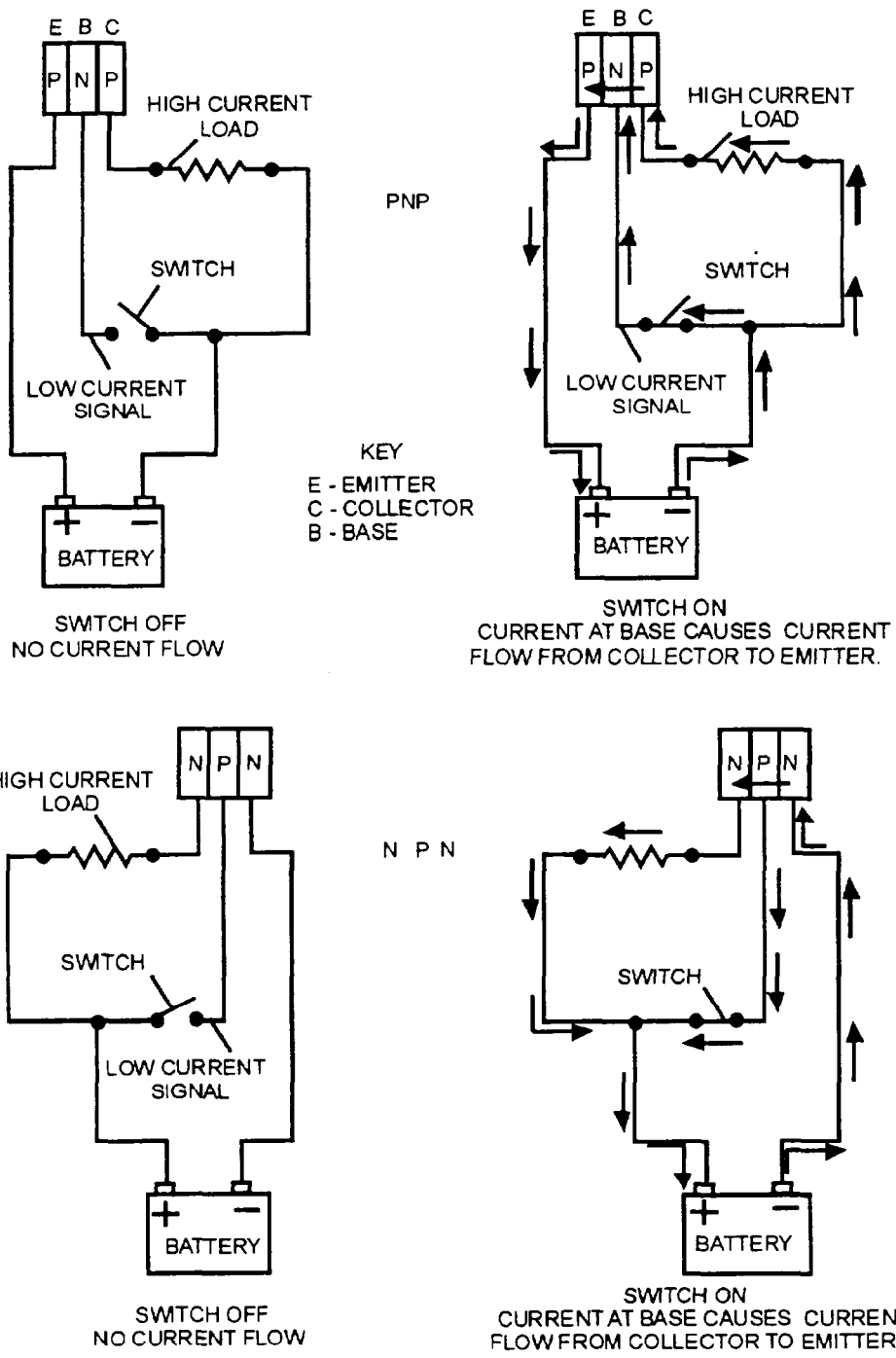

CMB20011

Figure 1-11.—Transistor operation.

the makeup of this transistor is two elements of N-type material (collector and emitter) with an element of P-type material (base) sandwiched in between. The NPN transistor will allow a high current negative charge to flow from the collector to the emitter whenever a relatively low current positive charge is applied to the base.

**REVIEW 2 QUESTIONS**

- Q1. What material allows electric current to flow?
- Q2. Name two electrical components that use semiconductors?
- Q3. What is the basic difference in operation between a diode and a transistor?

## ELECTRIC MEASUREMENTS

Learning Objective: Determine voltage, amperage, and resistance. Explain Ohm's law and describe the types of electrical circuits used in vehicles.

Electricity is measured in two ways—by the amount of current (number of electrons) flowing and by the push, or pressure, that causes current to flow. The push, or pressure, is caused by actions of the electrons. They repel each other. When electrons are concentrated in one place, their negative charges push against each other. If a path is provided for the electrons, they will flow away from the area where they are concentrated.

The pressure to make them move is called voltage. If there are many electrons concentrated in one spot, we say that there is high voltage. With high voltage, many electrons will flow, provided there is a path or conductor through which they can flow. The more electrons that flow, the greater the electric current. Electric current is measured in amperes. Resistance is the movement of electrons through a substance. Resistance is a fact of life in electric circuits. We want resistance in some circuits so that too much current (too many electrons) will not flow. In other circuits, we want as little resistance as possible so that high current can flow.

There is a definite relation between current (electron flow), voltage (current pressure), and resistance. As the electric pressure goes up, more electrons flow. Increasing the voltage increases the amperes of current. However, increasing the resistance decreases the amount of current that flows. These relationships can be summed up in a statement known as Ohm's law.

### VOLTAGE

Electrons are caused to flow by a difference in electron balance in a circuit; that is, when there are more electrons in one part of a circuit than in the other, the electrons move from the area where they are concentrated to the area they are lacking. This difference in electron concentration is called potential difference, or voltage. The higher the voltage goes, the greater the electron imbalance becomes. The greater this electron imbalance, the harder the push on the electrons (more electrons repelling each other) and the greater the current of electrons in the circuit. When there are many electrons concentrated at the negative terminal of a generator (with a corresponding lack of

electrons at the positive terminal), there is a much stronger repelling force on the electrons; consequently, many more electrons are moving in the wire. This is exactly the same as saying that the higher the voltage, the more the electric current will flow in a circuit, all other things, such as resistance, being equal.

### AMPERAGE

Current flow, or electron flow, is measured in amperes. While we normally consider that one ampere is a rather small current of electricity (approximately what a 100-watt light bulb would draw), it is actually a tremendous flow of electrons. More than 6 billion electrons a second are required to make up one ampere.

### RESISTANCE

A copper wire conducts electricity with relative ease; however, it offers resistance to electron flow. This resistance is caused by the energy required to free the outer shell of electrons and the collision between the atoms of the conductor and the free electrons. It takes **electromotive force** (emf) or voltage to overcome the resistance met by the flowing electrons. The basic unit of resistance is the **ohm**. The resistance of a conductor varies with its length, diameter, composition, and temperature. A long wire offers more resistance than a short wire of the same diameter; this is due to the electrons having farther to travel. Some materials can lose electrons more readily than others. Copper loses electrons easily, so there are always many free electrons in a copper wire. Other materials, such as iron, do not lose their electrons as easily, so there are fewer free electrons in an iron wire. However, fewer electrons can push through an iron wire; that is, the iron wire has more resistance than the copper wire. A wire with a small diameter offers more resistance than a wire with a large diameter. In the small diameter wire, there are fewer free electrons, and thus fewer electrons can push through. Most metals show an increase in resistance with an increase in temperature, while most nonmetals show a decrease in resistance with an increase in temperature.

### OHM'S LAW

Ohm's law is used to figure out the current (I), the voltage (E), and the resistance (R) in a circuit. This law states that voltage is equal to amperage times ohms. Or, it can be stated as the mathematical formula:  $E = I \times R$ . For the purpose of solving problems, the Ohm's law formula can be expressed in three ways:

1. To find voltage:  $E = IR$

2. To find amperage:  $I = E/R$
3. To find ohms:  $R = E/I$

The Ohm's law formula is a useful one to remember because it helps in understanding the many things that occur in an electric circuit. For example, if the voltage remains constant, the current flow goes down if the resistance goes up. This can be better explained by using a truck lighting circuit that is going bad. Suppose the wiring circuit between the battery and the lights has deteriorated due to connections becoming poor, strands in the wire breaking, and switch contacts becoming dirty. All of these conditions reduce the electron path or, in other words, increase resistance. This increased resistance decreases the current flow with the battery voltage constant (for example, 12 volts). If the resistance of the circuit when new was 6 ohms, then 2 amperes will flow. To answer the equation, 12 (volts) must equal 12 (amperes times ohms). But if the resistance goes up to 8 ohms, only 1.5 amperes can flow. The increased resistance cuts down the current flow and, consequently, the amount of light.

If the resistance stays the same but the voltage increases, the amperage also increases. This is a condition that might occur if a generator voltage regulator became defective. In such a case, there would

be nothing to hold the generator voltage within limits, and the voltage might increase excessively. This would force excessive amounts of current through various circuits and cause serious damage. If too much current went through the light bulb filaments, for example, the filaments would overheat and burn out. Also, other electrical devices probably would be damaged. However, if the voltage is reduced, the amount of current flowing in a circuit will also be reduced if the resistance stays the same.

For example with a run-down battery, battery voltage will drop excessively with a heavy discharge. When you are trying to start an engine with a run-down battery, the voltage will drop very low. This voltage is so low that it cannot push enough current through the starter for effective starting of the engine.

## CIRCUIT CONFIGURATIONS

**Automotive circuits** (fig. 1-12). The body and chassis of an automobile are made of steel. This feature is used to eliminate one of the wires from all of the automobile circuits. By attaching one of the battery terminals to the body and chassis, you can connect any electrical component by hooking up one side, by wire, to the car battery and the other side to the body. This design of connecting one side of the battery to the

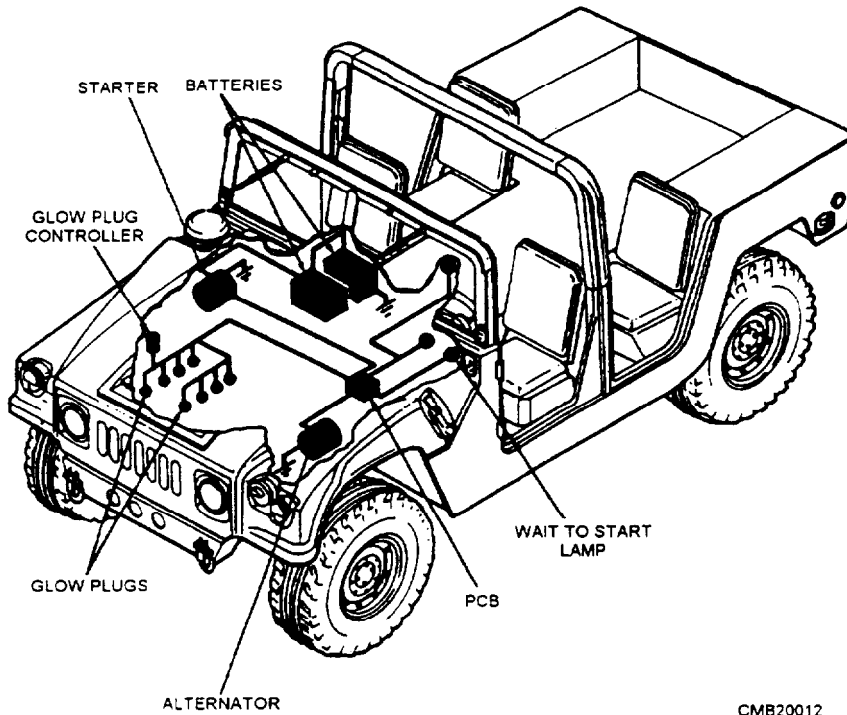

Figure 1-12.—Typical automotive circuit.

automobile body is called grounding. The majority of equipment you will encounter in the NCF will have an electrical system with a negative ground. Vehicles with positive ground are very uncommon, but it is always good practice to note what type of grounding system is used on the equipment you are working on.

**Series circuits** (fig. 1-13, view A). A series circuit consists of two or more electrical components connected in such a manner that current will flow through all the components. Important characteristics of a series circuit are as follows:

- Any break in the circuit (such as a burned-out light bulb) will render the entire circuit inoperative.
- Current (amperage) will be constant throughout the circuit.
- Total resistance of the circuit is equal to the sum of each individual resistance.
- Total voltage of the circuit is equal to the sum of the individual voltage drops across each component.

**Parallel circuits** (fig. 1-13, view B). A parallel circuit consists of two or more electrically operated components connected by parallel wires. In a parallel circuit, the current divides, part of it flowing into one component and part into the others. Practically the same voltage is applied to each component, and each component can be turned on or off independently of the

others. Important characteristics of parallel circuits are as follows:

- The total resistance of the circuit will always be less than the resistance of any individual component.
- The disconnection or burning out of any individual component in the circuit will not affect the operation of the others.
- The current will divide itself among the circuit branches according to the resistance of the individual devices. The sum of the individual amperages will be equal to the total circuit current.
- The voltage will be constant throughout the circuit when measured across the individual branches.

**Series-parallel circuits** (fig. 1-13, view C). The series-parallel circuit is a combination of the two configurations. There must be at least three resistance units to have a series-parallel circuit. Important characteristics of series-parallel circuits are as follows:

- The total circuit voltage will be equal to the sum of the total parallel circuit voltage drop plus the voltage drop of the individual series circuit component.
- The total circuit resistance will be equal to the sum of the total parallel circuit resistance plus the individual resistance of the series circuit components.

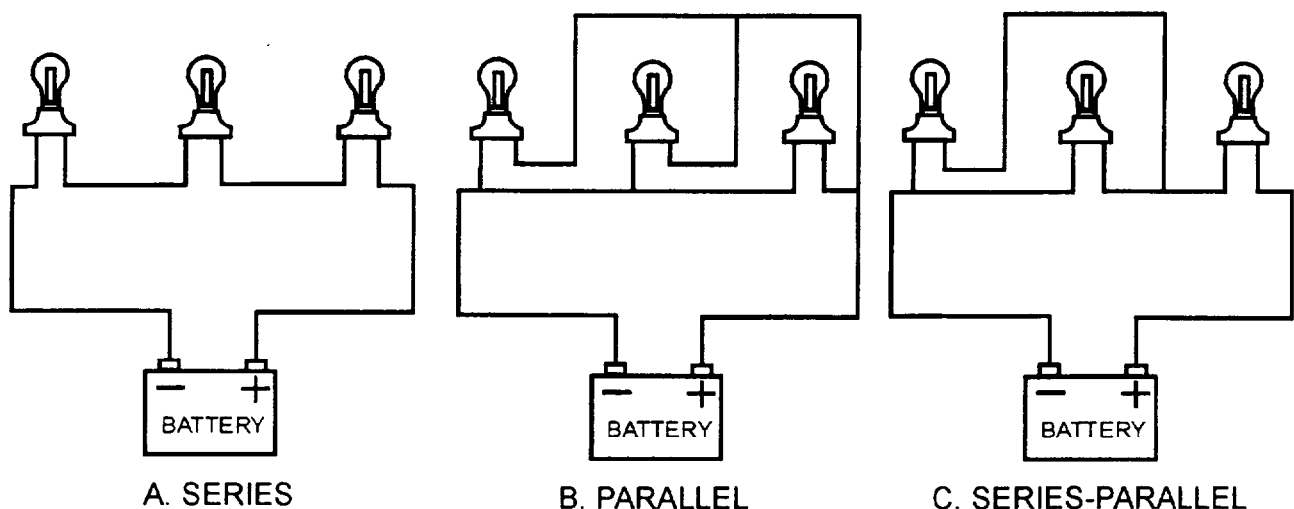

CMB20013

Figure 1-13.—Circuit configurations.

- Current flow through the total parallel circuit will be equal to the current flow through any individual series circuit component.
- The disconnection or the burning out of the series components will completely disable the entire circuit, whereas a failure of any of the parallel circuit components will leave the balance of the circuit still functioning.

### CIRCUIT FAILURES

**Open circuit** (fig. 1-14, view A). An open circuit is a break or interruption in the circuit, such as a wire that has come loose or a slipped connection that is not making contact. But the expression of an open circuit is not only used when wire connections are actually separated as in a switch but also when the resistance in the wiring circuit is so that no current can flow between the battery and the unit it operates. A good example of such a condition is rust and corrosion that forms and accumulates at a battery cable or terminal.

**Ground circuit.** A ground circuit occurs when any part of the wiring circuit is touching the vehicle frame inadvertently. A ground involves accidental or unintentional contact between copper and the iron frame.

**Short circuit** (fig. 1-14, view B). A short circuit occurs when copper touches copper, such as when wiring insulation between two wires fails and the wiring makes contact.

### REVIEW 3 QUESTIONS

- Q1. Voltage is known by what term?
- Q2. What are the three basic types of electrical circuits?
- Q3. What type of circuit failure occurs when copper touches copper?

### MAGNETISM

**Learning Objective:** Describe the theory of magnetism and the principles of electromagnetism and electromagnetic induction.

*Magnetic field* is described as invisible lines of force which come out of the North Pole and enter the South Pole. For example, if iron filings were sprinkled on a piece of glass on top of a bar magnet, the filings would form themselves in curved lines

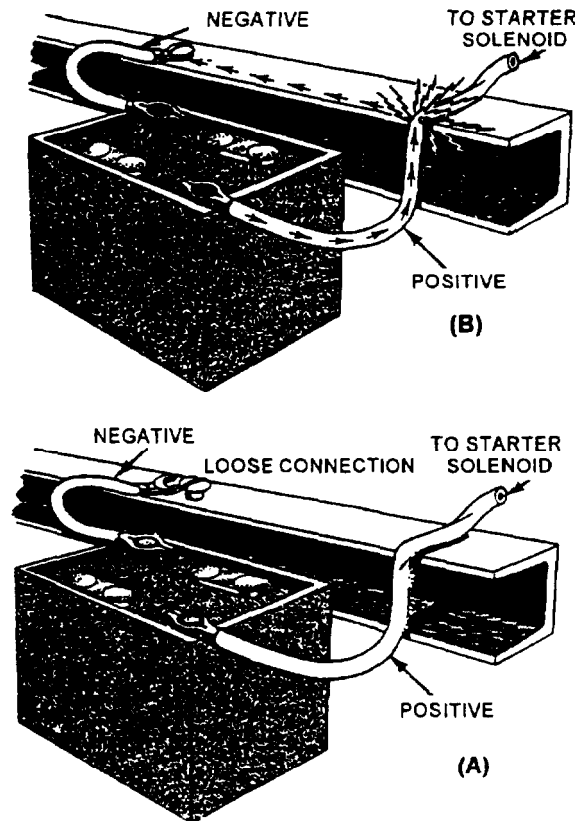

CMB20014

Figure 1-14.—(A) Open circuit; (B) Short circuit.



(fig. 1-15). These curved lines, extend from the two poles of the magnet, follow the magnetic lines of force surrounding the magnet. Lines of force rules are as follows:

- The lines of force (outside the magnet) pass from the North Pole to the South Pole of the magnet.
- The lines of force act somewhat as rubber bands and try to shorten to minimum length.
- The lines of force repel each other along their entire length and try to push each other apart.
- The rubber band characteristic opposes the push-apart characteristic.
- The lines of force never cross each other.
- The magnetic lines of force, taken together, are referred to as the magnetic field of the magnet.

The magnetic fields of a bar and of a horseshoe magnet are shown in figure 1-16. In each, note how the lines of force curve and pass from the North Pole to the South Pole.

Effects between magnetic poles (fig. 1-17). When two UNLIKE magnetic poles are brought together, they attract. But when LIKE magnetic poles are brought together, they repel. These actions can be explained in terms of the rubber band and the push-apart characteristics. When unlike poles are brought close to each other, the magnetic lines of force pass from the North Pole to the South Pole. They try to shorten (like rubber bands) and, therefore, try to pull the two poles together. On the other hand, if like poles are brought close to each other, lines of force going in the same direction are brought near each other. Because these lines of force attempt to push apart, a repelling effect results between the like poles.

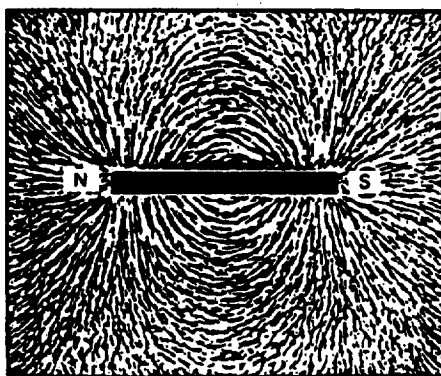

CMB20015

Figure 1-15.—Magnetic lines of force.

## ELECTROMAGNETISM

An electric current (flow of electrons) always creates a magnetic field. In the wire shown in figure 1-18, current flow causes lines of force to circle the wire. It is thought that these lines of force result from the movement of the electrons along the wire. As they move, the electrons send out the lines of force. When many electrons move, there are many lines of force (the magnetic field is strong). Few electrons in motion means a weak magnetic field or few lines of force.

Electron movement as the basis of magnetism in bar and horseshoe magnets can be explained by assuming that the atoms of iron are so lined up in the magnets that the electrons are circling in the same direction and their individual magnetic lines of force add to produce the magnetic field.

The magnetic field is produced by current flowing in a single loop of wire (fig. 1-19). The magnetic lines of force circle the wire, but here they must follow the

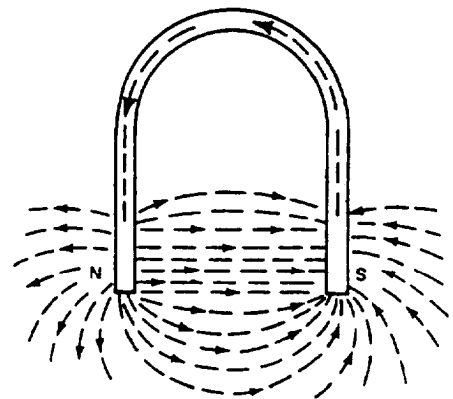
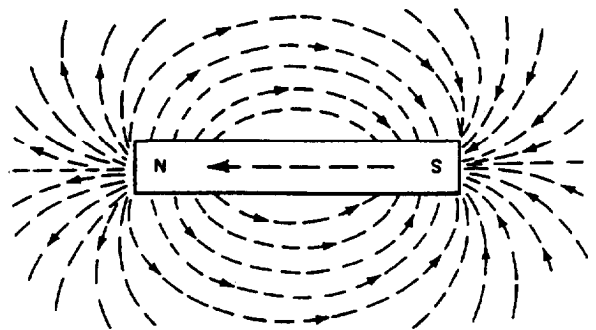

CMB20016

Figure 1-16.—Bar and horseshoe magnet.



CMB20017

Figure 1-17.—Effects between magnetic poles.

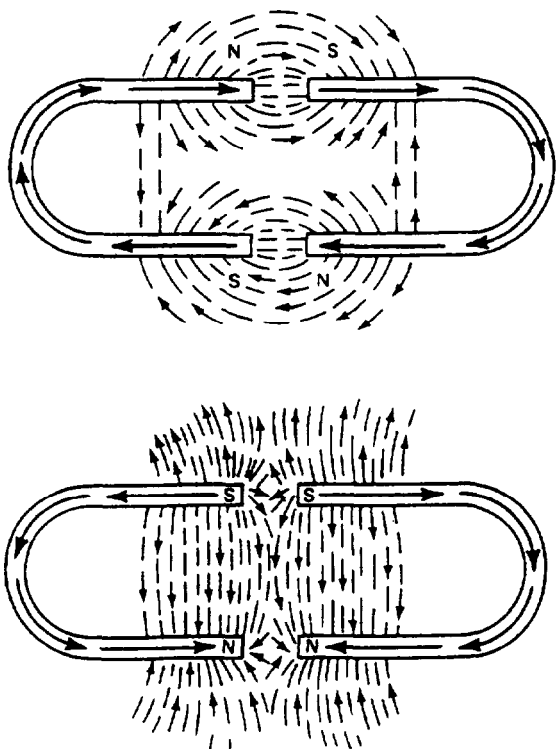

CMB20018

Figure 1-18.—Electromagnetism.

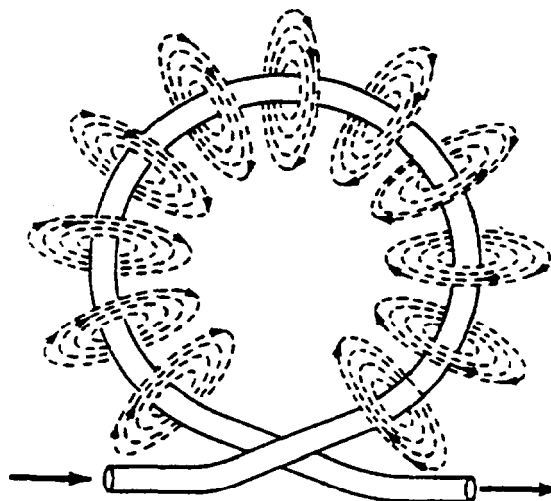

CMB20019

Figure 1-19.—Electromagnetism in a wire loop.

curve of the wire. If two loops are made in the conductor, the lines of force will circle the two loops. In the area between the adjacent loops, the magnetic lines are going in opposite directions. In such a case, because they are of the same strength (from same amount of current traveling in both loops), they cancel each other out. The lines of force, therefore, circle the two loops almost as though they were a single loop. However, the magnetic field will be twice as strong because the lines of force of the two loops combine.

When many loops of wire are formed into a coil, as shown in figure 1-20, the lines of force of all loops combine into a pattern that greatly resembles the magnetic field surrounding a bar magnet. A coil of this

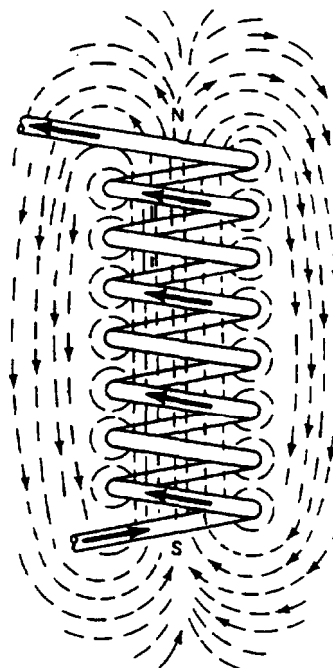

CMB20020

Figure 1-20.—Electromagnetism in a wire coil.

type is known as an electromagnet or a solenoid. Electromagnets can be in many shapes. The field coils of generators and starters, the primary winding in an ignition coil, the coils in electric gauges, even the windings in a starter armature, can be considered to be electromagnets. All of these components produce magnetism by electrical means.

The North Pole of an electromagnet can be determined, if the direction of current flow (from negative to positive) is known, by use of the left-hand rule (fig. 1-21). The left hand is around the coil with the fingers pointing in the direction of current flow. The thumb will point to the North Pole of the electromagnet. This rule is based on current, or electron, flow from negative to positive.

The left-hand rule also can be used to determine the direction that the lines of force circle a wire-carrying current if the direction of current is known. This is done by circling the wire with the left hand with the thumb pointing in the direction of current flow (negative to positive). The fingers will then point in the direction that the magnetic field circles the wire.

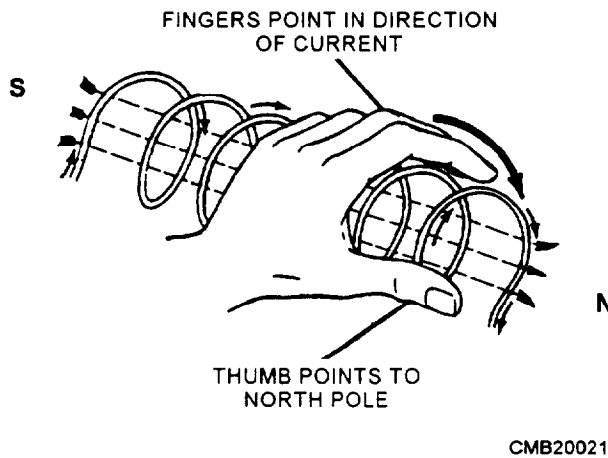

Figure 1-21.—Left-hand rule.

The strength of an electromagnet can be increased greatly by wrapping the loops of wire around an iron core. The iron core passes the lines of force with much greater ease than air. This effect of permitting lines of force to pass through easily is called permeability. Wrought iron is 3,000 times more permeable than air. In other words, it allows 3,000 times as many lines of force to get through. With this great increase in the number of lines of force, the magnetic strength of the electromagnet is greatly increased, even though no more current flows through it. Practically all electromagnets use an iron core of some type.

## ELECTROMAGNETIC INDUCTION

Current can be induced to flow in a conductor if it is moved through a magnetic field. In figure 1-22, the wire is moved downward through the magnetic field between the two magnetic poles. As it moves downward cutting lines of force, current is induced in it. The reason for this is that the line of force resists cutting and tends to wrap around the wire as shown. With lines of force wrapping around the wire, current is induced. The wire movement through the magnetic field produces a magnetic whirl around the wire, which pushes the electrons along the wire.

If the wire is held stationary and the magnetic field is moved, the effect is the same. All that is required is that there be relative movement between the conductor and the magnetic lines of force to produce enough voltage to move the electrons along the conductor.

Moving the magnet can move the magnetic field or, if it is a magnetic field from an electromagnet, starting and stopping the current flow in the electromagnet can move it. Suppose an electromagnet, such as the one shown in figure 1-20, has a wire held close to it. When the electromagnet is connected to a battery, current will start to flow through it. This current, as it starts to flow, builds up a magnetic field.

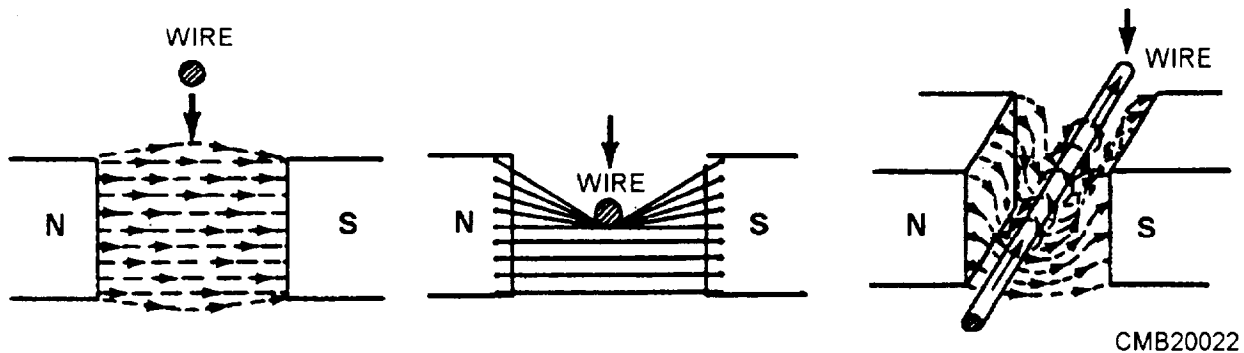

Figure 1-22.—Electromagnetic induction.

A magnetic field forms because of the current flow. This magnetic field might be considered to expand and move out from the electromagnet. As the lines of force move out, the wire will cut them. This wire will therefore have current induced in it. If the electromagnet is disconnected from the battery, these lines of force will disappear and current will stop flowing in the wire.

It can be seen now that current can be induced in a wire by three methods:

1. The wire can be moved through the stationary magnetic field (the principle applied in a dc generator).
2. The wire can be held stationary and the magnet can be moved so the field is carried

past the wire (the principle applied in an ac generator).

3. The wire and electromagnet can both be held stationary and the current turned on and off to cause the magnetic field to build up and collapse so the magnetic field moves one way or the other across the wire (the principle applied in an ignition coil).

#### **REVIEW 4 QUESTIONS**

- Q1. A magnetic field has what type of lines of force?*
- Q2. When like magnetic poles are brought together, what action occurs?*
- Q3. What are two parts of a basic electromagnet?*

### **REVIEW 1 ANSWERS**

- Q1. Over 100*
- Q2. Protons, electrons, and neutrons*
- Q3. Repel each other*
- Q4. From a negative terminal to a positive terminal*

### **REVIEW 2 ANSWERS**

- Q1. Electrical conductor*
- Q2. Diodes and transistors*
- Q3. A diode allows current to pass through but in only one direction; whereas, a transistor allows current to pass through or stops current flow*

### **REVIEW 3 ANSWERS**

- Q1. Potential difference*
- Q2. Series, parallel, and series-parallel*
- Q3. Short circuit*

### **REVIEW 4 ANSWERS**

- Q1. Invisible lines of force*
- Q2. They repel each other*
- Q3. A coil of wire wound over a soft iron core*



## CHAPTER 2

# AUTOMOTIVE ELECTRICAL CIRCUITS AND WIRING

### INTRODUCTION

**Learning Objective:** Identify charging, starting, ignition, and accessory-circuit components, their functions, and maintenance procedures. Identify the basic types of automotive wiring, types of terminals, and wiring diagrams.

The electrical systems on equipment used by the Navy are designed to perform a variety of functions. The automotive electrical system contains five electrical circuits. These circuits are as follows (fig. 2-1):

- Charging circuit

- Starting circuit
- Ignition circuit
- Lighting circuit
- Accessory circuit

Electrical power and control signals must be delivered to electrical devices reliably and safely so electrical system functions are not impaired or converted to hazards. This goal is accomplished through careful circuit design, prudent component selection, and practical equipment location. By carefully studying this chapter and the preceding

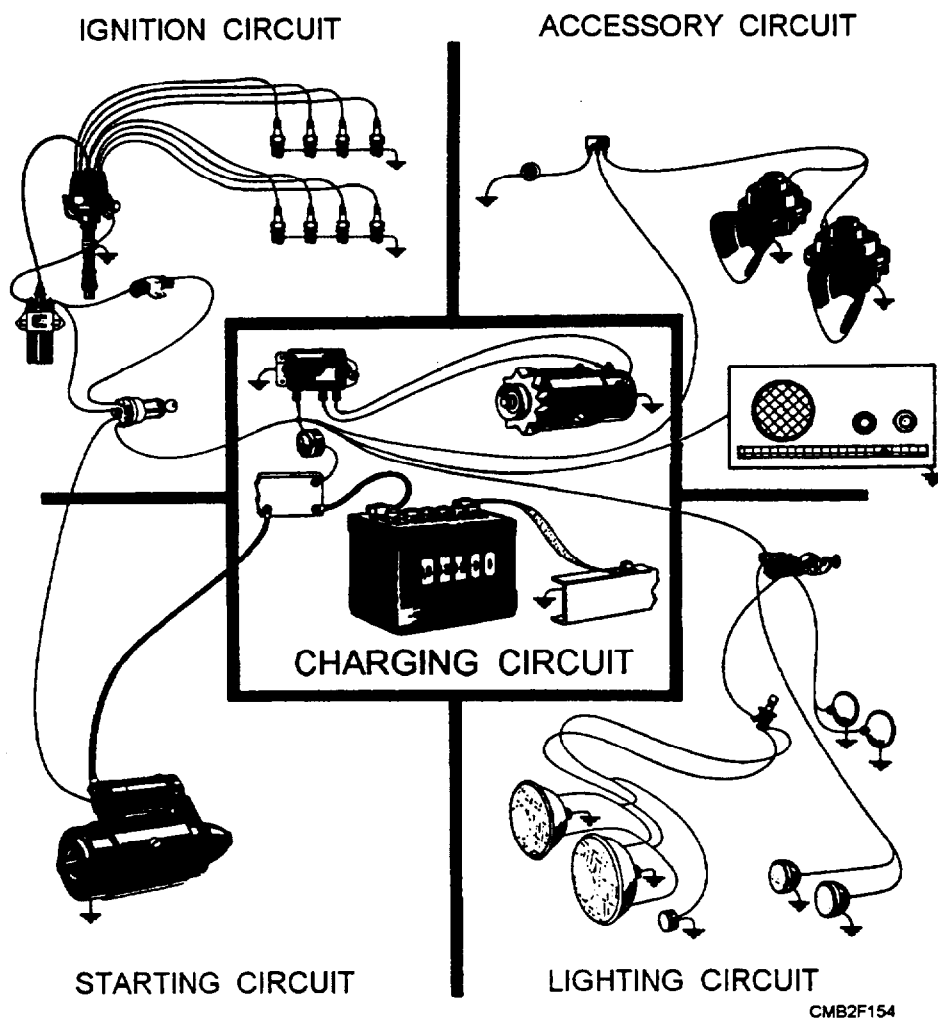

CMB2F154

Figure 2-1.—Electrical circuits.

chapter, you will understand how these circuits work and the adjustments and repairs required to maintain the electrical systems in peak condition.

## CHARGING CIRCUIT

**Learning Objective:** Identify charging-circuit components, their functions, and maintenance procedures.

The charging system performs several functions, which are as follows:

- It recharges the battery after engine cranking or after the use of electrical accessories with the engine turned off.
- It supplies all the electricity for the vehicle when the engine is running.
- It must change output to meet different electrical loads.
- It provides a voltage output that is slightly higher than battery voltage.

A typical charging circuit consists of the following:

- **BATTERY**—provides current to energize or excite the alternator and assists in stabilizing initial alternator output.

- **ALTERNATOR or GENERATOR**—uses mechanical (engine) power to produce electricity.
- **ALTERNATOR BELT**—links the engine crankshaft pulley with alternator/generator pulley to drive the alternator/generator.
- **VOLTAGE REGULATOR**—ammeter, voltmeter, or warning light to inform the operator of charging system condition.

## STORAGE BATTERY

The storage battery is the heart of the charging circuit (fig. 2-2). It is an electrochemical device for producing and storing electricity. A vehicle battery has several important functions, which are as follows:

- It must operate the starting motor, ignition system, electronic fuel injection system, and other electrical devices for the engine during engine cranking and starting.
- It must supply ALL of the electrical power for the vehicle when the engine is not running.
- It must help the charging system provide electricity when current demands are above the output limit of the charging system.

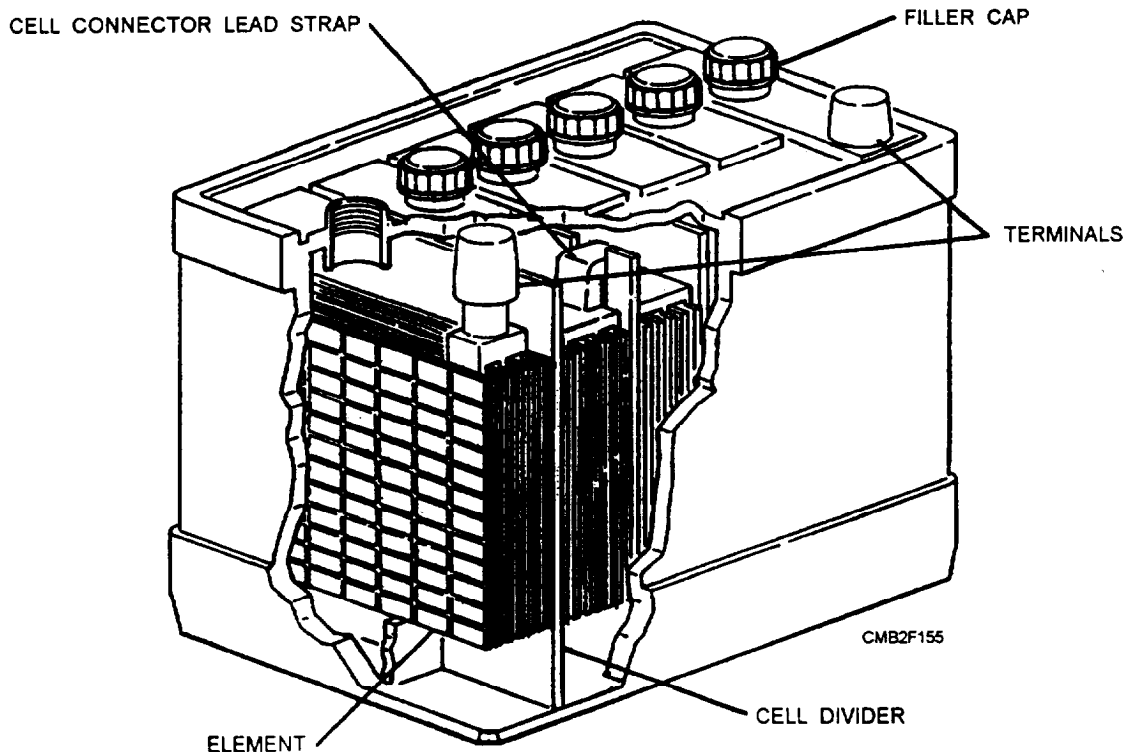

Figure 2-2.—Gross section of a typical storage battery.



- It must act as a capacitor (voltage stabilizer) that smoothes current flow through the electrical system.
- It must store energy (electricity) for extended periods.

The type of battery used in automotive, construction, and weight-handling equipment is a lead-acid cell-type battery. This type of battery produces direct current (dc) electricity that flows in only one direction. When the battery is discharging (current flowing out of the battery), it changes chemical energy into electrical energy, thereby, releasing stored energy. During charging (current flowing into the battery from the charging system), electrical energy is converted into chemical energy. The battery can then store energy until the vehicle requires it.

### Battery Construction

The lead-acid cell-type storage battery is built to withstand severe vibration, cold weather, engine heat, corrosive chemicals, high current discharge, and prolonged periods without use. To test and service batteries properly, you must understand battery construction. The construction of a basic lead-acid cell-type battery is as follows:

- Battery element
- Battery case, cover, and caps
- Battery terminals
- Electrolyte

**BATTERY ELEMENT.**—The battery element is made up of negative plates, positive plates, separators, and straps (fig. 2-3). The element fits into a cell compartment in the battery case. Most automotive batteries have six elements.

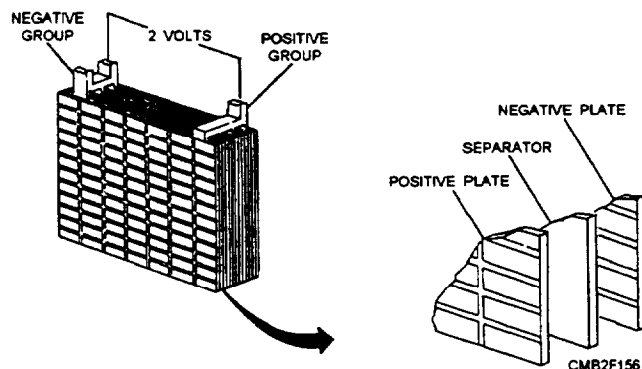

Figure 2-3.—Battery element.

Each cell compartment contains two kinds of chemically active lead plates, known as positive and negative plates. The battery plates are made of GRID (stiff mesh framework) coated with porous lead. These plates are insulated from each other by suitable separators and are submerged in a sulfuric acid solution (electrolyte).

Charged negative plates contain spongy (porous) lead (Pb) which is gray in color. Charged positive plates contain lead peroxide (PbO<sub>2</sub>) which has a chocolate brown color. These substances are known as the active materials of the plates. Calcium or antimony is normally added to the lead to increase battery performance and to decrease gassing (acid fumes formed during chemical reaction). Since the lead on the plates is porous like a sponge, the battery acid easily penetrates into the material. This aids the chemical reaction and the production of electricity.

Lead battery straps or connectors run along the upper portion of the case to connect the plates. The battery terminals (post or side terminals) are constructed as part of one end of each strap.

To prevent the plates from touching each other and causing a short circuit, sheets of insulating material (microporous rubber, fibrous glass, or plastic-impregnated material), called separators, are inserted between the plates. These separators are thin and porous so the electrolyte will flow easily between the plates. The side of the separator that is placed against the positive plate is grooved so the gas that forms during charging will rise to the surface more readily. These grooves also provide room for any material that flakes from the plates to drop to the sediment space below.

**BATTERY CASE, COYER, AND CAPS.**—The battery case is made of hard rubber or a high—quality plastic. The case must withstand extreme vibration, temperature change, and the corrosive action of the electrolyte. The dividers in the case form individual containers for each element. A container with its element is one cell.

Stiff ridges or ribs are molded in the bottom of the case to form a support for the plates and a sediment recess for the flakes of active material that drop off the plates during the life of the battery. The sediment is thus kept clear of the plates so it will not cause a short circuit across them.

The battery cover is made of the same material as the container and is bonded to and seals the container. The cover provides openings for the two battery posts and a cap for each cell.

Battery caps either screw or snap into the openings in the battery cover. The battery caps (vent plugs) allow gas to escape and prevent the electrolyte from splashing outside the battery. They also serve as spark arresters (keep sparks or flames from igniting the gases inside the battery). The battery is filled through the vent plug openings. Maintenance-free batteries have a large cover that is not removed during normal service.

**CAUTION**

Hydrogen gas can collect at the top of a battery. If this gas is exposed to a flame or spark, it can explode.

**BATTERY TERMINALS.**—Battery terminals provide a means of connecting the battery plates to the electrical system of the vehicle. Either two round post or two side terminals can be used.

Battery terminals are round metal posts extending through the top of the battery cover. They serve as connections for battery cable ends. Positive post will be larger than the negative post. It may be marked with red paint and a positive (+) symbol. Negative post is smaller, may be marked with black or green paint, and has a negative (-) symbol on or near it.

Side terminals are electrical connections located on the side of the battery. They have internal threads that accept a special bolt on the battery cable end. Side terminal polarity is identified by positive and negative symbols marked on the case.

**ELECTROLYTE.**—The electrolyte solution in a fully charged battery is a solution of concentrated sulfuric acid in water. This solution is about 60 percent water and about 40 percent sulfuric acid.

The electrolyte in the lead-acid storage battery has a specific gravity of 1.28, which means that it is 1.28 times as heavy as water. The amount of sulfuric acid in the electrolyte changes with the amount of electrical charge; also the specific gravity of the electrolyte changes with the amount of electrical charge. A fully charged battery will have a specific gravity of 1.28 at 80°F. The figure will go higher with a temperature decrease and lower with a temperature increase.

As a storage battery discharges, the sulfuric acid is depleted and the electrolyte is gradually converted into water. This action provides a guide in determining the state of discharge of the lead-acid cell. The electrolyte that is placed in a lead-acid battery has a specific gravity of 1.280.

The specific gravity of an electrolyte is actually the measure of its density. The electrolyte becomes less dense as its temperature rises, and a low temperature means a high specific gravity. The hydrometer that you use is marked to read specific gravity at 80°F only. Under normal conditions, the temperature of your electrolyte will not vary much from this mark. However, large changes in temperature require a correction in your reading.

For EVERY 10-degree change in temperature ABOVE 80°F, you must ADD 0.004 to your specific gravity reading. For EVERY 10-degree change in temperature BELOW 80°F, you must SUBTRACT 0.004 from your specific gravity reading. Suppose you have just taken the gravity reading of a cell. The hydrometer reads 1.280. A thermometer in the cell indicates an electrolyte temperature of 60°F. That is a normal difference of 20 degrees from the normal of 80°F. To get the true gravity reading, you must subtract 0.008 from 1.280. Thus the specific gravity of the cell is actually 1.272. A hydrometer conversion chart similar to the one shown in figure 2-4 is usually found on the hydrometer. From it, you can obtain the specific gravity correction for temperature changes above or below 80°F.

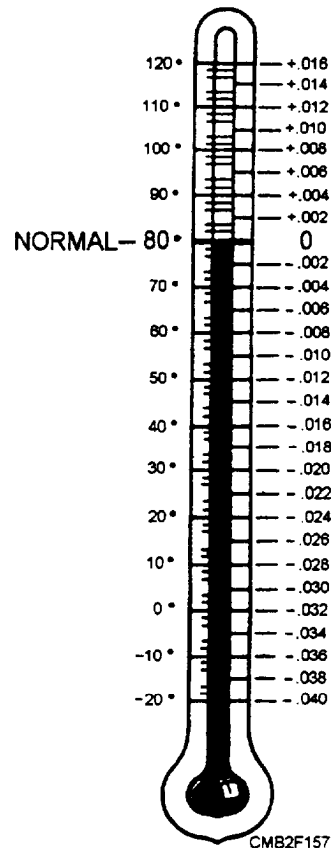

Figure 2-4.—Hydrometer conversion chart.

## Battery Capacity

The capacity of a battery is measured in ampere-hours. The ampere-hour capacity is equal to the product of the current in amperes and the time in hours during which the battery is supplying current. The ampere-hour capacity varies inversely with the discharge current. The size of a cell is determined generally by its ampere-hour capacity. The capacity of a cell depends upon many factors, the most important of which are as follows:

1. The area of the plates in contact with the electrolyte
2. The quantity and specific gravity of the electrolyte
3. The type of separators
4. The general condition of the battery (degree of sulfating, plates buckled, separators warped, sediment in bottom of cells, etc.)
5. The final limiting voltage

## Battery Ratings

Battery ratings were developed by the Society of Automotive Engineers (SAE) and the Battery Council International (BCI). They are set according to national test standards for battery performance. They let the mechanic compare the cranking power of one battery to another. The two methods of rating lead-acid storage batteries are the cold-cranking rating and the reserve capacity rating.

**COLD-CRANKING RATING.**—The cold-cranking rating determines how much current in amperes the battery can deliver for thirty seconds at 0°F while maintaining terminal voltage of 7.2 volts or 1.2 volts per cell. This rating indicates the ability of the battery to crank a specific engine (based on starter current draw) at a specified temperature.

For example, one manufacturer recommends a battery with 305 cold-cranking amps for a small four-cylinder engine but a 450 cold-cranking amp battery for a larger V-8 engine. A more powerful battery is needed to handle the heavier starter current draw of the larger engine.

**RESERVE CAPACITY RATING.**—The reserve capacity rating is the time needed to lower battery terminal voltage below 10.2 V (1.7 V per cell) at a discharge rate of 25 amps. This is with the battery fully charged and at 80°F. Reserve

capacity will appear on the battery as a time interval in minutes.

For example, if a battery is rated at 90 minutes and the charging system fails, the operator has approximately 90 minutes (1 1/2 hours) of driving time under minimum electrical load before the battery goes completely dead.

## Battery Charging

Under normal conditions, a hydrometer reading below 1.240 specific gravity at 80°F is a warning signal that the battery should be removed and charged. Except in extremely warm climates, never allow the specific gravity to drop below 1.225 in tropical climates. This reading indicates a fully charged battery.

When a rundown battery is brought into the shop, you should recharge it immediately. There are several methods for charging batteries; only direct current is used with each method. If only alternating current is available, a rectifier or motor generator must be used to convert to direct current. The two principal methods of charging are (1) constant current and (2) constant voltage (constant potential).

Constant current charging is used on a single battery or a number of batteries in series. Constant voltage charging is used with batteries connected in parallel. (A parallel circuit has more than one path between the two source terminals; a series circuit is a one-path circuit). You should know both methods, although the latter is most often used.

**CONSTANT CURRENT CHARGING.**—With the constant current method, the battery is connected to a charging device that supplies a steady flow of current. The charging device has a rectifier (a gas-filled bulb or a series of chemical disks); thus, the alternating current is changed into direct current. A rheostat (resistor for regulating current) of some kind is usually built into the charger so that you can adjust the amount of current flow to the battery. Once the rheostat is set, the amount of current remains constant. The usual charging rate is 1 amp per positive cell. Thus a 21-plate battery (which has 10 positive plates per cell) should have a charging rate no greater than 10 amps. When using this method of charging a battery, you should check the battery frequently, particularly near the end of the charging period. When the battery is gassing freely and the specific gravity remains constant for 2 hours, you can assume that the battery will take no more charge.

The primary disadvantage of constant current charging is that THE CHARGING CURRENT REMAINS AT A STEADY VALUE UNLESS YOU CHANGE IT. A battery charged with too high current rate would overheat and damage the plates, making the battery useless. Do NOT allow the battery temperature to exceed 110° while charging.

**CONSTANT VOLTAGE CHARGING.—**

Constant voltage charging, also known as constant potential charging, is usually done with a motor generator set. The motor drives a generator (similar to a generator on a vehicle); this generator produces current to charge the battery. The voltage in this type of system is usually held constant. With a constant voltage, the charging rate to a low battery will be high. But as the battery approaches full charge, the opposing voltage of the battery goes up so it more strongly opposes the charging current. This opposition to the charging current indicates that a smaller charge is needed. As the battery approaches full charge, the charging voltage decreases. This condition decreases the ability to maintain a charging current to the battery. As a result, the charging current tapers off to a very low value by the time the battery is fully charged. This principle of operation is the same as that of the voltage regulator on a vehicle.

**CHARGING PRACTICES.—**It is easy to connect the battery to the charger, turn the charging current on, and, after a normal charging period, turn the charging current off and remove the battery. Certain precautions however are necessary both BEFORE and DURING the charging period. These practices are as follows:

1. Clean and inspect the battery thoroughly before placing it on charge. Use a solution of baking soda and water for cleaning; and inspect for cracks or breaks in the container.

**CAUTION**

Do not permit the soda and water solution to enter the cells. To do so would neutralize the acid within the electrolyte.

2. Connect the battery to the charger. Be sure the battery terminals are connected properly; connect positive post to positive (+) terminal and the negative post to negative (-) terminal. The positive terminals of both battery and charger are marked; those unmarked are negative. The positive post of the battery is, in

most cases, slightly larger than the negative post. Ensure all connections are tight.

3. See that the vent holes are clear and open. DO NOT REMOVE BATTERY CARS DURING CHARGING. This prevents acid from spraying onto the top of the battery and keeps dirt out of the cells.
4. Check the electrolyte level before charging begins and during charging. Add distilled water if the level of electrolyte is below the top of the plate.
5. Keep the charging room well ventilated. DO NOT SMOKE NEAR BATTERIES BEING CHARGED. Batteries on charge release hydrogen gas. A small spark may cause an explosion.
6. Take frequent hydrometer readings of each cell and record them. You can expect the specific gravity to rise during the charge. If it does not rise, remove the battery and dispose of it as per local hazardous material disposal instruction.
7. Keep close watch for excessive gassing, especially at the very beginning of the charge when using the constant voltage method. Reduce the charging current if excessive gassing occurs. Some gassing is normal and aids in remixing the electrolyte.
8. Do not remove a battery until it has been completely charged.

**Placing New Batteries in Service**

New batteries may come to you full of electrolyte and fully charged. In this case, all that is necessary is to install the batteries properly in the piece of equipment. Most batteries shipped to NCF units are received charged and dry.

Charged and dry batteries will retain their state of full charge indefinitely so long as moisture is not allowed to enter the cells. Therefore, batteries should be stored in a dry place. Moisture and air entering the cells will allow the negative plates to oxidize. The oxidation causes the battery to lose its charge.

To activate a dry battery, remove the restrictors from the vents and remove the vent caps. Then fill all the cells to the proper level with electrolyte. The best results are obtained when the temperature of the battery and electrolyte is within the range of 60°F to 80°F.

Some gassing will occur while you are filling the battery due to the release of carbon dioxide that is a product of the drying process of the hydrogen sulfide produced by the presence of free sulfur. Therefore, the filling operations should be in a well-ventilated area. These gases and odors are normal and are no cause for alarm.

Approximately 5 minutes after adding electrolyte, the battery should be checked for voltage and electrolyte strength. More than 6 volts or more than 12 volts, depending upon the rated voltage of the battery, indicates the battery is ready for service. From 5 to 6 volts or from 10 to 12 volts indicate oxidized negative plates, and the battery should be charged before use. Less than 5 or less than 10 volts, depending upon the rated voltage, indicates a bad battery, which should not be placed in service.

If, before placing the battery in service, the specific gravity, when corrected to 80°F, is more than .030 points lower than it was at the time of initial filling or if one or more cells gas violently after adding the electrolyte, the battery should be fully charged before use. If the electrolyte reading fails to rise during charging, discard the battery.

Most shops receive ready-mixed electrolyte. Some units may still get concentrated sulfuric acid that must be mixed with distilled water to get the proper specific gravity for electrolyte.

MIXING ELECTROLYTE is a dangerous job. You have probably seen holes appear in a uniform for no apparent reason. Later you remembered replacing a storage battery and having carelessly brushed against the battery.

**WARNING**

When mixing electrolyte, you are handling pure sulfuric acid, which can burn clothing quickly and severely bum your hands and face. Always wear rubber gloves, an apron, goggles, and a face shield for protection against splashes or accidental spilling.

When you are mixing electrolyte, NEVER POUR WATER INTO THE ACID. ALWAYS POUR ACID INTO WATER. If water is added to concentrated sulfuric acid, the mixture may explode or splatter and cause severe burns. Pour the acid into the water slowly, stirring gently but thoroughly all the time. Large quantities of acid may require hours of safe dilution.

Figure 2-5 shows you how much water and acid to mix for obtaining a certain specific gravity. For example, mixing 5 parts of water to 2 parts of acid produces an electrolyte of 1.300, when starting with 1.835 specific gravity acid. If you use 1.400 specific gravity acid, 2 parts water and 5 parts acid will give the same results.

Let the mixed electrolyte cool down to room temperature before adding it to the battery cells. Hot electrolyte will eat up the cell plates rapidly. To be on the safe side, do not add the electrolyte if its temperature is above 90°F. After filling the battery cells, let the electrolyte cool again because more heat is generated by its contact with the battery plates. Next, take hydrometer readings. The specific gravity of the electrolyte will correspond quite closely to the values on the mixing chart if the parts of water and acid are mixed correctly.

**Battery Maintenance**

If a battery is not properly maintained, its service life will be drastically reduced. Battery maintenance should be done during every PM cycle. Complete battery maintenance includes the following:

- Visually checking the battery.
- Checking the electrolyte level in cells on batteries with caps. Adding water if the electrolyte level is low.
- Cleaning off corrosion around the battery and battery terminals.

Specific Gravity Desired	Using 1.835 Sp. Gr. Acid		using 1.400 Sp. Gr. Acid	
	Parts of Water	Parts of Acid	Parts of Water	Parts of Acid
1.400	3	2	--	--
1.345	2	1	1	7
1.300	5	2	2	5
1.290	8	3	9	20
1.275	11	4	11	20
1.250	13	4	3	4
1.225	11	3	1	1
1.200	13	3	13	10

CM82F158

Figure 2-5.—Electrolyte mixing chart.

- Checking the condition of the battery by testing the state of charge.

**VISUAL INSPECTION OF THE BATTERY.**—Battery maintenance should always begin with a thorough visual inspection. Look for signs of corrosion on or around the battery, signs of leakage, a cracked case or top, missing caps, and loose or missing hold-down clamps.

**CHECKING ELECTROLYTE LEVEL AND ADDING WATER.**—On vent cap batteries, the electrolyte level can be checked by removing the caps. Some batteries have a fill ring which indicates the electrolyte level. The electrolyte should be even with the fill ring. If there is no fill ring, the electrolyte should be high enough to cover the tops of the plates. Some batteries have an electrolyte-level indicator (Delco Eye). This gives a color code visual indication of the electrolyte level, with black indicating that the level is okay and white meaning a low level.

If the electrolyte level in the battery is low, fill the cells to the correct level with **DISTILLED WATER** (purified water). Distilled water should be used because it does not contain the impurities found in tap water. Tap water contains many chemicals that reduce battery life. The chemicals contaminate the electrolyte and collect in the bottom of the battery case. If enough contaminants collect in the bottom of the case, the cell plates **SHORT OUT**, ruining the battery.

If water must be added at frequent intervals, the charging system may be overcharging the battery. A faulty charging system can force excessive current into the battery. Battery gassing can then remove water from the battery.

Maintenance-free batteries do **NOT** need periodic electrolyte service under normal conditions. It is designed to operate for long periods without loss of electrolyte.

**CLEANING THE BATTERY AND TERMINALS.**—If the top of the battery is dirty, using a stiff bristle brush, wash it down with a mixture of baking soda and water. This action will neutralize and remove the acid-dirt mixture. Be careful not to allow cleaning solution to enter the battery.

To clean the terminals, remove the cables and inspect the terminal posts to see if they are deformed or broken. Clean the terminal posts and the inside surfaces of the cable clamps with a cleaning tool before replacing them on the terminal posts.

## **CAUTION**

Do **NOT** use a scraper or knife to clean battery terminals. This action removes too much metal and can ruin the terminal connection.

When reinstalling the cables, coat the terminals with petroleum or white grease. This will keep acid fumes off the connections and keep them from corroding again. Tighten the terminals just enough to secure the connection. Overtightening will strip the cable bolt threads.

**CHECKING BATTERY CONDITION.**—When measuring battery charge, you check the condition of the electrolyte and the battery plates. As a battery becomes discharged, its electrolyte has a larger percentage of water. Thus the electrolyte of a discharged battery will have a lower specific gravity number than a fully charged battery. This rise and drop in specific gravity can be used to check the charge in a battery. There are several ways to check the state of charge of a battery.

Nonmaintenance-free batteries can have the state of charge checked with a hydrometer. The hydrometer tests specific gravity of the electrolyte. It is fast and simple to use. There are three types of hydrometers—the float type, the ball type, and needle type.

To use a **FLOAT TYPE HYDROMETER**, squeeze and hold the bulb. Then immerse the other end of the hydrometer in the electrolyte. Then release the bulb. This action will fill the hydrometer with electrolyte. Hold the hydrometer even with your line of sight and compare the numbers on the hydrometer with the top of the electrolyte.

Most float type hydrometers are **NOT** temperature correcting. However, the new models will have a built-in thermometer and a conversion chart that allow you to calculate the correct temperature.

The **BALL TYPE HYDROMETER** is becoming more popular because you do not have to use a temperature conversion chart. The balls allow for a change in temperature when submersed in electrolyte. This allows for any temperature offset.

To use a ball type hydrometer, draw electrolyte into the hydrometer with the rubber bulb at the top. Then note the number of balls floating in the electrolyte. Instructions on or with the hydrometer will tell you whether the battery is fully charged or discharged.

A **NEEDLE TYPE HYDROMETER** uses the same principles as the ball type. When electrolyte is drawn into the hydrometer, it causes the plastic needle to register specific gravity.

A fully charged battery should have a hydrometer reading of at least 1.265 or higher. If below 1.265, the battery needs to be recharged. or it may be defective. A discharged battery could be caused by the following:

- Defective battery
- Charging system problems
- Starting system problems
- Poor cable connections
- Engine performance problems requiring excessive cranking time
- Electrical problems drawing current out of the battery with the ignition OFF

defective battery can be found by using a hydrometer to check each cell. If the specific gravity in any cell varies excessively from other cells (25 to 50 points), the battery is bad. Cells with low readings may be shorted. When all of the cells have equal specific gravity, even if they are low, the battery can usually be recharged.

On maintenance-free batteries a charge indicator eye shows the battery charge. The charge indicator changes color with levels of battery charge. For example, the indicator may be green with the battery fully charged. It may turn black when discharged or yellow when the battery needs to be replaced. If there is no charge indicator eye or when in doubt of its reliability, a voltmeter and ammeter or a load tester can also be used to determine battery condition quickly.

### Battery Test

As a mechanic you will be expected to test batteries for proper operation and condition. These tests are as follows:

- Battery leakage test
- Battery terminal test
- Battery voltage test
- Cell voltage test
- Battery drain test
- Battery load test (battery capacity test)
- Quick charge test

**BATTERY LEAKAGE TEST.**—A battery leakage test will determine if current is discharging

across the top of the battery. A dirty battery can discharge when not in use. This condition shortens battery life and causes starting problems.

To perform a battery leakage test, set a voltmeter on a low setting. Touch the probes on the battery, as shown in figure 2-6. If any current is registered on the voltmeter, the top of the battery needs to be cleaned.

**BATTERY TERMINAL TEST.**—The battery terminal test quickly checks for poor electrical connection between the terminals and the battery cables. A voltmeter is used to measure voltage drop across terminals and cables.

To perform a battery terminal test (fig. 2-7), connect the negative voltmeter lead to the battery cable end. Touch the positive lead to the battery terminal. With the ignition or injection system disabled so that the engine will not start, crank the engine while watching the voltmeter reading.

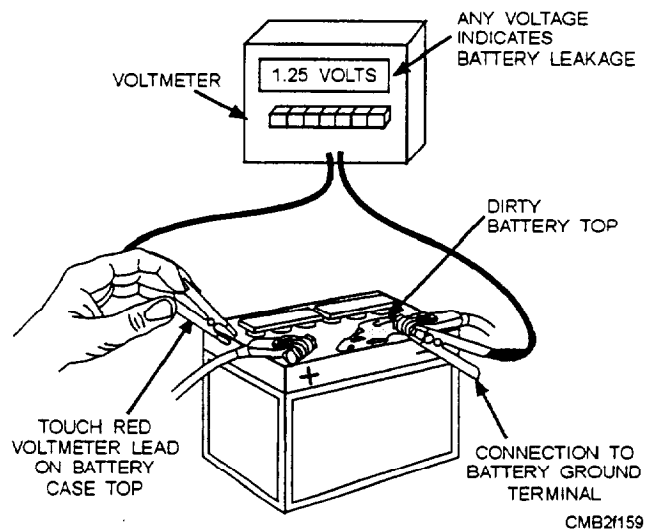

Figure 2-6.—Battery leakage test.

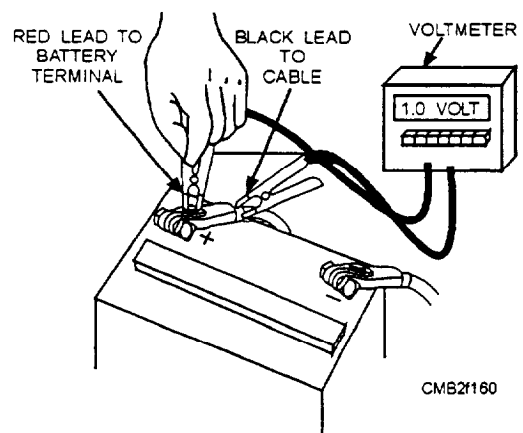

Figure 2-7.—Battery terminal test.

If the voltmeter reading is .5 volts or above, there is high resistance at the battery cable connection. This indicates that the battery connections need to be cleaned. A good, clean battery will have less than a .5 volt drop.

**BATTERY VOLTAGE TEST.**—The battery voltage test is done by measuring total battery voltage with an accurate voltmeter or a special battery tester (fig. 2-8). This test determines the general state of charge and battery condition quickly.

The battery voltage test is used on maintenance-free batteries because these batteries do not have caps that can be removed for testing with a hydrometer. To perform this test, connect the voltmeter or battery tester across the battery terminals. Turn on the vehicle headlights or heater blower to provide a light load. Now read the meter or tester. A well-charged battery should have over 12 volts. If the meter reads approximately 11.5 volts, the battery is not charged adequately, or it may be defective.

**CELL VOLTAGE TEST.**—The cell voltage test will let you know if the battery is discharged or defective. Like a hydrometer cell test, if the voltage reading on one or more cells is .2 volts or more lower than the other cells, the battery must be replaced.

To perform a cell voltage test (fig. 2-9), use a low voltage reading voltmeter with special cadmium (acid resistant metal) tips. Insert the tips into each cell, starting at one end of the battery and work your way to the other. Test each cell carefully. If the cells are low, but equal, recharging usually will restore the battery. If cell voltage readings vary more than .2 volts, the battery is BAD.

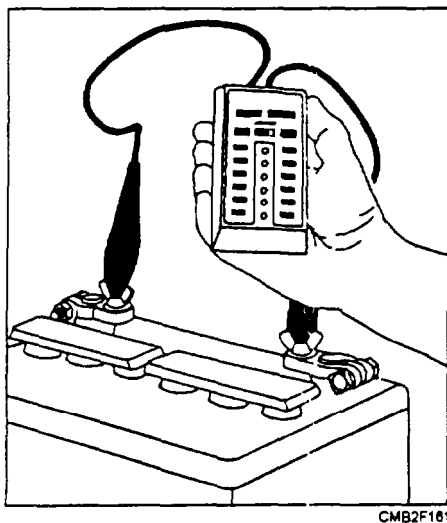

Figure 2-8.—Battery voltage test performed with a battery tester.

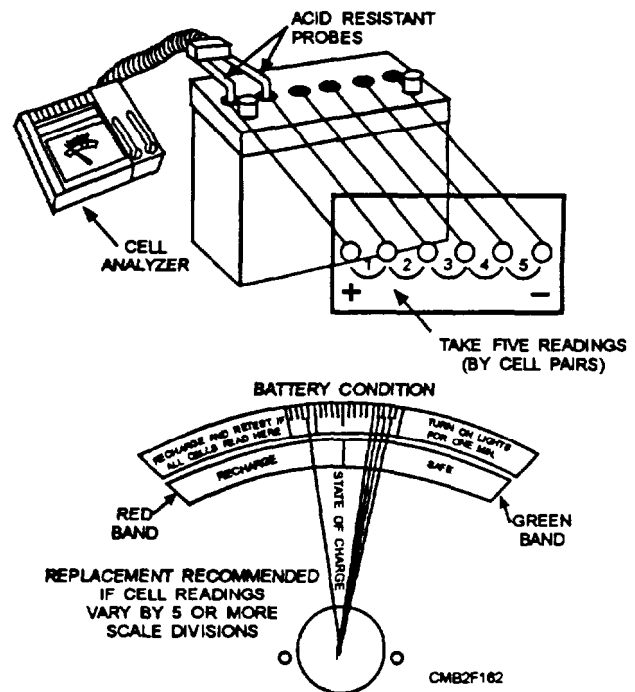

Figure 2-9.—Cell voltage test.

**BATTERY DRAIN TEST.**—A battery drain test checks for abnormal current draw with the ignition off. If a battery goes dead without being used, you need to check for a current drain.

To perform a battery drain test, set up an ammeter, as shown in figure 2-10. Pull the fuse if the vehicle has a dash clock. Close all doors and trunk (if applicable). Then read the ammeter. If everything is off, there should be a zero reading. Any reading indicates a problem. To help pinpoint the problem, pull fuses one at a time until there is a zero reading on the ammeter. This action isolates the circuit that has the problem.

**BATTERY CAPACITY TEST.**—A battery load test, also termed a battery capacity test, is the best method to check battery condition. The battery load test measures the current output and performance of the battery under full current load. It is one of the most common and informative battery tests used today.

Before load testing a battery, you must calculate how much current draw should be applied to the battery. If the ampere-hour rating of the battery is given, load the battery to three times its amp-hour rating. For example, if the battery is rated at 60 amp-hours, test the battery at 180 amps ( $60 \times 3 = 180$ ). The majority of the batteries are now rated in SAE cold-cranking amps, instead of amp-hours. To determine the load test for these batteries, divide the cold-crank



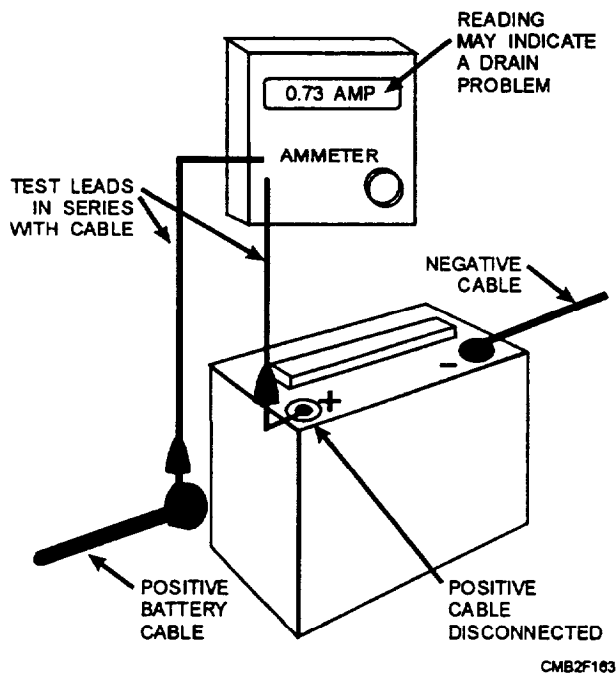

Figure 2-10.—Battery drain test setup.

rating by two. For example, a battery with 400 cold-cranking amps rating should be loaded to 200 amps ( $400 \div 2 = 200$ ). Connect the battery load tester, as shown in figure 2-11. Turn the control knob until the ammeter reads the correct load for your battery.

After checking the battery charge and finding the amp load value, you are ready to test battery output. Make sure that the tester is connected properly. Turn the load control knob until the ammeter reads the correct load for your battery. Hold the load for 15 seconds. Next, read the voltmeter while the load is

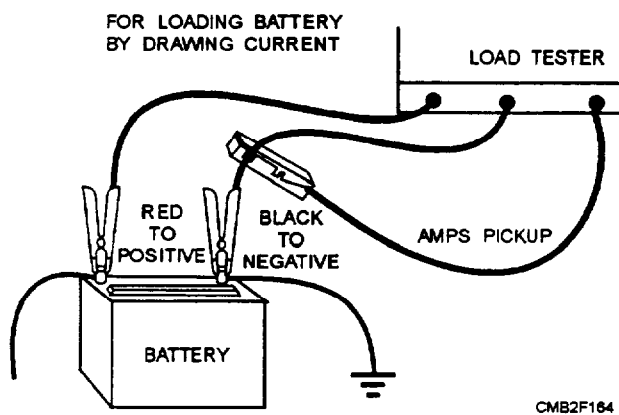

Figure 2-11.—Instrument hookup for battery capacity test.

applied. Then turn the load control completely off so the battery will not be discharged. If the voltmeter reads 9.5 volts or more at room temperature, the battery is good. If the battery reads below 9.5 volts at room temperature, battery performance is poor. This condition indicates that the battery is not producing enough current to run the starting motor properly.

Familiarize yourself with proper operating procedures for the type of tester you have available. Improper operation of electrical test equipment may result in serious damage to the test equipment or the unit being tested.

**QUICK CHARGE TEST.**—The quick charge test, also known as 3-minute charge test, determines if the battery is sulfated. If the results of the battery load test are poor, fast charge the battery. Charge the battery for 3 minutes at 30 to 40 amps. Test the voltage while charging. If the voltage goes ABOVE 15.5 volts, the battery plates are sulfated and the battery needs to be replaced.

## GENERATORS

The generator is a machine that applies the principle of electromagnetic induction to convert mechanical energy, supplied by the engine, into electrical energy. The generator restores to the battery the energy that has been used up in cranking the engine. Whether the energy required for the rest of the electrical system is supplied directly by the generator, by the battery, or by a combination of both depends on the conditions under which the generator is operating.

The two types of generators are as follows:

- The dc generator supplies electrical energy directly to the battery and or electrical system through various regulating devices.
- The ac generator (alternator) has the same function as the dc generator but because only direct current can be used to charge a battery, a component, called a rectifier, must be used to convert from alternating to direct current. The ac generator (alternator) will be explained in further detail later in this chapter.

### Direct-Current (dc) Generator

The dc generator (fig. 2-12) essentially consists of an armature, a field frame, field coils, and a commutator with brushes to establish electrical contact with the rotating element. The magnetic field of the generator usually is produced by the

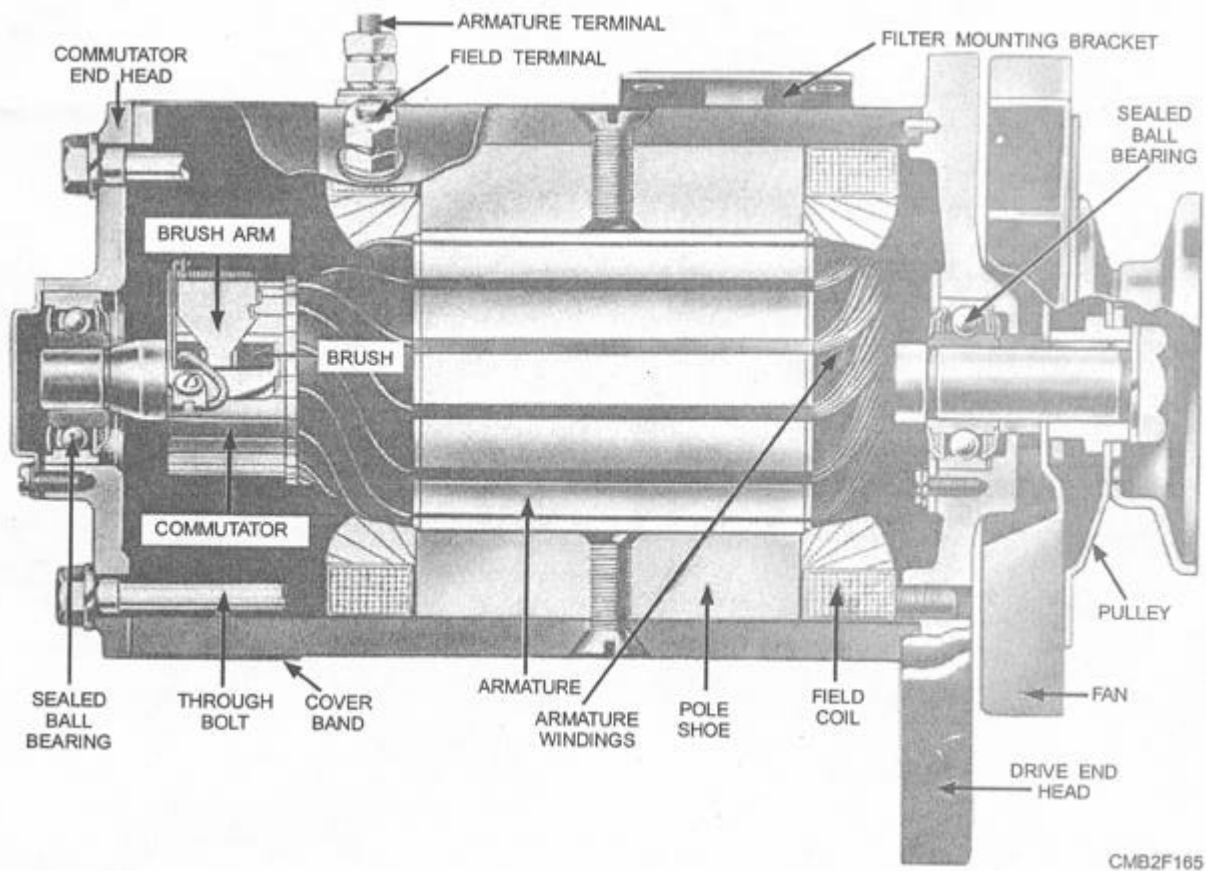

Figure 2-12.—Sectional view of a dc generator.

electromagnets or poles magnetized by current flowing through the field coils. Soft iron pole pieces (or pole shoes) are contained in the field frame that forms the magnetic circuit between the poles. Although generators may be designed to have any even number of poles, two- and four- pole frames are the most common. The field coils are connected in series. In the two-pole type frame, the magnetic circuit flows through only a part of the armature core; therefore, the armature must be constructed according to the number of field poles because current is generated when the coil (winding on the armature) moves across each magnetic circuit.

The current is collected from the armature coils by brushes (usually made of carbon) that make rubbing contact with a commutator. The commutator consists of a series of insulated copper segments mounted on one end of the armature, each segment connecting to one or more armature coils. The armature coils are connected to the external circuits (battery, lights, or ignition) through the commutator and brushes. Current

induced in the armature coils thus is able to flow to the external circuits.

There are two types of field circuits, determined by the point at which the field circuit is grounded, which are as follows:

- One circuit, referred to as the "A" circuit, shunts the field current from the insulated brushes through the field winding grounding externally at the regulator.
- In the other, the "B" circuit, the field current is shunted from the armature series winding in the regulator to the generator field windings, grounding internally within the generator.

The three basic design factors that determine generator output are (1) the speed of armature rotation, (2) the number of armature conductors, and (3) the strength of the magnetic field. Any of these design factors could be used to control the generator voltage and current. However, the simplest method is to determine the strength of the magnetic field and thus limit the voltage and current output of the generator.

## Regulation of Generator Output

The fields of the generator depend upon the current from the armature of the generator for magnetization. Because the current developed by the generator increases in direct proportion to its speed, the fields become stronger as the speed increases and, correspondingly, the armature generates more current. The extreme variations in speed of the automotive engine make it necessary to regulate output of the generator to prevent excessive current or voltage overload. On the average unit of CESE, a charging current in excess of 12 to 15 amperes is harmful to a fully charged battery if continued for too long.

Regulators are of two types, functioning to regulate either voltage or current. The voltage regulator regulates the voltage in the electric system and prevents excessive voltage, which can cause damage to the electric units and overcharge the battery. The current regulator is a current limiter; it prevents the generator output from increasing beyond the rated output of the generator.

Regulation of voltage only might be satisfactory from the standpoint of the battery; however, if the battery were badly discharged or if a heavy electrical load were connected, the heavy current might overload itself to supply the heavy current demand. Therefore, both current and voltage controls are used in a charging system.

In most applications, a regulator assembly consists of a cutout relay, current regulator, and voltage regulator (fig. 2-13). Each unit contains a separate core, coil, and set of contacts. The regulator assembly provides full control of the shunt-type generator under all conditions. Either the current regulator or the voltage regulator may be operating at any one time, but in no case do they both operate at the same time.

When the electric load requirements are high and the battery is low, the current regulator will operate to prevent the generator output from exceeding its safe maximum. In this case, the voltage is not sufficient to cause the voltage regulator to operate. But if the load requirements are reduced or the battery begins to come up to charge, the line voltage will increase to a value sufficient to cause the voltage regulator to operate. When this happens, the generator output is reduced; it is no longer sufficiently high to cause the current regulator to operate. All regulation is then dependent on the voltage regulator. Figure 2-14 shows a schematic wiring diagram of a typical dc charging circuit. In this circuit, two resistances are connected in

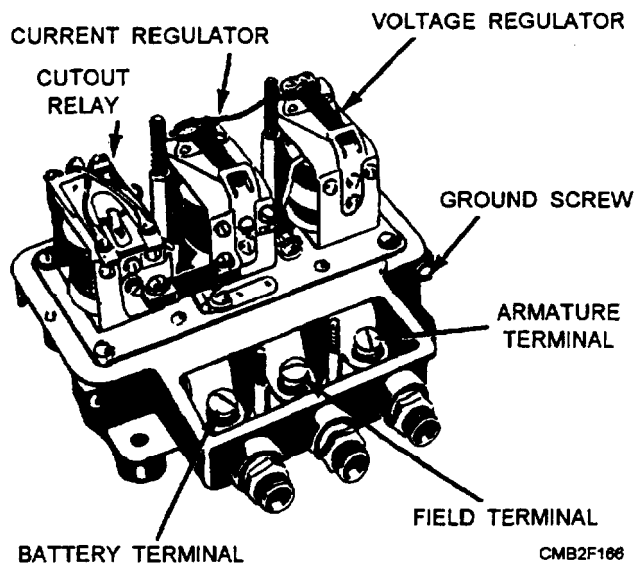

Figure 2-13.—Regulator assembly with cover removed.

parallel into the generator field circuit when the current regulator points open. This provides a low value of resistance, which is sufficient to prevent the generator output from exceeding its safe maximum. When the voltage regulator contact points open, only one resistance is inserted into the generator field circuit, and this provides a higher value of resistance. The voltage regulator must employ a higher resistance because it must reduce the generator output as it operates, and it requires more resistance to reduce the output than merely to prevent the output from going beyond the safe maximum of the generator.

For some special applications, you may find a combined current-voltage regulator. In this case, the regulators are combined in a single unit. The regulator assembly will consist of two (regulator and circuit breaker) instead of three units.

The regulators just described are known as electromagnetic vibrating-contact regulators. The points on the armatures of the regulators may open and close as many as 300 times in one second to achieve the desired regulation.

The transistor type regulator is being used in late model equipment. This regulator has no moving parts. It consists of transistors, diodes, condensers, and resistors. Some models have two filter condensers, while others have only one.

Adjustments are provided on some types of regulators and should be made only with the use of the manufacturer's instructions and the recommended testing equipment. TRIAL AND ERROR METHOD OF REPAIR WILL NOT WORK.

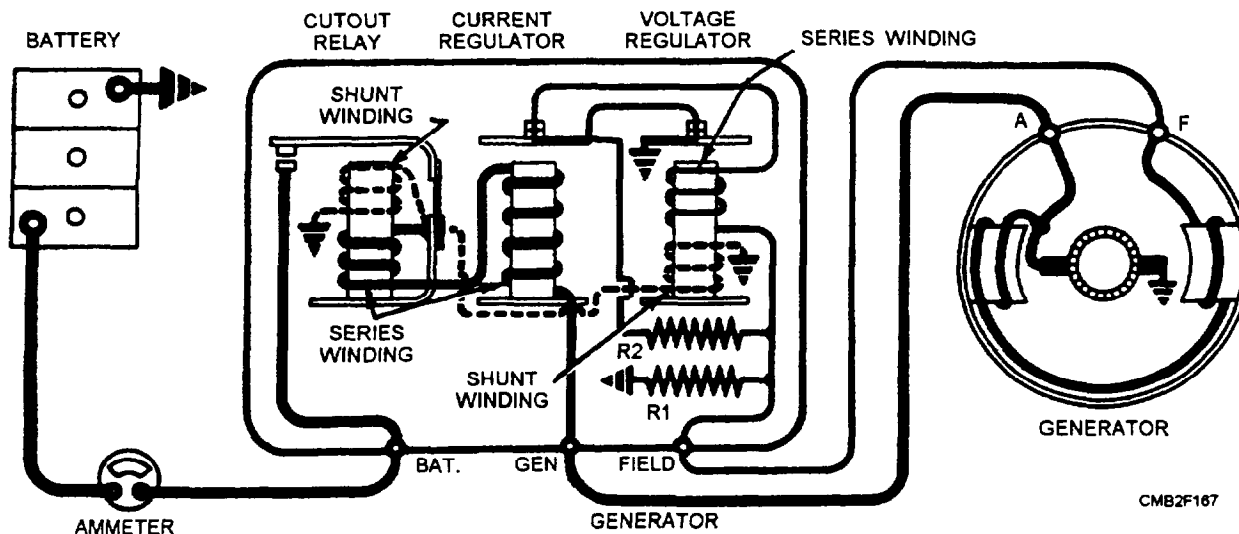

Figure 2-14.—Schematic wiring diagram of a typical dc charging circuit.

## Generator Maintenance

The dc generator requires periodic cleaning, lubrication, inspection of brushes and commutator, and testing of brush spring tension. In addition, the electrical connections need attention to ensure clean metal-to-metal contact and tightness.

Some generators have hinged cap oilers. Lubricate these with a few drops of medium weight oil at each maintenance cycle. Do not overlubricate, because an excessive amount of oil can get on the commutator and prevent the brushes from functioning properly.

Visually and manually inspect the condition of all cables, clamps, wiring, and terminal connections. See that the generator drive pulley is tight on the shaft and that the belt is in good condition and adjusted properly. Also, ensure that the generator is securely mounted and has a good ground.

Remove the cover band, on generator so equipped, and inspect the inner surface of the generator cover band for tiny globules of solder. If any solder is found, the generator is producing excessive current and has melted the solder used in connecting the armature wires to the commutator bars. This condition requires removal of the generator to repair or replace the armature.

If no solder is found, inspect the commutator, brushes, and electrical connections. If the commutator is dirty or slightly rough, using 00 sandpaper can smooth it. NEVER use emery cloth on the commutator.

Once the commutator has been sanded, blow compressed air through the interior of the generator to remove any excess dirt and brush particles. Lift the

brushes in the brush holder to see that they are free to operate and have sufficient tension to prevent arcing and burning of the commutator and brushes. If brushes are worn down to one half of their original length, replace them.

Most generators today are not equipped with cover bands. They may have open slots over the commutator or be sealed entirely. On those with open slots, the commutator can be sanded through the slots, but brush removal can only be accomplished by removing the commutator end frame. On sealed units, maintenance can only be performed after disassembly.

## Generator Repair

Generators are disassembled only when major repairs are to be made (fig. 2-15). Other than cleaning commutators and replacing worn-out brushes during periodic maintenance, generators require very few repairs during normal service life. However, if neglected, generators will develop problems that cannot be remedied in the field.

Before removing a generator suspected of being faulty, you should check the battery, as discussed earlier, and the generator output. Refer to the manufacturer's manual for correct generator output specifications and proper testing procedures. If the generator is operating properly and the battery, wiring, and connections are in operating condition, a defective voltage regulator is indicated in which, in most cases, the regulator is removed and replaced. However, if the generator is not producing the specified amperes at the specified engine speed, then it must be removed from the vehicle and either repaired or replaced.

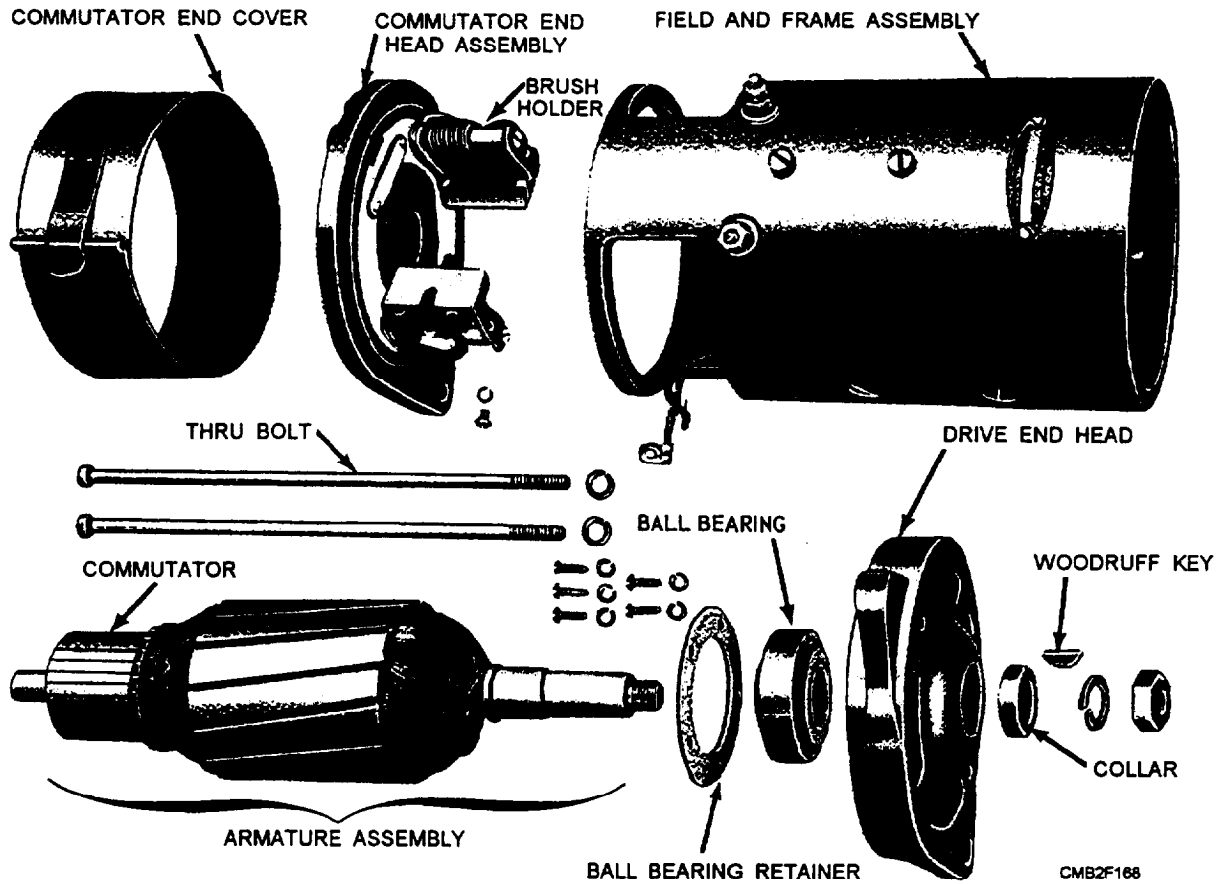

Figure 2-15.—Disassembled view of a two-brush generator.

**TESTING FIELD COILS.**—To test the generator field, you must disconnect the grounded ends from the frame. Place one probe of the test lamp circuit on the field terminal end of the coils and the other probe on the grounded end. If the lamp lights, the field circuit is complete. However, because of the resistance in the field coil wire, it should not bum with normal brilliancy. Normal brilliancy of the test light bulb indicates a possible short circuit between the coils of the field. If the light does not burn, the field is open-circuited.

A grounded field coil is located by placing one test probe on the field terminal and the other on the generator frame (fig. 2-16). If the test lamp lights, the field is grounded. The ground may be caused by frayed wires at the coil ends. In most cases, grounds and open circuits in the field coils cannot be satisfactorily repaired. The defective field coil must then be replaced.

Test for grounds, shorts, and open circuits in the field coils can also be made with an ohmmeter. The ohmmeter has test probes similar to the test lamp circuit. When these test probes are connected to the

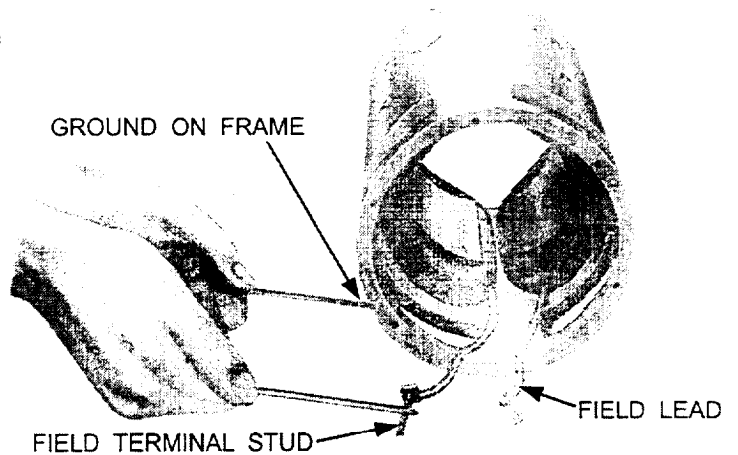

Figure 2-16.—Testing field coils for ground. CMB2F169

field coil ends, the ohmmeter will measure the actual resistance of the coil. If the specified resistance of a field coil is given in the manufacturer's manual, also obtained by measuring a new coil, you can compare values obtained through tests. For example, a short-circuited field coil would have practically no resistance and the ohmmeter would register near zero; or the ohmmeter would register excessively high resistance in testing a coil having an open circuit. By

following the manufacturer's instructions in using the ohmmeter, field coil tests can be made more quickly and accurately than by using a test lamp circuit.

**ARMATURE TEST.**—There are two practical tests for locating shorts, opens, and grounds in armatures—the growler test and the bar-to-bar test.

To test for short circuits, place the armature on the V-block of the growler and turn on the current. With a thin metal strip (hacksaw blade is good) held over the core, as shown in figure 2-17, rotate the armature slowly through a complete revolution. If a short is present, the steel strip will become magnetized and vibrate. To find out whether the armature coils of the commutator are short-circuited, clean between the commutator segments and repeat the test. Should the thin metal strip still vibrate, the armature is short-circuited internally and must be replaced.

Not all armatures can be tested for short circuits by the method just described. These armatures can be identified by excessive vibration of the saw blade all around the armature during the test. With these armatures, test for short circuits by using the milliampere contacts on an ac millimeter, as shown in figure 2-18. In doing so, keep the armature stationary in the V-block and move the contacts around the commutator until the highest reading is obtained. Then turn the armature to bring each pair of segments under

the contacts and read the milliammeter at the same time. The readings should be nearly the same for each pair of adjacent bars. If a coil is short-circuited, the milliammeter reading will drop to almost zero.

Test the armature for grounds by using the test light circuit, which is a part of most modern factory-built growlers (fig. 2-19). Place the armature on the V-block and touch one of the test probes to the

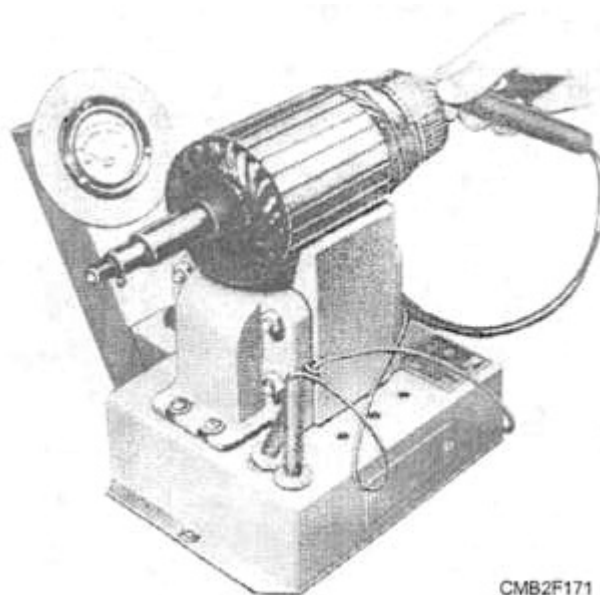

Figure 2-18.—Testing an armature for a short circuit with a milliammeter.

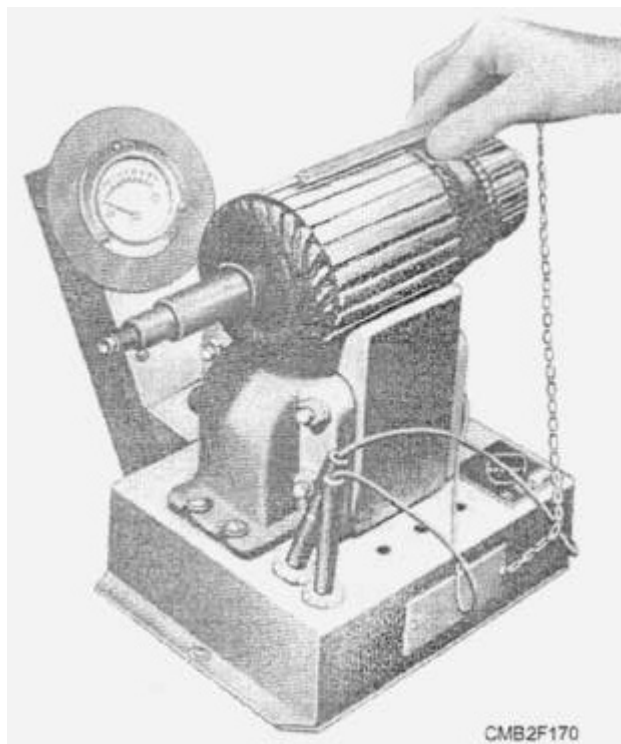

Figure 2-17.—Using an armature growler.

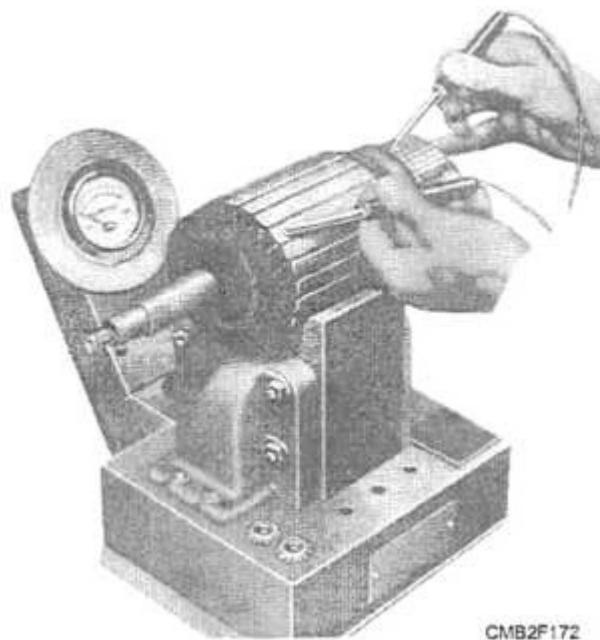

Figure 2-19.—Testing an armature for grounds.

armature core iron. Touch the other probe to each commutator segment in turn. If the armature is grounded, the bulb in the base of the growler will light. In contacting armature surfaces with the test probes, do not touch the bearing or the brush surfaces of the commutator. The arc would burn or pit the smooth finish. Replace the armature if it is grounded.

In testing individual armature coils for open circuits, use the test probes, as shown in figure 2-20. Place them on the riser part of adjacent commutator

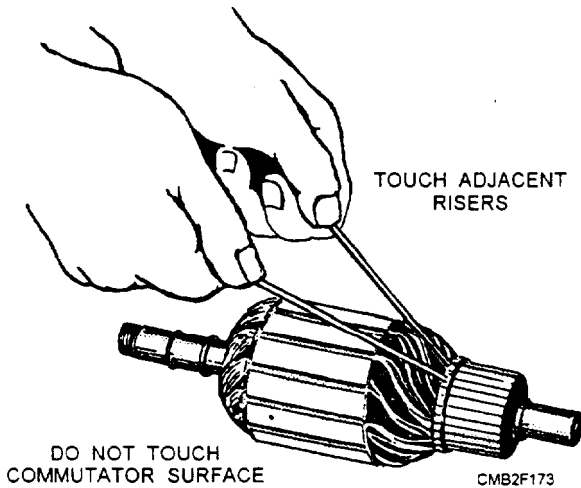

Figure 2-20.—Testing an armature for open circuits.

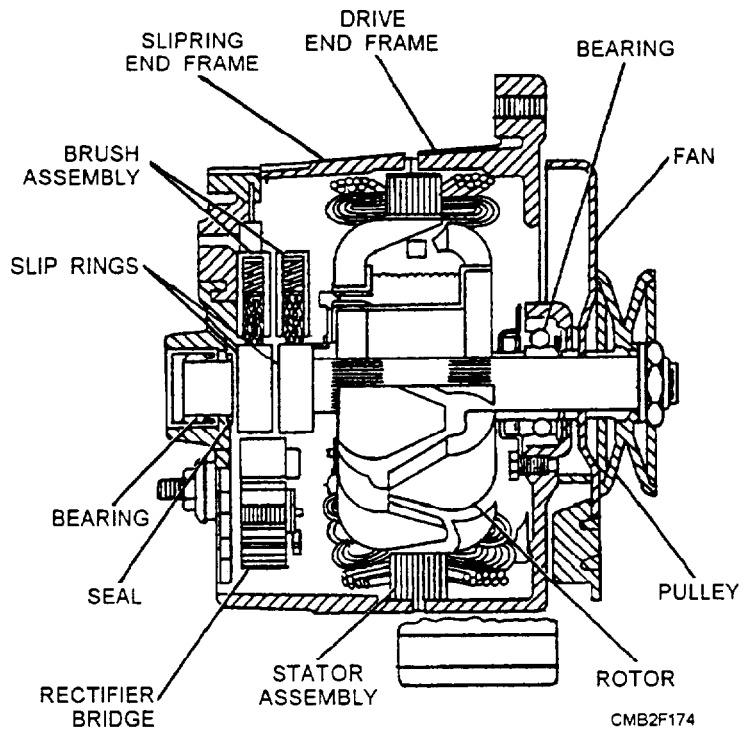
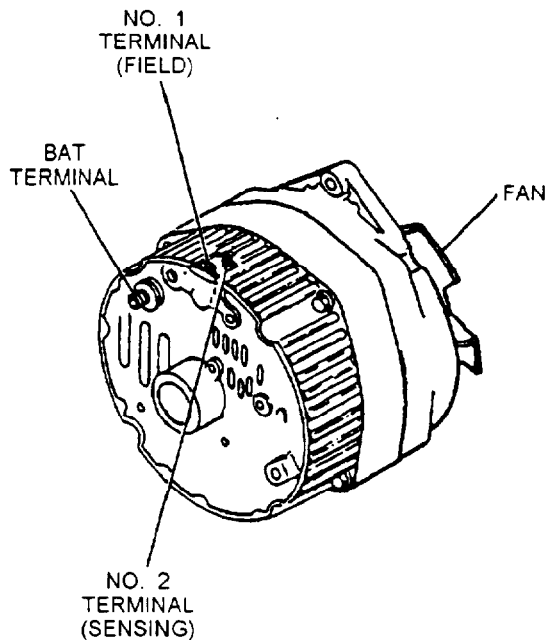

Figure 2-21.—Typical alternator.

bars, not on the brush surfaces. If the test lamp does not light, there is a break some where in the coil. Repeat this test on every pair of adjacent bars. Do this by walking the probes from bar to bar. Should you find an open coil, the fault may be at the commutator connectors where it is possible to make repairs with a little solder. If a coil is open-circuited internally, the armature should be discarded.

## ALTERNATORS

The alternator (fig. 2-21) has replaced the dc generator because of its improved efficiency. It is smaller, lighter, and more dependable than the dc generator. The alternator also produces more output during idle which makes it ideal for late model vehicles.

The alternator has a spinning magnetic field. The output windings (stator) are stationary. As the magnetic field rotates, it induces current in the output windings.

### Alternator Construction

Knowledge of the construction of an alternator is required before you can understand the proper operation, testing procedures, and repair procedures applicable to an alternator.

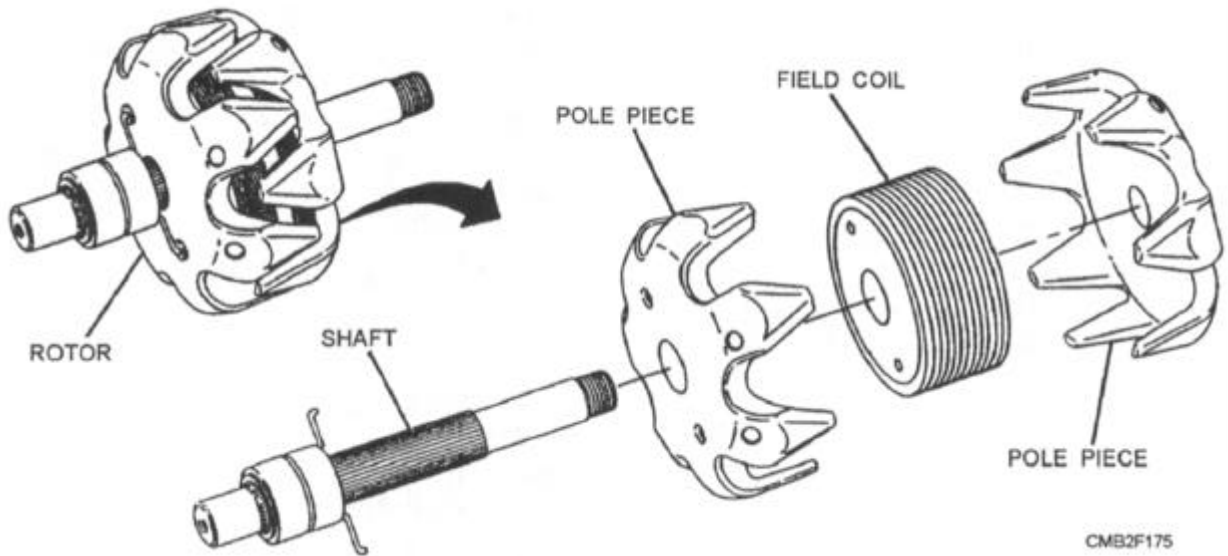

Figure 2-22.—Rotor assembly.

The primary components of an alternator are as follows:

- ROTOR ASSEMBLY (rotor shaft, slip rings, claw poles, and field windings)
- STATOR ASSEMBLY (three stator windings or coils, output wires, and stator core)
- RECTIFIER ASSEMBLY (heat sink, diodes, diode plate, and electrical terminals)

**ROTOR ASSEMBLY** (fig. 2-22).—The rotor consists of field windings (wire wound into a coil placed over an iron core) mounted on the rotor shaft. Two claw-shaped pole pieces surround the field windings to increase the magnetic field.

The fingers on one of the claw-shaped pole pieces produce south (S) poles and the other produces north (N) poles. As the rotor rotates inside the alternator, alternating N-S-N-S polarity and ac current is produced (fig. 2-23). An external source of electricity is required to excite the magnetic field of the alternator.

Slip rings are mounted on the rotor shaft to provide current to the rotor windings. Each end of the field coil connects to the slip rings.

**STATOR ASSEMBLY** (fig. 2-24).—The stator produces the electrical output of the alternator. The stator, which is part of the alternator frame when assembled, consists of three groups of windings or coils which produce three separate ac currents. This is known as three-phase output. One end of the windings is connected to the stator assembly and the other is connected to a rectifier assembly. The windings are

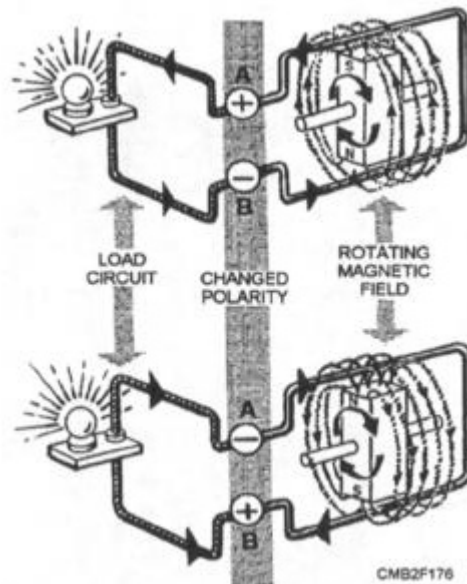

Figure 2-23.—Simple alternator illustrating reversing magnetic field and resulting current flow.

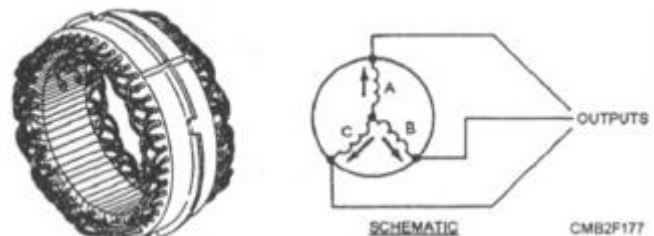

Figure 2-24.—Stator assembly.

wrapped around a soft laminated iron core that concentrates and strengthens the magnetic field around the stator windings. There are two types of stators—Y -type stator and delta-type stator.



The Y-type stator (fig. 2-25) has the wire ends from the stator windings connected to a neutral junction. The circuit looks like the letter Y. The Y-type stator provides good current output at low engine speeds.

The delta-type stator (fig. 2-26) has the stator wires connected end-to-end. With no neutral junction, two circuit paths are formed between the diodes. A delta-type stator is used in high output alternators.

**RECTIFIER ASSEMBLY.**—The rectifier assembly, also known as a diode assembly, consists of six diodes used to convert stator ac output into dc current. The current flowing from the winding is allowed to pass through an insulated diode. As the current reverses direction, it flows to ground through a grounded diode. The insulated and grounded diodes prevent the reversal of current from the rest of the charging system. By this switching action and the number of pulses created by motion between the windings of the stator and rotor, a fairly even flow of current is supplied to the battery terminal of the alternator.

The rectifier diodes are mounted in a heat sink (metal mount for removing excess heat from electronic parts) or diode bridge. Three positive diodes are press-fit in an insulated frame. Three negative diodes are mounted into an uninsulated or grounded frame.

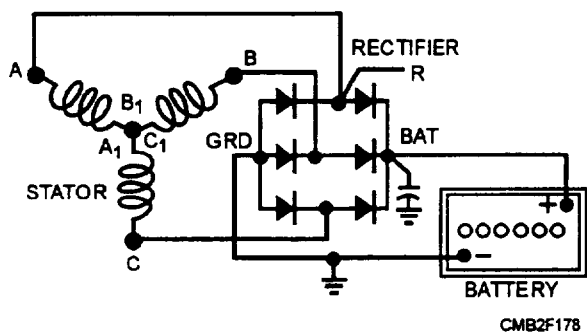

Figure 2-25.—Electrical diagram indicating a Y-type stator.

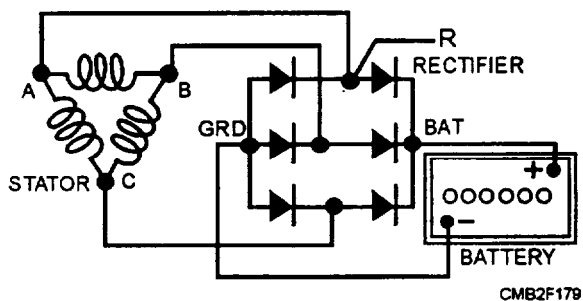

Figure 2-26.—Electrical diagram indicating a delta-type stator.

When an alternator is producing current, the insulated diodes pass only outflowing current to the battery. The diodes provide a block, preventing reverse current flow from the alternator. Figure 2-27 shows the flow of current from the stator to the battery.

A cross-sectional view of a typical diode is shown in figure 2-28. Note that the figure also shows the diode symbol used in wiring diagrams. The arrow in this symbol indicates the only direction that current will flow. The diode is sealed to keep moisture out.

### Alternator Operation

The operation of an alternator is somewhat different than the dc generator. An alternator has a rotating magnet (rotor) which causes the magnetic lines of force to rotate with it. These lines of force are cut by the stationary (stator) windings in the alternator frame, as the rotor turns with the magnet rotating the N and S poles to keep changing positions. When S is up and N is down, current flows in one direction, but when N is up and S is down, current flows in the opposite direction. This is called alternating current as it changes direction twice for each complete revolution. If the rotor speed were increased to 60 revolutions per second, it would produce 60-cycle alternating current.

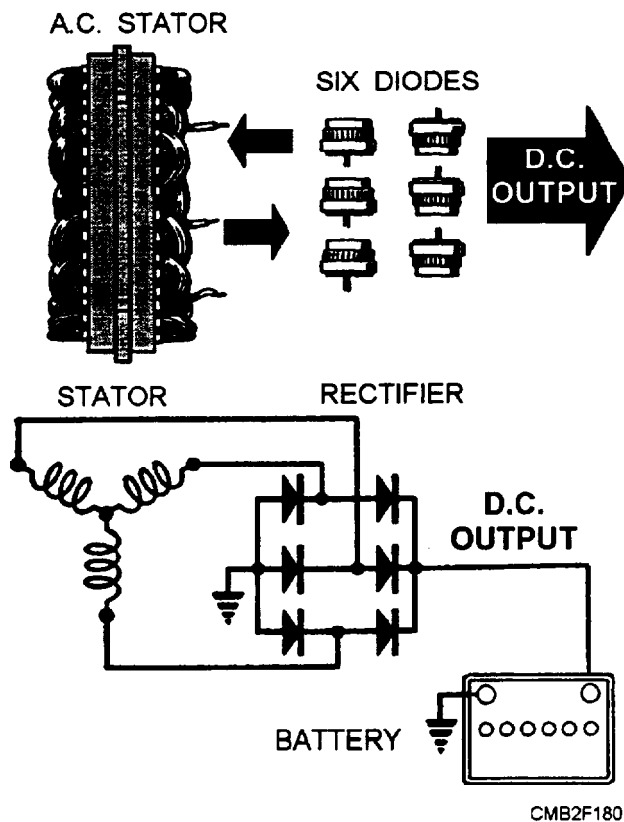

Figure 2-27.—Current flow from the stator to the battery.

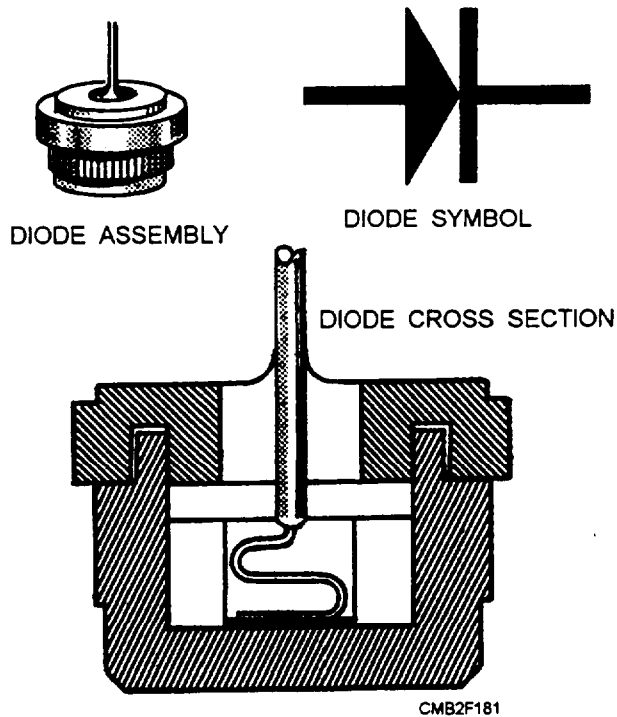

Figure 2-28.—Typical diode.

Since the engine speed varies in a vehicle, the frequency also varies with the change of speed. Likewise, increasing the number of pairs of magnetic north and south poles will increase the frequency by the number pair of poles. A four-pole generator can generate twice the frequency per revolution of a two-pole rotor.

### Alternator Output Control

A voltage regulator controls alternator output by changing the amount of current flow through the rotor windings. Any change in rotor winding current changes the strength of the magnetic field acting on the stator windings. In this way, the voltage regulator can maintain a preset charging voltage. The three basic types of voltage regulators are as follows:

- Contact point voltage regulator, mounted away from the alternator in the engine compartment
- Electronic voltage regulator, mounted away from the alternator in the engine compartment
- Electronic voltage regulator, mounted on the back or inside the alternator

The contact point voltage regulator uses a coil, set of points, and resistors that limits system voltage. The electronic or solid-state regulators have replaced this

older type. For operation, refer to the "Regulation of Generator Output" section of this chapter.

The electronic voltage regulators use an electronic circuit to control rotor field strength and alternator output. It is a sealed unit and is not repairable. The electronic circuit must be sealed to prevent damage from moisture, excessive heat, and vibration. A rubberlike gel surrounds the circuit for protection.

An integral voltage regulator is mounted inside or on the rear of the alternator. This is the most common type used on modern vehicles. It is small, efficient, dependable, and composed of integrated circuits.

An electronic voltage regulator performs the same operation as a contact point regulator, except that it uses transistors, diodes, resistors, and capacitors to regulate voltage in the system. To increase alternator output, the electronic voltage regulator allows more current into the rotor windings, thereby strengthen the magnetic field around the rotor. More current is then induced into the stator windings and out of the alternator.

To reduce alternator output, the electronic regulator increases the resistance between the battery and the rotor windings. The magnetic field decreases and less current is induced into the stator windings.

Alternator speed and load determines whether the regulator increases or decreases charging output. If the load is high or rotor speed is low (engine at idle), the regulator senses a drop in system voltage. The regulator then increases the rotors magnetic field current until a preset output voltage is obtained. If the load drops or rotor speed increases, the opposite occurs.

### Alternator Maintenance

Alternator testing and service call for special precautions since the alternator output terminal is connected to the battery at all times. Use care to avoid reversing polarity when performing battery service of any kind. A surge of current in the opposite direction could bum the alternator diodes.

Do not purposely or accidentally "short" or "ground" the system when disconnecting wires or connecting test leads to terminals of the alternator or regulator. For example, grounding of the field terminal at either alternator or regulator will damage the regulator. Grounding of the alternator output terminal will damage the alternator and possibly other portions of the charging system.

Never operate an alternator on an open circuit. With no battery or electrical load in the circuit, alternators are capable of building high voltage (50 to over 110 volts) which may damage diodes and endanger anyone who touches the alternator output terminal.

Alternator maintenance is minimized by the use of prelubricated bearings and longer lasting brushes. If a problem exists in the charging circuit, check for a complete field circuit by placing a large screwdriver on the alternator rear-bearing surface. If the field circuit is complete, there will be a strong magnetic pull on the blade of the screwdriver, which indicates that the field is energized. If there is no field current, the alternator will not charge because it is excited by battery voltage.

Should you suspect troubles within the charging system after checking the wiring connections and battery, connect a voltmeter across the battery terminals. If the voltage reading, with the engine speed increased, is within the manufacturer's recommended specification, the charging system is functioning properly. Should the alternator tests fail, the alternator should be removed for repairs or replacement. Do NOT forget, you must ALWAYS disconnect the cables from the battery first.

### Alternator Testing

To determine what component(s) has caused the problem, you will be required to disassemble and test the alternator.

**ROTOR TESTING.**—To test the rotor for grounds, shorts, and opens, perform the following:

- To check for grounds, connect a test lamp or ohmmeter from one of the slip rings to the rotor shaft (fig. 2-29). A low ohmmeter reading or the

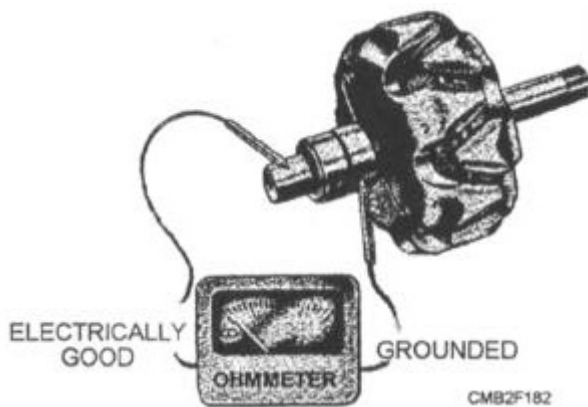

Figure 2-29.—Testing rotor for grounds.

lighting of the test lamp indicates that the rotor winding is grounded.

- To check the rotor for shorts and opens, connect the ohmmeter to both slip rings, as shown in figure 2-30. An ohmmeter reading below the manufacturer's specified resistance value indicates a short. A reading above the specified resistance value indicates an open. If a test lamp does not light when connected to both slip rings, the winding is open.

**STATOR TESTING.**—The stator winding can be tested for opens and grounds after it has been disconnected from the alternator end frame.

If the ohmmeter reading is low or the test lamp lights when connected between each pair of stator leads (fig. 2-31), the stator winding is electrically good.

A high ohmmeter reading or failure of the test lamp to light when connected from any one of the leads to

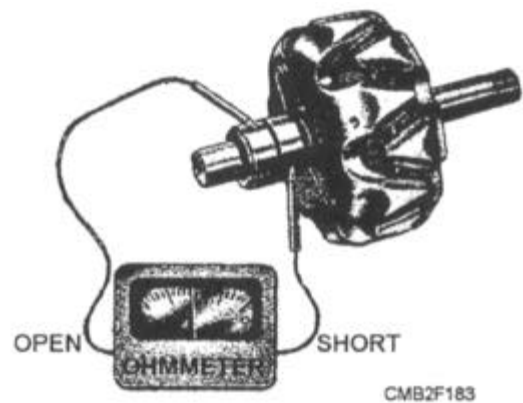

Figure 2-30.—Testing the rotor for opens and shorts.

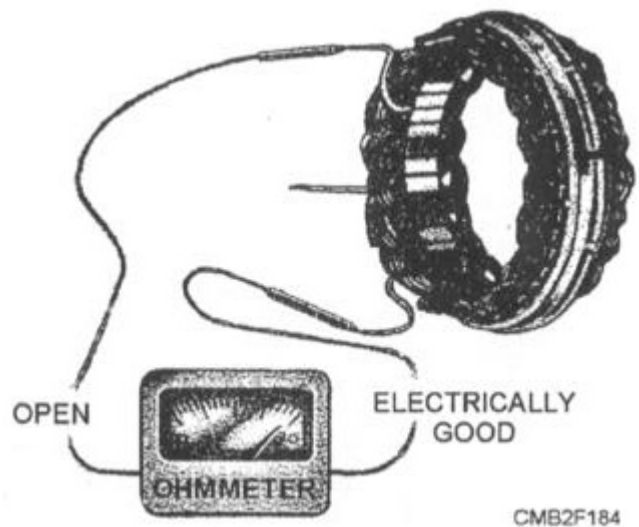

Figure 2-31.—Testing a stator for opens.

the stator frame (fig. 2-32) indicates the windings are not grounded. It is not practical to test the stator for shorts due to the very low resistance of the winding.

**DIODE TESTING.**—With the stator windings disconnected, each diode may be tested with an ohmmeter or with a test light. To perform the test with an ohmmeter, proceed as follows:

- Connect one ohmmeter test lead to the diode lead and the other to the diode case (fig. 2-33). Note the reading. Then reverse the ohmmeter's leads to the diode and again note the reading. If both readings are very low or very high, the diode is defective. A good diode will give one low and one high reading.

An alternate method of testing each diode is to use a test lamp with a 12-volt battery. To perform a test with a test lamp, proceed as follows:

- Connect one of the test leads to the diode lead and the other test lead as shown in figure 2-34. Then reverse the lead connections. If the lamp lights in both checks, the diode is defective. Or, if the lamp fails to light in either direction, the

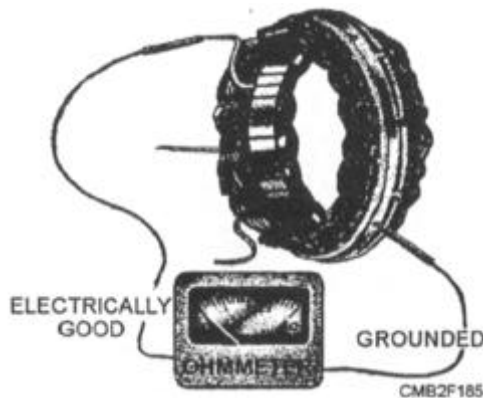

Figure 2-32.—Testing a stator for grounds.

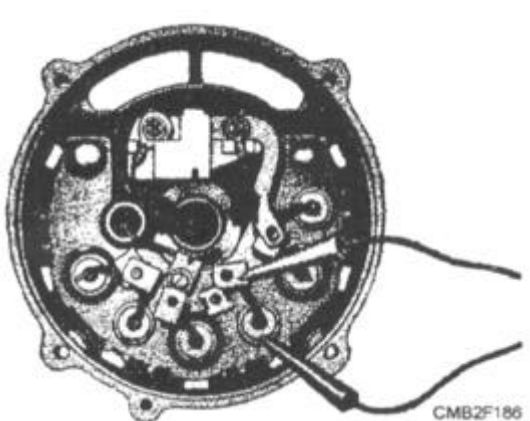

Figure 2-33.—Testing diodes with an ohmmeter.

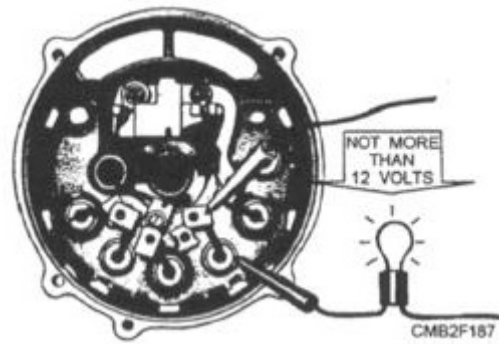

Figure 2-34.—Testing diodes with a test lamp.

diode is defective. When a good diode is being tested, the lamp will light in only one of the two checks.

After completing the required test and making any necessary repairs or replacement of parts, reassemble the alternator and install it on the vehicle. After installation, start the engine and check that the charging system is functioning properly. **NEVER ATTEMPT TO POLARIZE AN ALTERNATOR.** Attempts to do so serves no purpose and may damage the diodes, wiring, and other charging circuit components.

## CHARGING SYSTEM TEST

Charging system tests should be performed when problems point to low alternator voltage and current. These tests will quickly determine the operating condition of the charging system. Common charging system tests are as follows:

- Charging system output test—measures current and voltage output of the charging system.
- Regulator voltage test—measures charging system voltage under low output, low load conditions.
- Regulator bypass test—connects full battery voltage to the alternator field, leaving the regulator out of the circuit.
- Circuit resistance tests—measures resistance in insulated and grounded circuits of the charging system.

Charging system tests are performed in two ways—by using a load tester or by using a volt-ohm-millimeter (VOM/multimeter). The load tester provides the accurate method for testing a charging system by measuring both system current and voltage.

## Charging System Output Test

The charging system output test measures system voltage and current under maximum load. To check output with a load tester, connect tester leads as described by the manufacturer, as you may have either an inductive (clip-on) amp pickup type or a non-inductive type tester. Testing procedures for an inductive type tester are as follows:

- With the load tester controls set as prescribed by the manufacturer, turn the ignition switch to the RUN position. Note the ammeter reading.
- Start the engine and adjust the idle speed to test specifications (approximately 200 rpm).
- Adjust the load control on the tester until the ammeter reads specified current output. Do not let voltage drop below specifications (about 12 volts). Note the ammeter reading.
- Rotate the control knob to the OFF position. Evaluate the readings.

To calculate charging system output, add the two ammeter readings. This will give you total charging system output in amps. Compare this figure to the specifications within the manufacturer's manual.

Current output specifications will depend on the size (rating) of the alternator. A vehicle with few electrical accessories may have an alternator rated at 35 amps, whereas a larger vehicle with more electrical requirements could have an alternator rated from 40 to 80 amps. Always check the manufacturer's service manual for exact values.

If the charging system output current tested low, perform a regulator voltage test and a regulator bypass test to determine whether the alternator, regulator, or circuit wiring is at fault.

## Regulator Voltage Test

A regulator voltage test checks the calibration of the voltage regulator and detects a low or high setting. Most voltage regulators are designed to operate between 13.5 to 14.5 volt range. This range is stated for normal temperatures with the battery fully charged. Regulator voltage test procedure is as follows:

- Set the load tester selector to the correct position using the manufacturer's manual. With the load control OFF, run the engine at 2,000 rpm or specified test speed. Note the voltmeter reading

and compare it to the manufacturer's specifications.

If the voltmeter reading is steady and within manufacturer's specifications, then the regulator setting is okay. However, if the volt reading is steady but too high or too low, then the regulator needs adjustment or replacement. If the reading were not steady, this would indicate a bad wiring connection, an alternator problem, or a defective regulator, and further testing is required.

## Regulator Bypass Test

A regulator bypass test is an easy and quick way of determining if the alternator, regulator, or circuit is faulty. Procedures for the regulator bypass test is similar to the charging system output test, except that the regulator be taken out of the circuit. Direct battery voltage (unregulated voltage) is used to excite the rotor field. This should allow the alternator to produce maximum voltage output.

Depending upon the system there are several ways to bypass the voltage regulator. The most common ways are as follows:

- Sorting a test tab to ground on the rear of the alternator (if equipped).
- Placing a jumper wire across the battery and field terminals of the alternator.
- With a remote regulator, unplug the wire from the regulator and place a jumper wire across the battery and field terminals in the wires to the alternator.

## CAUTION

Follow the manufacturer's directions to avoid damaging the circuit. You must NOT short or connect voltage to the wrong wires or the diodes or voltage regulator may be ruined.

When the regulator bypass test is being performed, charging voltage and current INCREASE to normal levels. This indicates a bad regulator. If the charging voltage and current REMAINS THE SAME, then you have a bad alternator.

## Circuit Resistance Test

A circuit resistance test is used to locate faulty wiring, loose connections, partially burnt wire, corroded terminals, or other similar types of problems.

There are two common circuit resistance tests—insulated resistance test and ground circuit resistance test.

**INSULATED RESISTANCE TEST.**—To perform an insulated resistance test, connect the load tester as described by the manufacturer. A typical connection setup is shown in figure 2-35. Note how the voltmeter is connected across the alternator output terminal and positive battery terminal.

With the vehicle running at a fast idle, rotate the load control knob to obtain a 20-amp current flow at 15 volts or less. All accessories and lights are to be turned OFF. Read the voltmeter. The voltmeter should NOT read over 0.7-volt drop (0.1 volt per electrical connection) for the circuit to be considered in good condition. However, if the voltage drop is over 0.7 volt, circuit resistance is high and a poor electrical connection exists.

**GROUND CIRCUIT RESISTANCE TEST.**—With the ground circuit resistance test the voltmeter leads are placed across the negative battery terminal and alternator housing (fig. 2-36).

The voltmeter should NOT read over 0.1 volt per electrical connection. If the reading is higher, this indicates such problems as loose or faulty connections, burnt plug sockets, or other similar malfunctions.

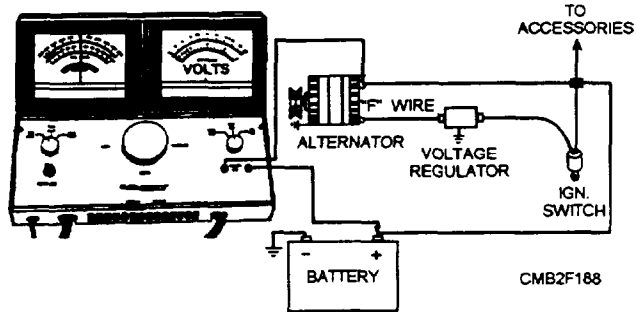

Figure 2-35.—Typical insulated resistance test setup.

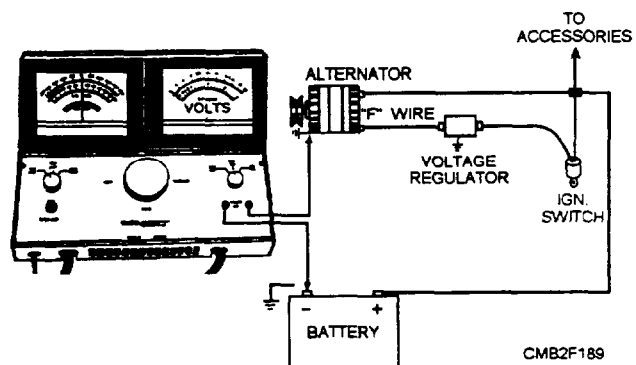

Figure 2-36.—Typical ground circuit resistance test setup.

## REVIEW 1 QUESTIONS

- Q1. How many electrical circuits are in a typical automotive electrical system?
- Q2. What component of the charging system produces and stores electricity?
- Q3. What substance is contained in a positive plate of a fully charged battery?
- Q4. What type of gas collects at the top of a battery?
- Q5. What is the specific gravity of a fully charged battery?
- Q6. What are the two methods of rating lead-acid storage batteries?
- Q7. When mixing electrolyte, you should follow what rule?
- Q8. What battery test will determine if current is discharging across the top of the battery?
- Q9. You are performing a battery drain test using an ammeter. What should the meter read with everything in the vehicle turned off?
- Q10. When performing a quick charge test, you should charge the battery at 30 to 40 amps for what minimum time period?
- Q11. What are the two types of field circuits used in dc generators?
- Q12. What are the three design factors that determine the output of a dc generator?
- Q13. What two tests are used for locating shorts in the armature of a dc generator?
- Q14. What component of the alternator contains the heat sink the diodes, the diode plate, and the electrical terminals?
- Q15. What type of alternator stator is used in high output alternators?
- Q16. How is alternator output reduced using an electronic voltage regulator?
- Q17. What is the most common type of voltage regulator used on modern vehicles?
- Q18. What charging system test measures the charging systems voltage, under low output, low load conditions?
- Q19. What two testing devices are used to perform a charging system test?

Q20. When a regulator bypass test is being performed, what type of voltage is used to excite the rotor field?

### STARTING CIRCUIT

**Learning Objective:** Identify starting-circuit components, their function, operation, and maintenance procedures.

The internal combustion engine is not capable of self-starting. Automotive engines (both spark-ignition and diesel) are cranked by a small but powerful electric motor. This motor is called a cranking motor, starting motor, or starter.

The battery sends current to the starter when the operator turns the ignition switch to start. This causes a pinion gear in the starter to mesh with the teeth of the ring gear, thereby rotating the engine crankshaft for starting.

The typical starting circuit consists of the battery, the starter motor and drive mechanism, the ignition switch, the starter relay or solenoid, a neutral safety switch (automatic transmissions), and the wiring to connect these components.

### STARTER MOTOR

The starting motor (fig. 2-37) converts electrical energy from the battery into mechanical or rotating energy to crank the engine. The main difference between an electric starting motor and an electric generator is that in a generator, rotation of the armature in a magnetic field produces voltage. In a motor, current is sent through the armature and the field; the attraction and repulsion between the magnetic poles of the field and armature coil alternately push and pull the armature around. This rotation (mechanical energy), when properly connected to the flywheel of an engine, causes the engine crankshaft to turn.

#### Starting Motor Construction

The construction of the all starting motors is very similar. There are, however, slight design variations. The main parts of a starting motor are as follows:

- **ARMATURE ASSEMBLY**—The windings, core, starter shaft, and commutator assembly that spin inside a stationary field.
- **COMMUTATOR END FRAME**—The end housing for the brushes, brush springs, and shaft bushings.

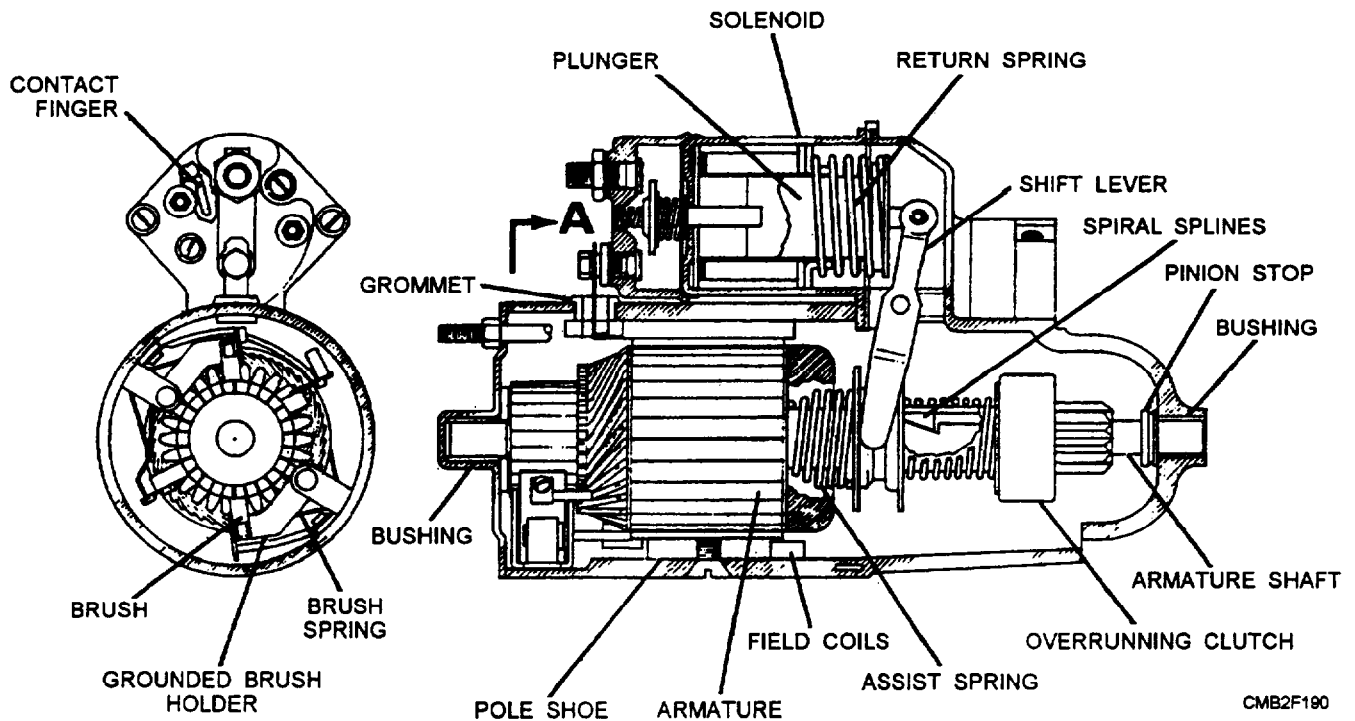

Figure 2-37.—Typical starting motor.

- **PINION DRIVE ASSEMBLY**—The pinion gear, pinion drive mechanism, and solenoid.
- **FIELD FRAME**—The center housing that holds the field coils and pole shoes.
- **DRIVE END FRAME**—The end housing around the pinion gear, which has a bushing for the armature shaft.

**ARMATURE ASSEMBLY.**—The armature assembly consists of an armature shaft, armature core, commutator, and armature windings.

The armature shaft supports the armature assembly as it spins inside the starter housing. The armature core is made of iron and holds the armature windings in place. The iron increases the magnetic field strength of the windings.

The commutator serves as a sliding electrical connection between the motor windings and the brushes and is mounted on one end of the armature shaft. The commutator has many segments that are insulated from each other. As the windings rotate away from the pole shoe (piece), the commutator segments change the electrical connection between the brushes and the windings. This action reverses the magnetic field around the windings. The constant changing electrical connection at the windings keeps the motor spinning.

**COMMUTATOR END FRAME.**—The commutator end frame houses the brushes, the brush springs, and the armature shaft bushing.

The brushes ride on top of the commutator. They slide on the commutator to carry battery current to the spinning windings. The springs force the brushes to maintain contact with the commutator as it spins, thereby no power interruptions occurs. The armature shaft bushing supports the commutator end of the armature shaft.

**PINION DRIVE ASSEMBLY.**—The pinion drive assembly includes the pinion gear, the pinion drive mechanism, and solenoid. There are two ways that a starting motor can engage the pinion assembly—(1) with a moveable pole shoe that engages the pinion gear and (2) with a solenoid and shift fork that engages the pinion gear.

The pinion gear is a small gear on the armature shaft that engages the ring gear on the flywheel. Most starter pinion gears are made as part of a pinion drive mechanism. The pinion drive mechanism slides over one end of the starter armature shaft. The pinion drive mechanism found on starting motors that you will

encounter are of three designs—Bendix drive, overrunning clutch, and Dyer drive.

The **BENDIX DRIVE** (fig. 2-38) relies on the principle of inertia to cause the pinion gear to mesh with the ring gear. When the starting motor is not operating, the pinion gear is out of mesh and entirely away from the ring gear. When the ignition switch is engaged, the total battery voltage is applied to the starting motor, and the armature immediately starts to rotate at high speed.

The pinion, being weighted on one side and having internal screw threads, does not rotate immediately with the shaft but because of inertia, runs forward on the revolving threaded sleeve until it engages with the ring gear. If the teeth of the pinion and ring gear do not engage, the drive spring allows the pinion to revolve and forces the pinion to mesh with the ring gear. When the pinion gear is engaged fully with the ring gear, the pinion is then driven by the starter through the compressed drive spring and cranks the engine. The drive spring acts as a cushion while the engine is being cranked against compression. It also breaks the severity of the shock on the teeth when the gears engage and when the engine kicks back due to ignition. When the engine starts and runs on its own power, the ring gear drives the pinion at a higher speed than does the starter. This action causes the pinion to turn in the opposite direction on the threaded sleeve and automatically disengages from the ring gear. This prevents the engine from driving the starter.

The **OVERRUNNING CLUTCH** (fig. 2-39) provides positive meshing and demeshing of the starter motor pinion gear and the ring gear. The starting motor armature shaft drives the shell and sleeve assembly of the clutch. The rotor assembly is connected to the pinion gear which meshes with the engine ring gear. Spring-loaded steel rollers are located in tapered notches between the shell and the rotor. The springs

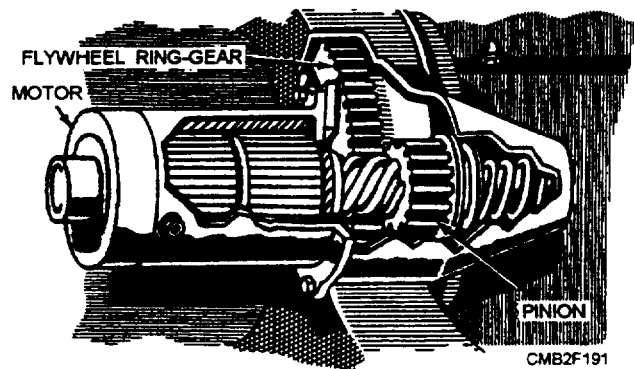

Figure 2-38.—Starting motor with a Bendix drive.



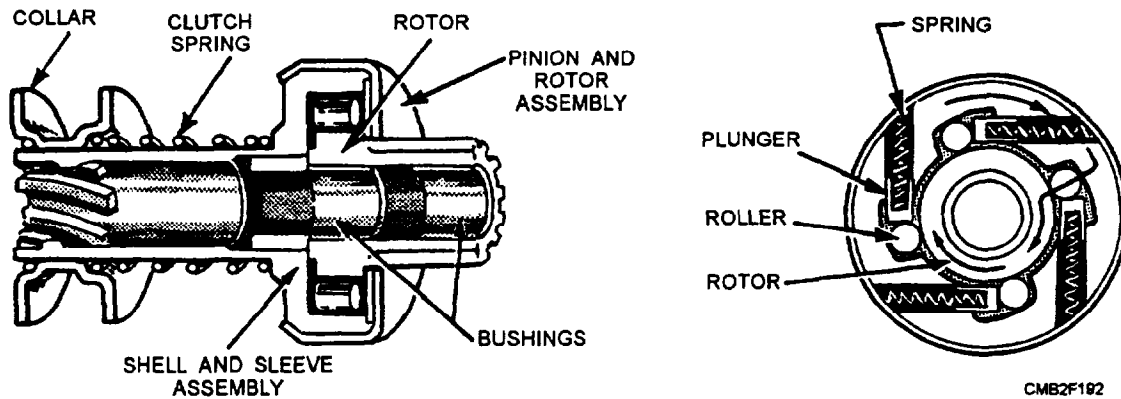

Figure 2-39.—Typical overrunning clutch.

and plungers hold the rollers in position in the tapered notches. When the armature shaft turns, the rollers are jammed between the notched surfaces, forcing the inner and outer members of the assembly to rotate as a unit and crank the engine.

After the engine is started, the ring gear rotates faster than the pinion gear, thus tending to work the rollers back against the plungers, and thereby causing an overrunning action. This action prevents excessive speed of the starting motor. When the starting motor is released, the collar and spring assembly pulls the pinion out of mesh with the ring gear.

The DYER DRIVE (fig. 2-40) provides complete and positive meshing of the drive pinion and ring gear before the starting motor is energized. It combines

principles of both the Bendix and overrunning clutch drives and is commonly used on heavy-duty engines.

A starter solenoid is used to make the electrical connection between the battery and the starting motor. The starter solenoid is an electromagnetic switch; it is similar to other relays but is capable of handling higher current levels. A starter solenoid, depending on the design of the starting motor, has the following functions:

- Closes battery-to-starter circuit.
- Rushes the starter pinion gear into mesh with the ring gear.
- Bypass resistance wire in the ignition circuit.

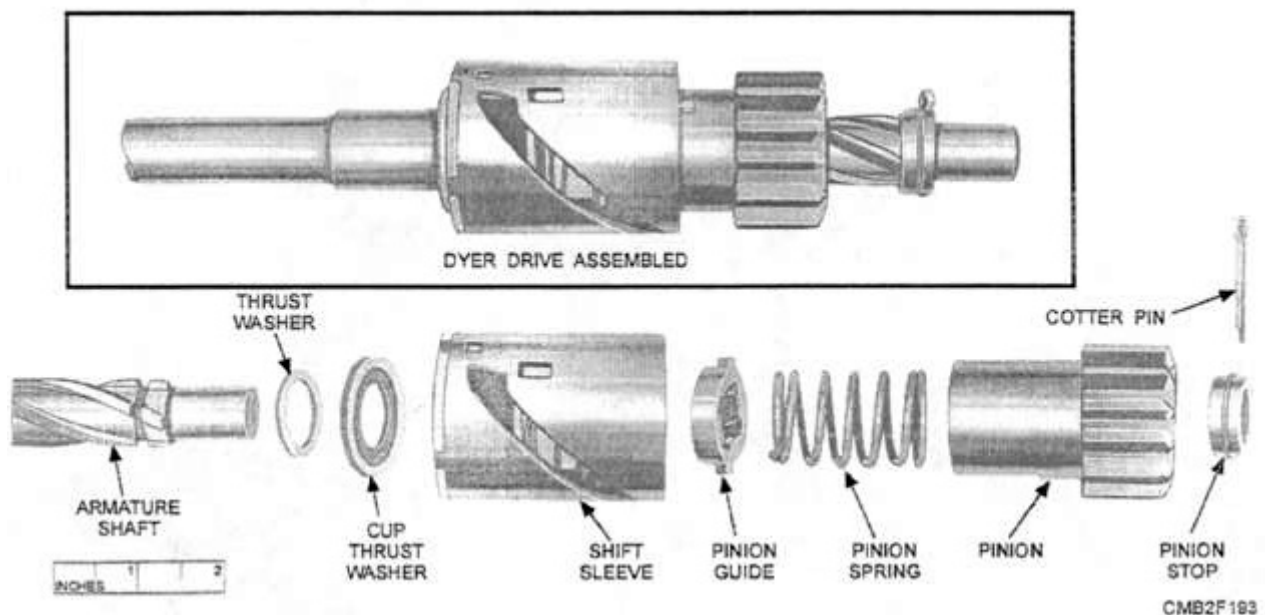

Figure 2-40.—Dyer drive.

The starter solenoid may be located away from or on the starting motor. When mounted away from the starter, the solenoid only makes and breaks electrical connection. When mounted on the starter, it also slides the pinion gear into the flywheel.

In operation, the solenoid is actuated when the ignition switch is turned or when the starter button is depressed. The action causes current to flow through the solenoid (causing a magnetic attraction of the plunger) to ground. The movement of the plunger causes the shift lever to engage the pinion with the ring gear. After the pinion is engaged, further travel of the plunger causes the contacts inside the solenoid to close and directly connects the battery to the starter.

If cranking continues after the control circuit is broken, it is most likely to be caused by either shorted solenoid windings or by binding of the plunger in the solenoid. Low voltage from the battery is often the cause of the starter making a clicking sound. When this occurs, check all starting circuit connections for cleanliness and tightness.

**FIELD FRAME.**—The field frame is the center housing that holds the field coils and pole shoes.

The field coil (winding) is a stationary set of windings that creates a strong magnetic field around the motor armature. When current flows through the winding, the magnetic field between the pole shoes becomes very large. Acting against the magnetic field created by the armature, this action spins the motor with extra power. Field windings vary according to the application of the starter motor. The most popular configurations are as follows (fig. 2-41):

- **TWO WINDINGS, PARALLEL**—The wiring of the two field coils in parallel will increase their strength because they receive full voltage. Note that two additional pole shoes are used. Though they have no windings, their presence will further strengthen the magnetic field.
- **FOUR WINDINGS, SERIES-PARALLEL**—The wiring of four field coils in a series-parallel combination creates a stronger magnetic field than the two field coil configuration.
- **FOUR WINDINGS, SERIES**—The wiring of four field coils in series provides a large amount of low-speed torque, which is desirable for automotive starting motors. However, series-wound motors can build up excessive speed if

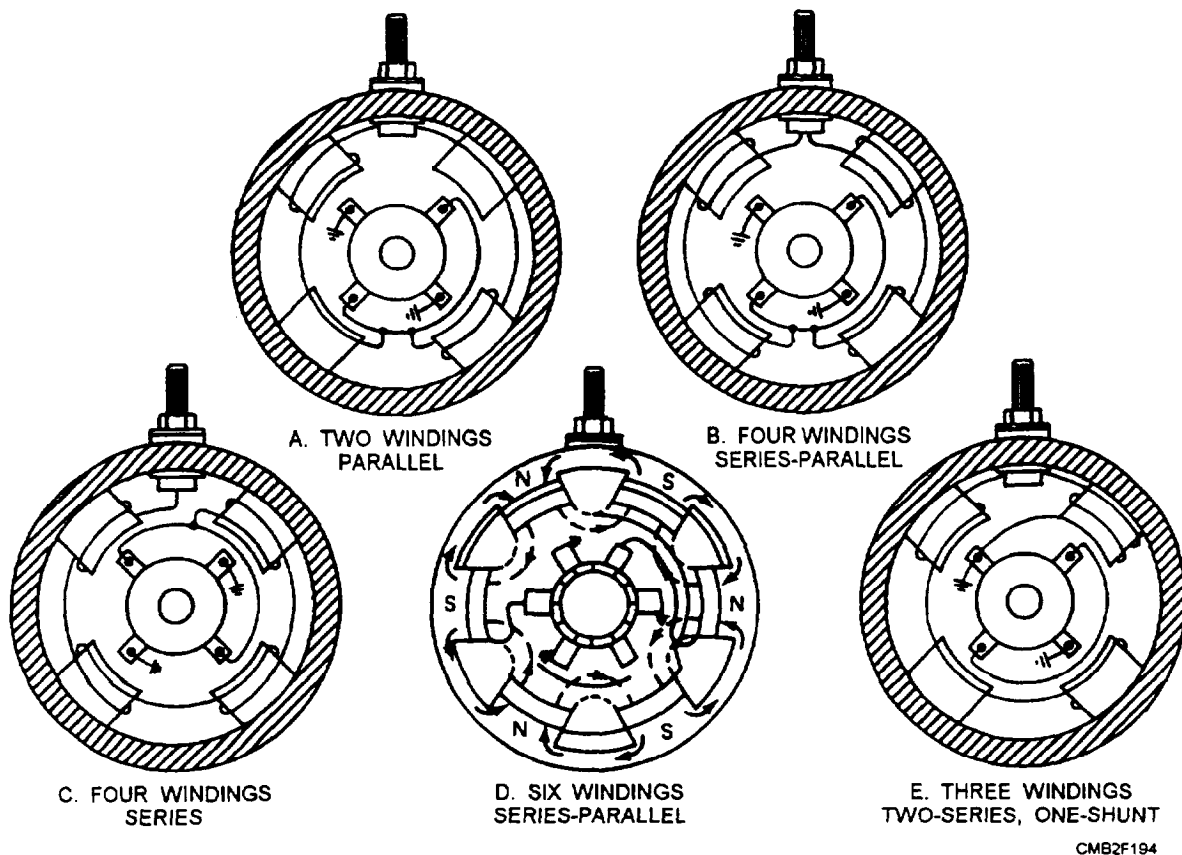

Figure 2-41.—Field winding configurations.

allowed to run free to the point where they will destroy themselves.

- **SIX WINDINGS, SERIES-PARALLEL**—Three pairs of series-wound field coils provide the magnetic field for a heavy-duty starter motor. This configuration uses six brushes.
- **THREE WINDINGS, TWO SERIES, ONE SHUNT**—The use of one filled coil that is shunted to ground with a series-wound motor controls motor speed. Because the shunt coil is not affected by speed, it will draw a steady heavy current, effectively limiting speed.

**DRIVE END FRAME.**—The drive end frame is designed to protect the drive pinion from damage and to support the armature shaft. The drive end frame of the starter contains a bushing to prevent wear between the armature shaft and drive end frame.

### Types of Starting Motors

There are two types of starting motors that you will encounter on equipment. These are the direct drive starter and the double reduction starter. All starters require the use of gear reduction to provide the mechanical advantage required to turn the engine flywheel and crankshaft.

**DIRECT DRIVE STARTERS.**—Direct drive starters make use of a pinion gear on the armature shaft of the starting motor. This gear meshes with teeth on the ring gear. There are between 10 to 16 teeth on the ring gear for every one on the pinion gear. Therefore, the starting motor revolves 10 to 16 times for every revolution of the ring gear. In operation, the starting motor armature revolves at a rate of 2,000 to 3,000 revolutions per minute, thus turning the engine crankshaft at speeds up to 200 revolutions per minute.

**DOUBLE REDUCTION STARTER.**—The double reduction starter makes use of gear reduction within the starter and the reduction between the drive pinion and the ring gear. The gear reduction drive head is used on heavy-duty equipment.

Figure 2-42 shows a typical gear reduction starter. The gear on the armature shaft does not mesh directly with the teeth on the ring gear, but with an intermediate gear which drives the driving pinion. This action provides additional breakaway, or starting torque, and greater cranking power. The armature of a starting motor with a gear reduction drive head may rotate as many as 40 revolutions for every revolution of the engine flywheel.

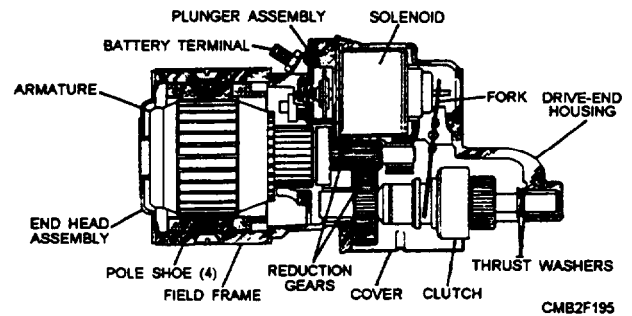

Figure 2-42.—Gear reduction starter.

### NEUTRAL SAFETY SWITCH

Vehicles equipped with automatic transmissions require the use of a neutral safety switch. The neutral safety switch prevents the engine from being started unless the shift selector of the transmission is in NEUTRAL or PARK. It disables the starting circuit when the transmission is in gear. This safety feature prevents the accidental starting of a vehicle in gear, which can result in personal injury and vehicle damage.

The neutral safety switch is wired into the circuit going to the starter solenoid. When the transmission is in forward or reverse gear, the switch is in the OPEN position (disconnected). This action prevents current from activating the solenoid and starter when the ignition switch is turned to the START position. When the transmission is in neutral or park, the switch is closed (connected), allowing current to flow to the starter when the ignition is turned.

A misadjusted or bad neutral safety switch can keep the engine from cranking. If the vehicle does not start, you should check the action of the neutral safety switch by moving the shift lever into various positions while trying to start the vehicle. If the starter begins to work, the switch needs to be readjusted.

To readjust a neutral safety switch, loosen the fasteners that hold the switch. With the switch loosened, place the shift lever into park (P). Then, while holding the ignition switch in the START position, slide the neutral switch on its mount until the engine cranks. Without moving the switch, tighten the fasteners. The engine should now start with the shift lever in park or neutral. Check for proper operation after the adjustment.

If by adjusting the switch to normal operation is not resumed, it may be required to test the switch. All that is required to test the switch is a 12-volt test light.

To test the switch, touch the test light to the switch output wire connection while moving the shift lever. The light should glow as the shift lever is slid into park or neutral. The light should not work in any other position. If the light is not working properly, check the mechanism that operates the switch. If the problem is in the switch, replace it.

## **STARTING CIRCUIT MAINTENANCE**

The condition of the starting motor should be carefully checked at each PM service. This permits you to take appropriate action, where needed, so equipment failures caused by a faulty starter can be reduced, if not eliminated.

A visual inspection for clean, tight electrical connections and secure mounting at the flywheel housing is the extent of the maintenance check. Then operate the starter and observe the speed of rotation and the steadiness of operation. To prevent the starter from overheating, do NOT operate the starter for more than 30 seconds.

If the starter is not operating properly, remove the starter, disassemble it, and check the commutator and brushes. If the commutator is dirty, it may be cleaned with a piece of No. 00 sandpaper. However, if the commutator is rough, pitted, or out-of-round or if the insulation between the commutator bars is high, it must be reconditioned using an armature lathe.

Brushes should be at least half of their original size. If not, replace them. The brushes should have free movement in the brush holders and make good, clean contact with the commutator.

Once the starter is checked and repaired as needed, it should be reassembled, making sure that the starter brushes are seated. Align the housings and install the bolts securely. Install the starter in the opening in the flywheel housing and tighten the attaching bolts to the specified torque. Connect the cable and wire lead firmly to clean terminals.

## **STARTING MOTOR CIRCUIT TESTS**

There are many ways of testing a starting motor circuit to determine its operating condition. The most common tests are as follows:

- The starter current draw test is used to measure the amount of amperage used by the starting circuit.

- The starter circuit voltage drop tests (insulated circuit resistance test and starter ground test) are used to locate parts with higher than normal resistance quickly.

### **Starter Current Draw Test**

The starter current draw test measures the amount of amperage used by the starting circuit. It quickly tells you about the condition of the starting motor and other circuit components. If the current draw is lower or higher than the manufacturer's specifications, there is a problem in the circuit.

To perform a starter current draw test, you may use either a voltmeter or inductive ammeter or a battery load tester. These meters are connected to the battery to measure battery voltage and current flow out of the battery. For setup procedures, use the manufacturer's manual for the type of meter you intend to use.

To keep a gasoline engine from starting during testing, disconnect the coil supply wire or ground the coil wire. With a diesel engine, disable the fuel injection system or unhook the fuel shutoff solenoid. Check the manufacturer's service manual for details.

With the engine ready for testing, crank the engine and note the voltage and current readings. Check the manufacturer's service manual. If they are not within specifications, there is something wrong with the starting circuit.

### **WARNING**

Do NOT crank the engine for more than 30 seconds or starter damage can result. If the starter is cranked too long, it will overheat. Allow the starter to cool for a few minutes if more cranking time is needed.

### **Starting Circuit Voltage Drop Tests**

A voltage drop test will quickly locate a component with higher than normal resistance. This test provides an easy way of checking circuit condition. You do NOT have to disconnect any wires and components to check for voltage drops. The two types of voltage drop tests are the insulated circuit resistance test and the starter ground circuit test.

**INSULATED CIRCUIT RESISTANCE TEST.**—The insulated circuit resistance test checks all components between the positive terminal of the battery and the starting motor for excess resistance.

Using a voltmeter, connect the leads to the positive terminal of the battery and the starting motor output terminal.

With the ignition or injection system disabled, crank the engine. Note the voltmeter reading. It should not be over 0.5 volts. If voltage drop is greater, something within the circuit has excessive resistance. There may be a burned or pitted solenoid contact, loose electrical connections, or other malfunctions. Each component is then to be tested individually.

**STARTER GROUND CIRCUIT TEST.**—The starter ground circuit test checks the circuit between the starting motor and the negative terminal of the battery.

Using a voltmeter, connect the leads to the negative terminal of the battery and to the end frame of the starting motor. Crank the engine and note the voltmeter reading. If it is higher than 0.5 volts, check the voltage drop across the negative battery cable. The engine may not be properly grounded. Clean, tighten, or replace the battery cable if needed. A battery cable problem can produce symptoms similar to a dead battery, bad solenoid, or weak starting motor. If the cables do NOT allow enough current to flow, the starter will turn slowly or not at all.

## REVIEW 2 QUESTIONS

- Q1. *What are the three types of pinion drive mechanisms used on starting motors?*
- Q2. *What is the only function of a starter solenoid when it is mounted away from the starter?*
- Q3. *What is the most likely cause of a starter making a clicking sound?*
- Q4. *What type of starter uses gear reduction within the starter and gear reduction between the drive pinion and the ring gear?*
- Q5. *When repairing a starter, you should replace the brushes if they are one half of their original size. (T/F)*
- Q6. *When a starter is being tested what is the maximum amount of time the engine should be cranked before starter damage can occur?*
- Q7. *What test is used to check for excessive resistance in all components between the positive battery terminal and the starter?*

## IGNITION CIRCUIT

**Learning Objective:** Identify ignition-circuit components, their functions, and maintenance procedures.

The ignition circuit supplies high voltage surges (some as high as 50,000 volts in electronic ignition circuits) to the spark plugs in the engine cylinders. These surges produce electric sparks across the spark plug gaps. The heat from the spark ignites the compressed air-fuel mixture in the combustion chambers. When the engine is idling, the spark appears at the spark plug gap just as the piston nears top dead center (TDC) on the compression stroke. When the engine is operating at higher speeds, the spark is advanced. It is moved ahead and occurs earlier in the compression stroke. This design gives the compressed mixture more time to bum and deliver its energy to the pistons.

The functions of an ignition circuit are as follows:

- Provide a method of turning the ignition circuit ON and OFF.
- Be capable of operating on various supply voltages (battery or alternator voltage).
- Produce a high voltage arc at the spark plug electrodes to start combustion.
- Distribute high voltage pulses to each spark plug in the correct sequence.
- Time the spark so that it occurs as the piston nears TDC on the compression stroke.
- Vary spark timing with engine speed, load, and other conditions.

## PRIMARY AND SECONDARY CIRCUITS

The ignition circuit is actually made of two separate circuits which work together to cause the electric spark at the spark plugs. These two circuits are the PRIMARY and SECONDARY.

The primary circuit of the ignition circuit includes all of the components and wiring operating on low voltage (battery or alternator voltage). Wiring in the primary circuit uses conventional wire, similar to the wire used in other electrical circuits on the vehicle.

The secondary circuit of the ignition circuit is the high voltage section. It consists of the wire and components between the coil output and the spark plug ground. Wiring in the secondary circuit must have a thicker insulation than that of the primary circuit to prevent leaking (arcing) of the high voltage.

## IGNITION CIRCUIT COMPONENTS

Various ignition circuit components are designed to achieve the functions of the ignition circuit. Basic ignition circuit components are as follows:

- **BATTERY**—provides power for the circuit. (This was discussed earlier in this chapter.)
- **IGNITION SWITCH**—allows the operator to turn the circuit and engine ON and OFF.
- **IGNITION COIL**—changes battery voltage to high ignition voltage (30,000 volts and greater).
- **IGNITION DISTRIBUTOR**—distributes ignition voltage to the spark plug. Contains either mechanical contact points or an electronic switching circuit.
- **SPARK PLUG**—device that provides an air gap in the combustion chamber for an electric arc.

### Ignition Switch

The ignition switch (fig. 2-43) enables the operator to turn the ignition on for starting and running the engine and to turn it off to stop the engine. Most automotive ignition switches incorporate four positions, which are as follows:

**OFF.**—The OFF position shuts off the electrical system. Systems, such as the headlights, are usually not wired through the ignition switch and will continue to operate.

**ACCESSORY.**—The ACCESSORY position turns on power to the entire vehicle electrical system with the exception of the ignition circuit.

**IGNITION ON.**—The IGNITION-ON position turns on the entire electrical system including the ignition circuit.

**START.**—The START position will energize the starter solenoid circuit to crank the engine. The START position is spring-loaded to return to the

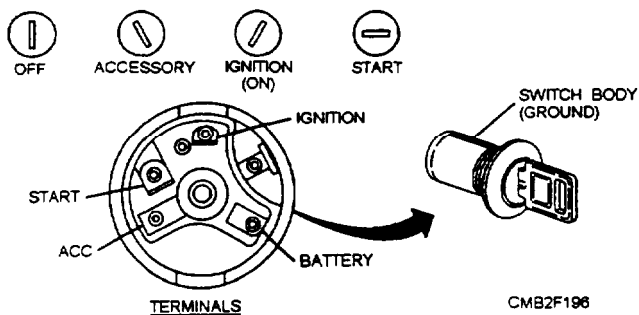

Figure 2-43.—Ignition switch and positions.

IGNITION-ON position when the key is released automatically.

### Ignition Coil

The ignition coil (fig. 2-44) produces the high voltage required to make current jump the gap at the spark plugs. It is a pulse type transformer capable of producing a short burst of high voltage for starting combustion.

The ignition coil is made of two sets of windings (primary and secondary), two primary terminals (low voltage connections), an iron core (long piece of iron inside the windings), and a high voltage terminal (coil wire connection).

The primary winding is the outer winding and is made up of several hundred turns of heavy wire, wrapped around or near the secondary winding. The secondary winding is the inner winding and is made up of several thousand turns of heavy wire located inside or near the primary winding. The secondary windings are wound in the opposite direction of the primary, and the ends are attached internally to the primary windings and the high voltage terminal. Both windings are wrapped around an iron core and are housed inside the coil case.

To obtain the high current required for ignition, battery current flows through the ignition coil primary windings producing a strong magnetic field. The action of the iron core strengthens the magnetic field.

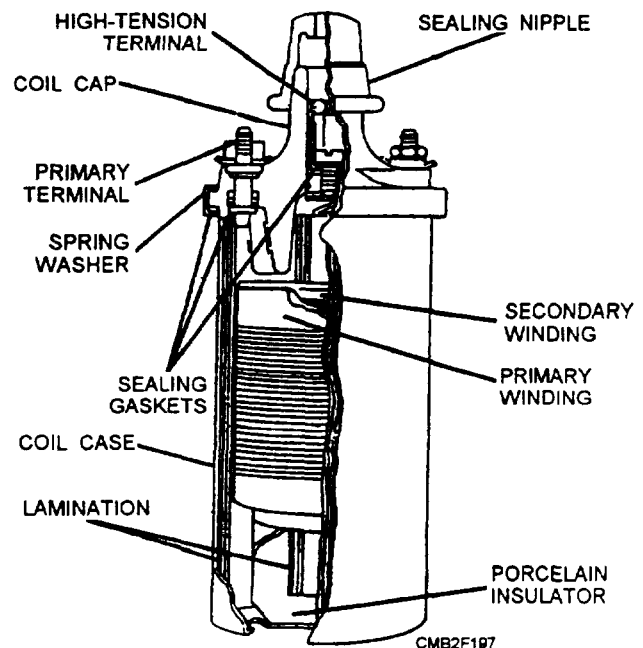

Figure 2-44.—Sectional view of an ignition coil.

When the current flowing through the coil is broken (the primary circuit is opened), the magnetic field collapses across the secondary windings. As the magnetic field collapses, a high electrical voltage is induced into the secondary circuit.

Since both the primary and secondary windings of the coil are stationary, some means other than movement of the windings must be found to change the magnetic field surrounding the coils. In practice, a switching device in the primary circuit creates this effect. There are two common methods to break current flow and fire the coil—mechanical contact points or an electronic switching device.

## Ignition Distributor

An ignition distributor can be a contact point or pickup coil type, as shown in figure 2-45. A contact point distributor is commonly found in older vehicles,

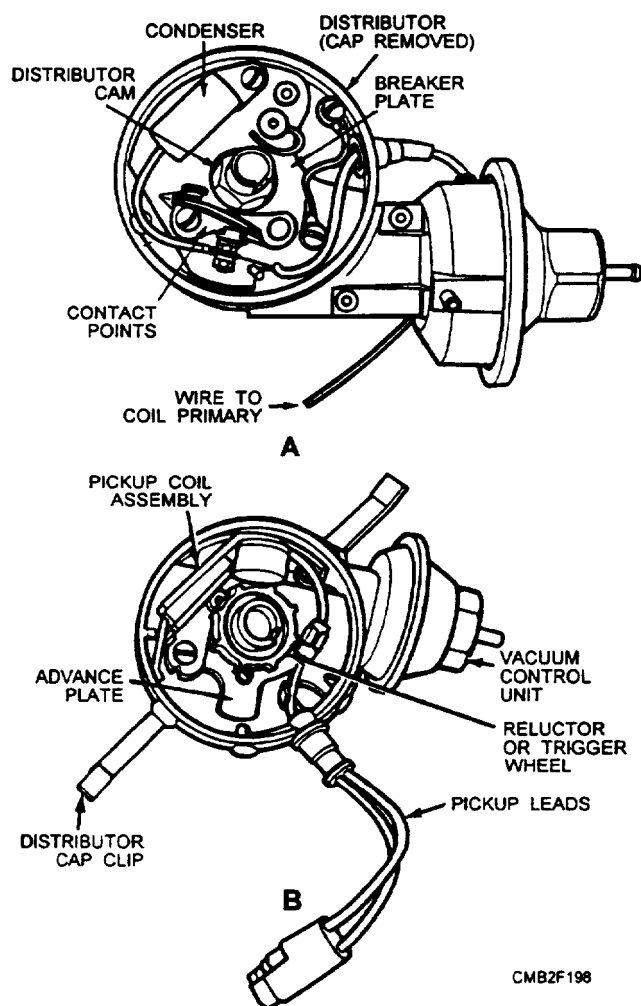

Figure 2-45.—Comparison of a (A) contact point distributor and a (B) pickup coil distributor.

whereas the pickup coil type distributor is used on many modern vehicles. The ignition distributor has several functions, which are as follows:

- It actuates the ON/OFF cycles of current flow through the primary windings of the coil.
- It distributes the high voltage surges of the coil to the spark plugs.
- It causes the spark to occur at each spark plug earlier in the compression stroke as speed increases.
- It changes spark timing with the changes in engine load. As more load is placed on the engine, the spark timing must occur later in the compression stroke to prevent spark knock.
- In some cases, the bottom of the distributor shaft powers the engine oil pump.
- In some electronic distributors, the distributors house the ignition coil and the electronic switching unit.

**DISTRIBUTOR CAP.**—The distributor cap is an insulating plastic component that covers the top of the distributor housing. Its center terminal transfers voltage from the coil wire to the rotor. The distributor cap also has outer terminals that send electric arcs to the spark plugs. Metal terminals are molded into the plastic cap to provide electrical connections.

**DISTRIBUTOR ROTOR.**—The distributor rotor transfers voltage from the coil wire to the spark plug wires. The rotor is mounted on top of the distributor shaft. It is an electrical switch that feeds voltage to each spark plug wire in turn.

A metal terminal on the rotor touches the distributor cap center terminal. The outer end of the rotor ALMOST touches the outer cap terminals. Voltage is high enough that it can jump the air space between the rotor and cap. Approximately 4,000 volts are required for the spark to jump this rotor-to-cap gap.

## SPARK PLUG

The spark plug consists of a porcelain insulator in which there is an insulated electrode supported by a metal shell with a grounded electrode. They have a simple purpose of supplying a fixed gap in the cylinder across which the high voltage surges from the coil must jump after passing through the distributor.

The spark plugs use ignition coil high voltage to ignite the fuel mixture. Somewhere between 4,000 and 10,000 volts are required to make current jump the gap

at the plug electrodes. This is much lower than the output potential of the coil.

Spark plug gap is the distance between the center and side electrodes. Normal gap specifications range between .030 to .060 inch. Smaller spark plug gaps are used on older vehicles equipped with contact point ignition systems.

Spark plugs are either resistor or non-resistor types (fig. 2-46). A resistor spark plug has internal resistance (approximately 10,000 ohms) designed to reduce the static in radios. Most new vehicles require resistor type plugs. Non-resistor spark plug has a solid metal rod forming the center electrode. This type of spark plug is NOT commonly used except for racing and off-road vehicles.

### Spark Plug Heat Range and Reach

The heat range of the spark plug determines how hot the plug will get. The length and diameter of the insulator tip and the ability of the spark plug to transfer heat into the cooling system determine spark plug heat range.

A hot spark plug has a long insulator tip that prevents heat transfer into the waterjackets. It will also bum off any oil deposits. This provides a self-cleaning action.

A cold spark plug has a shorter insulator tip and operates at a cooler temperature. The cooler tip helps

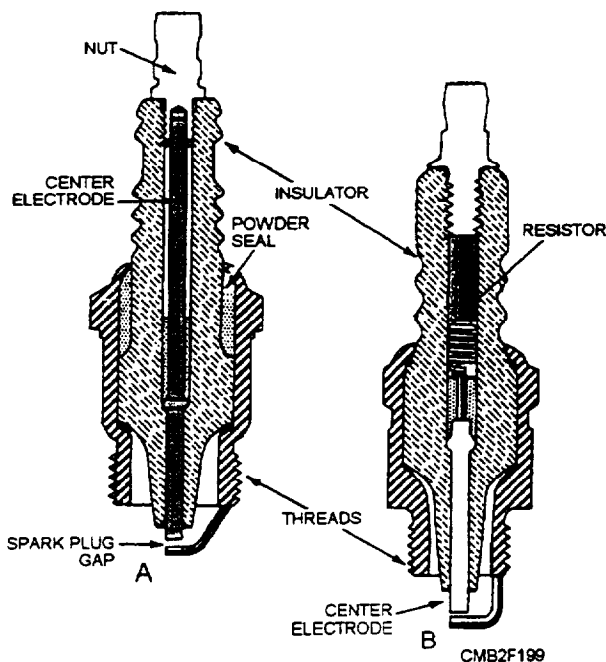

Figure 2-46.—Sectional view of a (A) non-resistor and (B) resistor spark plug.

prevent overheating and preignition. A cold spark plug is used in engines operated at high speeds.

Vehicle manufacturers recommend a specific spark plug heat range for their engines. The heat range is coded and given as a number on the spark plug insulator. The larger the number on the plug, the hotter the spark plug tip will operate. For example, a 54 plug would be hotter than a 44 or 34 plug.

The only time you should change from spark plug heat range specifications is when abnormal engine or operating conditions are encountered. For instance, if the plug runs too cool, sooty carbon will deposit on the insulator around the center electrode. This deposit could soon build up enough to short out the plug. Then high voltage surges would leak across the carbon instead of producing a spark across the spark plug gap. Using a hotter plug will bum this carbon deposit away or prevent it from forming.

Spark plug reach is the distance between the end of the spark plug threads and the seat or sealing surface of the plug. Plug reach determines how far the plug reaches through the cylinder head. If spark plug reach is too long, the spark plug will protrude too far into the combustion chamber and the piston at TDC may strike the electrode. However, if the reach is too short, the plug electrode may not extend far enough into the cylinder head and combustion efficiency will be reduced. A spark plug must reach into the combustion chamber far enough so that the spark gap will be properly positioned in the combustion chamber without interfering with the turbulence of the air-fuel mixture or reducing combustion action.

### Spark Plug Wires

The spark plug wires carry the high voltage electric current from the distributor cap side terminals to the spark plugs. In vehicles with distributorless ignition, the spark plug wires carry coil voltage directly to the spark plugs. The two types of spark plug wires are as follows:

- **SOLID WIRE**—Solid wire spark plug wires are used on older vehicles. The wire conductor is simply a strand of metal wire. Solid wires cause radio interference and are no longer used on vehicles.
- **RESISTANCE WIRE**—Resistance spark plug wires consist of carbon-impregnated strands of rayon braid. They are used on modern vehicle because they contain internal resistance that



prevents radio interference. Also known as radio interference wires, they have approximately 10,000 ohms per foot. This prevents high-voltage-induced popping or cracking of the radio speakers.

On the outer ends of the spark plug wires, boots protect the metal connectors from corrosion, oil, and moisture that would permit high voltage to leak across the terminal to the shell of the spark plug.

## **CONTACT POINT IGNITION SYSTEM**

Before studying today's electronic ignition systems, you should have a basic understanding of the contact point ignition system. The two systems use many of the same components. These include the battery, the ignition coil, the ignition distributor, the spark plugs, and wires and cables that connect them.

### **Contact Point Ignitions System Components**

The internal components of the distributor for a contact point ignition consist of the following:

- **DISTRIBUTOR CAM**—The distributor cam is part of, or is attached to, the distributor shaft and has one lobe for each cylinder. As the cam rotates with the shaft at one half of engine speed, the lobes cause the contact points to open and close the primary circuit.
- **CONTACT POINTS**—The contact points, also called breaker points, act like spring-loaded electrical switches in the distributor. Its function is to cause intermittent current flow in the primary circuit, thus causing the magnetic field in the coil to build up and collapse when it reaches maximum strength. Wires from the condenser and ignition coil primary circuit connect to the points.
- **CONDENSER**—The condenser, also known as a capacitor, is wired in parallel with the contact points and grounded through the distributor housing. The condenser prevents arcing or burning at the distributor contact points when the points are first open. The condenser provides a place where current can flow until the contact points are fully open.

### **Contact Point Ignition System Operation**

With the engine running, the distributor shaft and distributor cam rotate. This action causes the distributor cam to open and close the contact points.

With the contact points wired to the primary windings of the ignition coil, the contact points make and break the ignition coil primary circuit. With the contact points closed, the magnetic field builds up in the coil. As the points open, the magnetic field collapses and voltage is sent to the spark plugs.

With the distributor operating at one half of engine speed and with only one cam for each engine cylinder, each spark plug only fires once during a complete revolution of the distributor cam.

To ensure that the contact points are closed for a set time, point dwell, also known as cam angle, is set by using a dwell meter. Point dwell is the amount of time given in degrees of distributor rotation that the points remain closed between each opening.

A dwell period is required to assure that the coil has enough time to build up a strong magnetic field. If the point dwell is too small, the current will have insufficient time to pass through the primary windings of the ignition coil, resulting in a weak spark. However, if the point dwell is too great, the contact points will not open far enough, resulting in arcing or burning of the points.

## **ELECTRONIC IGNITION SYSTEM**

The basic difference between the contact point and the electronic ignition system is in the primary circuit. The primary circuit in a contact point ignition system is open and closed by contact points. In the electronic system, the primary circuit is open and closed by the electronic control unit (ECU).

The secondary circuits are practically the same for the two systems. The difference is that the distributor, ignition coil, and wiring are altered to handle the high voltage produced by the electronic ignition system.

One advantage of this higher voltage (up to 60,000 volts) is that spark plugs with wider gaps can be used. This results in a longer spark, which can ignite leaner air-fuel mixtures. As a result engines can run on leaner mixtures for better fuel economy and lower emissions.

## Electronic Ignition System Components

The components of an electronic ignition system regardless of the manufacturer all perform the same functions. Each manufacturer has its own preferred terminology and location of the components. The basic components of an electronic ignition system are as follows:

- **TRIGGER WHEEL**—The trigger wheel, also known as a reluctor, pole piece, or armature, is connected to the upper end of the distributor shaft. The trigger wheel replaces the distributor cam. Like the distributor cam lobes, the teeth on the trigger wheel equal the number of engine cylinders.
- **PICKUP COIL**—The pickup coil, also known as a sensor assembly, sensor coil, or magnetic pickup assembly, produces tiny voltage surges for the ignition system's electronic control unit. The pickup coil is a small set of windings forming a coil.
- **ELECTRONIC CONTROL UNIT AMPLIFIER**—The ignition system electronic control unit amplifier or control module is an "electronic switch" that turns the ignition coil primary current ON and OFF. The ECU performs the same function as the contact points. The ignition ECU is a network of transistors, capacitors, resistors, and other electronic components sealed in a metal or plastic housing. The ECU can be located (1) in the engine compartment, (2) on the side of the distributor, (3) inside the distributor, or (4) under the vehicle dash. ECU dwell time (number of degrees the circuit conducts current to the ignition coil) is designed into the electronic circuit of the ECU and is NOT adjustable.

## Electronic Ignition System Operation

With the engine running, the trigger wheel rotates inside the distributor. As a tooth of the trigger wheel passes the pickup coil, the magnetic field strengthens around the pickup coil. This action changes the output voltage or current flow through the coil. As a result, an electrical surge is sent to the electronic control unit, as the trigger wheel teeth pass the pickup coil.

The electronic control unit increases the electrical surges into ON/OFF cycles for the ignition coil. When the ECU is ON, current passes through the primary windings of the ignition coil, thereby developing a

magnetic field. Then, when the trigger wheel and pickup coil turn OFF the ECU, the magnetic field inside the ignition coil collapses and fires a sparkplug.

## Hall-Effect Sensor

Some electronic distributors have a magnetic sensor using the Hall effect. When a steel shutter moves between the two poles of a magnet, it cuts off the magnetism between the two poles. The Hall-effect distributor has a rotor with curved plates, called shutters. These shutters are curved so they can pass through the air gap between the two poles of the magnetic sensor, as the rotor turns. Like the trigger wheel, there are the same number of shutters as there are engine cylinders.

Each time a shutter moves through the air gap between the two poles of the magnetic sensor, it cuts off the magnetic field between the poles. This action provides a signal to the ECU. When a shutter is not in the way, the magnetic sensor is producing voltage. This voltage is signaling the ECU to allow current to flow through the ignition coils primary winding. However, when the shutter moves to cut off the magnetic field, the signal voltage drops to zero. The ECU then cuts off the current to the ignition coils primary winding. The magnetic field collapses, causing the coil secondary winding to produce a high voltage surge. This high voltage surge is sent by the rotor to the proper spark plug.

## IGNITION TIMING DEVICES

Ignition timing refers to how early or late the spark plugs fire in relation to the position of the engine pistons. Ignition timing must vary with engine speed, load, and temperature.

Timing advance happens when the spark plugs fire sooner than the compression strokes of the engine. The timing is set several degrees before top dead center (TDC). More time advance is required at higher speeds to give combustion enough time to develop pressure on the power stroke.

Timing retard happens when the spark plugs fire later on the compression strokes. This is the opposite of timing advance. Spark retard is required at lower speeds and under high load conditions. Timing retard prevents the fuel from burning too much on the compression stroke, which would cause spark knock or ping.

The basic methods to control ignition system timing are as follows:

- CENTRIFUGAL ADVANCE (controlled by engine speed)
- VACUUM ADVANCE (controlled by intake manifold vacuum and engine load)
- COMPUTERIZED ADVANCE (controlled by various sensors—speed, temperature, intake, vacuum, throttle position, etc.)

### **Centrifugal Advance**

Centrifugal advance makes the ignition coil and spark plugs fire sooner as engine speed increases, using spring-loaded weights, centrifugal force, and lever action to rotate the distributor cam or trigger wheel. Spark timing is advanced by rotating the distributor cam or trigger wheel against distributor shaft rotation. This action helps correct ignition timing for maximum engine power. Basically the centrifugal advance consists of two advance weights, two springs, and an advance lever.

During periods of low engine speed, the springs hold the advance weights inward towards the distributor cam or trigger wheel. At this time there is not enough centrifugal force to push the weights outward. Timing stays at its normal initial setting.

As speed increases, centrifugal force on the weights moves them outwards against spring tension. This movement causes the distributor cam or trigger wheel to move ahead. With this design, the higher the engine speed, the faster the distributor shaft turns, the farther out the advance weights move, and the farther ahead the cam or trigger wheel is moved forward or advanced. At a preset engine speed, the lever strikes a stop and centrifugal advance reaches maximum.

The action of the centrifugal advance causes the contact points to open sooner, or the trigger wheel and pickup coil turn off the ECU sooner. This causes the ignition coil to fire with the engine pistons not as far up in the cylinders.

### **Vacuum Advance**

The vacuum advance provides additional spark advance when engine load is low at part throttle position. It is a method of matching ignition timing with engine load. The vacuum advance increases FUEL ECONOMY because it helps maintain idle fuel spark advance at all times. A vacuum advance consists

of a vacuum diaphragm, link, movable distributor plate, and a vacuum supply hose.

At idle, the vacuum port from the carburetor or throttle body to the distributor advance is covered, thereby NO vacuum is applied to the vacuum diaphragm, and spark timing is NOT advanced. At part throttle, the throttle valve uncovers the vacuum port and the port is exposed to engine vacuum. The vacuum pulls the diaphragm outward against spring force. The diaphragm is linked to a movable distributor plate, which is rotated against distributor shaft rotation and spark timing is advanced.

The vacuum advance does not produce any advance at full throttle. When the throttle valve is wide open, vacuum is almost zero. Thus vacuum is NOT applied to the distributor diaphragm and the vacuum advance does NOT operate.

### **Computerized Advance**

The computerized advance, also known as an electronic spark advance system, uses various engine sensors and a computer to control ignition timing. The engine sensors check various operating conditions and send electrical data to the computer. The computer can change ignition timing for maximum engine efficiency.

Ignition system engine sensors include the following:

- ENGINE SPEED SENSOR (reports engine speed to the computer)
- CRANKSHAFT POSITION SENSOR (reports piston position)
- THROTTLE POSITION SWITCH (notes the position of the throttle)
- INLET AIR TEMPERATURE SENSOR (checks the temperature of the air entering the engine)
- ENGINE COOLANT TEMPERATURE SENSOR (measures the operating temperature of the engine)
- DETONATION SENSOR (allows the computer to retard timing when the engine knocks or pings)
- INTAKE VACUUM SENSOR (measures engine vacuum, an indicator of load)

The computer receives different current or voltage levels (input signals) from these sensors. It is

programmed to adjust ignition timing based on engine conditions. The computer may be mounted on the air cleaner, under the dash, on a fender panel, or under a seat.

The following is an example of the operation of a computerized advance. A vehicle is traveling down the road at 50 mph; the speed sensor detects moderate engine speed. The throttle position sensor detects part throttle and the air inlet and coolant temperature sensors report normal operating temperatures. The intake vacuum sensor sends high vacuum signals to the computer.

The computer receives all the data and calculates that the engine requires maximum spark advance. The timing would occur several degrees before TDC on the compression stroke. This action assures that high fuel economy is attained on the road.

If the operator began to pass another vehicle, intake vacuum sensor detects a vacuum drop to near zero and a signal is sent to the computer. The throttle position sensor detects a wide, open throttle and other sensor outputs say the same. The computer receives and calculates the data, then, if required, retards ignition timing to prevent spark knock or ping.

## IGNITION SYSTEM MAINTENANCE

Ignition troubles can result from a myriad of problems, from faulty components to loose or damaged wiring. Unless the vehicle stops on the job, the operator will report trouble indications, and the equipment is turned into the shop for repairs.

Unless the trouble is known, a systematic procedure should be followed to locate the cause. Remember, that electric current will follow the path of least resistance. Trace ignition wiring while checking for grounds, shorts, and open circuits. Bare wires, loose connections, and corrosion are found through visual inspection.

After checking the system, you must evaluate the symptoms and narrow down the possible causes. Use your knowledge of system operation, a service manual troubleshooting chart, basic testing methods, and common sense to locate the trouble. Many shops have specialized equipment that provide the mechanic a quick and easy means of diagnosing ignition system malfunctions.

### Spark Plugs and Spark Plug Wires

Bad spark plugs cause a wide range of problems—misfiring, lack of power, poor fuel economy, and hard

starting. After prolonged use, the spark plug tip can become coated with ash, oil, and other residue. The spark plug electrodes can also bum and widen the gap. This makes it more difficult for the ignition system to produce an electric arc between the electrodes.

To read spark plugs closely, inspect and analyze the condition of each spark plug tip and insulator. This will give you information on the condition of the engine, the fuel system, and the ignition system. The conditions commonly encountered with spark plugs areas follows:

- **NORMAL OPERATION** (fig. 2-47) appears as brown to grayish-tan deposit with slight electrode wear. This indicates the correct spark plug heat range and mixed periods of high- and low-speed operation. Spark plugs, having this appearance, may be cleaned, regapped, and reinstalled.
- **CARBON FOULED** (fig. 2-48) appears as dry, fluffy black carbon, resulting from slow operating speeds, wrong heat range (too cold), weak ignition (weak coil, worn ignition cables, etc.), faulty automatic choke, sticking manifold control valve, or rich air-fuel mixture. Spark plugs, having this appearance, may be cleaned, regapped, and reinstalled.
- **OIL FOULED** (fig. 2-49) appears as wet, oily deposits with very little electrode wear, resulting from worn rings, scored cylinder, or leaking valve seals. Spark plugs, having this appearance, may be degreased, cleaned, regapped, and reinstalled.



CMB2F200

Figure 2-47.—Normal operation.



Figure 2-48.—Carbon fouled.



Figure 2-50.—Ash fouled.



Figure 2-49.—Oil fouled.

electrodes, resulting from over-advanced timing, low-octane fuel, wrong spark plug heat range (too high), or a lean air-fuel mixture. Spark plugs, having this condition, are to be replaced with ones having the recommended heat range.

When a spark plug is removed for cleaning or inspection, it should be regapped by the engine manufacturer's specifications. New spark plugs are also to be regapped before installation, as they may have been dropped or mishandled and are not within specifications.

A wire type feeler gauge should be used to measure spark plug gap. Slide the feeler gauge between the electrodes. If needed, bend the side electrode until the feeler gauge fits snugly. The gauge should drag

- **ASH FOULED** (fig. 2-50) appears as red, brown, yellow, or white colored deposits which accumulate on the insulator, resulting from poor fuel quality or oil entering the cylinder. Most ash deposits have no adverse effect on the operation of the spark plug as long as they remain in a powdery state. However, under certain conditions these deposits melt and form a shiny glaze on the insulator which, when hot, acts as a good electrical conductor. This allows current to follow the deposit instead of jumping the gap, thus shorting out the spark plug. Spark plugs, having a powdery condition, may be cleaned, regapped, and replaced. Those having a glazed deposit are to be replaced.

- **PREIGNITION DAMAGE** (fig. 2-51) appears as burned or blistered insulator tips and badly worn



Figure 2-51.—Preignition damage.

slightly, as it is pulled in and out of the gap. Spark plug gaps vary from 0.30 inch on contact point ignitions to over 0.60 inch on electronic ignition systems.

When the spark plugs are being reinstalled, tighten them to the manufacturer's recommendation. Some manufacturers give spark plug torque, while others recommend bottoming the plugs on the seat and then turning an additional one-quarter to one-half turn. Refer to the manufacturer's service manual for exact procedures.

A faulty spark wire can either have a burned or broken conductor, or it could have deteriorated insulation. Most spark plug wires have a resistance conductor that can be easily separated. If the conductor is broken, voltage and current cannot reach the spark plug. If the insulation is faulty, sparks may leak through to ground or to another wire instead of reaching the spark plugs. To test the wires for proper operation, you can perform the following:

- **A SPARK PLUG WIRE RESISTANCE TEST** will check the spark plug conductor or coil wire conductor. To perform a wire resistance test, connect an ohmmeter across each end of the wire. The meter will read internal wire resistance in ohms. Typically resistance should NOT be over 5,000 ohms per inch or 100,000 ohms total. Since specifications vary, compare your readings to the manufacturer's specifications.

- **A SPARK PLUG WIRE INSULATION TEST** checks for sparks arcing through the insulation to ground. To perform an insulation test with the hood up, block out as much light as possible, start the engine, and move a grounded screwdriver next to the insulation. If a spark jumps through the insulation to the screwdriver, the wire is bad. Spark plug leakage is a condition in which electric arcs pass through the wire insulation.

Installing new spark plug wire is a simply task, especially when one wire at a time is replaced. Wire replacement is more complicated if all of the wires have been removed. Then you must use engine firing order and cylinder numbers to route each wire correctly. Service manuals can be used to trace the wires from each distributor cap tower to the correct spark plug.

### **Distributor Service**

The distributor is critical to the proper operation of the ignition system. The distributor senses engine speed, alters ignition timing, and distributes high voltage to the spark plugs. If any part of the distributor is faulty, engine performance suffers.

**DISTRIBUTOR CAP AND ROTOR.**—When problems point to possible distributor cap or rotor troubles, remove and inspect them. The distributor cap should be carefully checked to see that sparks have not been arcing from point to point. Both interior and exterior must be clean. The firing points should not be eroded, and the interior of the towers must be clean.

The rotor tip, from which the high-tension spark jumps to each distributor cap terminal, should not be worn. It also should be checked for excessive burning, carbon trace, looseness, or other damage. Any wear or irregularity will result in excessive resistance to the high-tension spark. Make sure that the rotor fits snugly on the distributor shaft.

A common problem arises when a **CARBON TRACE** (small line of carbonlike substance that conducts electricity) forms on the inside of the distributor cap or outer edge of the rotor. The carbon trace will short coil voltage to ground or to a wrong terminal lug in the distributor cap. A carbon trace will cause the spark plugs to either fire poorly or not at all.

Using a droplight, check the inside of the distributor cap for cracks and carbon trace. Carbon trace is black which makes it hard to see on a black-colored distributor cap. If carbon trace or a crack is found, replace the distributor cap or rotor.

**CONTACT POINT DISTRIBUTOR SERVICE.**—In a contact point distributor, there are two areas of concern—the contact points and the condenser.

Bad contact points cause a variety of engine performance problems. These problems include high-speed missing, no-start problem, and many other ignition troubles. Visually inspect the surfaces of the contact points to determine their condition. Points with burned and pitted contacts or with a worn rubbing block must be replaced. However, if the points look good, point resistance should be measured. Turn the engine over until the points are closed and then use an ohmmeter to connect the meter to the primary point lead and to ground. If resistance reading is too high, the points are burned and must be replaced.

A faulty condenser may leak (allow some dc current to flow to ground), be shorted (direct electrical connection to ground), or be opened (broken lead wire to the condenser foils). If the condenser is leaking or open, it will cause point arcing and burning. If the condenser is shorted, primary current will flow to ground and the engine will NOT start. To test a condenser using an ohmmeter, connect the meter to the

condenser and to ground. The meter should register slightly and then return to infinity (maximum resistance). Any continuous reading other than infinity indicates that the condenser is leaking and must be replaced.

Installing contact points is a relatively simple procedure but must be done with precision and care in order to achieve good engine performance and economy. Make sure the points are clean and free of any foreign material.

Proper alignment of the contact points is extremely important (fig. 2-52). If the faces of the contact points do not touch each other fully, heat generated by the primary current cannot be dissipated and rapid burning takes place. The contacts are aligned by bending the stationary contact bracket only. **NEVER BEND THE MOVABLE CONTACT ARM.** Ensure the contact arm-rubbing block rests flush against the distributor cam. A small amount of an approved lubricate should be placed on the distributor cam to reduce friction between the cam and rubbing block. Once the points are installed, they can be adjusted using either a feeler gauge or dwell meter.

To use a feeler gauge to set the contact points, turn the engine over until the points are **FULLY OPEN**. The rubbing block should be on top of a distributor cam lobe. With the points open, slide the specified thickness feeler gauge between them. Adjust the points so that there is a slight drag on the blade of the feeler gauge. Depending upon point design, use a screwdriver or Allen wrench to open and close the points. Tighten the hold-down screws and recheck the point gap. Typically point gap settings average around .015 inch for eight-cylinder engines and .025 inch for six- and four-cylinder engines. For the gap set of the engine you are working on, consult the manufacturer's service manual.

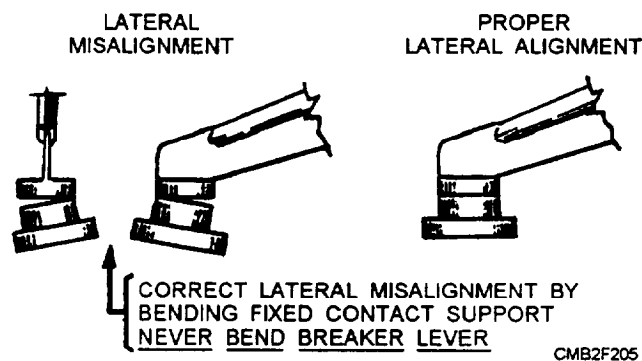

Figure 2-52.—Contact point alignment.

## CAUTION

Ensure the feeler gauge is clean before inserting it between the points. Oil and grease will reduce the service life of the points.

To use a dwell meter for adjusting contact points, connect the red lead of the dwell meter to the distributor side of the ignition coil (wire going to the contact points). Connect the black lead to ground.

If the distributor cap has an adjustment window, the points should be set with the engine running. With the meter controls set properly, adjust the points through the window of the distributor cap using a Allen wrench or a special screwdriver. Turn the point adjustment screw until the dwell meter reads within manufacturer's specification. However, if the distributor cap does not have an adjustment window, remove the distributor cap and ground the ignition coil wire. Then crank the engine; this action will simulate engine operation and allow point adjustment with the dwell meter.

Dwell specifications vary with the number of cylinders. An eight-cylinder engine requires 30 degrees of dwell. An engine with few cylinders requires more dwell time. Always consult the manufacturer's service manual for exact dwell values.

Dwell should remain constant as engine speed increases or decreases. However, if the distributor is worn, you can have a change in the dwell meter reading. This is known as **DWELL VARIATION**. If dwell varies more than 3 degrees, the distributor should either be replaced or rebuilt. Also, a change in the point gap or dwell will change ignition timing. For this reason, the points should always be adjusted before ignition timing.

**ELECTRONIC IGNITION DISTRIBUTOR SERVICE.**—Most electronic ignition distributors use a pickup coil to sense trigger wheel rotation and speed. The pickup coil sends small electrical impulses to the ECU. If the distributor fails to produce these electrical impulses properly, the ignition system can quit functioning.

A faulty pickup coil will produce a wide range of engine troubles, such as stalling, loss of power, or not starting at all. If the small windings in the pickup coil break, they will cause problems only under certain conditions. It is important to know how to test a pickup coil for proper operation.

The PICKUP COIL OHMETER TEST compares actual pickup resistance with the manufacturer's specifications. If the resistance is too high or low, the pickup coil is faulty. To perform this test, connect the ohmmeter across the output leads of the pickup coil. Wiggle the wire to the pickup coil and observe the meterreading. This will assist in locating any breaks in the wires to the pickup. Also, using a screwdriver, lightly tap the coil. This action will uncover any break in the coil windings.

Pickup coil resistance varies between 250 and 1,500 ohms, and you should refer to the service manual for exact specifications. Any change in the readings during the pickup coil resistance test indicates the coil should be replaced. Refer to the manufacturer's service manual for instructions for the removal and replacement of the pickup coil.

Once the pickup coil has been replaced, it will be necessary to set the PICKUP COIL AIR GAP. The air gap is the space between the pickup coil and the trigger wheel tooth. To obtain an accurate reading, use a NON-MAGNETIC FEELER GAUGE (plastic or brass).

With one tooth of the trigger wheel pointing at the pickup coil, slide the correct thickness non-magnetic feeler gauge between the trigger wheel and the pickup coil. Move the pickup coil in or out until the correct air gap is set. Tighten the pickup coil screws and double-check the air gap setting.

## Ignition Timing

The ignition system must be timed so the sparks jump across the spark plug gaps at exactly the right time. Adjusting the distributor on the engine so that the spark occurs at this correct time is called setting the ignition timing. The ignition timing is normally set at idle or a speed specified by the engine manufacturer. Before measuring engine timing, disconnect and plug the vacuum advance hose going to the distributor. This action prevents the vacuum advance from functioning and upsetting the readings. Adjustment is made by loosening the distributor hold-down screw and turning the distributor in its mounting.

Turning the distributor housing against the distributor shaft rotation **ADVANCES THE TIMING**. Turning the distributor housing with shaft rotation **RETARDS THE TIMING**. Refer to figure 2-53.

When the ignition timing is **TOO ADVANCED**, the engine may suffer from spark knock or ping. When ignition timing is **TOO RETARDED**, the engine will have poor fuel economy and power and will be very

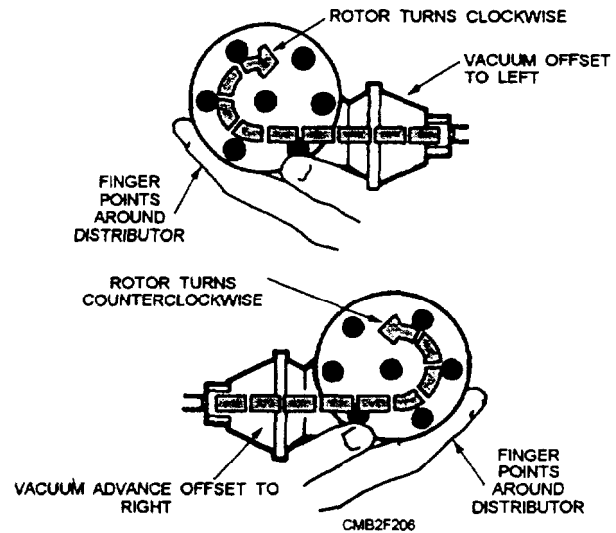

Figure 2-53.—Determining the direction of rotor rotation.

sluggish during acceleration. If extremely retarded, combustion flames blowing out of the open exhaust valve can overheat the engine and crack the exhaust manifolds.

A timing light is used to measure ignition timing. It normally has three leads—two small leads that connect to the battery—and one larger lead that connects to the NUMBER ONE spark plug wire. Depending on the type of timing light, the large lead may clip around the plug wire (inductive type), or it may need to be connected directly to the metal terminal of the plug wire (conventional type).

Draw a chalk line over the correct timing mark. This will make it easier to see. The timing marks may be either on the front cover in harmonic balance of the engine, or they may be on the engine flywheel.

With the engine running, aim the flashing timing light at the timing mark and reference pointer. The flashing timing light will make the mark appear to stand still. If the timing mark and the pointer do not line up, turn the distributor in its mounting until the timing mark and pointer are aligned. Tighten the distributor hold-down screw.

## CAUTION

Keep your hands and the timing light leads from the engine fan and belts. The spinning fan and belts can damage the light or cause serious personal injury.

After the initial ignition timing, you should check to see if the automatic advance mechanism is working. This can be done by keeping the timing light flashes



aimed at the timing mark and gradually increasing speed. If the advance mechanism is operating, the timing mark should move away from the pointer. If the timing mark fails to move as the speed increases or it hesitates and then suddenly jumps, the advance mechanism is faulty and should either be repaired or replaced.

Replace the distributor vacuum line and see if timing still conforms to the manufacturer's specifications. If the timing is NOT advanced when the vacuum line is connected and the throttle is opened slightly, the vacuum advance unit or tubing is defective.

Most computer-controlled ignition systems have no provision for timing adjustment. A few, however, have a tiny screw or lever on the computer for small ignition timing changes.

A computer-controlled ignition system has what is known as BASE TIMING. Base timing is the ignition timing without computer-controlled advance. Base timing is checked by disconnecting a wire connector in the computer wiring harness. This wire connector may be found on or near the engine or sometimes next to the distributor. When in the base timing mode, a conventional timing light can be used to measure ignition timing. If ignition timing is not correct, you can rotate the distributor, in some cases, or move the mounting for the engine speed or crank position sensor. If base timing cannot be adjusted, the electronic control unit or other components will have to be replaced. Always refer to the manufacturer's service manual when timing a computer-controlled ignition system.

### REVIEW 3 QUESTIONS

- Q1. *Of the two circuits within the ignition circuit, which one uses conventional wiring?*
- Q2. *What component of the ignition circuit acts as a pulse type transformer for producing a short burst of high voltage?*
- Q3. *What are the two type of sparkplugs?*
- Q4. *What factors determine the heat range of a spark plug?*
- Q5. *The smaller the number designator for a spark plug, the hotter the sparkplug. (T/F)*
- Q6. *The amount of time in degrees that the contact points remain closed between each opening is known by what term?*
- Q7. *In an electronic ignition system, the trigger wheel replaces what contact point ignition component?*
- Q8. *In a computerized advance, which sensor allows the computer to retard timing when the engine knocks or pings?*
- Q9. *The condition that exists when an electric arc passes through the insulation of a spark plug wire is known by what term?*
- Q10. *What number of degrees can dwell vary before a distributor is either rebuilt or replaced?*
- Q11. *What tool is used to set the air gap of the pickup coil?*
- Q12. *What ignition timing condition adversely affects engine fuel economy and power?*
- Q13. *In a computer-controlled ignition system, the ignition timing without the computer-controlled advance is known by what term?*

### LIGHTING CIRCUIT

**Learning Objective:** Identify lighting-circuit components, their functions, and maintenance procedures.

The lighting circuit (fig. 2-54) includes the battery, vehicle frame, all the lights, and various switches that control their use. The lighting circuit is known as a single-wire system since it uses the vehicle frame for the return.

The complete lighting circuit of a vehicle can be broken down into individual circuits, each having one or more lights and switches. In each separate circuit, the lights are connected in parallel, and the controlling switch is in series between the group of lights and the battery.

The marker lights, for example, are connected in parallel and are controlled by a single switch. In some installations, one switch controls the connections to the battery, while a selector switch determines which of two circuits is energized. The headlights, with their high and low beams, are an example of this type of circuit.

In some instances, such as the courtesy lights, several switches may be connected in parallel so that any switch may be used to turn on the light.

When a wiring diagram is being studied, all light circuits can be traced from the battery through the ammeter to the switch (or switches) to the individual light.

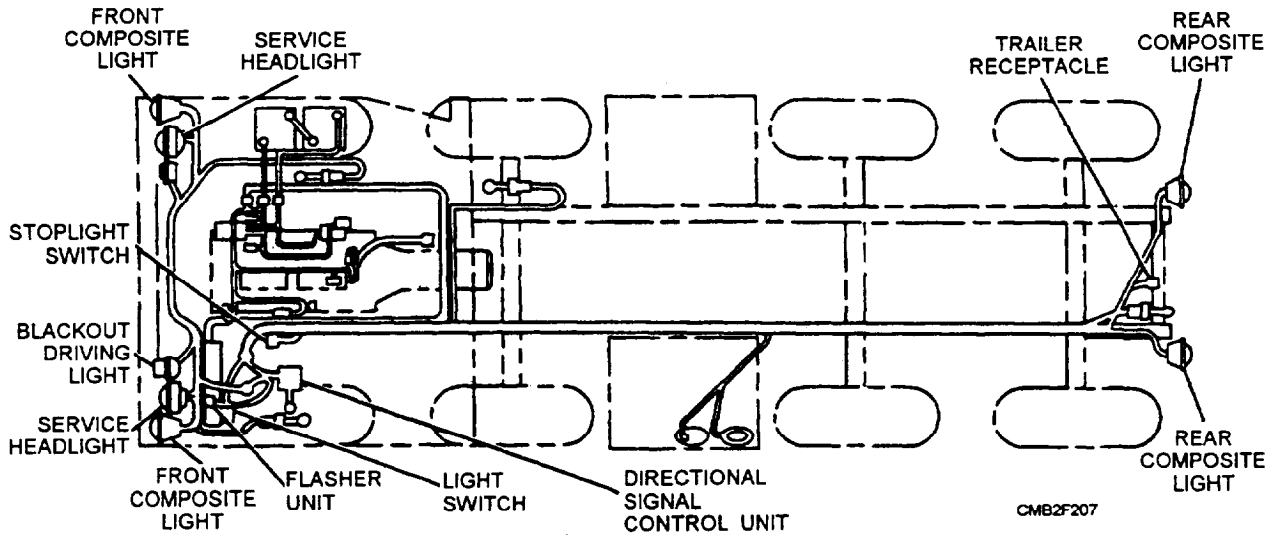

Figure 2-54.—Typical automotive lighting circuit.

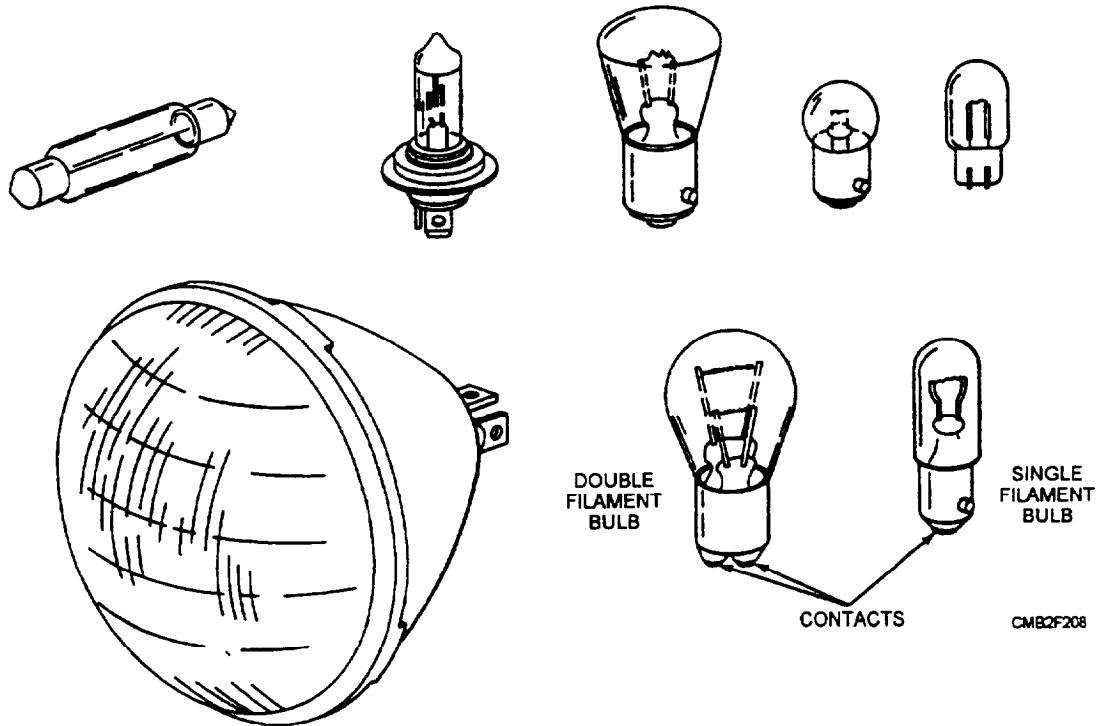

Figure 2-55.—Lamp construction and configurations.

## LAMPS

Small gas-filled incandescent lamps with tungsten filaments are used on automotive and construction equipment (fig. 2-55). The filaments supply the light when sufficient current is flowing through them. They are designed to operate on a low voltage current of 12 or 24 volts, depending upon the voltage of the electrical system used.

Lamps are rated as to size by the candlepower (luminous intensity) they produce. They range from

small one-half-candlepower bulbs to large 50-candlepower bulbs. The greater the candlepower of the lamp, the more current it requires when lighted. Lamps are identified by a number on the base.

When you replace a lamp in a vehicle, be sure the new lamp is of the proper rating. The lamps within the vehicle will be of the single- or double-contact types with nibs to fit bayonet sockets, as shown in figure 2-56.

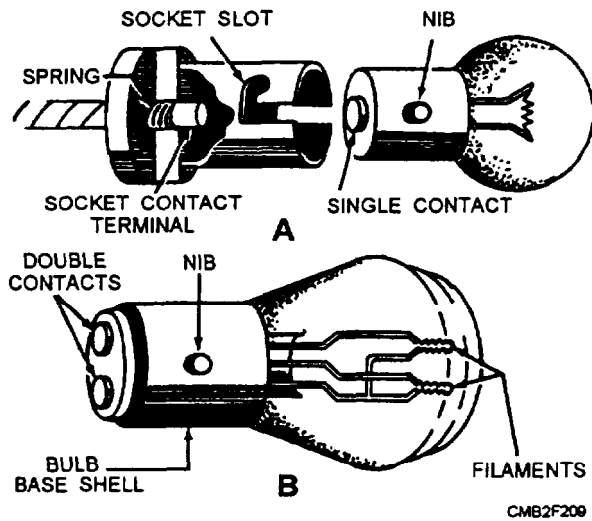

Figure 2-56.—(A) Single-contact bulb; (B) Double-contact bulb.

## HEADLIGHTS

The headlights are sealed beam lamps (fig. 2-57) that illuminate the road during nighttime operation. Headlights consist of a lens, one or two elements, and an integral reflector. When current flows through the element, the element gets white hot and glows. The reflector and lens direct the light forward.

Many modern passenger vehicles use halogen headlights. A halogen headlight contains a small, inner halogen lamp surrounded by a conventional sealed housing. A halogen headlamp increases light output by 25 percent with no increase in current. The halogen

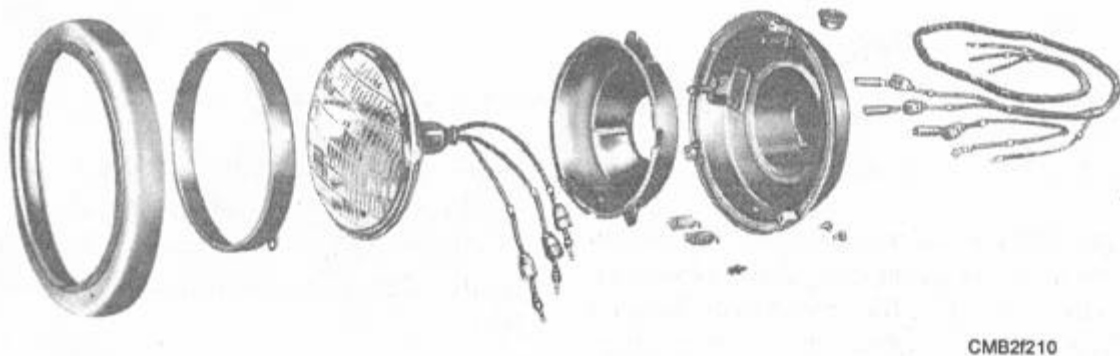

Figure 2-57.—A typical sealed beam headlight assembly.

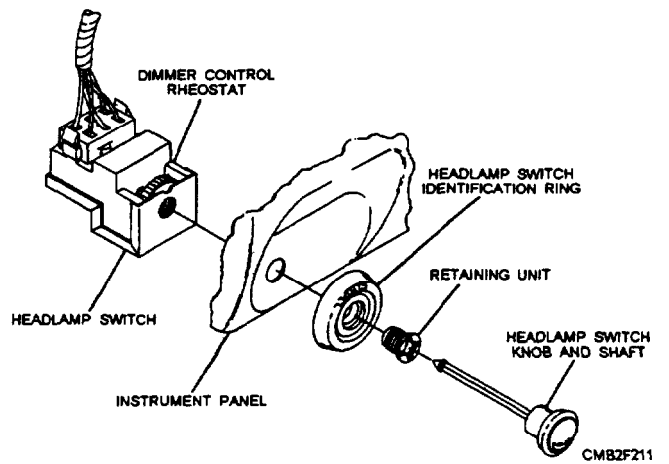

Figure 2-58.—Dash-mounted headlight switch.

lamp is also whiter than a conventional lamp, which increases lighting ability.

## Headlight Switch

The headlight switch is an ON/OFF switch and rheostat (variable resistor) in the dash panel (fig. 2-58) or on the steering column (fig. 2-59). The headlight switch controls current flow to the lamps of the headlight system. The rheostat is for adjusting the brightness of the instrument panel lights.

Military vehicles that are used in tactical situations are equipped with a headlight switch that is integrated with the blackout lighting switch (fig. 2-60). An important feature of this switch is that it reduces the possibility of accidentally turning on the lights in a

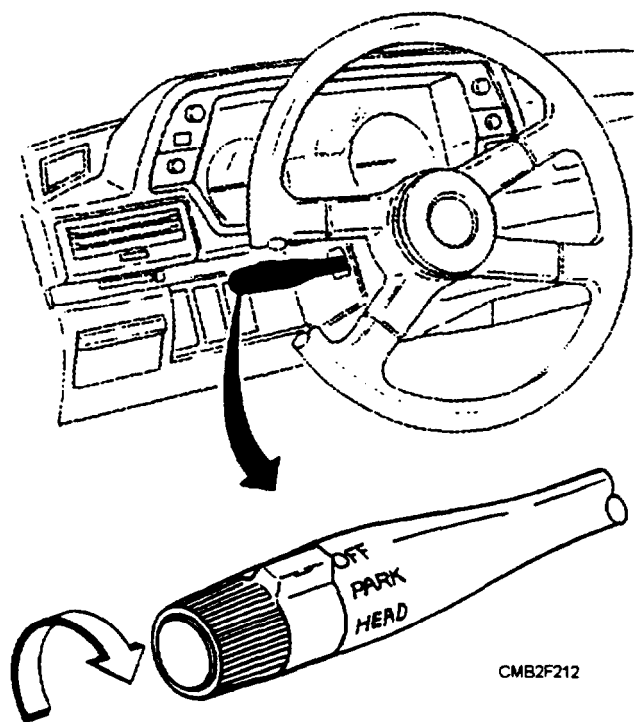

Figure 2-59.—Steering column mounted headlight switch.

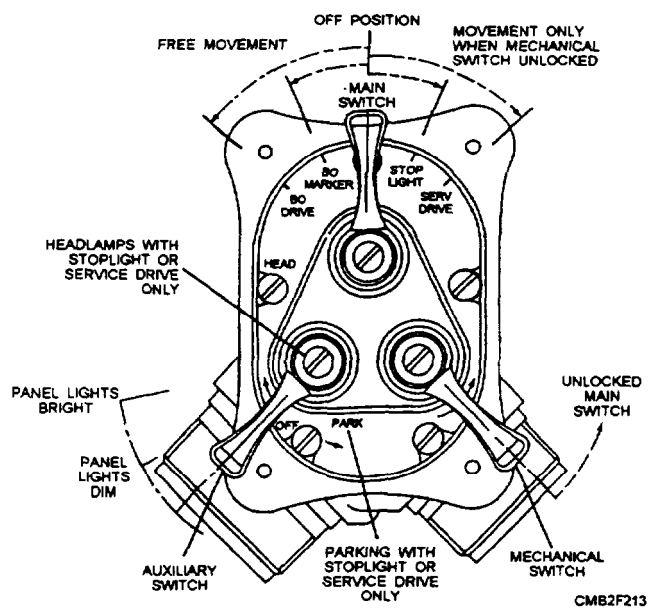

Figure 2-60.—Blackout light/headlight switch.

blackout. With no lights on, the main switch can be turned to the left without operating the mechanical switch to get blackout marker lights (including blackout taillights and stoplights) and blackout driving lights. But for stoplights for daylight driving or headlights for ordinary night driving, you must first lift the mechanical switch lever and then turn the main switch to the right. The auxiliary switch gives panel lights when the main switch is in any of its ON

positions. But it will give parking lights only when the main switch is in service drive (to the extreme right). When the main switch is off, the auxiliary switch should not be moved from the OFF position.

### Dimmer Switch

The dimmer switch controls the high and low headlamp beam function and is normally mounted on the floorboard (fig. 2-61) or steering column (fig. 2-62). When the operator activates the dimmer switch, it changes the electrical connection to the headlights.

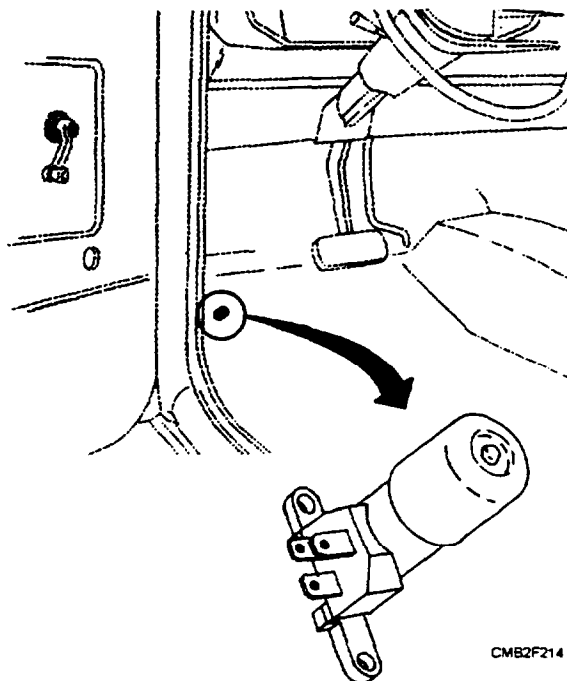

Figure 2-61.—Floor-mounted dimmer switch.

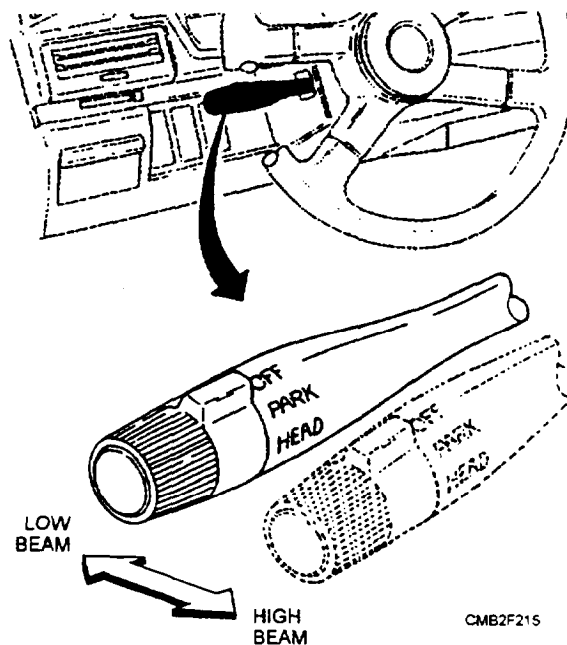

Figure 2-62.—Steering column mounted dimmer switch.

In one position, the high beams are turned on, and, in the other position, the dimmer changes them to low beam.

### Aiming Headlights

The headlights can be aimed using a mechanical aimer or a wall screen. Either method assures that the headlight beams point in the direction specified by the vehicle manufacturer. Headlights that are aimed too high can blind oncoming vehicles. Headlights that are aimed too low or to one side will reduce the operator's visibility.

To ensure that the headlights are properly aimed, you should have a half a tank of fuel, the correct tire pressure, and only the spare tire and jack in the vehicle. Some manufacturers recommend that someone sit in the operator and passenger seats while aiming the lights.

HEADLIGHT AIMERS are a device for pointing the vehicle headlights in a specified position. They may be permanently installed on a truck or may be portable. Some require a level floor, and others have internal leveling mechanisms to allow for uneven shop floors. To use the aimer, follow the instructions for the specific type of equipment.

The HEADLIGHT AIMING SCREEN is a series of measured lines marked on a shop wall or on a framed easel for aiming the headlights of a vehicle. The screen should be no less than 10 feet wide and 42 inches high. When it is mounted on an easel with casters, the screen

should be no more than 12 inches from the floor. To comply with regulations of most localities, you should place the screen 25 feet ahead of the vehicle.

The accepted driving beam pattern for passenger vehicles will show the high intensity portion (hotspot) of the light rays centered on a horizontal line that is 2 inches below the center or horizontal reference line on the screen (fig. 2-63). This means that there will be a 2-inch drop of the light beam for every 25 feet of distance from the headlight.

Headlights on large trucks present a special problem because of the effect of a heavy load. At the same 25 feet, truck headlights should be aimed so that none of the high intensity portion of the light will project higher than a level of 5 inches below the center on the headlight being tested. This is necessary to compensate for the variations in loading.

When using a screen for aiming the headlights on a vehicle that uses a four-headlight system, adjust the hotspots of the No. 1 (inboard) lights so that they are centered on the vertical lines 2 inches below the horizontal line (fig. 2-64). The low beam of the No. 2 (outboard) lights is aimed so that the hotspot does not extend to the left of straight ahead or extend more than 6 inches to the right of straight ahead. The top of the hotspot of the No. 2 lights is aimed at the horizontal line. When the No. 2 lights are properly adjusted, the high beam will be correct.

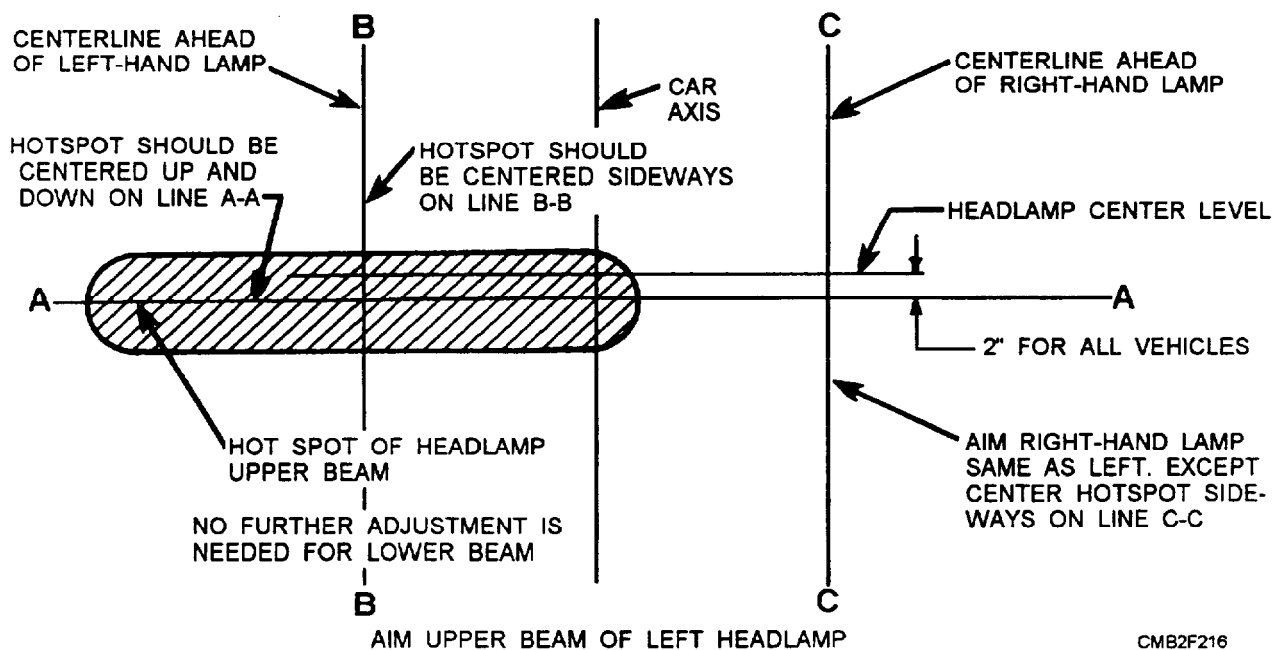

Figure 2-63.—Accepted beam pattern for aiming passenger vehicle headlights.

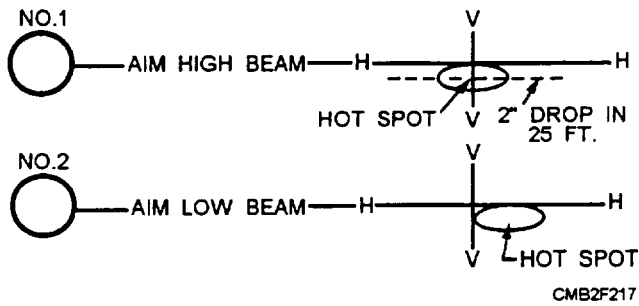

Figure 2-64.—Accepted beam pattern for a four-headlight system.

### BLACKOUT LIGHTS

Blackout lighting is a requirement for certain combat operations. The purposes of blackout lighting are as follows:

- To provide the vehicle operator with sufficient light to operate the vehicle in total darkness
- To provide minimum lighting to show vehicle position to a leading or trailing vehicle when illumination must be restricted to a level not visible to a distant enemy

The three types of blackout lighting are as follows:

- The BLACKOUT DRIVING LIGHT (fig. 2-65) is designed to provide a white light of 25 to 50 candlepower at a distance of 10 feet directly in front of the light. The light is shielded so that the

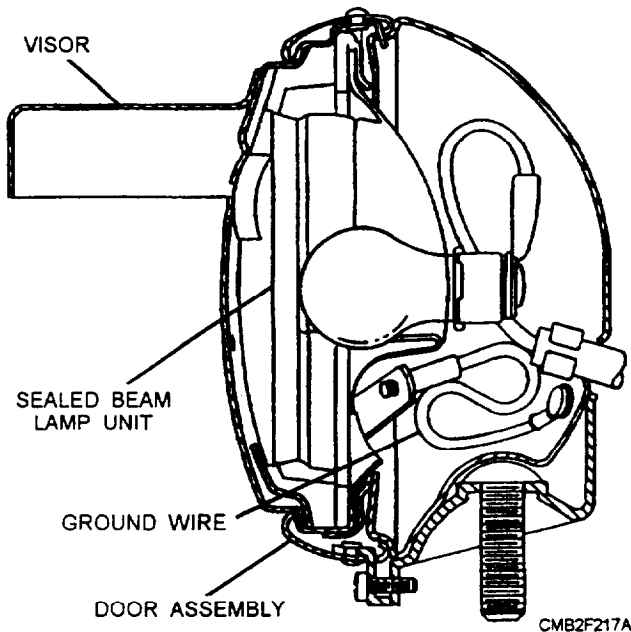

Figure 2-65.—Blackout driving light.

top of the low beam is directed not less than 2 degrees below the horizon. The beam distribution on a level road at 100 feet from the light is 30 feet wide.

- The BLACKOUT STOP/TAILLIGHT and MARKER LIGHT (fig. 2-66) are designed to be visible at a horizontal distance of 800 feet and not visible beyond 1,200 feet. The lights also must be invisible from the air above 400 feet with the vehicle on upgrades and downgrades of 20 percent. The horizontal beam cutoff for the lights is 60 degrees right and left of the beams center line at 100 feet.
- The COMPOSITE LIGHT (fig. 2-67) is currently the standard light unit that is used on the rear of tactical military vehicles. The composite light combines service stop, tail, and turn signals with blackout stop and taillighting.

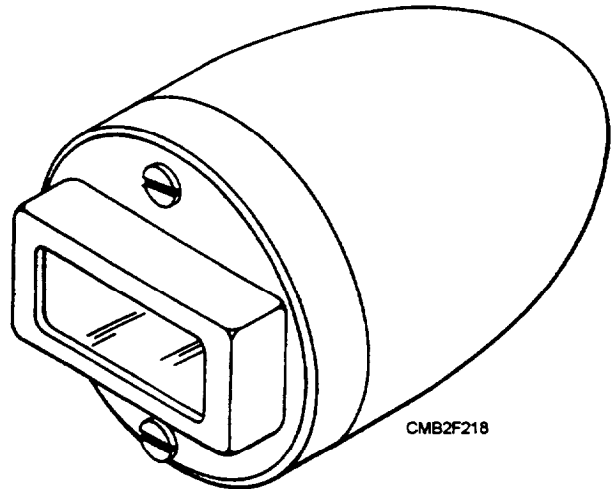

Figure 2-66.—Blackout stop/taillight and marker light.

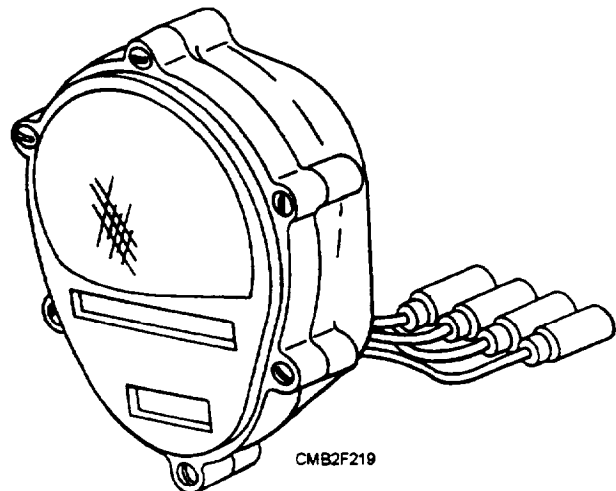

Figure 2-67.—Military composite light.

Blackout lighting control switches are designed to prevent the service lighting from being turned on accidentally. Their operation is described in the "Headlight Switch" section of this TRAMAN.

### TURN-SIGNAL SYSTEMS

Vehicles that operate on any public road must be equipped with turn signals. These signals indicate a left or right turn by providing a flashing light signal at the rear and front of the vehicle.

The turn-signal switch is located on the steering column (fig. 2-68). It is designed to shut off automatically after the turn is completed by the action of the canceling cam.

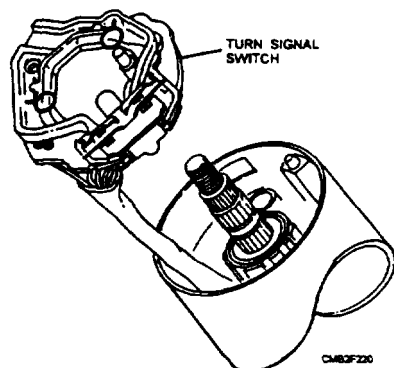

Figure 2-68.—Typical turn-signal switch.

A wiring diagram for a typical turn-signal system is shown in figure 2-69. A common design for a turn-signal system is to use the same rear light for both the stop and turn signals. This somewhat complicates the design of the switch in that the stoplight circuit must pass through the turn-signal switch. When the turn-signal switch is turned off, it must pass stoplight current to the rear lights. As a left or right turn signal is selected, the stoplight circuit is open and the turn-signal circuit is closed to the respective rear light.

The turn signal flasher unit (fig. 2-70) creates the flashing of the turn signal lights. It consists basically of a bimetallic (two dissimilar metals bonded together) strip wrapped in a wire coil. The bimetallic strip serves as one of the contact points.

When the turn signals are actuated, current flows into the flasher—first through the heating coil to the bimetallic strip, then through the contact points, then out of the flasher, where the circuit is completed through the turn-signal light. This sequence of events will repeat a few times a second, causing a steady flashing of the turn signals.

### BACKUP LIGHT SYSTEM

The backup light system provides visibility to the rear of the vehicle at night and a warning to the

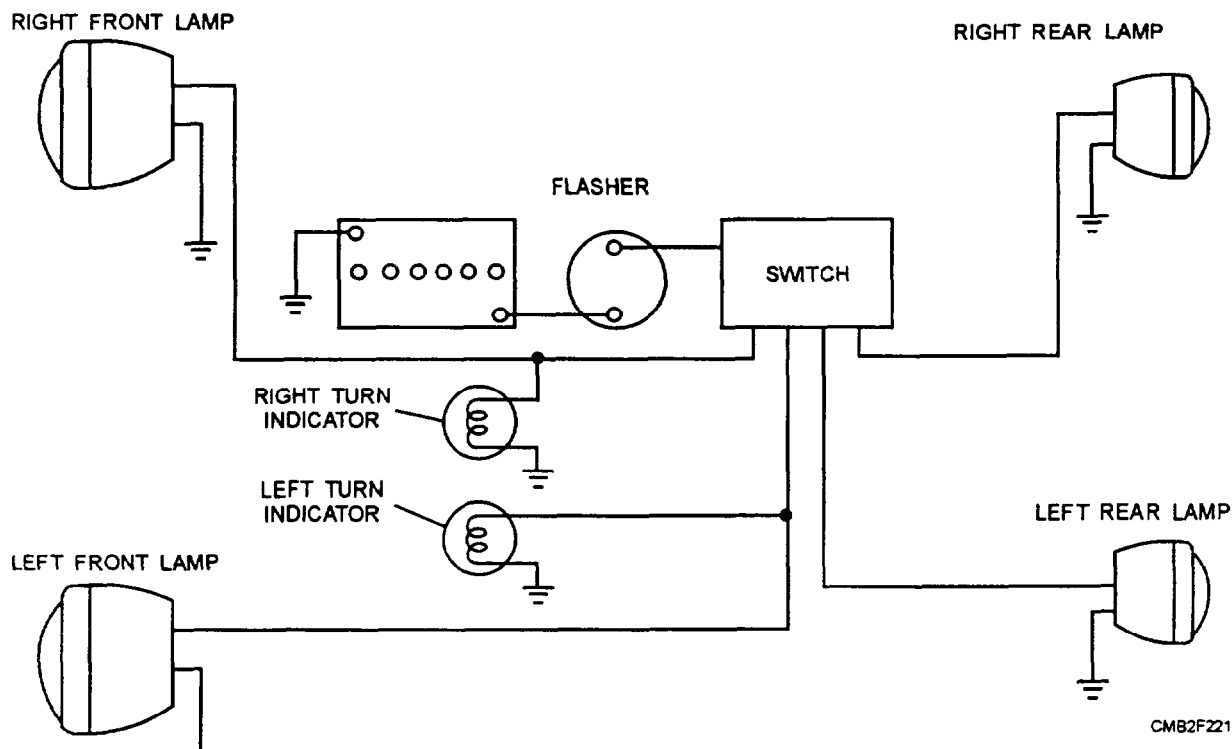

Figure 2-69.—Typical turn-signal wiring diagram.

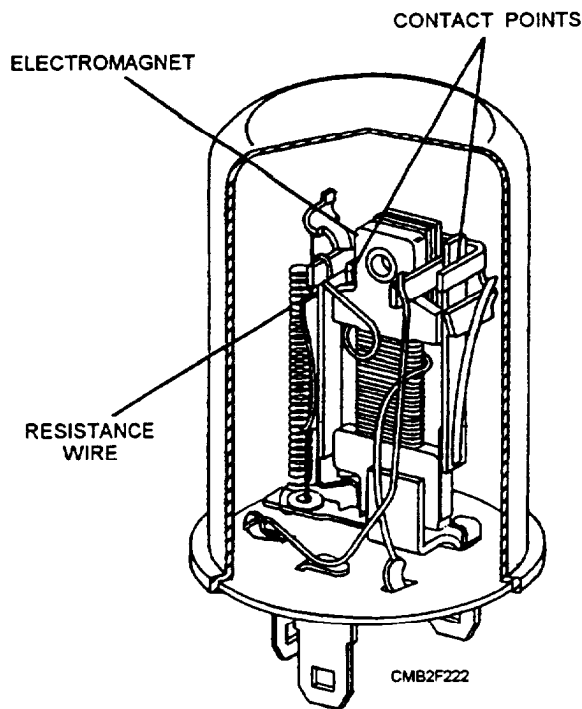

Figure 2-70.—Turn signal flasher.

pedestrians, whenever the vehicle is shifted into reverse. The backup light system has a fuse, gearshift- or transmission-mounted switch, two backup lights, and wiring to connect these components.

The backup light switch closes the light circuit when the transmission is shifted into reverse. The most common backup light switch configurations are as follows:

- The backup light switch mounted on the transmission and operated by the shift lever.
- The backup light switch mounted on the steering column and operated by the gearshift linkage.
- The transmission- or gearshift-mounted backup light switch on many automatic transmission-

equipped vehicles is combined with the neutral safety switch.

## STOPLIGHT SYSTEM

All vehicles that are used on public highways must be equipped with a stoplight system. The stoplight system consists of a fuse, brake light switch (fig. 2-71), two rear warning lights, and related wiring.

The brake light switch on most automotive equipment is mounted on the brake pedal. When the brake pedal is pressed, it closes the switch and turns on the rear brake lights. On construction and tactical equipment, you may find a pressure light switch. This type of switch uses either air or hydraulic pressure, depending on the equipment. It is mounted on the master cylinder of the hydraulic brake system or is attached to the brake valve on an air brake system. As the brakes are depressed, either air or hydraulic pressure builds on a diaphragm inside the switch. The diaphragm closes allowing electrical current to turn on the rear brake lights.

## EMERGENCY LIGHT SYSTEM

The emergency light system, also termed hazard warning system, is designed to signal oncoming traffic that a vehicle has stopped, stalled, or has pulled up to the side of the road. The system consists of a switch, flasher unit, four turn signal lights, and related wiring. The switch is normally a push-pull switch and is mounted on the steering column.

When the switch is closed, current flows through the emergency flasher. Like a turn signal flasher, the emergency flasher opens and closes the circuit to the lights. This causes all four turn signals to flash.

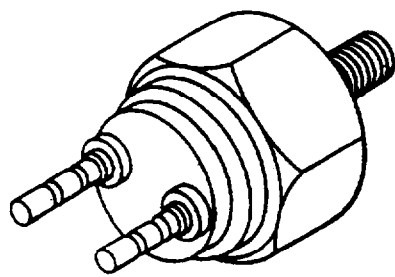

HYDRAULIC

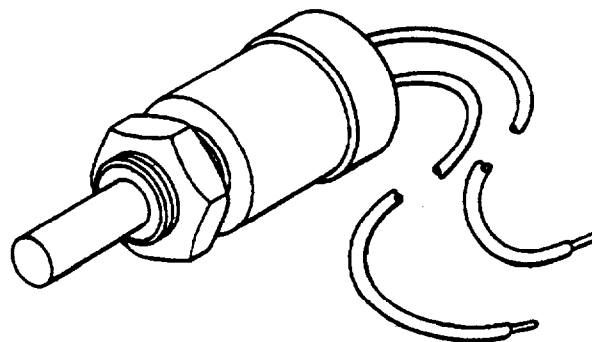

MECHANICAL

CMB2F223

Figure 2-71.—Brake light switches.



## CIRCUIT BREAKERS AND FUSES

Fuses are safety devices placed in electrical circuits to protect wires and electrical units from a heavy flow of current. Each circuit, or at least each individual electrical system, is provided with a fuse that has an ampere rating for the maximum current required to operate the units. The fuse element is made from metal with a low-melting point and forms the weakest point of the electrical circuit. In case of a short circuit or other trouble, the fuse will be burned out first and open the circuit just as a switch would do. Examination of a burnt-out fuse usually gives an indication of the problem. A discolored sight glass indicates the circuit has a short either in the wiring or in one of its components. If the glass is clear, the problem is an overloaded circuit. Be sure when replacing a fuse that it has a rating equal to the one burned out. Ensure that the trouble of the failure has been found and repaired.

A circuit breaker performs the same function as a fuse. It disconnects the power source from the circuit when current becomes too high. The circuit breaker will remain open until the trouble is corrected. Once the trouble is corrected, a circuit breaker will automatically reset itself when current returns to normal levels. The fuses and circuit breakers can usually be found behind the instrument panel on a fuse block (fig. 2-72).

### REVIEW 4 QUESTIONS

- Q1. *By what percentage is light output increased when using halogen headlights?*
- Q2. *What component of the headlight switch allows for adjusting the brightness of the instrument panel lights?*

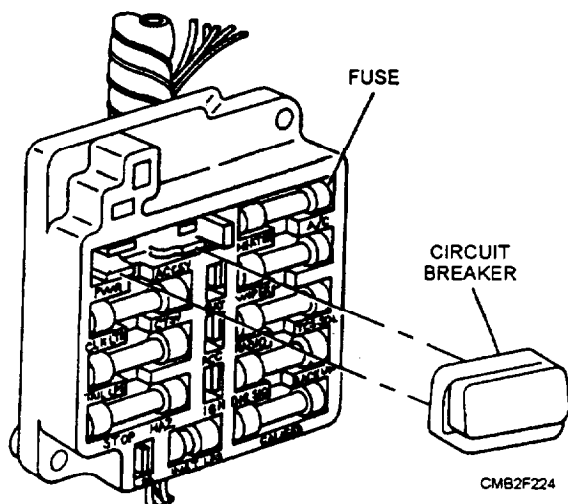

Figure 2-72.—Fuse block.

- Q3. *When using a headlight-aiming screen, you place the screen at what distance in front of the vehicle?*
- Q4. *On a 20 percent downgrade, blackout taillights should be invisible from the air at what distance?*
- Q5. *On most automotive vehicles, the brake light switch is mounted at what location?*

## INSTRUMENTS, GAUGES, AND ACCESSORIES

**Learning Objective:** Identify instrument, gauges, and accessories, their functions, and maintenance procedures.

The instrument panel is placed so that the instruments and gauges can easily be read by the operator. They inform the operator of the vehicle speed, engine temperature, oil pressure, rate of charge or discharge of the battery, amount of fuel in the fuel tank, and distance traveled. Vehicle accessories, such as windshield wipers and horns, provide the operator with much needed safety devices.

### BATTERY CONDITION GAUGE

The battery condition gauge is one of the most important gauges on the vehicle. If the gauge is interpreted properly, it can be used to troubleshoot or prevent breakdowns. The following are the three basic configurations of battery condition gauges—ammeter, voltmeter, and indicator lamp.

- The **AMMETER** is used to indicate the amount of current flowing to and from the battery. It does NOT give an indication of total charging output because of other units in the electrical system. If the ammeter shows a 10-ampere discharge, it indicates that a 100 ampere-hour battery would be discharged in 10 hours, as long as the discharge rate remained the same. Current flowing from the battery to the starting motor is never sent through the ammeter, because the great quantities of amperes used (200 to 600 amperes) cannot be measured due to its limited capacity. In a typical ammeter (fig. 2-73), all the current flowing to and from the battery, except for starting, actually is sent through a coil to produce a magnetic field that deflects the ammeter needle in proportion to the amount of current. The coil is matched to the maximum current output of the charging unit, and this varies with different applications.

- The **VOLTMETER** (fig. 2-74) provides a more accurate indication of the condition of the electrical

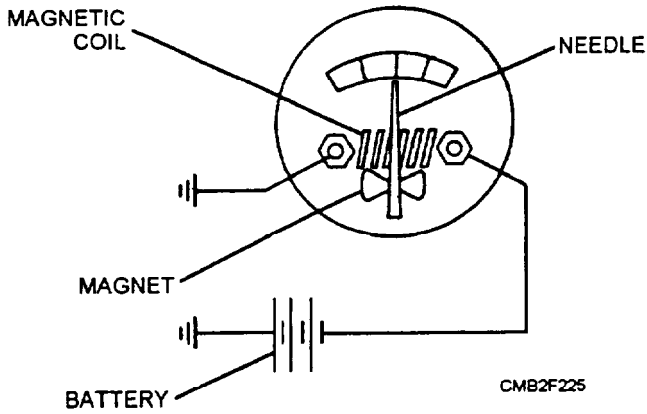

Figure 2-73.—Ammeter schematic.

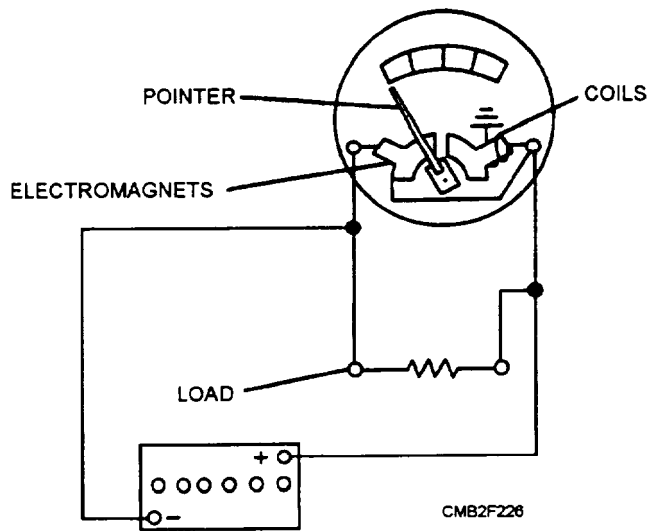

Figure 2-74.—Voltmeter schematic.

system and is easier to interpret by the operator. During vehicle operation, the voltage indicated on the voltmeter is considered to be normal in a range of 13.2

to 14.5 volts for a 12-volt electrical system. As long as the system voltage remains in this range, the operator can assume that no problem exists. This contrasts with an ammeter, which gives the operator no indication of problems, such as an improperly calibrated voltage regulator, which could allow the battery to be drained by regulating system voltage to a level below normal.

- The INDICATOR LAMP has gained popularity as an electrical system condition gauge over the years. Although it does not provide as detailed analysis of the electrical system condition as a gauge, it is considered more useful to the average vehicle operator. This is because it is highly visible when a malfunction occurs, whereas a gauge usually is ignored because the average vehicle operator does not know how to interpret its readings. The indicator lamp can be used in two different ways to indicate an electrical malfunction, which are as follows:

1. LOW VOLTAGE WARNING LAMP (fig. 2-75) is set up to warn the operator whenever the electrical system voltage has dropped below the normal operational range.
2. NO-CHARGE INDICATOR (fig. 2-76) is set up to indicate whenever the alternator is not producing current.

## FUEL GAUGE

Most fuel gauges are operated electrically and are composed of two units—the gauge, mounted on the instrument panel; and the sending unit, mounted in the fuel tank. The ignition switch is included in the fuel gauge circuit, so the gauge operates only when the ignition switch is in the ON position. Operation of the electrical gauge depends on either coil action or

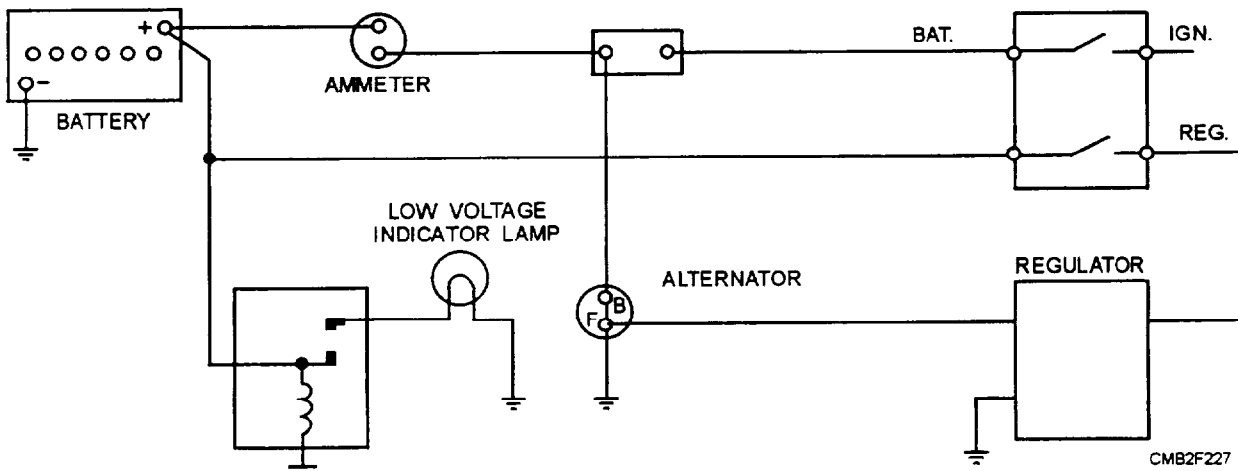

Figure 2-75.—Low voltage warning lamp schematic.

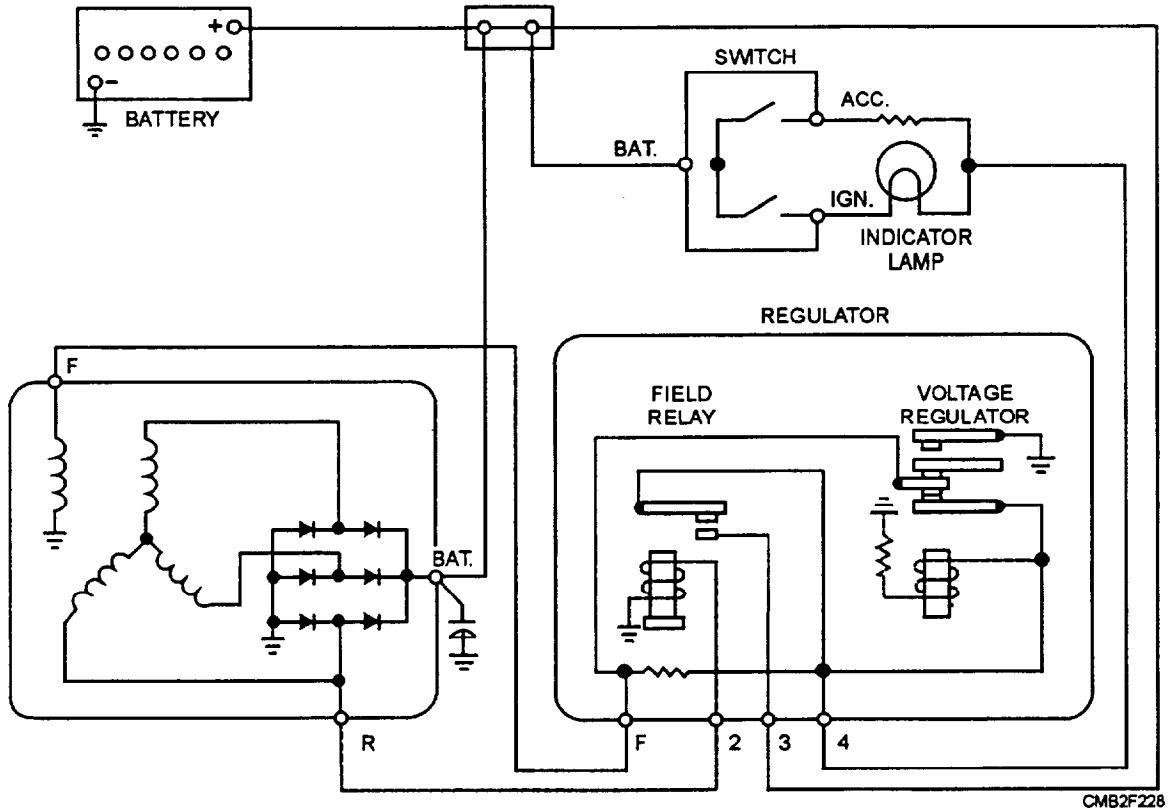

Figure 2-76.—No-charge indicator schematic.

thermostatic action. The four types of fuel gauges are as follows:

- The THERMOSTATIC FUEL GAUGE, SELF-REGULATING (fig. 2-77), contains an electrically heated bimetallic strip that is linked to a pointer. A bimetallic strip consists of two dissimilar metals that, when heated, expand at different rates, causing it to deflect or bend. In the case of this gauge, the deflection of the bimetallic strip results in the movement of the pointer, causing the gauge to give a reading. The sending unit consists of a hinged arm with a float on the end. The movement of the arm controls a grounded point that makes contact with another point which is attached to an electrically heated bimetallic strip. The heating coils in the tank and the gauge are connected to each other in series.

- The THERMOSTATIC FUEL GAUGE, EXTERNALLY REGULATED (fig. 2-78), differs from a self-regulating system in the use of a variable resistance fuel tank sending unit and an external voltage-limiting device. The sending unit controls the gauge through the use of a rheostat (wire wound resistance unit whose value varies with its effective length). The effective length of the rheostat is controlled in the sending unit by a sliding brush that is operated by

the float arm. The power supply to the gauge is kept constant through the use of a voltage limiter. The voltage limiter consists of a set of contact points that are controlled by an electrically heated bimetallic arm.

- The THERMOSTATIC FUEL GAUGE, DIFFERENTIAL TYPE (fig. 2-79), is similar to the other type of thermostatic fuel gauges, except that it uses two electrically heated bimetallic strips that share equally in operating and supporting the gauge pointer. The pointer position is obtained by dividing the available voltage between the two strips (differential). The tank unit is a rheostat type similar to that already described; however, it contains a wire-wound resistor that is connected between external terminals of one of the gauges of the bimetallic strip. The float arm moves a grounded brush that raises resistance progressively to one terminal, while lowering resistance to the other. This action causes the voltage division and resulting heat differential to the gauge strips formulating the gauge reading.

- The MAGNETIC FUEL GAUGE (fig. 2-80) consists of a pointer mounted on an armature. Depending upon the design, the armature may contain one or two poles. The gauge is motivated by a magnetic field that is created by two separate magnetic coils that

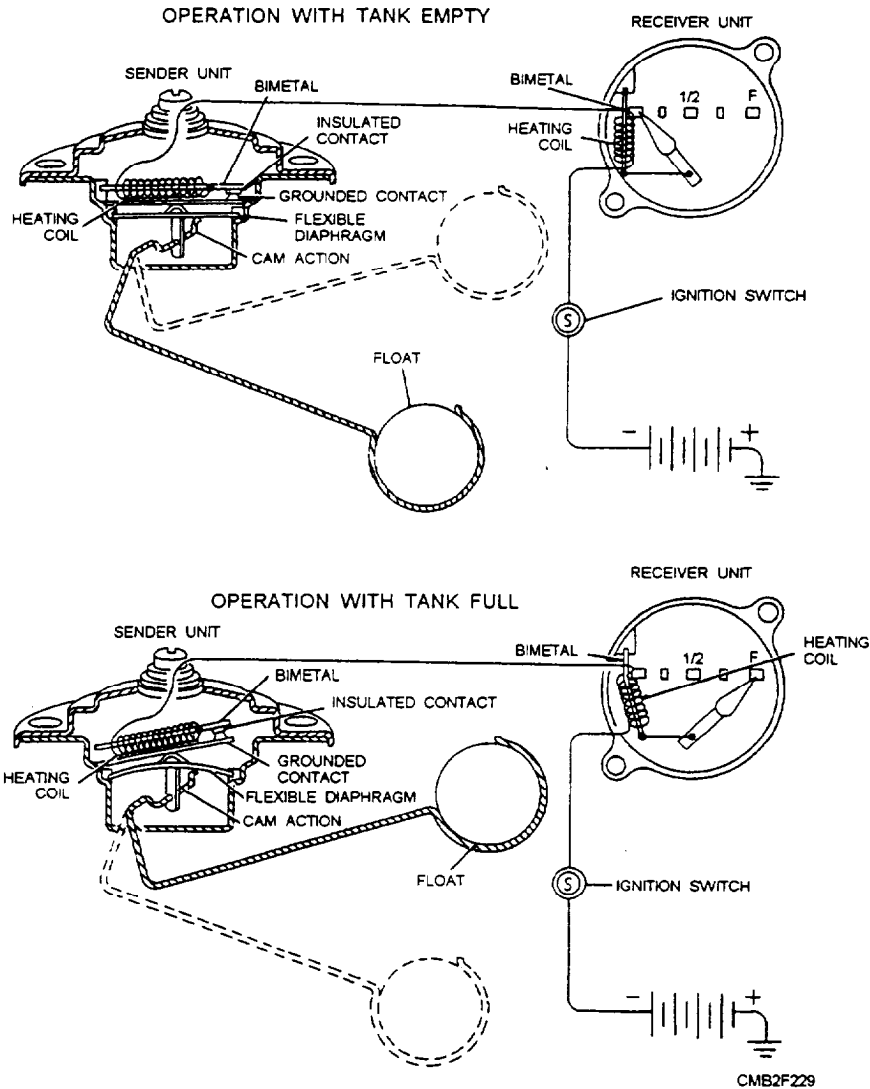

Figure 2-77.—Thermostatic fuel gauge, self-regulating.

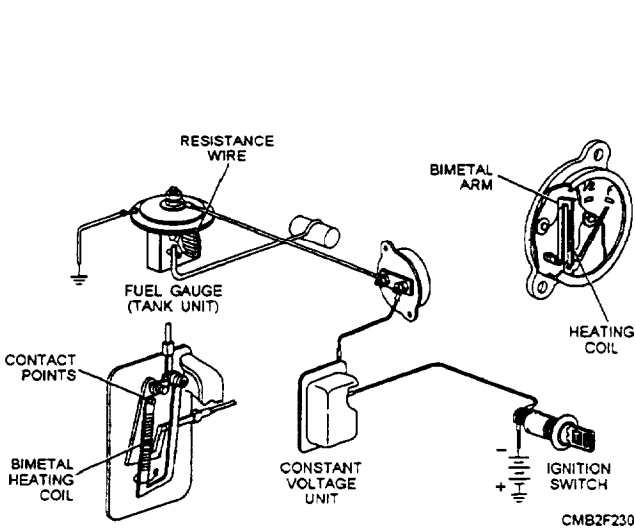

Figure 2-78.—Thermostatic fuel gauge, externally regulated.

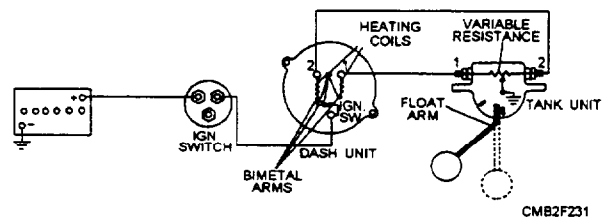

Figure 2-79.—Thermostatic fuel gauge, differential type.

are contained in the gauge. One of these coils is connected directly to the battery, producing a constant magnetic field. The other coil produces a variable field, whose strength is determined by a rheostat-type tank unit. The coils are placed 90 degrees apart.

### PRESSURE GAUGE

A pressure gauge is used widely in automotive and construction applications to keep track of such things as oil pressure, fuel line pressure, air brake system

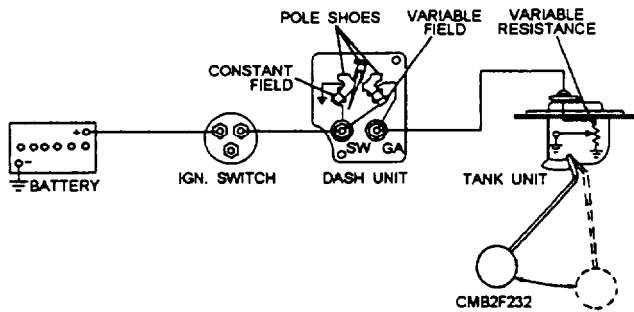

Figure 2-80.—Magnetic fuel gauge.

pressure, and the pressure in the hydraulic systems. Depending on the equipment, a mechanical gauge, an electrical gauge, or an indicator lamp may be used.

- The MECHANICAL GAUGE (fig. 2-81) uses a thin tube to carry an actual pressure sample directly to the gauge. The gauge basically consists of a hollow, flexible C-shaped tube, called a bourbon tube. As air or fluid pressure is applied to the bourbon tube, it will tend to straighten out. As it straightens, the attached pointer will move, giving a reading.

- The ELECTRIC GAUGE may be of the thermostatic or magnetic type as previous discussed. The sending unit (fig. 2-82) that is used with each gauge type varies as follows:

1. The sending unit that is used with the thermostatic pressure gauge uses a flexible diaphragm that moves a grounded contact. The contact that mates with the grounded contact is attached to a bimetallic strip. The flexing of the diaphragm, which is done with pressure changes, varies the point tension. The different positions of the diaphragm produce gauge readings.

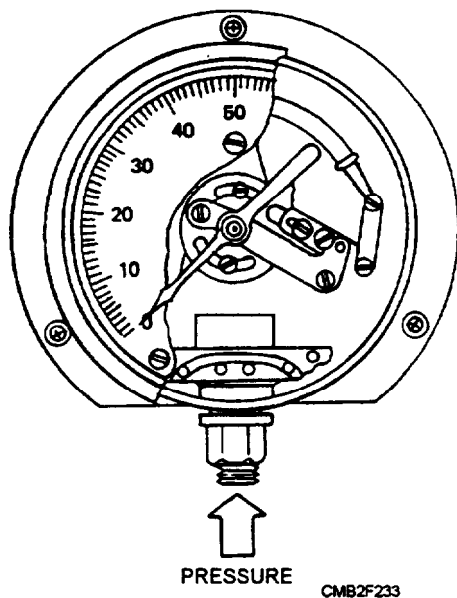

Figure 2-81.—Mechanical pressure gauge.

2. The sending unit that is used with the magnetic-type gauge also translates pressure into the flexing of a diaphragm. In the case of the magnetic gauge sending unit, however, the diaphragm operates a rheostat.

- The INDICATOR LAMP (warning light) is used in place of a gauge on many vehicles. The warning light, although not an accurate indicator, is valuable because of its high visibility in the event of a low-pressure condition. The warning light receives battery power through the ignition switch. The circuit to ground is completed through a sending unit. The sending unit consists of a pressure-sensitive diaphragm that operates a set of contact points that are calibrated to turn on the warning light whenever pressure drops below a set pressure.

## TEMPERATURE GAUGE

The temperature gauge is a very important indicator in construction and automotive equipment. The most common uses are to indicate engine coolant, transmission, differential oil, and hydraulic system temperature. Depending on the type of equipment, the gauge may be mechanical, electric, or a warning light.

- The ELECTRIC GAUGE may be the thermostatic or magnetic type, as described previously. The sending unit (fig. 2-83) that is used varies, depending upon application.

1. The sending unit that is used with the thermostatic gauge consists of two bimetallic strips, each having a contact point. One bimetallic strip is heated electrically. The other strip bends to increase the tension of the contact points. The different positions of the bimetallic strip create the gauge readings.

2. The sending unit that is used with the magnetic gauge contains a device called a thermistor. A thermistor is an electronic device whose resistance decreases proportionally with an increase in temperature.

- The MAGNETIC GAUGE contains a bourbon tube and operates by the same principles as the mechanical pressure gauge.

- The INDICATOR LAMP (warning light) operates by the same principle as the indicator light previously discussed.

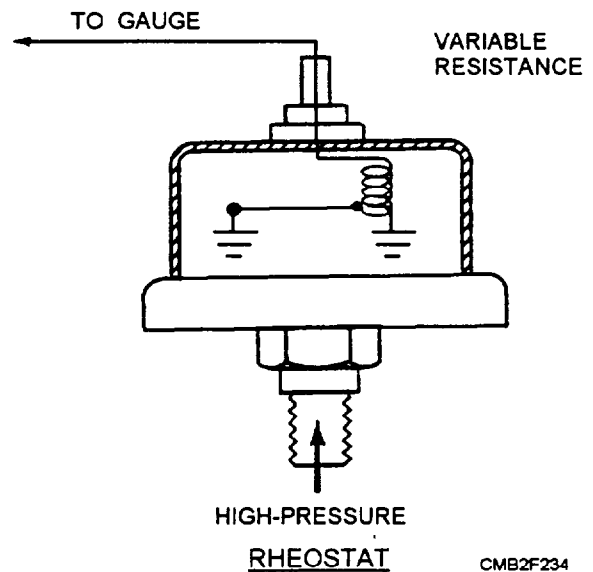
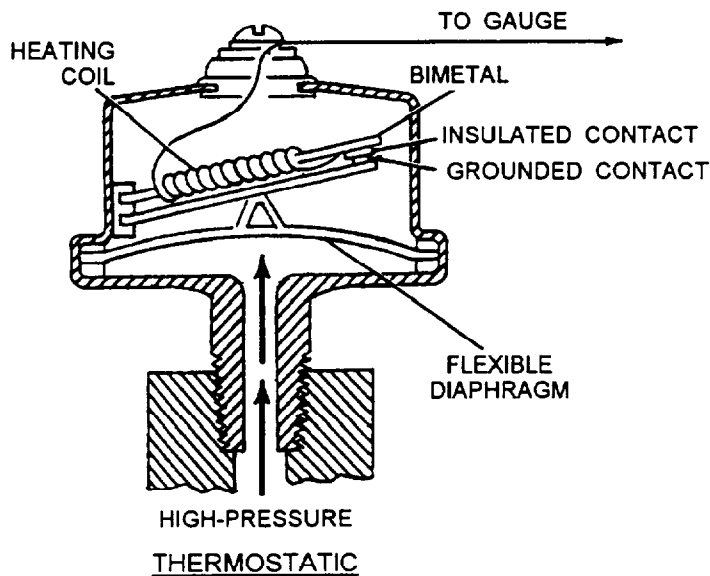

CMB2F234

Figure 2-82.—Types of sending units for pressure gauges.

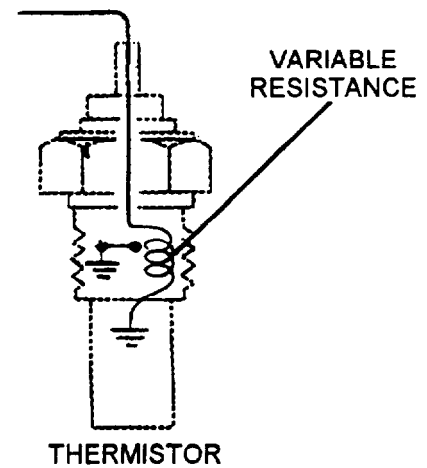
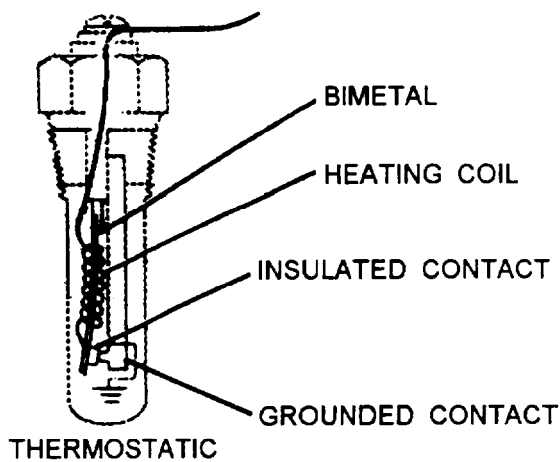

CMB2F235

Figure 2-83.—Types of temperature gauge sending units.

## SPEEDOMETER AND TACHOMETERS

Speedometers and tachometers in some form are used in virtually all types of self-propelled equipment. Speedometers are used to indicate vehicle speed in miles per hour (mph) or kilometers per hour (kph). In most cases, the speedometer also contains the odometer which keeps a record of the amount of mileage (in miles or kilometers depending on application) that a vehicle has accumulated. Some speedometers also contain a resettable trip odometer so those individual trips can be measured.

A tachometer is a device that is used to measure engine speed in revolutions per minute (rpm). The tachometer may also contain an engine-hour gauge which is installed on equipment that uses no odometer to keep a record of engine use. Speedometers and tachometers may be driven either mechanically, electrically, or electronically.

### Mechanical Speedometers and Tachometers

Both the mechanical speedometer and the tachometer consist of a permanent magnet that is

rotated by a flexible shaft. Surrounding the rotating magnet is a metal cup that is attached to the indicating needle. The revolving magnetic field exerts a pull on the cup that forces it to rotate. The rotation of the cup is countered by a calibrated hairspring. The influence of the hairspring and the rotating magnetic field on the cup produces accurate readings by the attached needle. The flexible shaft consists of a flexible outer casing that is made of either steel or plastic and an inner drive core that is made of wire-wound spring steel. Both ends of the core are molded square, so they can fit into the driving member at one end and the driven member at the other end and can transmit torque.

Gears on the transmission output shaft turn the flexible shaft that drives the speedometer. This shaft is referred to as the speedometer cable. A gear on the ignition distributor shaft turns the flexible shaft that drives the tachometer. This shaft is referred to as the tachometer cable.

The odometer of the mechanical speedometer is driven by a series of gears that originate at a spiral gear on the input shaft. The odometer consists of a series of drums with digits printed on the outer circumference that range from zero to nine. The drums are geared to each other so that each time the one furthest to the right makes one revolution, it will cause the one to its immediate left to advance one digit. The second to the right then will advance the drum to its immediate left one digit for every revolution it makes. This sequence continues to the left through the entire series of drums. The odometer usually contains six digits to record 99,999.9 miles or kilometers. However, models with

trip odometers do not record tenths, thereby contain only five digits. When the odometer reaches its highest value, it will automatically reset to zero. Newer vehicles incorporate a small dye pad in the odometer to color the drum of its highest digit to indicate the total mileage is in excess of the capability of the odometer.

### Electric Speedometers and Tachometers

The electric speedometer and tachometer use a mechanically driven permanent magnet generator to supply power to a small electric motor (fig. 2-84). The electric motor then is used to rotate the input shaft of the speedometer or tachometer. The voltage from the generator will increase proportionally with speed, and speed will likewise increase proportionally with voltage enabling the gauges to indicate speed.

The signal generator for the speedometer is usually driven by the transmission output shaft through gears. The signal generator for the tachometer usually is driven by the distributor through a power takeoff on gasoline engines. When the tachometer is used with a diesel engine, a special power takeoff provision is made, usually on the camshaft drive.

### Electronic Speedometers and Tachometers

Electronic speedometers and tachometers are self-contained units that use an electric signal from the engine or transmission. They differ from the electric unit in that they use a generated signal as the driving force. The gauge is transistorized and will supply information through either a magnetic analog (dial) or light-emitting diode (LED) digital gauge display. The

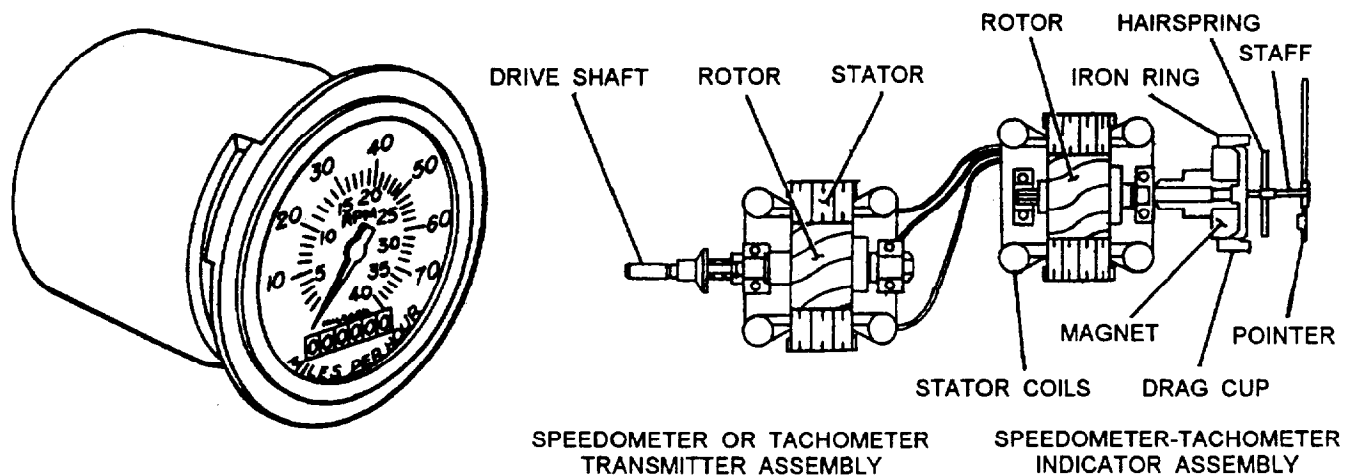

CMB2F236

Figure 2-84.—Electric speedometer and tachometer operation.

gauge unit derives its input signal in the following ways:

- An electronic tachometer obtains a pulse signal from the ignition distributor, as it switches the coil on and off. The pulse speed at this point will change proportionally with engine speed. This is the most popular signal source for a tachometer that is used on a gasoline engine.
- A tachometer that is used with a diesel engine uses the alternating current generated by the stator terminal of the alternator as a signal. The frequency of the ac current will change proportionally with engine speed.
- An electronic speedometer derives its signal from a magnetic pickup coil that has its field interrupted by a rotating pole piece. The signal units operation is the same as the operation of the retractor and pickup coil described earlier in this TRAMAN. The pickup coil is located strategically in the transmission case to interact with the retractor teeth on the input shaft.

## HORN

The horn currently used on automotive vehicles is the electric vibrating type. The electric vibrating horn system typically consists of a fuse, horn button switch, relay, horn assembly, and related wiring. When the operator presses the horn button, it closes the horn switch and activates the horn relay. This completes the circuit, and current is allowed through the relay circuit and to the horn.

Most horns have a diaphragm that vibrates by means of an electromagnetic. When the horn is energized, the electromagnet pulls on the horn diaphragm. This movement opens a set of contact points inside the horn. This action allows the diaphragm to flex back towards its normal position. This cycle is repeated rapidly. The vibrations of the diaphragm within the air column produce the note of the horn.

Tone and volume adjustments are made by loosening the adjusting locknut and turning the adjusting nut. This very sensitive adjustment controls the current consumed by the horn. Increasing the current increases the volume. However, too much current will make the horn sputter and may lock the diaphragm.

When a electric horn will not produce sound, check the fuse, the connections, and test for voltage at the horn terminal. If the horn sounds continuously, a faulty horn switch is the most probable cause. A faulty horn relay is

another cause of horn problems. The contacts inside the relay may be burned or stuck together.

## WINDSHIELD WIPERS

The windshield wiper system is one of the most important safety factors on any piece of equipment. A typical electric windshield wiper system consists of a switch, motor assembly, wiper linkage and arms, and wiper blades. The description of the components is as follows:

- The WINDSHIELD WIPER SWITCH is a multiposition switch, which may contain a rheostat. Each switch position provides for different wiping speeds. The rheostat, if provided, operates the delay mode for a slow wiping action. This permits the operator to select a delayed wipe from every 3 to 20 seconds. A relay is frequently used to complete the circuit between the battery voltage and the wiper motor.
- The WIPER MOTOR ASSEMBLY operates on one, two, or three speeds. The motor (fig. 2-85) has a worm gear on the armature shaft that drives one or two gears, and, in turn, operates the linkage to the wiper arms. The motor is a small, shunt wound dc motor. Resistors are placed in the control circuit from the switch to reduce the current and provide different operating speeds.
- The WIPER LINKAGE and ARMS transfers motion from the wiper motor transmission to the wiper blades. The rubber wiper blades fit on the wiper arms.
- The WIPER BLADE is a flexible rubber squeegee-type device. It may be steel or plastic backed and is designed to maintain total contact with the windshield throughout the stroke. Wiper blades should be inspected periodically. If they are hardened, cut, or split, they are to be replaced.

When electrical problems occur in the windshield wiper system, use the service manual and its wiring diagram of the circuit. First check the fuses, electrical connections, and all grounds. Then proceed with checking the components.

## REVIEW 5 QUESTIONS

- Q1. Which type of battery condition gauge provides the most accurate indication of the condition of the electrical system?*
- Q2. How is pointer position obtained in a differential type thermostatic fuel gauge?*
- Q3. The signal generator for an electric tachometer used on a gasoline engine is driven by what component?*



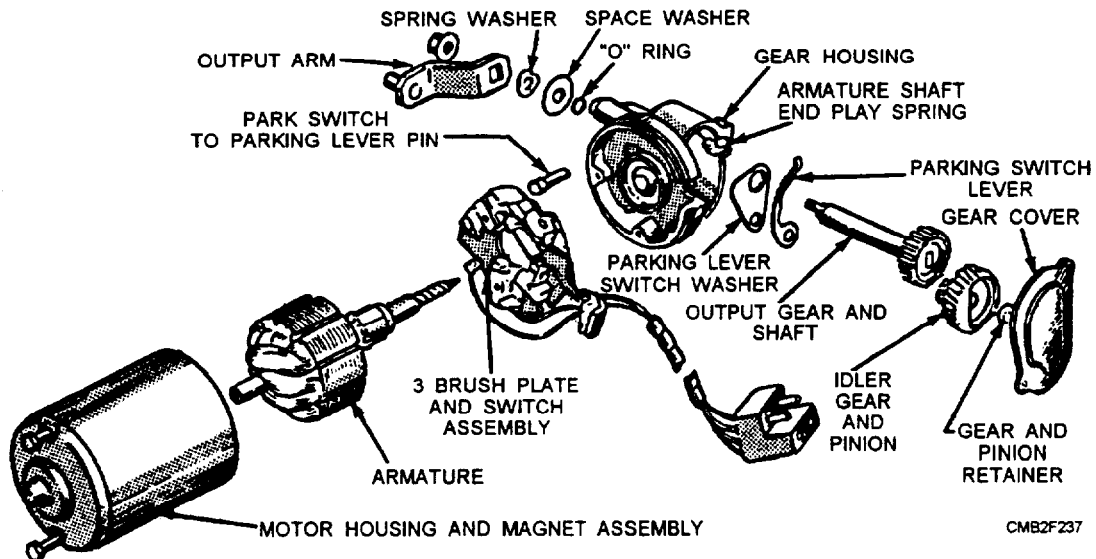

Figure 2-85.—Wiper motor assembly.

Q4. What is the most probable cause of a horn sounding continuously?

## AUTOMOTIVE WIRING

**Learning Objective:** Identify the basic types of automotive wiring, types of terminals, and wiring diagrams.

Electrical power and control signals must be delivered to electrical devices reliably and safely so that the electrical system functions are not impaired or converted to hazards. To fulfill power distribution military vehicles, use one- and two-wire circuits, wiring harnesses, and terminal connections.

Among your many duties will be the job of maintaining and repairing automotive electrical systems. All vehicles are not wired in exactly the same manner; however, once you understand the circuit of one vehicle, you should be able to trace an electrical circuit of any vehicle using wiring diagrams and color codes.

### ONE- AND TWO-WIRE CIRCUITS

Tracing wiring circuits, particularly those connecting lights or warning and signal devices, is no simple task. By studying the diagram in figure 2-72, you will see that the branch circuits making up the individual systems have one wire to conduct electricity from the battery to the unit requiring it and ground connections at the battery and the unit to complete the circuit. These are called **ONE-WIRE CIRCUITS** or branches of a **GROUND RETURN SYSTEM**. In automotive electrical systems with branch circuits that

lead to all parts of the equipment, the ground return system saves installation time and eliminates the need for an additional wiring to complete the circuit. The all-metal construction of the automotive equipment makes it possible to use this system.

The **TWO-WIRE CIRCUIT** requires two wires to complete the electrical circuit—one wire from the source of electrical energy to the unit it will operate, and another wire to complete the circuit from the unit back to the source of the electrical power.

Two-wire circuits provide positive connection for light and electrical brakes on some trailers. The coupling between the trailer and the equipment, although made of metal and a conductor of electricity, has to be jointed to move freely. The rather loose joint or coupling does not provide the positive and continuous connection required to use a ground return system between two vehicles. The two-wire circuit is commonly used on equipment subject to frequent or heavy vibrations. Tracked equipment, off-road vehicles (tactical), and many types of construction equipment are wired in this manner.

### WIRING ASSEMBLIES

Wiring assemblies consist of wires and cables of definitely prescribed length, assembled together to form a subassembly that will interconnect specific electrical components and/or equipment. The two basic types of wiring assemblies are as follows:

- The **CABLE ASSEMBLY** consists of a stranded conductor with insulation or a combination of insulated conductors enclosed in a covering or jacket from end to

end. Terminating connections seal around the outer jacket so that the inner conductors are isolated completely from the environment. Cable assemblies may have two or more ends.

- **WIRING HARNESS** assemblies (fig. 2-86) serve two purposes. They prevent chafing and loosening of terminals and connections caused by vibration and road shock while keeping the wires in a neat condition away from moving parts of the vehicle. Wiring harnesses contain two or more individual conductors laid parallel or twisted together and wrapped with binding material, such as tape, lacing cord, and wire ties. The binding materials do not isolate

the conductors from the environment completely, and conductor terminations may or may not be sealed. Wiring harnesses also may have two or more ends.

## WIRING IDENTIFICATION

Wires in the electrical system should be identified by a number, color, or code to facilitate tracing circuits during assembly, troubleshooting, or rewiring operations. This identification should appear on wiring schematics and diagrams and whenever practical on the individual wire. The assigned identification for a continuous electrical connection should be retained on a schematic diagram until the circuit characteristic is altered by a switching point or active component.

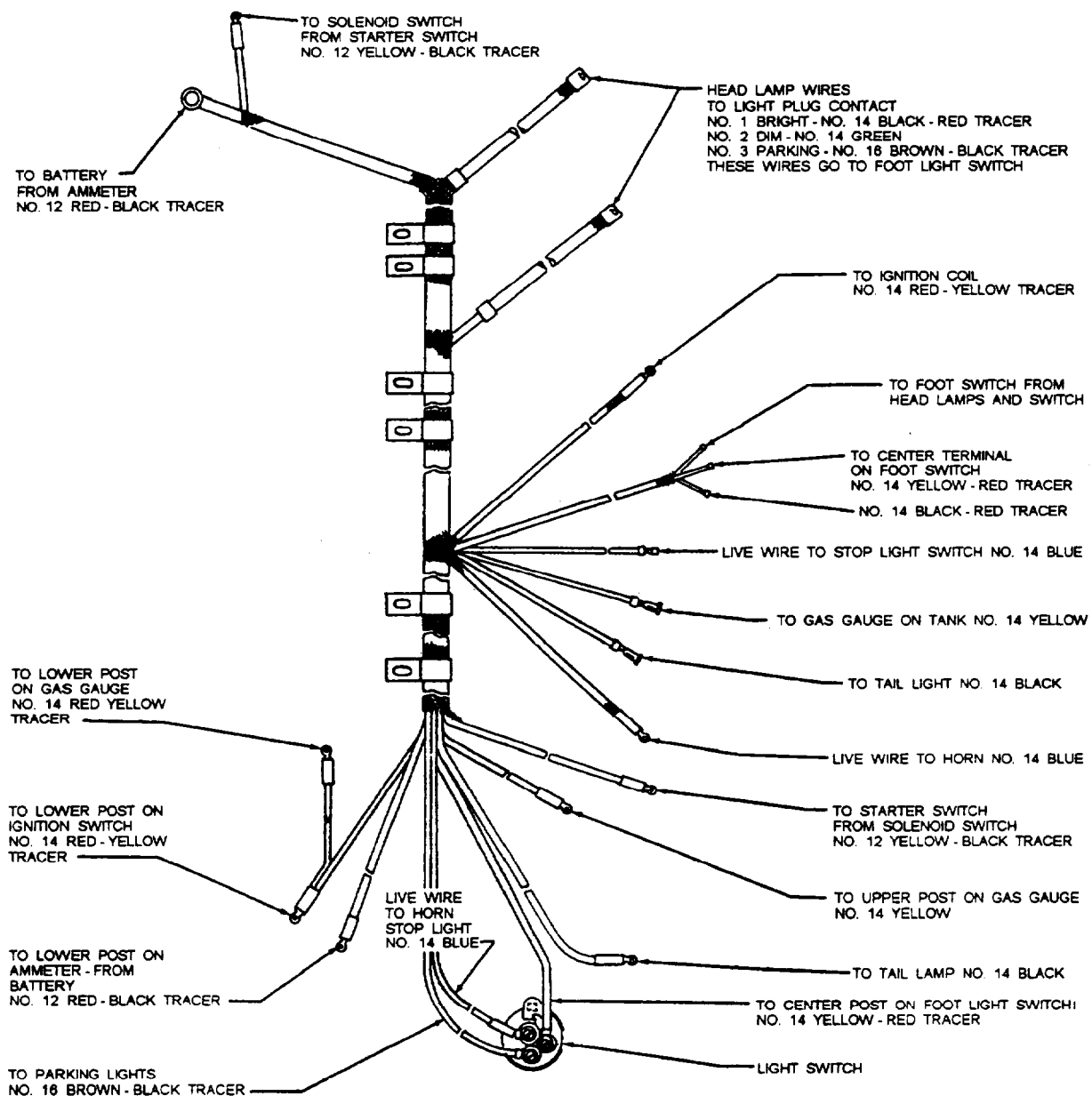

CMB2F238

Figure 2-86.—A typical wiring harness.

Wiring color codes are used by manufacturers to assist the mechanics in identifying the wires used in many circuits and making repairs in a minimum of time. No color code is common to all manufacturers. For this reason, the manufacturer's service manual is a must for speedy troubleshooting and repairs.

Wiring found on tactical equipment (M-series) has no color. All the wires used on these vehicles are black. Small metal tags (fig. 2-87), stamped with numbers or

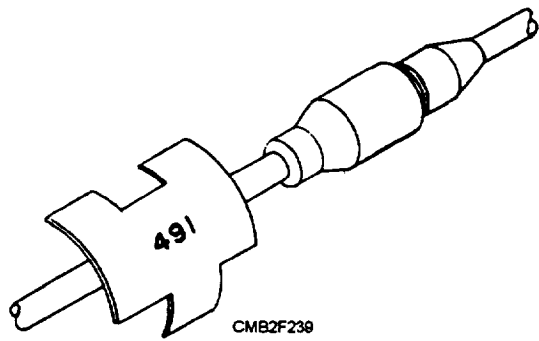

Figure 2-87.—Metal tag wire identification.

codes, are used to identify the wiring illustrated by diagrams in the technical manuals. These tags are securely fastened near the end of individual wires.

## WIRING DIAGRAMS

Wiring diagrams (fig. 2-88) are drawings that show the relationship of the electrical components and wires in a circuit. They seldom show the routing of the wires within the electrical system of the vehicle.

Often you will find ELECTRICAL SYMBOLS used in wiring diagrams to simulate individual components. Figure 2-89 shows some of the symbols you may encounter when tracing individual circuits in a wiring diagram.

## WIRE TERMINAL ENDS

Wire terminals are divided into two major classes—the solder type and the solderless type, which is also known as the pressure or crimp type. The solder

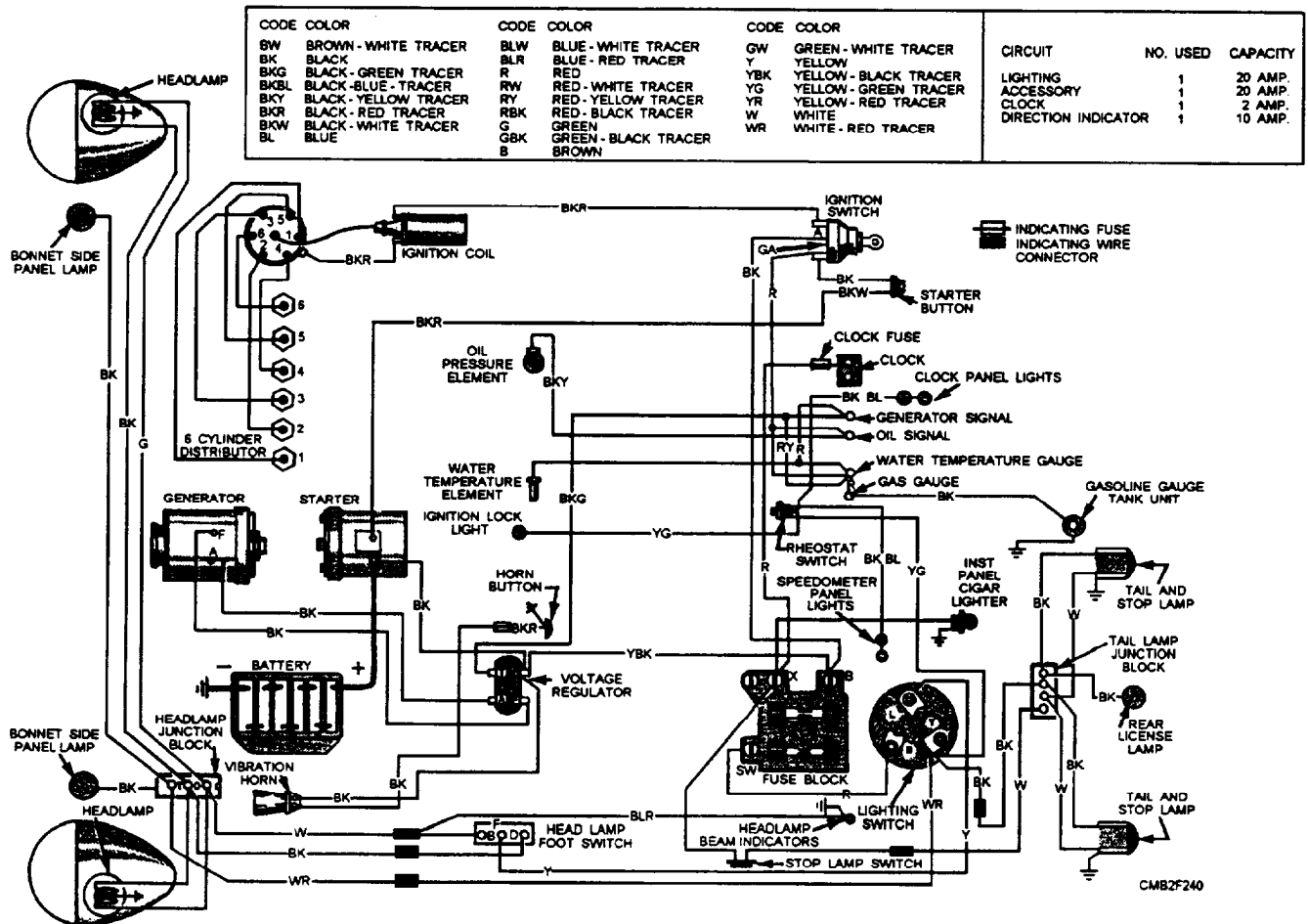
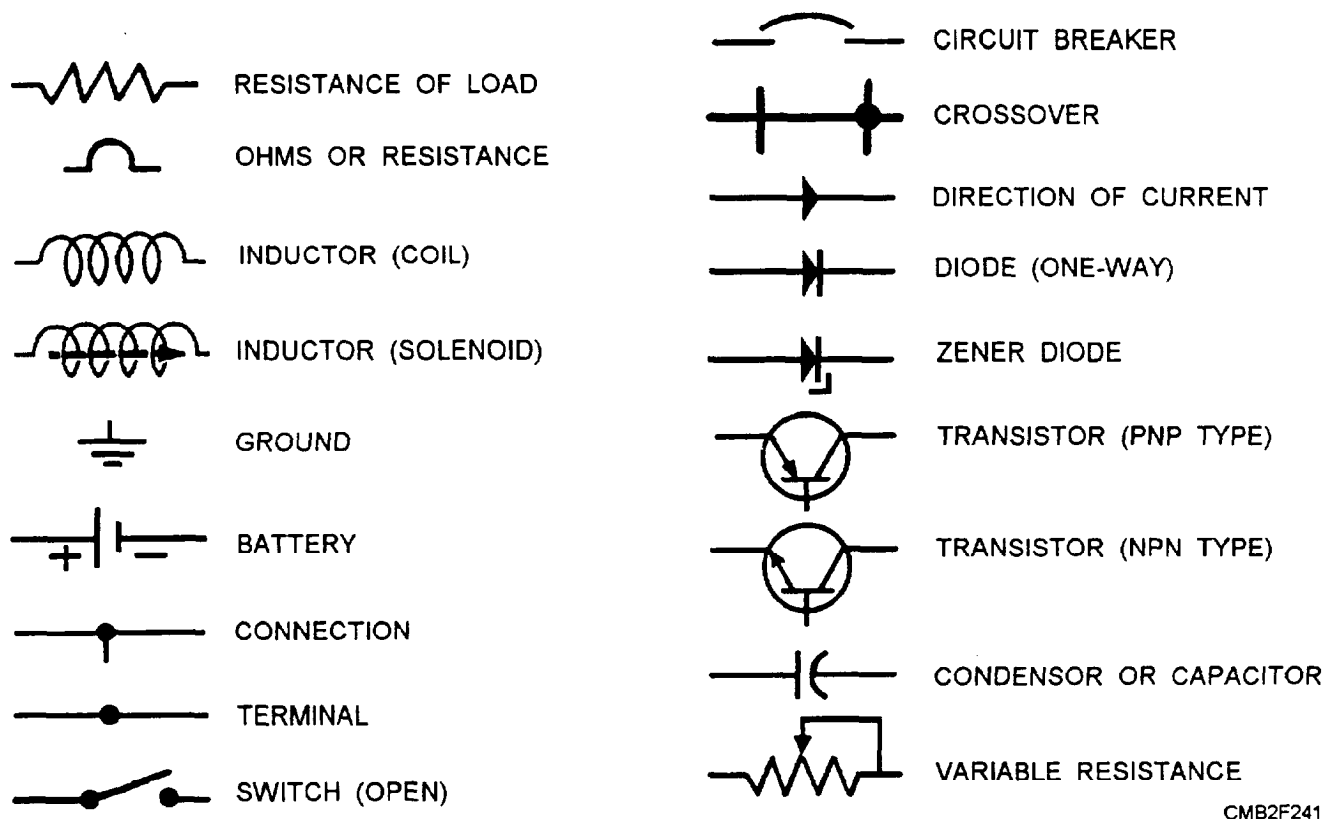

Figure 2-88.—Wiring diagram of a passenger vehicle showing standard equipment and color code for wires.



CMB2F241

Figure 2-89.—Wiring diagram symbols.

type has a cup in which the wire is held by solder permanently. The solderless type is connected to the wire by special tools. These tools deform the barrel of the terminal and exert pressure on the wire to form a strong mechanical bond and electrical connection. Solderless type terminals are gradually replacing solder type terminals in military equipment.

### WIRE SUPPORT AND PROTECTION

Wire in the electrical system should be supported by clamps or fastened by wire ties at various points about the vehicle. When installing new wiring, be sure to keep it away from any heat-producing component that would scorch or bum the insulation.

Wire passing through holes in the metal members of the frame or body should be protected by rubber grommets. If rubber grommets are not available, use a piece of rubber hose the size of the hole to protect the wiring from chafing or cutting on sharp edges.

### REVIEW 6 QUESTIONS

- Q1. What type of wire circuit is commonly used on equipment that is subject to heavy vibrations?
- Q2. What are the two types of wiring assemblies?
- Q3. On tactical equipment that has no color-coded wiring, how are the wires identified?

## **REVIEW 1 ANSWERS**

- Q1. Five*
- Q2. Battery*
- Q3. Lead peroxide*
- Q4. Hydrogen*
- Q5. 1.28*
- Q6. Cold-cranking rating and reserve capacity rating*
- Q7. Always pour acid into water*
- Q8. Battery leakage test*
- Q9. Zero*
- Q10. 3 minutes*
- Q11. A and B circuits*
- Q12. Speed of armature rotation, number of armature conductors, and the strength of the magnetic field*
- Q13. Growler test and bar-to-bar test*
- Q14. Rectifier assembly*
- Q15. Delta type*
- Q16. The regulator increases resistance between the battery and the rotor windings of the alternator*
- Q17. Integral regulator*
- Q18. Regulator voltage test*
- Q19. Load tester and volt-ohm-millimeter (multimeter)*
- Q20. Direct battery voltage*

## **REVIEW 2 ANSWERS**

- Q1. Bendix drive, overrunning clutch, and Dyer drive*
- Q2. Makes and break-s the electrical connection*
- Q3. Low battery voltage*
- Q4. Double reduction starter*
- Q5. False*
- Q6. 30 seconds*
- Q7. Insulated circuit resistance test*

### **REVIEW 3 ANSWERS**

- Q1. Primary circuit*
- Q2. Ignition coil*
- Q3. Resistor and non-resistor types*
- Q4. The length and diameter of the insulator tip and the ability of the sparkplug to transfer heat to the cooling system*
- Q5. False*
- Q6. Point dwell*
- Q7. Distributor cam*
- Q8. Detonation sensor*
- Q9. Sparkplug leakage*
- Q10. More than 3 degrees*
- Q11. Non-magnetic feeler gauge*
- Q12. Timing is too retarded*
- Q13. Base timing*

### **REVIEW 3 ANSWERS**

- Q1. 25 percent*
- Q2. Rheostat*
- Q3. 25 feet*
- Q4. 400 feet*
- Q5. On the brake pedal*

### **REVIEW 5 ANSWERS**

- Q1. Voltmeter*
- Q2. By dividing the available voltage between two electrically heated bimetallic strips*
- Q3. Distributor*
- Q4. Faulty horn switch*

### **REVIEW 6 ANSWERS**

- Q1. Two-wire circuit*
- Q2. Cables and harnesses*
- Q3. Small metal tags with numbers*

## CHAPTER 3

# HYDRAULIC AND PNEUMATIC SYSTEMS

### INTRODUCTION

**Learning Objective:** Explain the operating principles of hydraulic and pneumatic systems. Identify the components, component functions, and maintenance procedures of hydraulic and pneumatic systems.

In automotive and construction equipment, the terms *hydraulic* and *pneumatic* describe a method of transmitting power from one place to another through the use of a liquid or a gas. Certain physical laws or principles apply to all liquids and gases. You should be familiar with the following terms, as they are associated with hydraulic and pneumatic systems.

- **HYDRAULICS** is a branch of science that deals with the study and use of liquids as related to the mechanical aspects of physics.
- **PNEUMATICS** is a branch of science that deals with the study and use of air and other gases as related to the mechanical aspects of physics.

The chapter covers the basic principles associated with hydraulics and pneumatics, followed by coverage of various system components. The purpose of this information is to give you an analytical understanding of the interrelationships of principles and the components in an operating system.

### HYDRAULIC SYSTEMS

**Learning Objective:** Identify operational characteristics, component functions, and maintenance procedures of a hydraulic system.

The extensive use of hydraulics to transmit power is due to the fact that a properly constructed hydraulic system possesses a number of favorable characteristics. These are as follows:

- Eliminates the need for complicated systems using gears, cams, and levers.
- Motion can be transmitted without the slack inherent in the use of solid machine parts.
- The fluids used are not subject to breakage as are mechanical parts.
- Hydraulic system mechanisms are not subjected to great wear.

If the system is well-adapted to the work it is required to perform and not misused, it can provide smooth, flexible, uniform action without vibration and is unaffected by variation of load. Hydraulic systems can provide widely variable motions in both rotary and straight-line transmission of power. The need for control by hand can be minimized. In addition, they are economical to operate.

### BASIC PRINCIPLES OF HYDRAULICS

The basic principles of hydraulics are few and simple and are as follows:

- Liquids have no shape of their own.
- Liquids will **NOT** compress.
- Liquids transmit applied pressure in all directions.
- Liquids provide great increase in work force.

### Pressure and Force

The terms *force* and *pressure* are used extensively in the study of fluid power. It is essential that we distinguish between these terms. Force means a total push or pull. It is push or pull exerted against the total area of a particular surface and is expressed in pounds or grams. Pressure means the amount of push or pull (force) applied to each unit area of the surface and is expressed in pounds per square inch ( $\text{lb/in}^2$ ) or grams per square centimeter ( $\text{gm/cm}^2$ ). Pressure may be exerted in one direction, in several directions, or in all directions.

### Computing Force, Pressure, and Area

A formula is used in computing force, pressure, and area in hydraulic systems. In this formula, P refers to pressure, F indicates force, and A represents area.

Force equals pressure times area. Thus, the formula is written  $F = P \times A$

Pressure equals force divided by area. By rearranging the above formula, this state may be condensed into the following:  $P = F$  divided by  $A$ .

Since area equals force divided by pressure, the formula for area is written as follows:  $A = F$  divided by  $P$

Figure 3-1 shows a memory device for recalling the different variations of the formula. Any letter in the triangle may be expressed as the product or quotient of the other two, depending on its position within the triangle.

### Incompressibility and Expansion of Liquids

For all practical purposes, fluids are incompressible. Under extremely high pressures: the volume of a fluid can be decreased somewhat, though the decrease is so slight that it is considered to be negligible except by design engineers.

Liquids expand and contract because of temperature changes. When liquid in a closed container is subjected to high temperatures, it expands and this exerts pressure on the walls of the container; therefore, it is necessary that pressure-relief mechanisms and expansion chambers be incorporated into hydraulic systems. Without these precautionary measures, the expanding fluid could exert enough pressure to rupture the system.

### Transmission of Forces through Liquids

When the end of a solid bar is struck, the main force of the blow is carried straight through the bar to the other end (fig. 3-2, view A). This happens because the bar is rigid. The direction of the blow almost entirely determines the direction of the transmitted force. The more rigid the bar, the less force is lost inside the bar or transmitted outward at right angles to the direction of the blow.

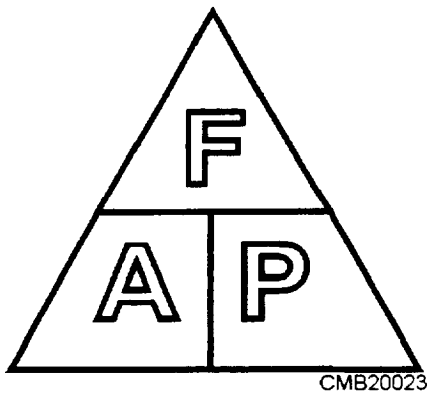

Figure 3-1.—Device for determining the arrangement of the force, pressure, and area formula.

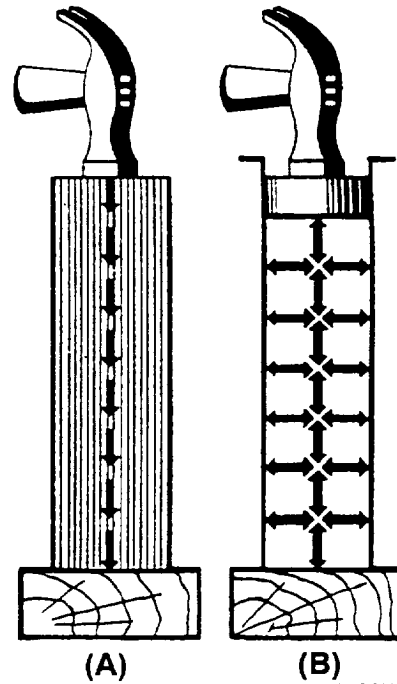

Figure 3-2.—Transmission of force: (A) Solid; (B) Fluid.

When a force is applied to the end of a column of confined liquid (fig. 3-2, view B), it is transmitted straight through the other end and also undiminished in every direction throughout the column—forward, backward, and sideways—so that the containing vessel is literally tilled with pressure.

An example of this distribution of force is shown in figure 3-3. The flat hose takes on a circular cross section when it is filled with water under pressure. The outward push of the water is equal in every direction.

### Pascal's Law

The foundation of modern hydraulics was established when Blaise Pascal, a French scientist,

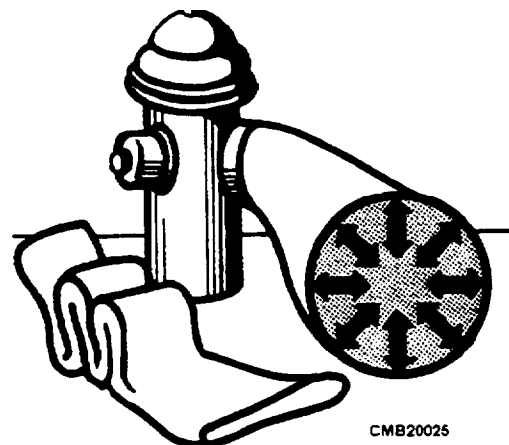

Figure 3-3.—Distribution of force.



discovered the fundamental law for the science of hydraulics. Pascal's law tells us that **pressure on a confined fluid is transmitted undiminished in every direction, and acts with equal force on equal areas, throughout the confining vessel or system.**

According to Pascal's law, any force applied to a confined fluid is transmitted in all directions throughout the fluid regardless of the shape of the container. Consider the effect of this in the systems shown in views A and B of figure 3-4. If there is resistance on the output piston (view A, piston 2) and the input piston is pushed downward, a pressure is created through the fluid which acts equally at right angles to surfaces in all parts of the container.

If the force 1 is 100 pounds and the area of input piston 1 is 10 square inches, then pressure in the fluid is 10 psi ( $100 \div 10$ ). It must be emphasized that this fluid pressure cannot be created without resistance to flow, which, in this case, is provided by the 100-pound force acting against the top of the output piston 2. This pressure acts on piston 2, so for each square inch of its area, it is pushed upward with the force of 10 pounds. In this case, a fluid column of a uniform cross section is considered so the area of output piston 2 is the same as input piston 1, or 10 square inches; therefore, the upward force on output piston 2 is 100 pounds—the same as was applied to input piston 1. All that has been accomplished in this system was to transmit the 100-pound force around a bend; however, this principle underlies practically all-mechanical applications of fluid power.

At this point, it should be noted that since Pascal's law is independent of the shape of the container, it is not necessary that the tubing connecting the two pistons should be the full area of the pistons. A connection of any size, shape, or length will do so long as an unobstructed passage is provided. Therefore, the system shown in view B of figure 3-4 (a relatively small, bent pipe connects the two cylinders) will act the same as that shown in view A.

### Multiplication of Forces

Some hydraulic systems are used to multiply force. In figure 3-5, notice that piston 1 is smaller than piston 2. Assume that the area of the input piston 1 is 2 square inches. With a resistant force on piston 2, a downward force of 20 pounds acting on piston 1 creates 10 psi ( $20 \div 2$ ) in the fluid. Although this force is much smaller than the applied forces in figure 3-4,

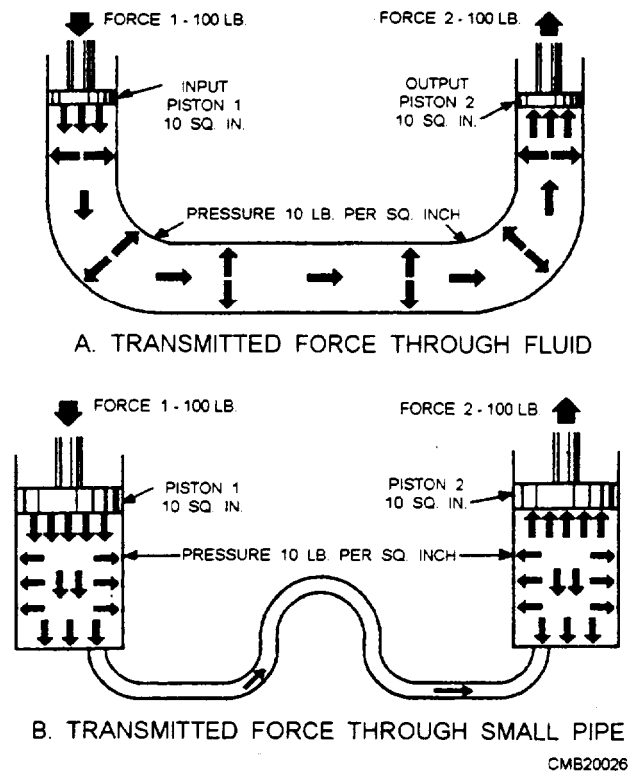

Figure 3-4.—Force transmitted from piston to piston.

the pressure is the same because the force is concentrated on a relatively small area.

This pressure of 10 psi acts on all parts of the fluid container, including the bottom of output piston 2; therefore, the upward force on output piston 2 is 10 pounds for each of its 20 square inches of area, or 200 pounds ( $10 \times 20$ ). In this case, the original force has been multiplied tenfold while using the same pressure in the fluid as before. In any system with these dimensions, the ratio of output force to input force is always 10 to 1 regardless of the applied force; for example, if the applied force of input piston 1 is 50 pounds, the pressure in the system is increased to 25 psi. This will support a resistant force of 500 pounds on output piston 2.

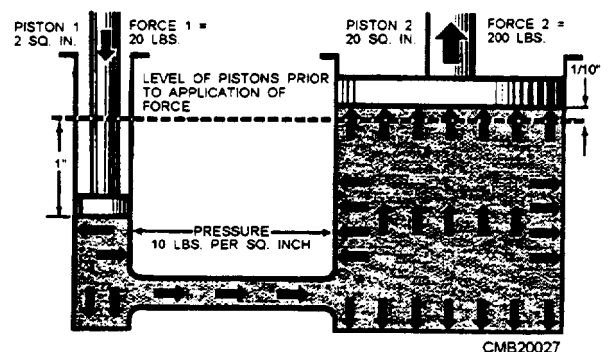

Figure 3-5.—Multiplication of force in a hydraulic system.

The system works the same in reverse. Consider piston 2 as the input and piston 1 as the output; then the output force will always be one tenth of the input force.

Therefore, the first basic rule for two pistons used in a fluid power system is **the force acting on each is directly proportional to its area, and the magnitude of each force is the product of the pressure and its area is totally applicable.**

### Volume and Distance Factors

In the systems shown in views A and B of figure 3-4, the pistons have areas of 10 square inches. Since the areas of the input and output pistons are equal, a force of 100 pounds on the input piston will support a resistant force of 100 pounds on the output piston. At this point the pressure of the fluid is 10 psi. A slight force in excess of 100 pounds on the input piston will increase the pressure of the fluid, which, in turn, overcomes the resistance force. Assume that the output piston is forced downward 1 inch. This action displaces 10 cubic inches of fluid (1 in. x 10 sq. in. = 10 cubic inches). Since liquid is practically incompressible, this volume must go some place. This volume of fluid moves the output piston. Since the area of the output piston is likewise 10 square inches, it moves 1 inch upward to accommodate the 10 cubic inches of fluid. The pistons are of equal areas; therefore, they will move the same distance, though in opposite directions.

Applying this reasoning to the system in figure 3-5, it is obvious that if the input piston 1 is pushed down 1 inch, only 2 cubic inches of fluid is displaced. The output piston 2 will move only one tenth of an inch to accommodate these 2 cubic inches of fluid, because its area is 10 times that of input piston 1. This leads to the second basic rule for two pistons in the same fluid power system. which is **the distances moved are inversely proportional to their areas.**

While the terms and principles mentioned above are not all that apply to the physics of fluids, they are sufficient to allow further discussion in this training manual (TRAMAN). The TRAMAN, *Fluid Power*, NAVEDTRA 12964, should be obtained and studied for more comprehensive coverage of this subject.

### TYPES OF HYDRAULIC FLUIDS

There have been many liquids tested for use in hydraulic systems. Currently liquids being tested include mineral oil, water, phosphate ester, water-based ethylene glycol compounds, and silicone fluids. The three most common types of hydraulic fluids are

petroleum-based, synthetic fire-resistant, and water-based fire-resistant.

#### Petroleum-Based Fluids

The most common hydraulic fluids used in hydraulic systems are the petroleum-based oils. These fluids contain additives to protect the fluid from oxidation, to protect the metals from corrosion, to reduce the tendency of the fluid to foam, and to improve the viscosity.

#### Synthetic Fire-Resistant Fluids

Petroleum-based oils contain most of the desired traits of a hydraulic fluid. However, they are flammable under normal conditions and can become explosive when subjected to high pressures and a source of flame or high temperatures. Nonflammable synthetic liquids have been developed for use in hydraulic systems where fire hazards exist. These synthetic fire-resistant fluids are phosphate ester fire-resistant fluid, silicone synthetic fire-resistant fluid, and the lightweight synthetic fire-resistant fluid.

#### Water-Based Fire-Resistant Fluids

The most widely used water-based hydraulic fluids may be classified as water-glycol mixtures and water-synthetic base mixtures. The water-glycol mixture contains additives to protect it from oxidation, corrosion, and biological growth and to enhance its load-carrying capacity.

Fire resistance of the water mixture depends on the vaporization and smothering effect of steam generated from the water. The water in water-based fluids is constantly being driven off while the system is operating. Therefore, frequent checks are required to maintain the correct ratio of water to base mixture.

### HYDRAULIC SYSTEM COMPONENTS

An arrangement of interconnected components is required to transmit and control power through pressurized fluid. Such an arrangement is commonly referred to as a system. The number and arrangement of the components vary from system to system, depending on application. In many applications, one main system supplies power to several subsystems, which are commonly referred to as circuits. The complete system may be a small compact unit; more often, however, the components are located at widely separated points for convenient control.

The basic components of a fluid power system are essentially the same, regardless of whether the system

uses hydraulic or pneumatic medium. The basic components are as follows:

- Reservoir
- Strainers and filters
- Pumps
- Control valves (directional and relief)
- Actuating devices (cylinders)
- Accumulators
- Motors
- Lines (pipe, tubing, or flexible hose)
- Connectors and fittings
- Sealing materials and devices

Several applications of fluid power require only a simple system; that is, a system which uses only a few components in addition to the basic components.

### Reservoir

A properly constructed reservoir (fig. 3-6) is more than just a tank to hold oil until the system demands fluid. It should also be capable of the following:

1. Dissipating heat from the fluid,

2. Separating air from the oil, and
3. Settling out contamination in the oil.

Ideally, the reservoir should be high and narrow, rather than shallow and broad. The oil level should be as high as possible above the opening to the pump suction line. This condition prevents the vacuum at the line opening from causing a vortex or whirlpool effect. Anytime you see a whirlpool at the suction line opening, the system is taking in air.

As a rule of thumb, the reservoir level should be two to three times the pump output per minute. By this rule which works well for stationary machinery, a 20-gpm system would require a 40- or 60-gpm reservoir. However, this is not possible for mobile equipment. You are more likely to find a 20- or 30-gallon tank to support a 100-gpm system. This is possible because mobile systems operate intermittently, rather than all the time. The largest reservoirs are on mobile equipment. These reservoirs may have a 40- or 50-gallon capacity, capable of handling more than 200-gpm output.

The reservoir must be sized to ensure there is a reserve of oil with all the cylinders in the system fully extended. The reserve must be high enough to prevent a whirlpool at the suction line opening. Also, there

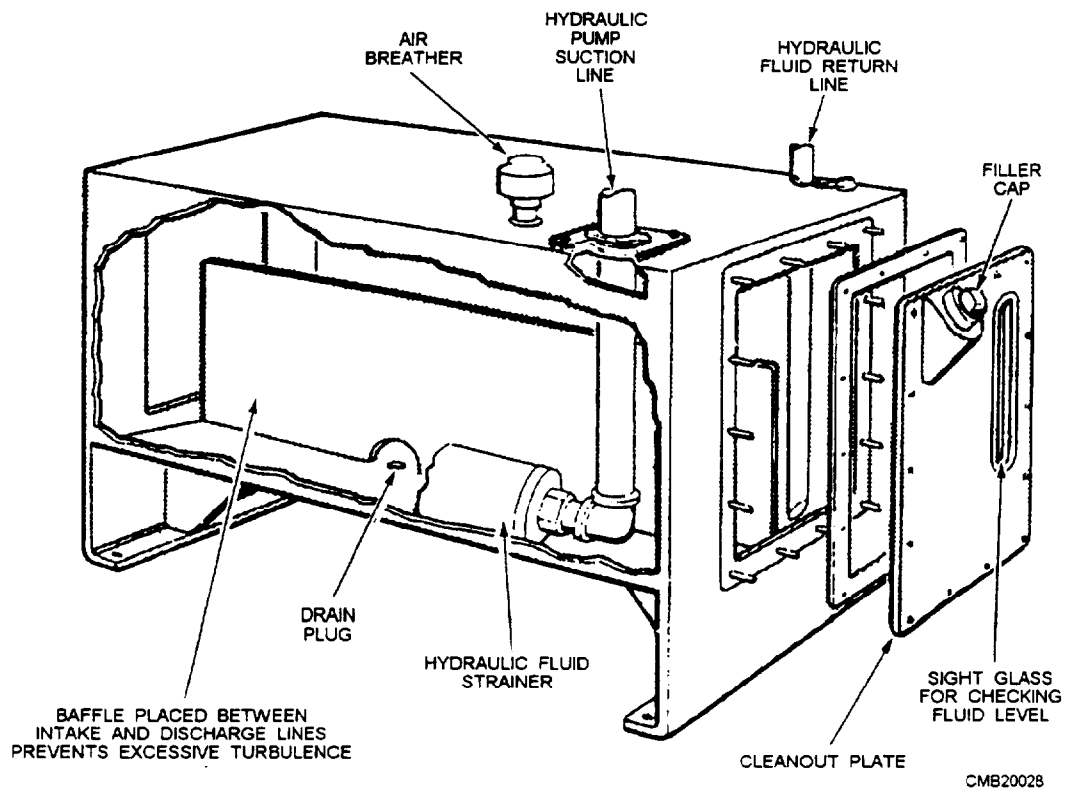

Figure 3-6.—Typical hydraulic reservoir.

must be enough space to hold all the oil when the cylinders retract with some space to spare for expansion of hot oil.

An air vent allows the air to be drawn in and pushed out of the reservoir by the ever-changing fluid level. An air filter is attached to the air vent to prevent drawing atmospheric dust into the system by the ever-changing fluid level. A firmly secured filling strainer of fine mesh wire is always placed below the filler cap.

The sight gauge is provided so the normal fluid level can always be seen, as it is essential that the fluid in the reservoir be at the correct level. The baffle plate segregates the outlet fluid from the inlet fluid. Although not a total segregation, it does allow time to dissipate the air bubbles, lessen the fluid turbulence (contaminants settle out of nonturbulent fluid), and cool the return fluid somewhat before it is picked up by the pump.

Reservoirs used on CESE may vary considerably from that shown in figure 3-6; however, manufacturers retain many of the noted features as possible depending on design limits and use.

### **Strainers and Filters**

Strainers are constructed of fine mesh wire screens or of screening elements, consisting of specially processed wire of varying thickness wrapped around metal frames. They do **NOT** provide as fine a screening action as filters, but they offer less resistance to flow and are used in pump suction lines where pressure drop must be kept to a minimum. If one strainer is not large enough to handle the supply of the pump, two or more strainers can be used in parallel.

The most common device installed in hydraulic systems to prevent foreign particles and contamination from remaining in the system are called filters. They may be located in the reservoir, in the return line, in the pressure line, or any other location in the system where the designer of the system decides they are needed to safeguard the system against impurities.

Filters are classified as full flow and partial flow. In the full-flow filter, all fluid that enters the unit passes through the filtering element, while in the partial-flow filter, only a portion of the fluid passes through the element.

### **Pumps**

The purpose of a hydraulic pump is to supply a flow of fluid to a hydraulic system. The pump does not

create system pressure, since only a resistance to the flow can create pressure. As the pump provides flow, it transmits a force to the fluid. As the fluid flow encounters resistance, this force is changed into pressure. Resistance to flow is the result of a resistance or obstruction in the path of flow. This restriction is normally the work accomplished by the hydraulic system, but can also be restrictions of lines, fittings, and valves within the system. Thus the load imposed on the system or action of a pressure-regulating device controls the pressure.

Pumps are rated according to their volumetric output and displacement. Volumetric output is the amount of fluid a pump can deliver to its outlet port in a certain period of time at a given speed. Volumetric output is usually expressed in gallons per minute (gpm). Since changes in pump speed affect volumetric output, some pumps are rated by their displacement. Pump displacement is the amount of fluid the pump can deliver per cycle. Since most pumps use a rotary drive, displacement is usually expressed in terms of cubic inches per revolution.

Many different methods are used to classify pumps. Terms, such as nonpositive displacement, positive displacement, fixed displacement, variable displacement, fixed delivery, variable delivery, constant volume, and others are used to describe pumps. The first two of these terms describe the fundamental division of pumps because all pumps are either nonpositive displacement or positive displacement. Basically pumps that discharge liquid in a continuous flow are referred to as nonpositive displacement, and those that discharge volumes separated by a period of no discharge are referred to as positive displacement.

Pumps may also be classified according to the specific design used to create the flow of fluid. Practically all-hydraulic pumps fall within three designs classifications—centrifugal, rotary, and reciprocating. Since the use of centrifugal pumps is limited, we will only discuss rotary and reciprocating.

**ROTARY PUMPS.**—All rotary pumps have rotating parts that trap the fluid at the inlet (suction) port and force it through the discharge port into the system. Gears (figs. 3-7, 3-8, and 3-9), screws (fig. 3-10), lobes (fig. 3-11), and vanes (fig. 3-12) are commonly used to move the fluid. Rotary pumps are positive displacement of the fixed displacement type.

Rotary pumps are designed with very small clearances between rotating parts and stationary parts

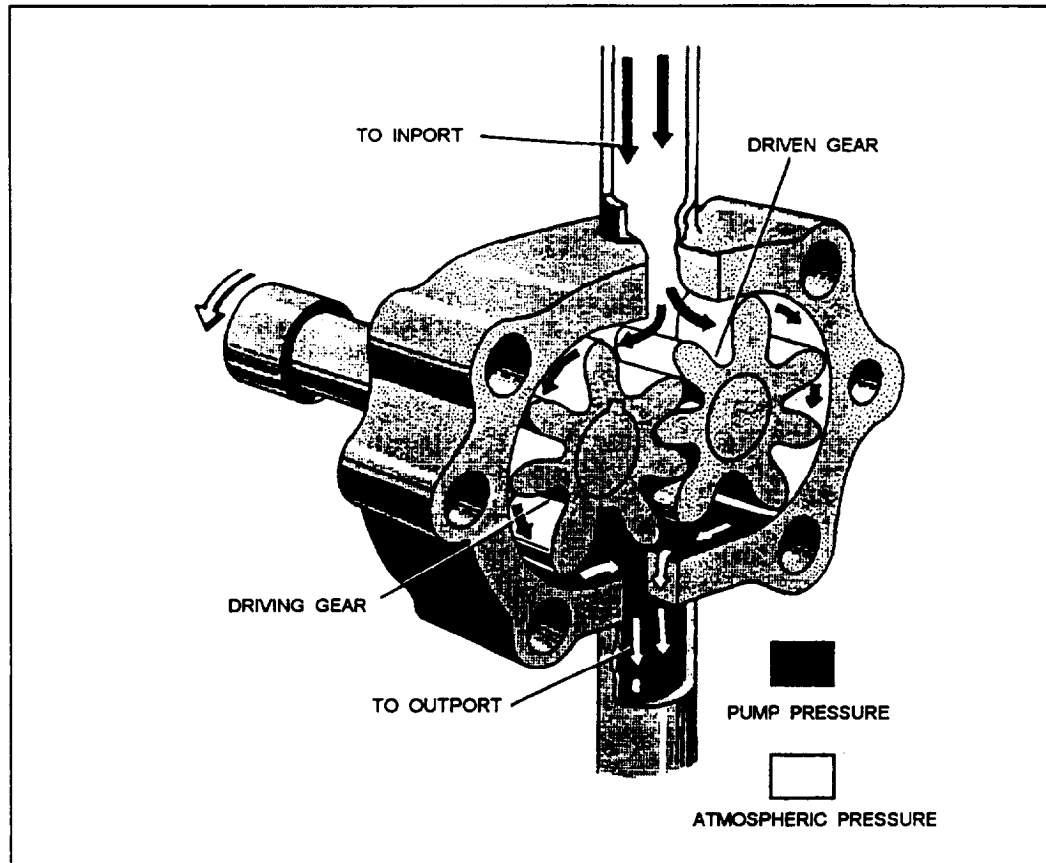

CMB20029

Figure 3-7.—Gear-type rotary pump.

to minimize slippage from the discharge side back to the suction side. They are designed to operate at relatively moderate speeds. Operating at high speeds causes erosion and excessive wear which results in increased clearances.

There are numerous types of rotary pumps and various methods of classification. They may be classified by shaft position—either vertically or horizontally mounted; the type of drive—electric motor, gasoline engine, and so forth; their manufacturer's name; or service application. However, classification of rotary pumps is generally made according to the type of rotating element.

**RECIPROCATING PUMPS.**—The term *reciprocating* is defined as back-and-forth motion. In a reciprocating pump, it is the back-and-forth motion of pistons inside of cylinders that provides the flow of fluid. Reciprocating pumps, like rotary pumps, operate on the positive principle; that is, each stroke delivers a definite volume of liquid to the system.

The most common type of reciprocating pump is the hand pump (fig. 3-13). There are two types of manually operated reciprocating pumps—single action and double action. The single-action pump

provides flow during every other stroke, while the double-action provides flow during each stroke. Single-action pumps are frequently used in hydraulic jacks.

Several types of power-operated hydraulic pumps, such as the radial piston (fig. 3-14) and axial piston (figs. 3-15 and 3-16), are classified as reciprocating pumps. These pumps are sometimes classified as rotary pumps, because a rotary motion is imparted to the pumps by the source of power. However, the actual pumping is performed by sets of pistons reciprocating inside sets of cylinders.

### Control Valves

It is all but impossible to design a practical fluid power system without some means of controlling the volume and pressure of the fluid and directing the flow of fluid to the operating units. This is accomplished by incorporating different types of valves. A *valve* is defined as any device by which the flow of fluid may be started, stopped, or regulated by a movable part that opens or obstructs passage.

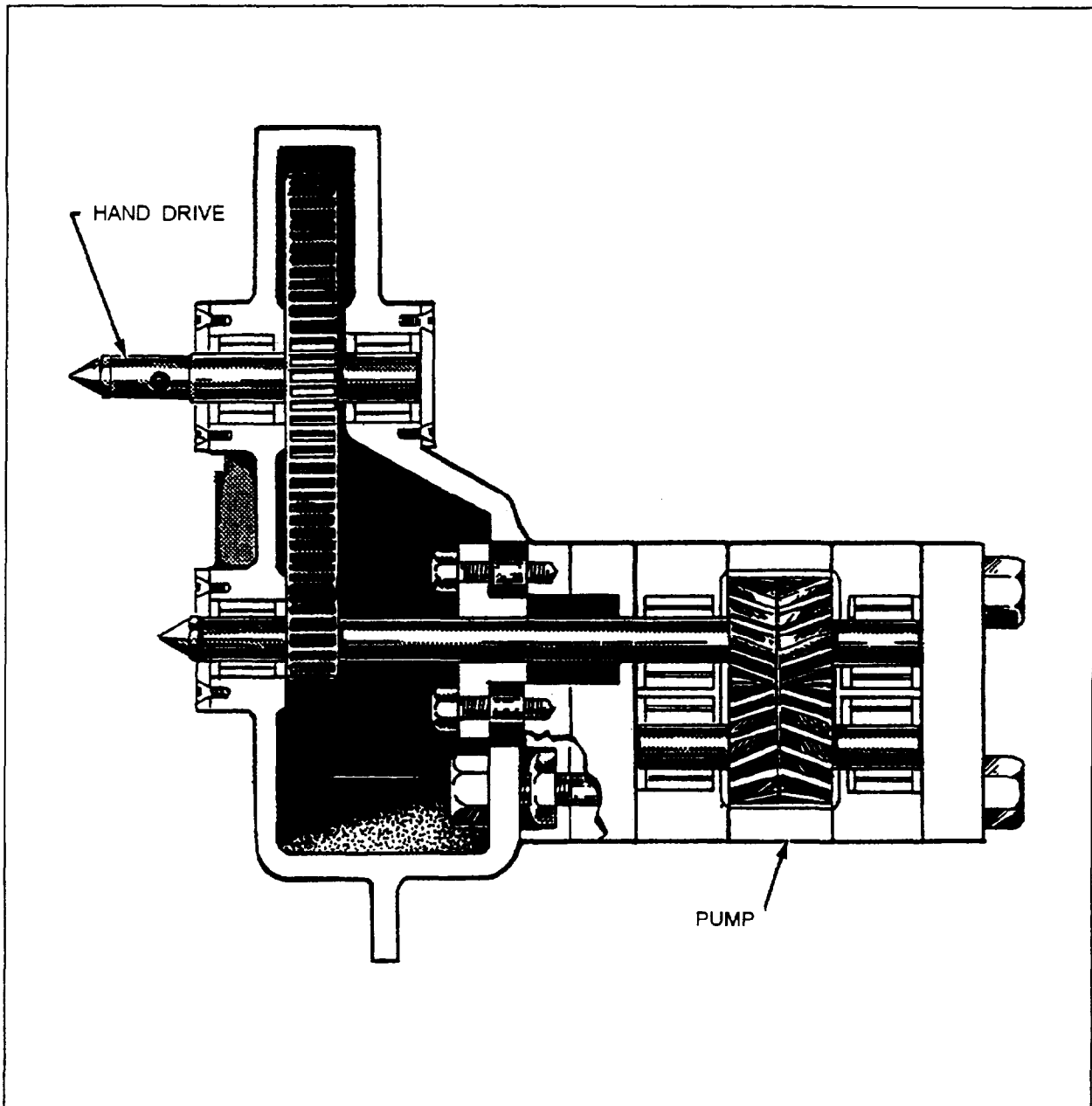

CMB20030

Figure 3-8.—Herringbone gear pump.

Valves must be accurate in the control of fluid flow and pressure and the sequence of operation. Leakage between the valve element and the valve seat is reduced to a negligible quantity by precision-machined surfaces, resulting in carefully controlled clearances. This is one of the very important reasons for minimizing contamination in the system. Contamination causes valves to stick, plugs small orifices, and causes abrasions of the valve seating surfaces which will result in leakage between the valve element and valve seat when the valve is closed. Any of these can result in inefficient operation or complete stoppage of the equipment.

Valves may be controlled manually, electrically, pneumatically, mechanically, hydraulically, or by combinations of two or more methods. Factors that determine the method of control include the purpose of the valve, the design and purpose of the system, the location of the valve within the system, and the availability of the source of power.

Valves are classified according to their use: flow control, pressure control, and directional control. Some of these valves have multiple functions that fall into more than one classification.

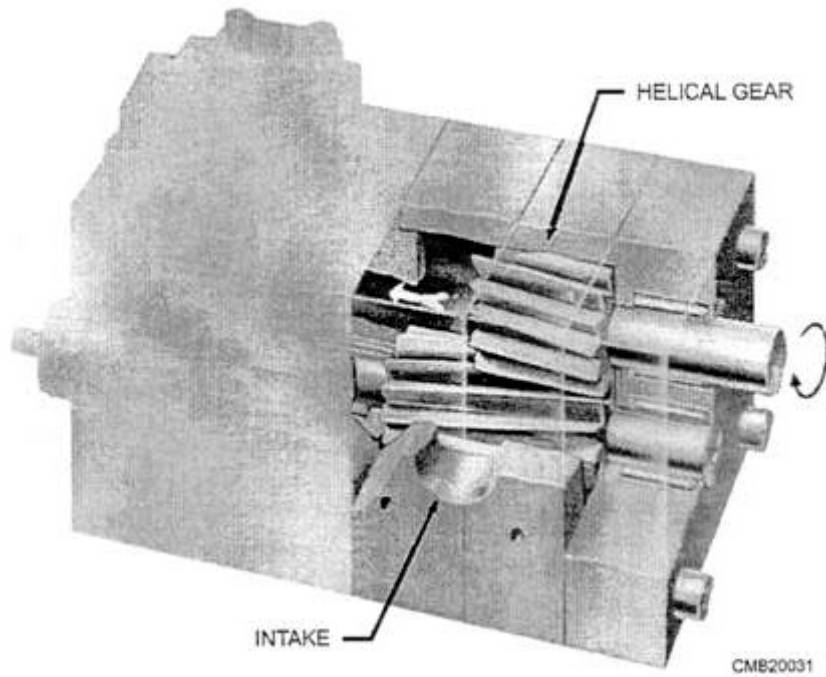

Figure 3-9.—Helical gear pump.

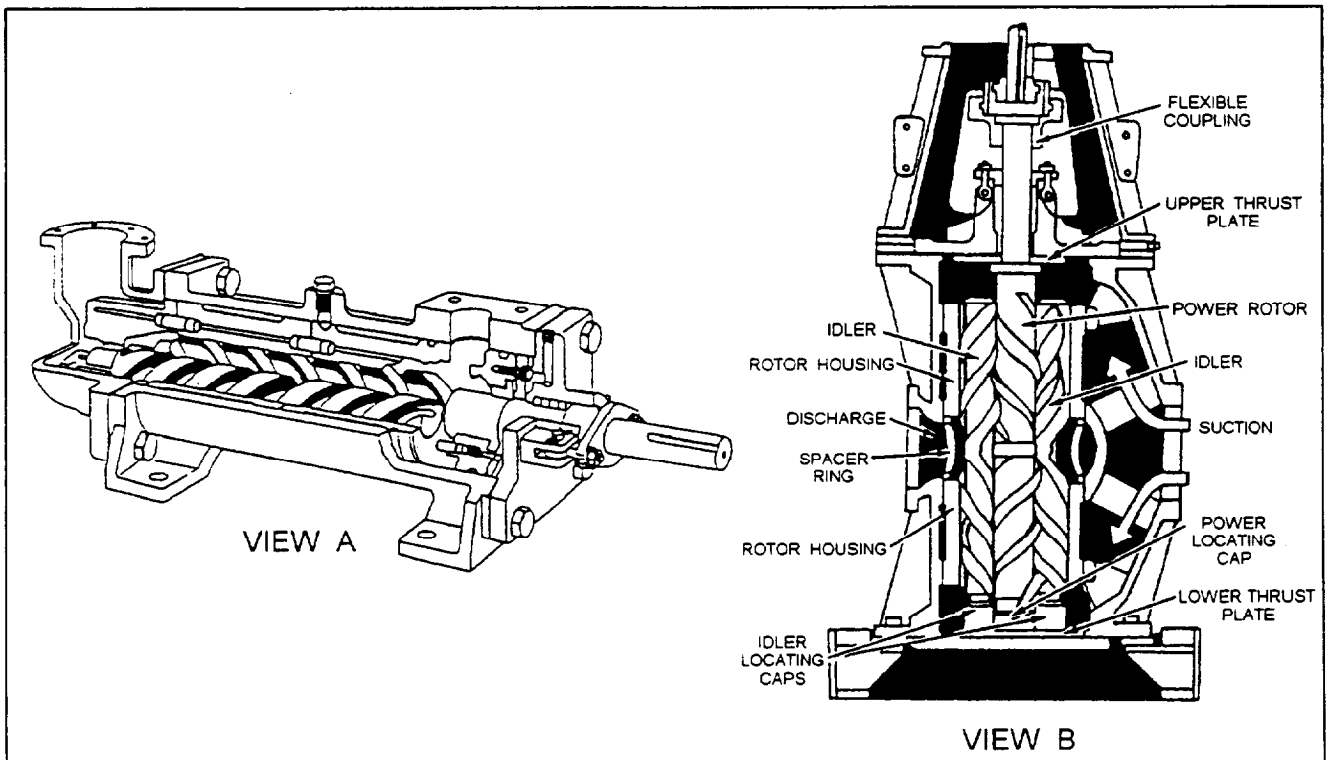

Figure 3-10.—Screw pump.

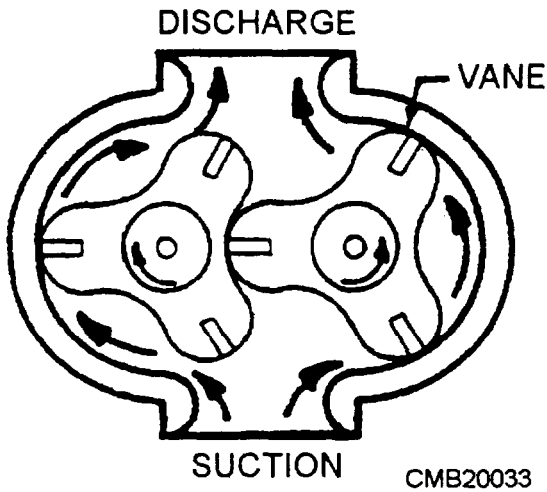

Figure 3-11.—Lobe pump.

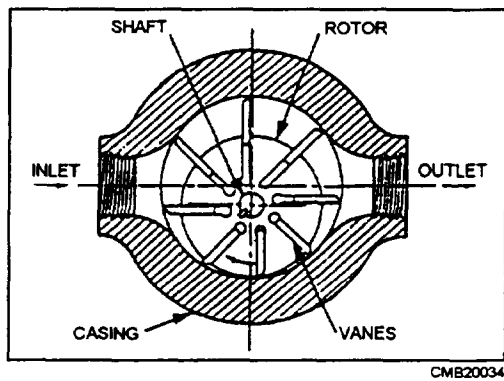

Figure 3-12.—Vane pump.

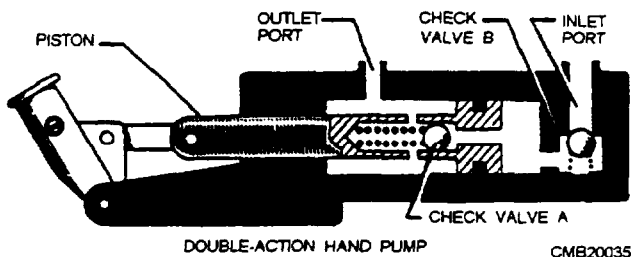

Figure 3-13.—Hydraulic hand pump.

**FLOW CONTROL VALVES.**—Flow control valves are used to regulate the flow of fluid in a fluid-power system. Control of flow in fluid-power systems is important because the rate of movement of fluid-powered mechanisms depends on the rate of flow of the pressurized fluid. Some of the most commonly used flow control valves are ball valves (fig. 3-17), gate valves (fig. 3-18), globe valves (fig. 3-19), and needle valves (fig. 3-20).

**PRESSURE CONTROL VALVES.**—The safe and efficient operation of hydraulic systems, systems components, and related equipment requires a means

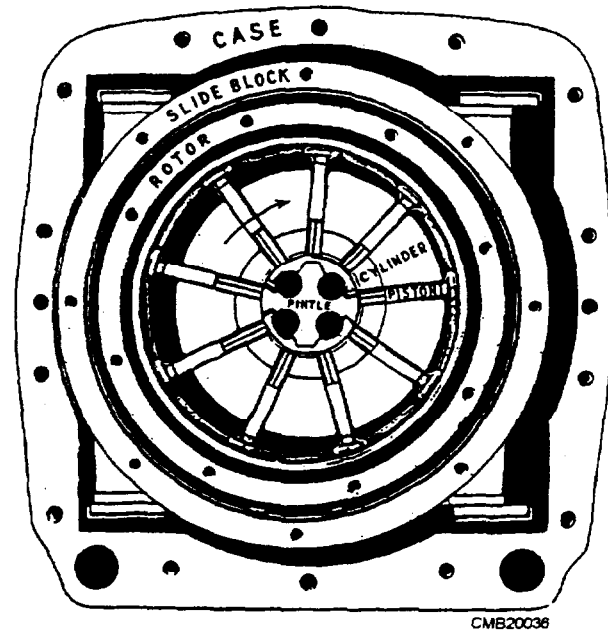

Figure 3-14.—Nine-piston radial piston pump.

of controlling pressure. There are many types of automatic pressure control valves. Some of them merely provide an escape for pressure that exceeds a set pressure, some only reduce the pressure to a lower pressure system or subsystem, and some keep the pressure in a system within a required range. The most common pressure control valves are relief valves (fig. 3-21), pressure regulators (fig. 3-22), pressure-reducing valves (fig. 3-23), and counterbalance valves (fig. 3-24).

**DIRECTIONAL CONTROL VALVES.**—

Directional control valves are designed to direct the flow of fluid, at the desired time, to the point in a fluid power system where it will do work; for example, using a directional control valve to drive a ram back and forth in its cylinder. Various other terms are used to identify directional control valves, such as selector valve, transfer valve, and control valve.

Directional control valves for hydraulic and pneumatic systems are similar in design and operation. However, there is one major difference. The return port of a hydraulic valve is ported through a return line to the reservoir, while the similar port in a pneumatic valve, commonly referred to as an exhaust port, is usually vented to the atmosphere.

Directional control valves may be operated by differences in pressure acting on opposite sides of the valving element, or they may be positioned manually, mechanically, or electrically. Often two or more methods of operating the same valve will be used in different phases or its action.



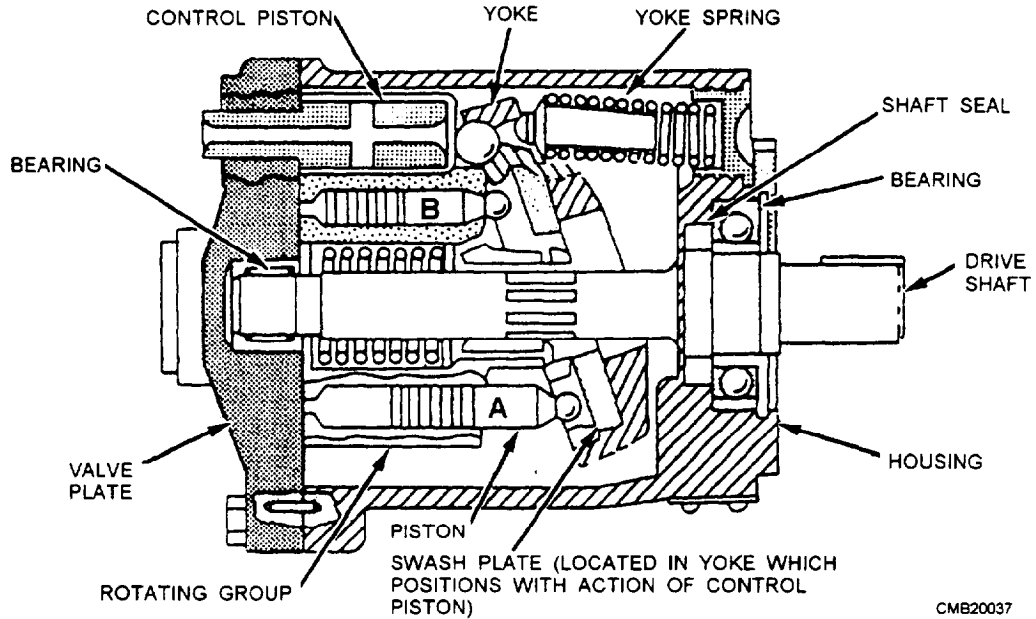
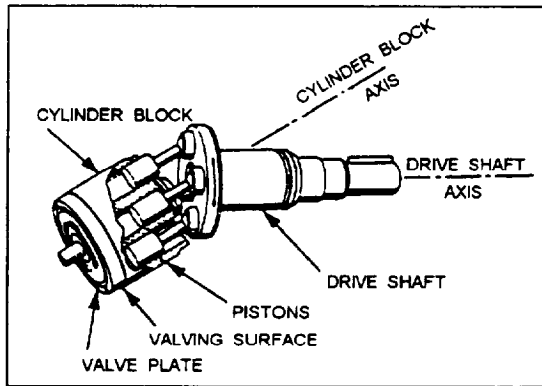

Figure 3-15.—In-line axial piston pump.

CMB20037



CMB20038

Figure 3-16.—Bent-axis axial piston pump.

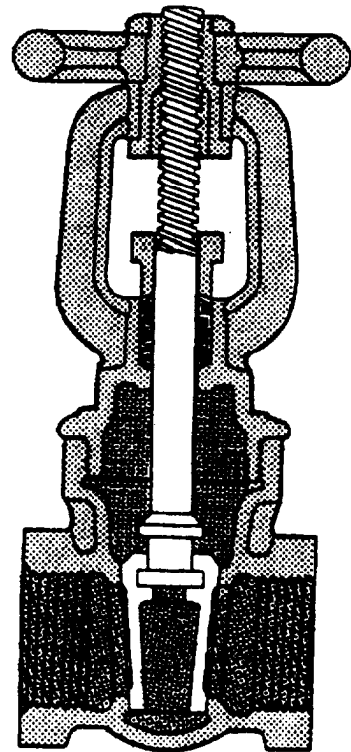

CMB20040

Figure 3-18.—Rising stem gate valve.

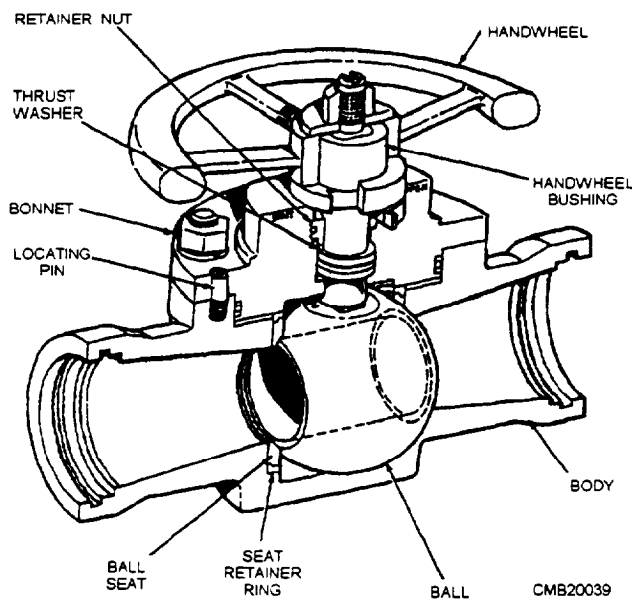

CMB20039

Figure 3-17.—Typical ball valve.

Directional control valves may be classified in several ways. Some of the different ways are by the type of control, the number of ports in the valve housing, and the specific function of the valve. The most common method is by the type of valving element used in the construction of the valve. The most common types of valving elements used in a hydraulic

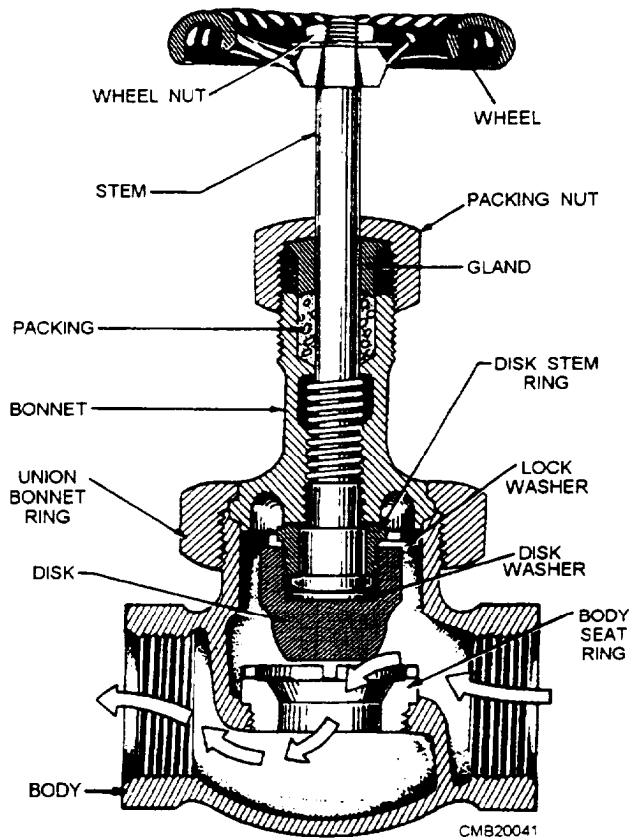
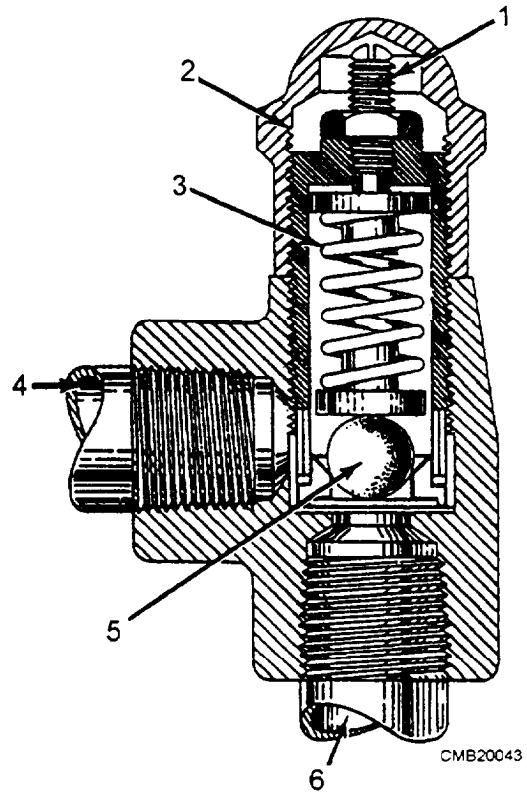

Figure 3-19.—Globe valve.



- |                       |                  |
|-----------------------|------------------|
| 1. Adjusting screw    | 4. Return port   |
| 2. Adjusting screwcap | 5. Ball          |
| 3. Spring             | 6. Pressure port |

Figure 3-21.—Typical relief valve.

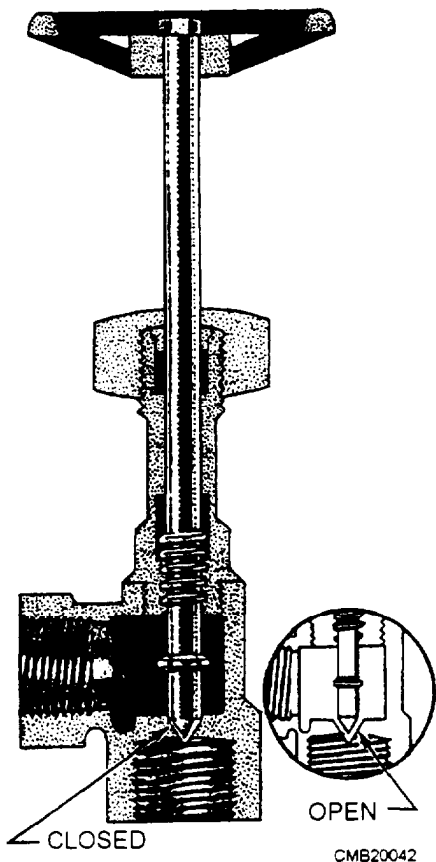

Figure 3-20.—Cross-sectional view of a needle valve.

system are the poppet (fig. 3-25), rotary spool (fig. 3-26), and sliding spool valves (fig. 3-27).

### Cylinders

An actuating cylinder is a device that converts fluid power to linear motion, or straight-line force and motion. Since linear motion is a back-and-forth motion along a straight line, this type of actuator is sometimes referred to as a reciprocating. The cylinder consists of a ram or piston operating within a cylindrical bore. Actuating cylinders may be installed so that the cylinder is anchored to a stationary structure and the ram or piston is attached to the mechanism to be operated, or the piston or ram may be anchored to the stationary structure and the cylinder attached to the mechanism to be operated.

**RAM-TYPE CYLINDERS.**—The terms *ram* and *piston* are often used interchangeably. However, a ram-type cylinder is usually considered one in which the cross-sectional area of the piston is more than one half of the cross-sectional area of the movable element. In most actuating cylinders of this type, the rod and the

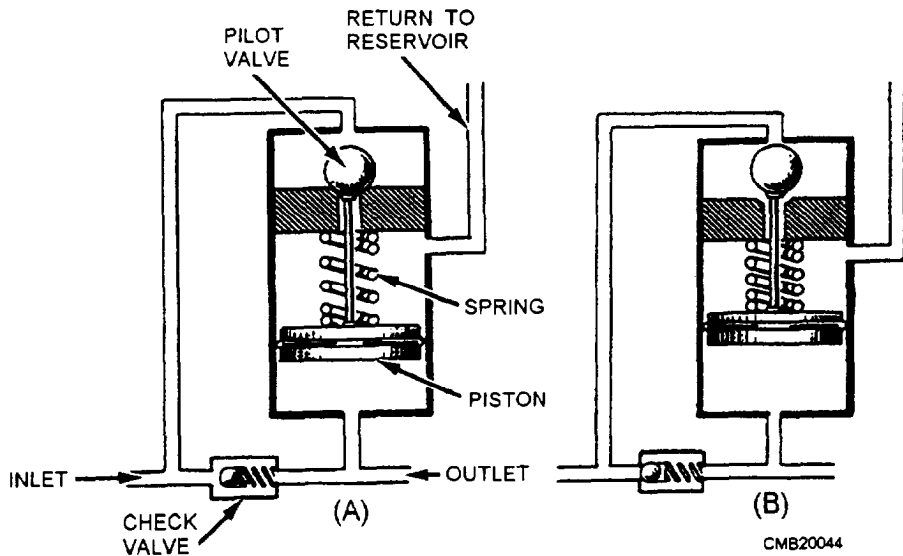

Figure 3-22.—Hydraulic pressure regulator.

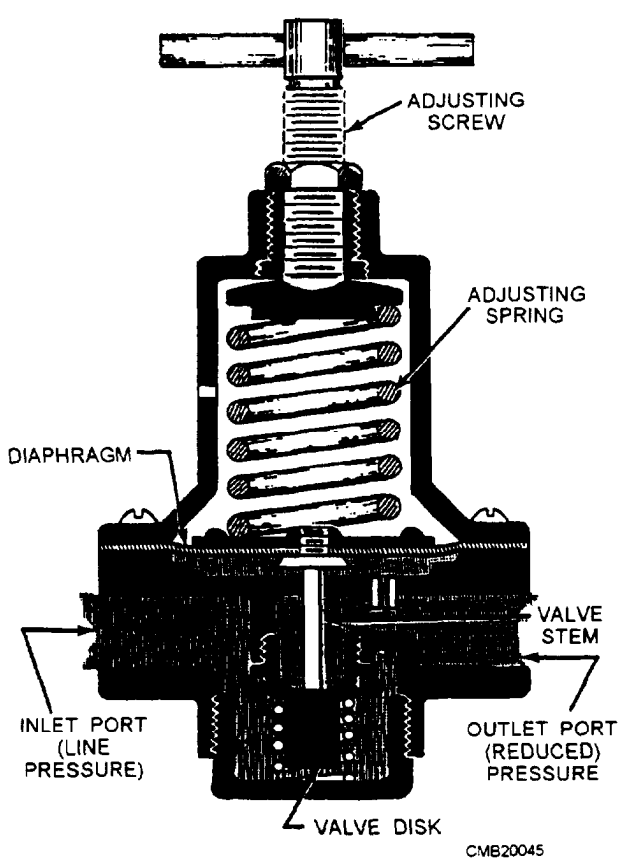
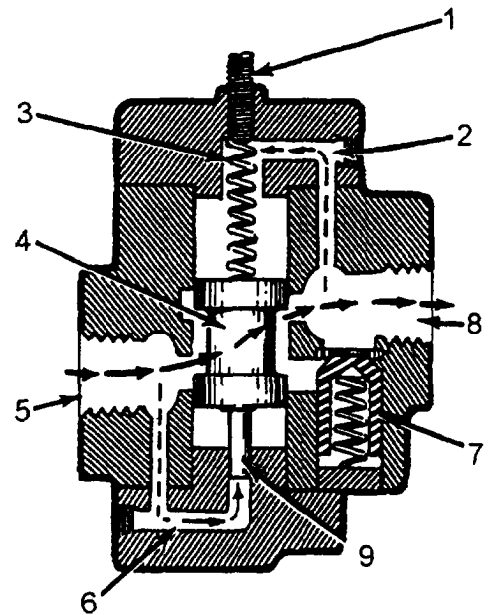

Figure 3-23.—Spring-loaded pressure-reducing valve.



- |   |  |
|---|--|
| 1. Adjustment screw                           | 6. Pilot passage                               |
| 2. Internal drain                             | 7. Check valve                                 |
| 3. Spring                                     | 8. Discharge outlet or reverse free flow inlet |
| 4. Spool                                      | 9. Piston                                      |
| 5. Pressure inlet or reverse free flow outlet |  |
- CMB20046

Figure 3-24.—Counterbalance valve.

movable element have equal areas. This type of movable element is frequently referred to as a plunger. The most common ram-type cylinders are the single- (fig. 3-28) and double-acting (fig. 3-29).

The ram-type actuator is primarily used to push, rather than pull. Some applications require simply a

flat surface on the external part of the ram for pushing or lifting the unit to be operated. Other applications require some mechanical means of attachment, such as a clevis or eyebolt. The design of ram-type cylinders varies in many other respects to satisfy the requirements of different applications.

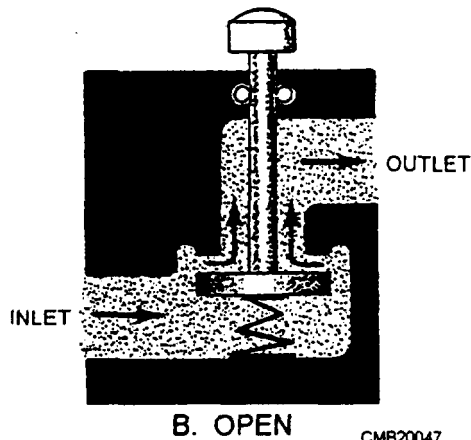
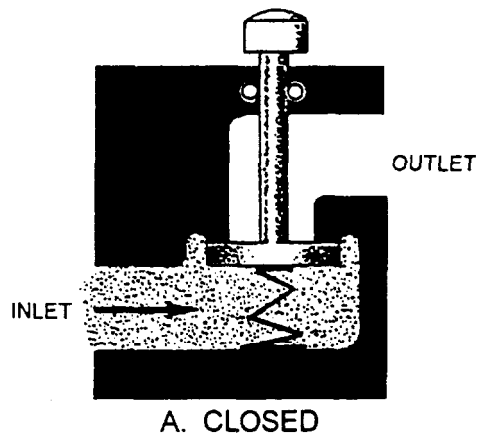

CMB20047

Figure 3-25.—The basic operation of a simple poppet valve.

**PISTON-TYPE CYLINDERS.**—An actuating cylinder in which the cross-sectional area of the piston is less than one half of the cross-sectional area of the movable element is referred to as a piston-type cylinder. This type of cylinder is normally used for applications that require both push and pull functions. The piston-type cylinder is the most common type used in fluid power systems.

The essential parts of a piston-type cylinder are a cylindrical barrel, a piston and rod, end caps, and suitable seals. The end caps are attached to the end of the barrel. These end caps usually contain fluid ports. The end cap on the rod end contains a hole for the piston rod to pass through. Suitable seals are used between the hole and the piston rod to keep fluid from leaking out and to keep dirt and other contaminants from entering the barrel. The opposite end cap of most cylinders is provided with a fitting for securing the actuating cylinder to some structure. This end cap is referred to as the anchor end cap.

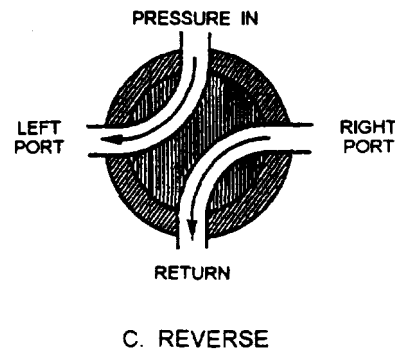
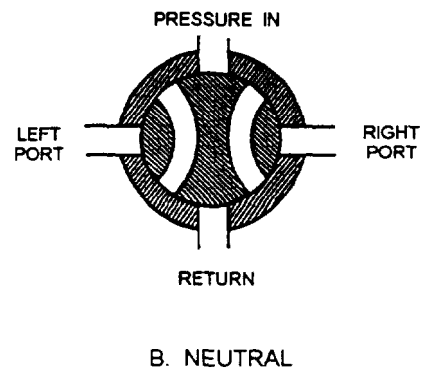
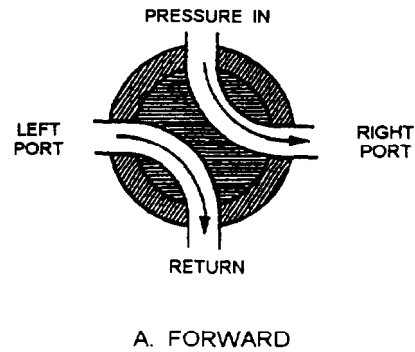

CMB20048

Figure 3-26.—Operation of a rotary spool valve.

The piston rod may extend through either or both ends of the cylinder. The extended end of the rod is normally threaded so that some type of mechanical connector, such as an eyebolt or clevis, and locknut can be attached. This threaded connection provides for adjustment between the rod and the unit to be actuated. After the correct adjustment is made, the locknut is tightened against the connector to prevent the connector from turning. The other end of the connector is attached to, either directly or through additional mechanical linkage, the unit to be actuated.

To satisfy the many requirements of fluid power systems, piston-type cylinders are available in various designs with the most common being the single- (fig. 3-30, view A) and double-acting (fig. 3-30, view B).

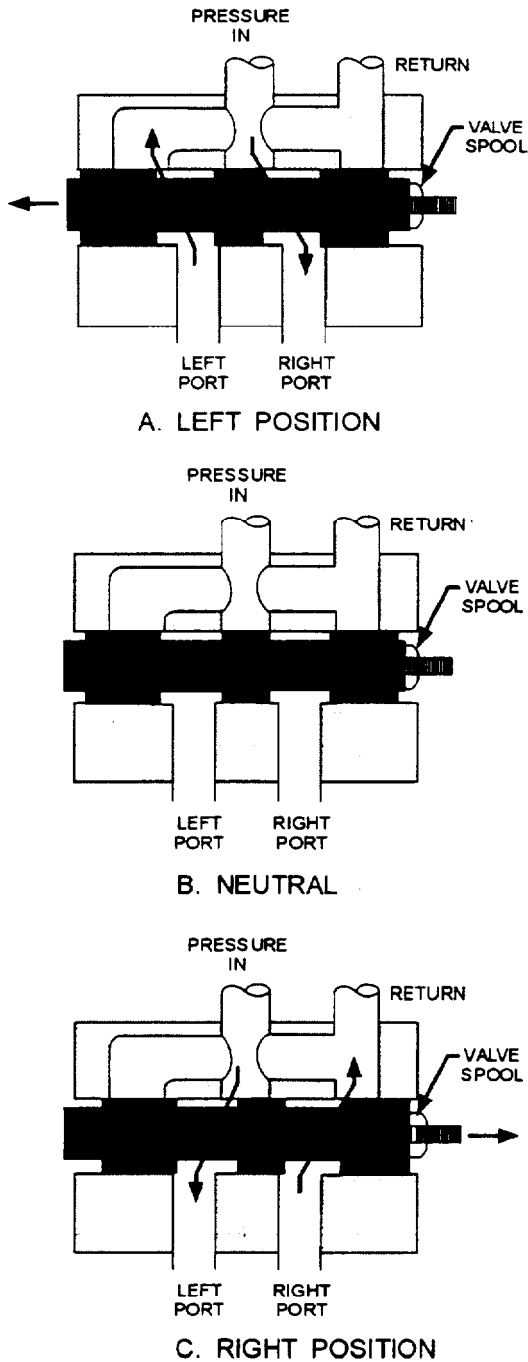

Figure 3-27.—Operation of a sliding spool valve.

### Accumulators

An accumulator is a pressure storage reservoir in which hydraulic fluid is stored under pressure from an external source. Accumulators have four major uses:

1. **Store energy.** Accumulators that store energy are often used as boosters for systems with fixed displacement pumps. The accumulator stores pressure

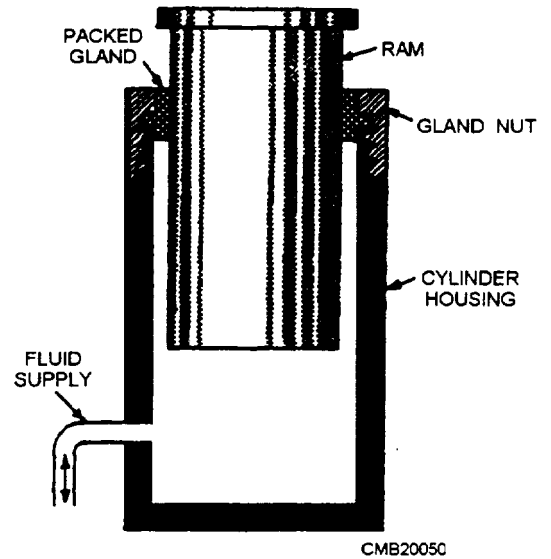

Figure 3-28.—Single-acting ram-type actuating cylinder.

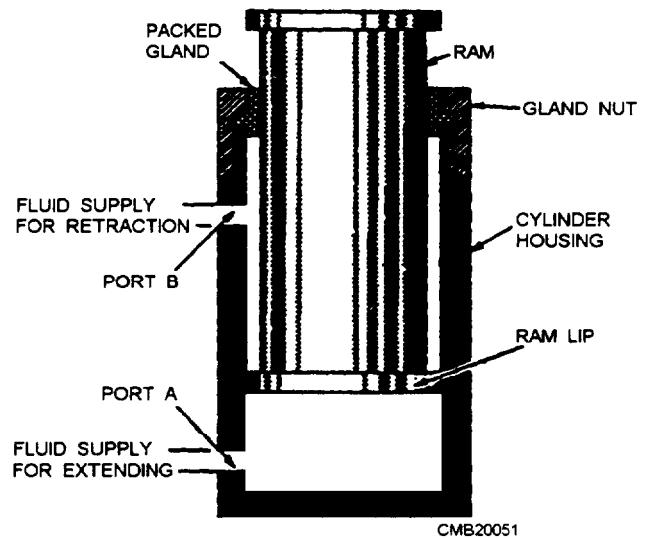

Figure 3-29.—Double-acting ram-type actuating cylinder.

oil during slack periods and feeds it back into the system during peak periods of oil usage.

2. **Absorb shocks.** Accumulators that absorb shocks take in excess oil during peak pressures and let it out again after the surge is past. This action reduces vibrations and noise in the system. It also smoothes operation during pressure delays, such as when a variable displacement pump goes into stroke.

3. **Build pressure gradually.** Accumulators that build pressure gradually are used to soften the working stroke of a piston against a fixed load as in a hydraulic press.

4. **Maintain constant pressure.** Accumulators that maintain constant pressure are always weight-loaded types that place a fixed force on the oil in a closed

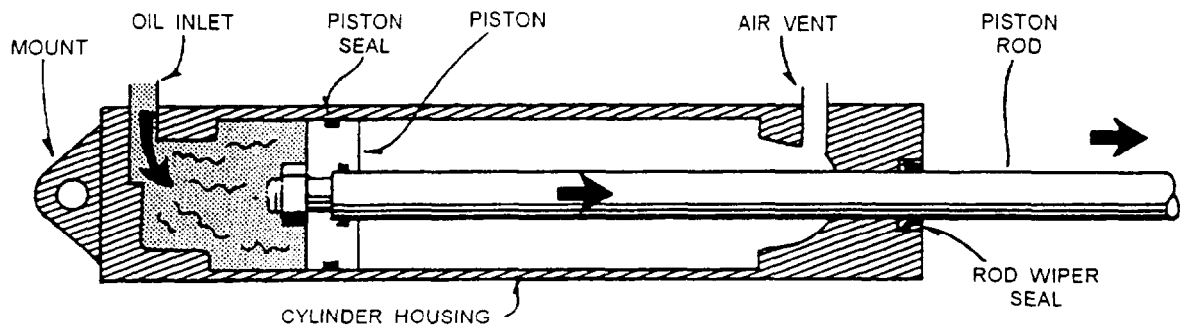

A

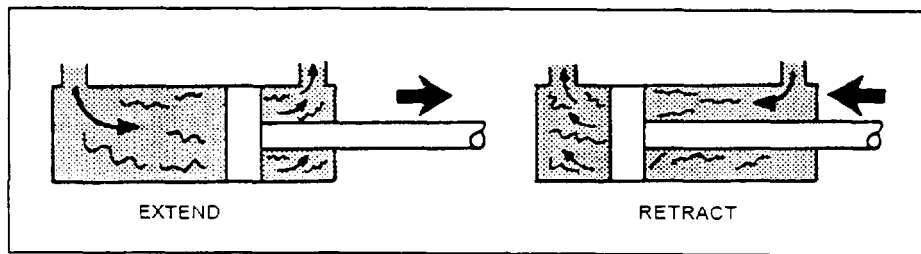
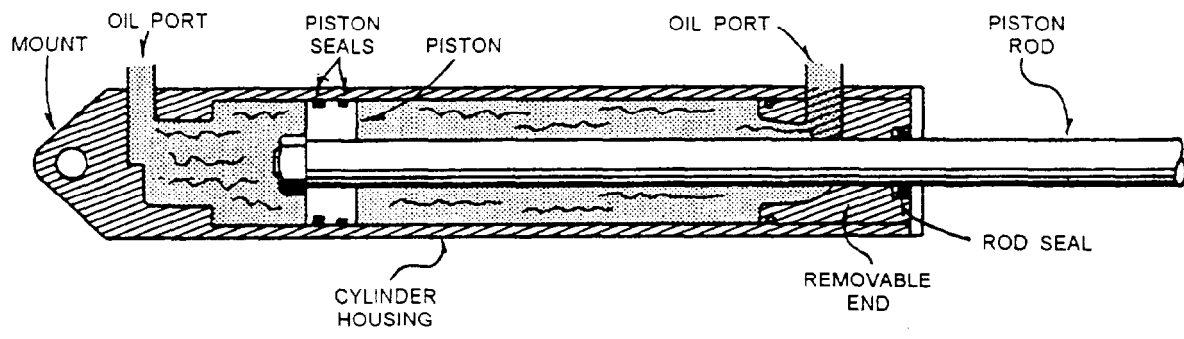

B

CMB20052

Figure 3-30.—(A) Single- and (B) double-acting piston-type cylinders.

4. **Maintain constant pressure.** Accumulators that maintain constant pressure are always weight-loaded types that place a fixed force on the oil in a closed circuit. Whether the volume of oil changes from leakage or from heat expansion or contraction, this accumulator keeps the same gravity pressure on the system.

While most accumulators can do any of these things, their use in a system is limited to only one. The major types of accumulators are as follows: pneumatic (gas-loaded), weight-loaded, spring-loaded.

**PNEUMATIC ACCUMULATORS.**—In the pneumatic accumulators, gas and oil occupy the same container. When the oil pressure rises, incoming oil

compresses the gas. When oil pressure drops, the gas expands, forcing oil out.

In most cases, the gas is separated from the oil by a piston (fig. 3-31), a bladder (fig. 3-32), or a diaphragm (fig. 3-33). This prevents mixing of gas and oil, keeping gas out of the hydraulic system.

**WEIGHT-LOADED ACCUMULATORS.**—

The weight-loaded accumulator uses a piston and cylinder along with heavy weights on the piston for loading or charging the oil. It is loaded by gravity and operation is very basic. The pressure oil in the hydraulic circuit is pushed into the lower section of the cylinder, raising the piston and weights. The accumulator is now charged and ready for work. When oil is needed, pressure drops in the system and gravity

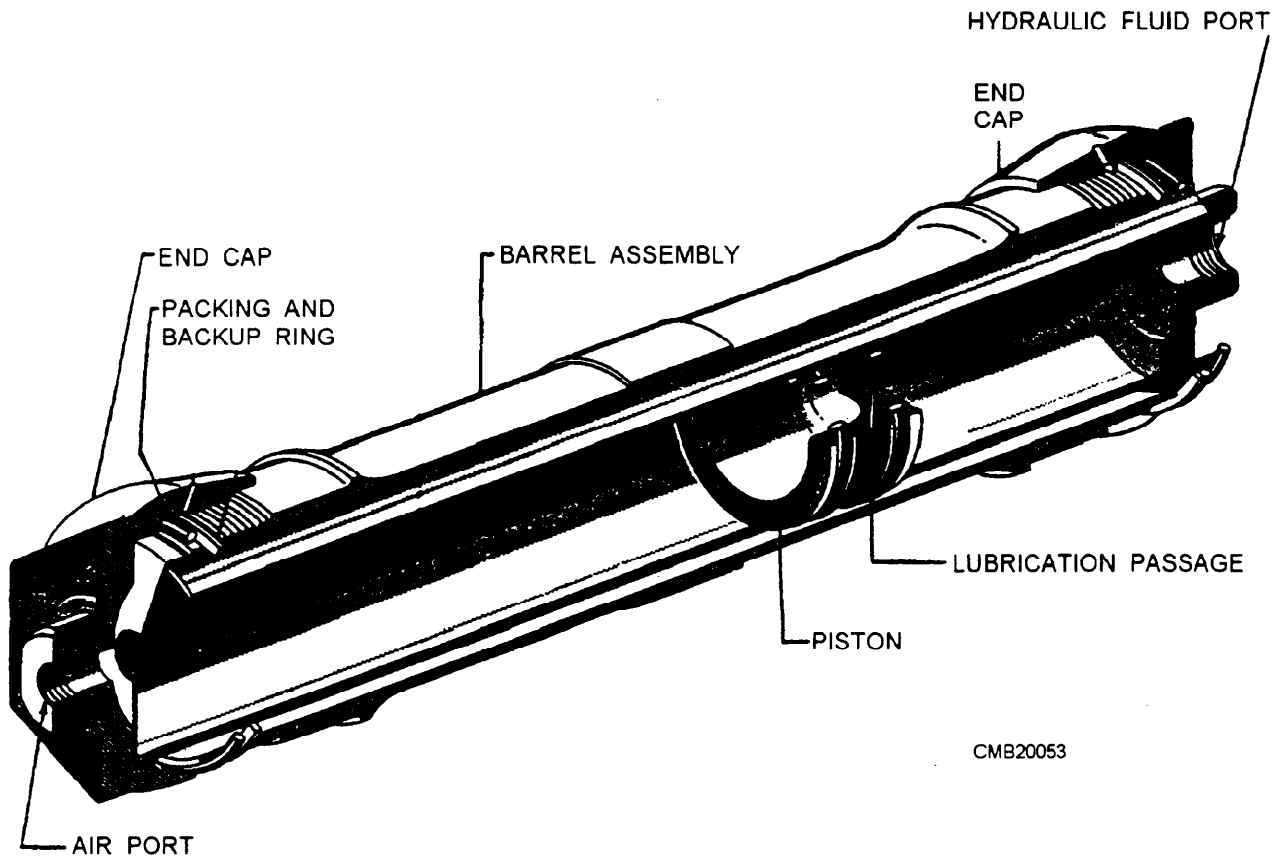

CMB20053

Figure 3-31.—Floating piston-type accumulator.

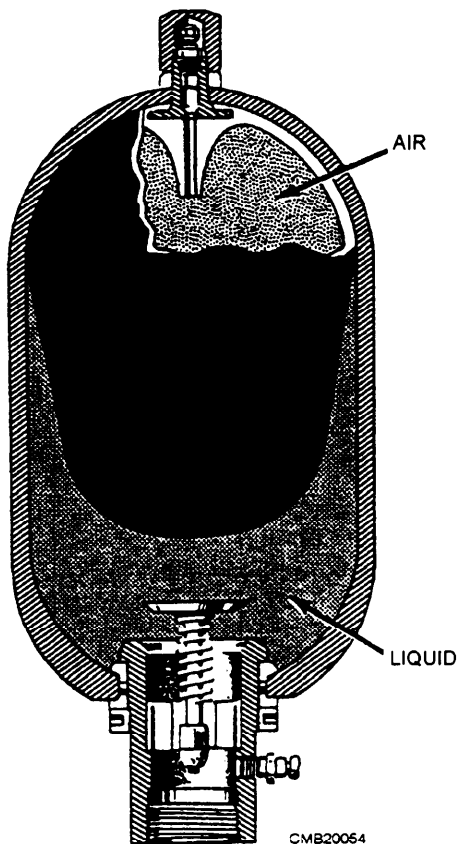

CMB20054

Figure 3-32.—Bladder-type accumulator.

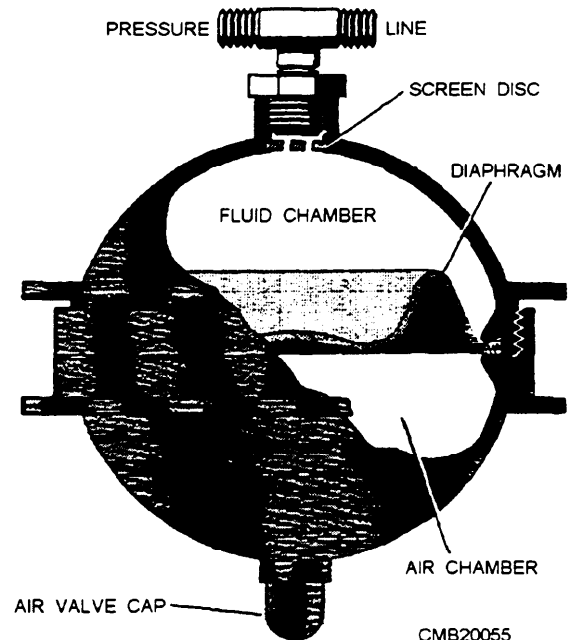

CMB20055

Figure 3-33.—Diaphragm accumulator.

disadvantage is its bulky size and heavy weight which renders it not practical for mobile equipment.

**SPRING-LOADED ACCUMULATORS.**—The spring-loaded accumulator (fig. 3-34) is very

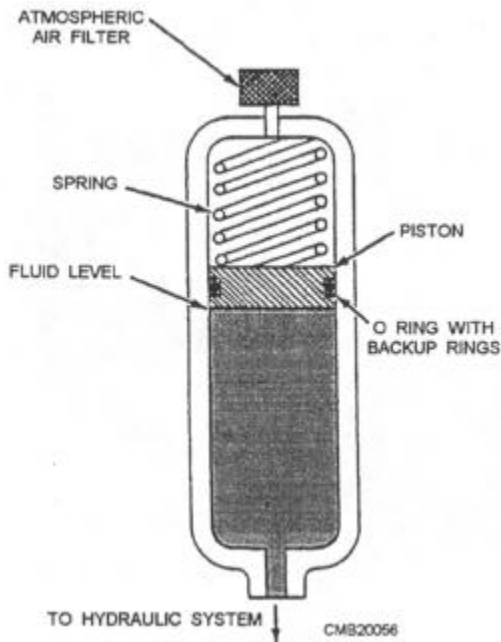

Figure 3-34.—Spring-loaded accumulator.

similar to the weight-loaded accumulator except that springs do the loading. In operation, pressure oil loads the piston by compressing the spring. When pressure drops, the spring forces oil into the system.

## Motors

A hydraulic motor is a device that converts fluid power energy to rotary motion and force. The function of a motor is opposite that of a pump. However, the design and operation of motors are very similar to pumps.

Motors have many uses in fluid power systems. In hydraulic power drives, pumps and motors are combined with suitable lines and valves to form hydraulic transmissions.

Fluid motors may either be fixed- or variable-displacement. Fixed-displacement motors provide constant torque and variable speed. Controlling the amount of input flow varies the speed. Variable-displacement motors are constructed so that the working relationship of the internal parts can be varied to change displacement. The majority of the motors used in fluid power systems are the fixed-displacement type.

Fluid motors are usually classified according to the type of internal element that is directly actuated by the flow. The most common element are the gear (fig. 3-7), the vane (fig. 3-12), and the piston (fig. 3-15).

## Tubing, Piping, and Hose

The three types of lines used in fluid power systems are tubing (semirigid), pipe (rigid), and hose (flexible). A number of factors are considered when the type of line is selected for a particular system. These factors include the type of fluid, the required system pressure, and the location of the system. For example, heavy pipe might be used for a large stationary system, but comparatively lightweight steel tubing is used in the automotive brake system. Flexible hose is required in installations where units must be free to move relative to each other.

**PIPING AND TUBING.**—The choice between pipe and tubing depends on system pressure and flow. The advantages of tubing include easier bending and flaring, fewer fittings, better appearance, better reusability, and less leakage. However, pipe is cheaper and will handle large volumes under high pressures. Pipe is also used where straight-line hookups are required and for more permanent installations.

In either case, the hydraulic lines must be compatible with the entire system. Pressure loss in the line must be kept to a minimum for an efficient system.

Pipes for hydraulic systems should be made of seamless cold-drawn mild steel. Galvanized pipe should **NOT** be used because the zinc coating could flake or scale, causing damage to the valves and pumps.

Tubing used in fluid power systems is commonly made from steel, copper, aluminum, and, in some instances, plastic. Each of these materials has its own distinct advantages or disadvantages in certain applications.

**Copper.**—The use of copper is limited to low-pressure hydraulic systems where vibration is limited. Copper has high resistance to corrosion and is easily drawn or bent. However, it is unsatisfactory for high temperatures and has a tendency to harden and break due to stress and vibration.

**Steel.**—Tubing constructed of cold-drawn steel is the accepted standard in hydraulics where high pressures are encountered. Steel is used because of its strength, stability for bending and flanging, and adaptability to high pressures and temperatures. Its chief disadvantage is its comparatively low resistance to corrosion. There are two types of steel tubing—seamless and electric welded.



**Aluminum.**—Aluminum is limited to low-pressure use, yet it has good flaring and bending characteristics.

**Plastic.**—Plastic tubing lines are made from a variety of materials; nylon is the most suitable for use in low-pressure hydraulic applications **ONLY**.

There are three important dimensions of any tubular product—**outside diameter (OD)**, **inside diameter (ID)**, and **wall thickness**. Sizes of pipe are listed by the nominal (or approximate) ID and wall thickness. Sizes of tubing are listed by the actual OD and the wall thickness.

The material, the inside diameter, and the wall thickness are the three primary considerations in the selection of lines for the circulatory system of a particular fluid power system.

The manufacturers of tubing and pipe usually supply charts, graphs, or tables which aid in the selection of proper lines for fluid power systems. These tables and charts use different methods for deriving the correct sizes of pipe and tubing.

Line should normally be kept as short and free of bends as possible. However, tubing should **NOT** be assembled in a straight line, because a bend tends to eliminate strain by absorbing vibration and compensates for thermal expansion and contraction. Bends are preferred to elbows, because bends cause less of a power loss. A few of the incorrect and correct methods of installing tubing are shown in figure 3-35.

**FLEXIBLE HOSE.**—Hose is used in fluid power systems where there is a need for flexibility, such as connection to units that move while in operation or to units attached to a hinged portion of the equipment. It is also used in locations that are subjected to severe vibration. Flexible hose is usually used to connect the pump to the system. The vibration that is set up by the

operating pump would ultimately cause rigid tubing to fail.

Flexible hose is designated by a dash number, which is the ID of the hose expressed in 16ths of an inch and is stenciled on the side of the hose. For example, the inside of a -16 hose is 1 inch. For a few hose styles, this is approximate and is not a true ID.

Rubber hose is designed for specific fluid, temperature, and pressure ranges and is provided in various specifications. Flexible hydraulic hose is composed of three basic parts (fig. 3-36):

**Inner Tube.**—The inner tube is a synthetic rubber layer that is oil-resistant. It must be smooth, flexible, and able to resist heat and corrosion.

**Reinforcement Layers.**—The reinforcement layers vary with the type of hose. These layers (or plies) are constructed of natural or synthetic fibers, braided wire, or a combination of these. The strength of this layer depends upon the pressure requirement of the system.

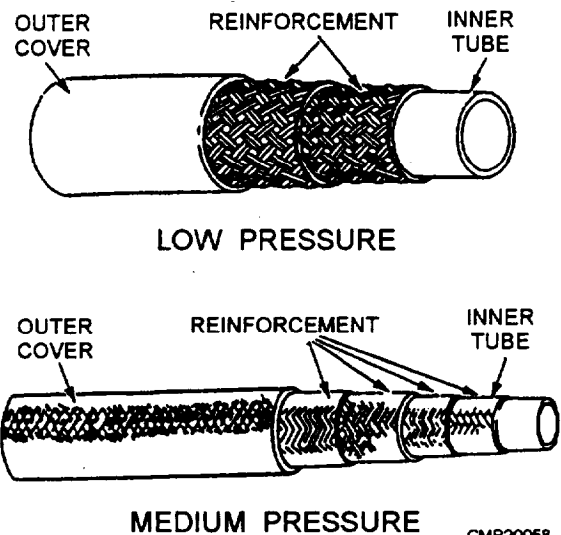

CMB20058

Figure 3-36.—Flexible rubber hose construction.

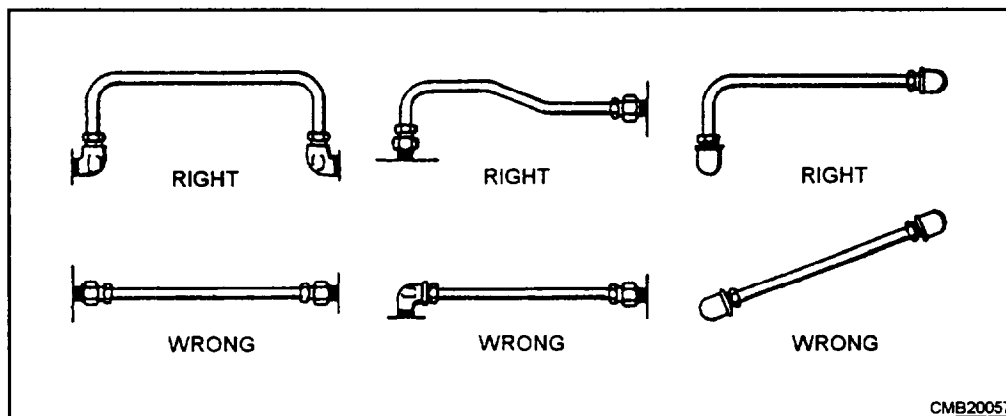

CMB20057

Figure 3-35.—Correct and incorrect methods of installing tubing.

**Outer Cover.**—The outer cover protects the reinforcement layers. A special rubber is most commonly used for the outer layer because it resists abrasion and exposure to weather, oil, and dirt.

Flexible hose is provided in four-pressure ranges. Low pressure is used in a low-pressure system and for the exhaust lines of high-pressure systems. Medium-pressure hose is used in systems with pressures up to 1,200 psi; high-pressure hose is used with pressures up to 3,000 psi; and extra-high-pressure hose is used in systems with pressures up to 5,000 psi. High- and extra-high-pressure hoses normally come as complete assemblies with factory installed end fittings. Medium- and low-pressure hose are available in bulk and are usually fabricated locally.

Flexible hose must **NOT** be twisted on installation, since this reduces the life of the hose considerably and may cause fittings to loosen as well. You can determine whether or not a hose is twisted by looking at the lay line that runs along the length of the hose. This lay line should not tend to spiral around the hose (fig. 3-37).

Hose should be installed so that it will be subjected to a minimum of flexing during operation. Support clamps are not necessary with short installations, but with hoses of considerable length (48 inches for example), clamps should be placed not more than 24 inches apart. Closer supports are desirable and, in some cases, needed.

Hose must **NEVER** be stretched tight between two fittings. About 5 to 8 percent of the total length must be allowed as slack to provide freedom of movement under pressure. When flexible hose is under pressure, it contracts in length and expands in diameter. Examples of correct and incorrect installations of flexible hose are shown in figure 3-37.

### Connectors and Fittings

There are many types of connectors and fittings required for a fluid power system. The type of connector or fitting depends upon the type of circulatory system (pipe, tubing, or flexible hose), the fluid medium, and the maximum operating pressure of the system. Some of the most common connectors and fittings are described in the following paragraphs.

**THREADED CONNECTORS.**—Threaded connectors (fig. 3-38) are used in low-pressure pipe systems. The connectors are made with standard pipe threads cut on the inside surface of the connector. The end of the pipe is threaded on the outside for connecting with the connector. Standard pipe threads are tapered slightly to ensure a tight connection.

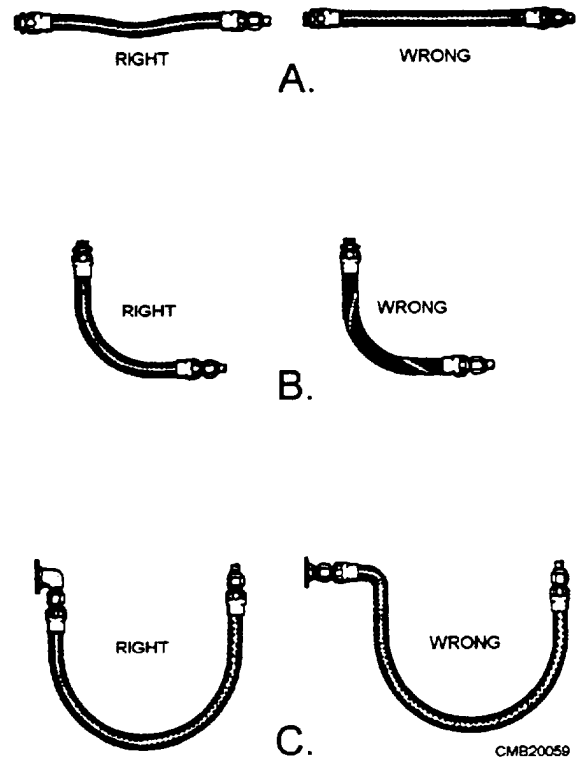

Figure 3-37.—Correct and incorrect installation of flexible hose.

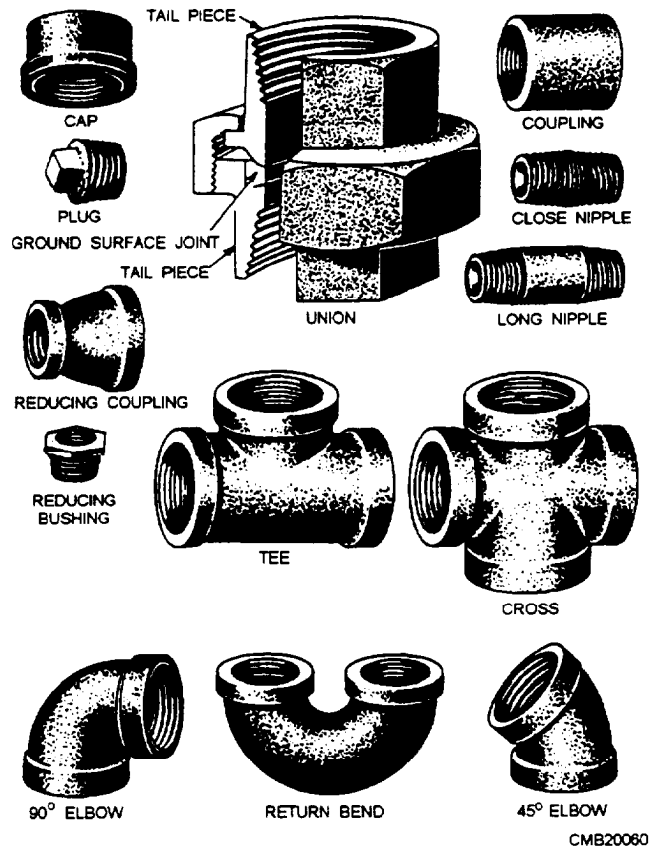

Figure 3-38.—Threaded pipe connectors.

To prevent seizing, you can apply a suitable pipe thread compound to the threads. When a compound is applied to the threads, the two end threads are to be kept free of the compound so that it will not contaminate the fluid. Pipe compound, when improperly applied, may get inside lines and harm pumps and control equipment. Because of this reason many manufacturers forbid the use of such compounds when fabricating the piping for a system.

Another material used on pipe thread is sealant tape, made by TEFLON™. This tape is made of polytetrafluoroethylene (PTFE), which provides an effective means of sealing pipe connections and eliminates the need of having to torque connections to excessively high values to prevent leakage. It also provides for ease in maintenance whenever it is necessary to disconnect pipe joints.

**FLARED-TUBE CONNECTORS.**—Flared-tube connectors are commonly used in circulatory systems consisting of lines made of tubing. These connectors provide safe, strong, dependable connections without the necessity of threading, welding, or soldering the tubing. The connector consists of a fitting, a sleeve, and a nut (fig. 3-39).

The fittings are made of steel, aluminum alloy, or bronze. The fitting used in a connection should be made of the same material as that of the sleeve, the nut, and the tubing. For example, use steel connectors with steel tubing and aluminum alloy connectors with aluminum alloy tubing. Fittings are made in union, 45-degree and 90-degree elbows, tees and various other shapes (fig. 3-40).

Tubing used with flare connectors must be flared before assembly. The nut fits over the sleeve, and when tightened, draw the sleeve and tubing flare tightly against the male fitting to form a seal.

The male fitting has a cone-shaped surface with the same angle as the inside of the flare. The sleeve supports the tube so vibration does not concentrate at the edge of the flare and distributes the shearing action over a wider area for added strength. Correct and incorrect methods of installing flared-tube connectors are shown in figure 3-41. Tubing nuts should be tightened with a torque wrench to the value specified in applicable technical manuals.

**FLARELESS-TUBE CONNECTORS.**—The flareless-tube connector eliminates all tube flaring, yet provides a safe, strong, and dependable tube connection. This connector consists of a fitting, a sleeve or ferrule, and a nut (fig. 3-42).

Flareless-tube connectors are available in many of the same shapes and threaded combinations as flared-tube connectors (fig. 3-40). The fitting has a counterbore shoulder for the end of the tubing to rest against. The angle of the counterbore causes the cutting edge of the sleeve or ferrule to cut into the outside surface of the tube when the two are assembled.

The nut presses on the bevel of the sleeve and causes it to clamp tightly to the tube. Resistance to vibration is concentrated at this point, rather than at the sleeve cut. When fully tightened, the sleeve or ferrule is bowed

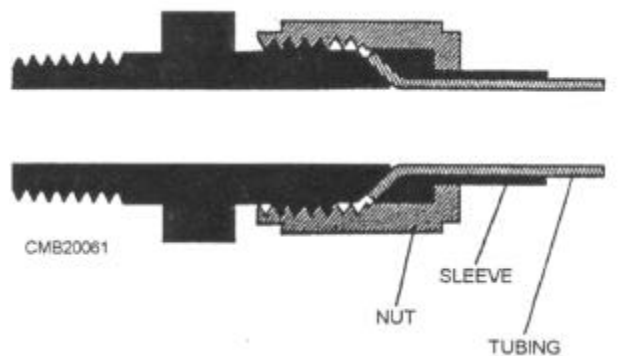
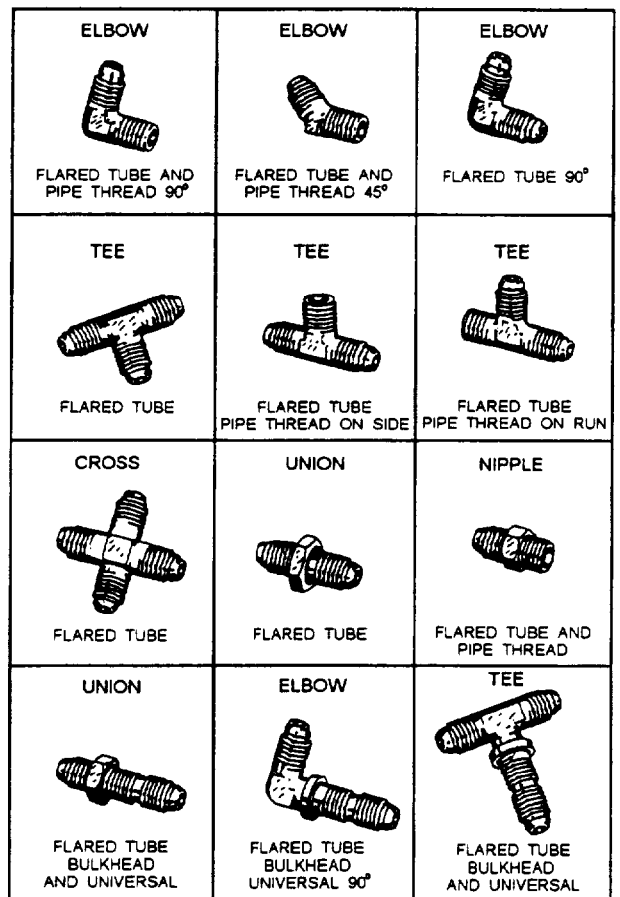

Figure 3-39.—Flared-tube connector.



CMB20062

Figure 3-40.—Flared-tube fittings.

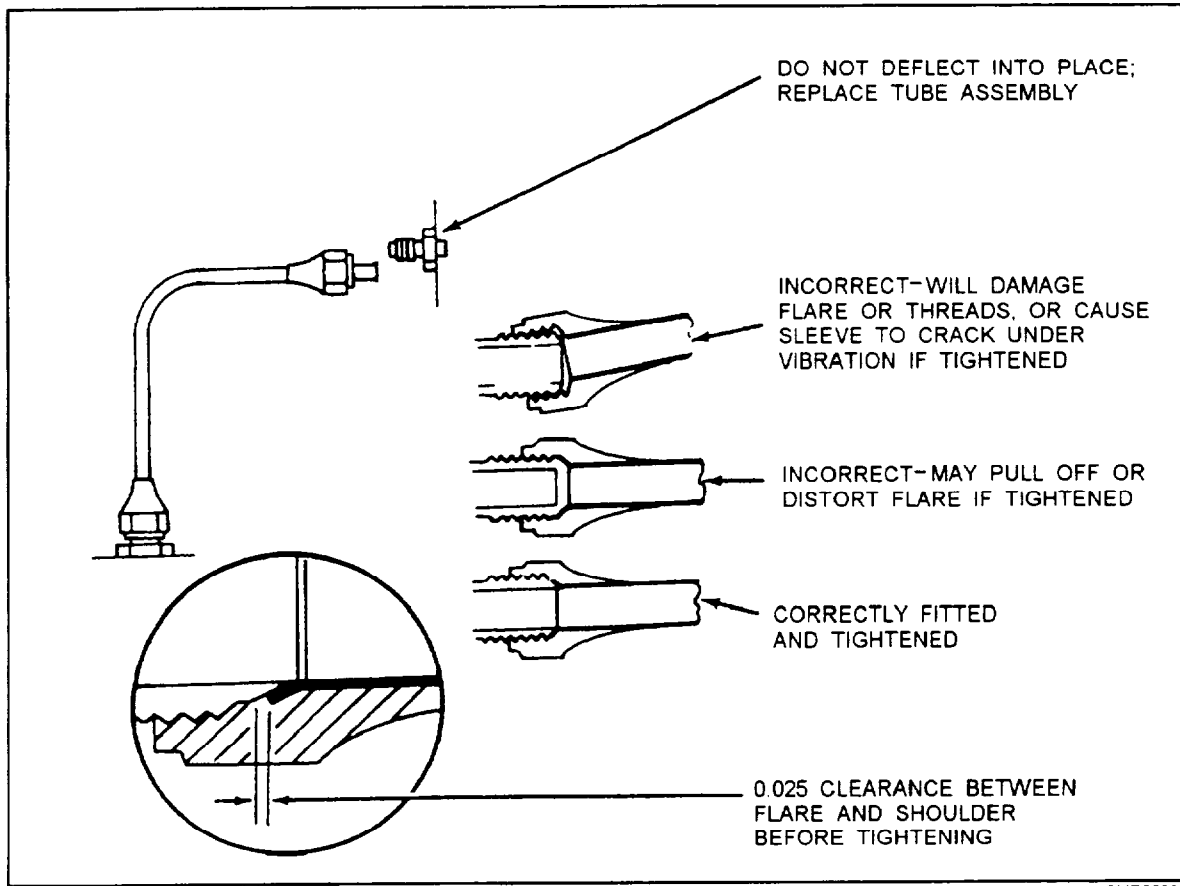

Figure 3-41.—Correct and incorrect methods of installing flared fittings.

## NOTE

When tube-type fittings are being tightened, observe the following:

Tighten only until snug. **NEVER** overtighten. More damage has been done to tube fittings by overtightening than from any other cause.

If a fitting starts to leak and appears loose, retighten only until leak stops.

Where necessary, use two wrenches on fittings to avoid twisting the lines.

**FLEXIBLE HOSE CONNECTORS.**—Flexible hose connectors are designed to be either permanent or reusable and are made of forged steel. There are various types of end fittings for both the piping connection side and the hose connection side of hose fittings (fig. 3-43).

Permanent hose fittings are discarded with the hose when the hose is damaged or defective. They are either crimped or swaged onto the hose. A crimping machine that may be found in most shops does crimping of the fitting. The crimping machine is either powered by hand, an air pump, or a hydraulic pump.

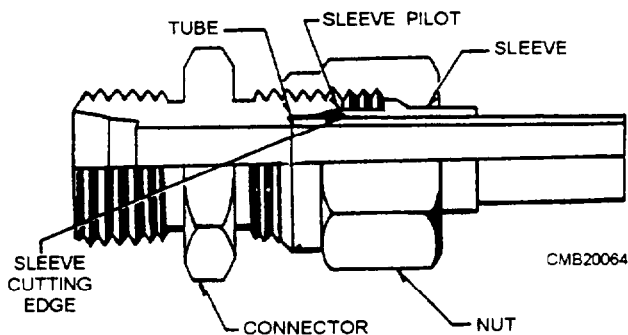

Figure 3-42.—Flareless-tube connector.

slightly at the midsection and acts as a spring. This action of the sleeve or ferrule maintains a constant tension between the body and the nut, thereby preventing the nut from loosening.

Before the installation of a new flareless-tube connector, the end of the tubing must be square, concentric, and free from burrs. For the connection to be effective, the cutting edge of the sleeve or ferrule must bite into the external surface of the tube.

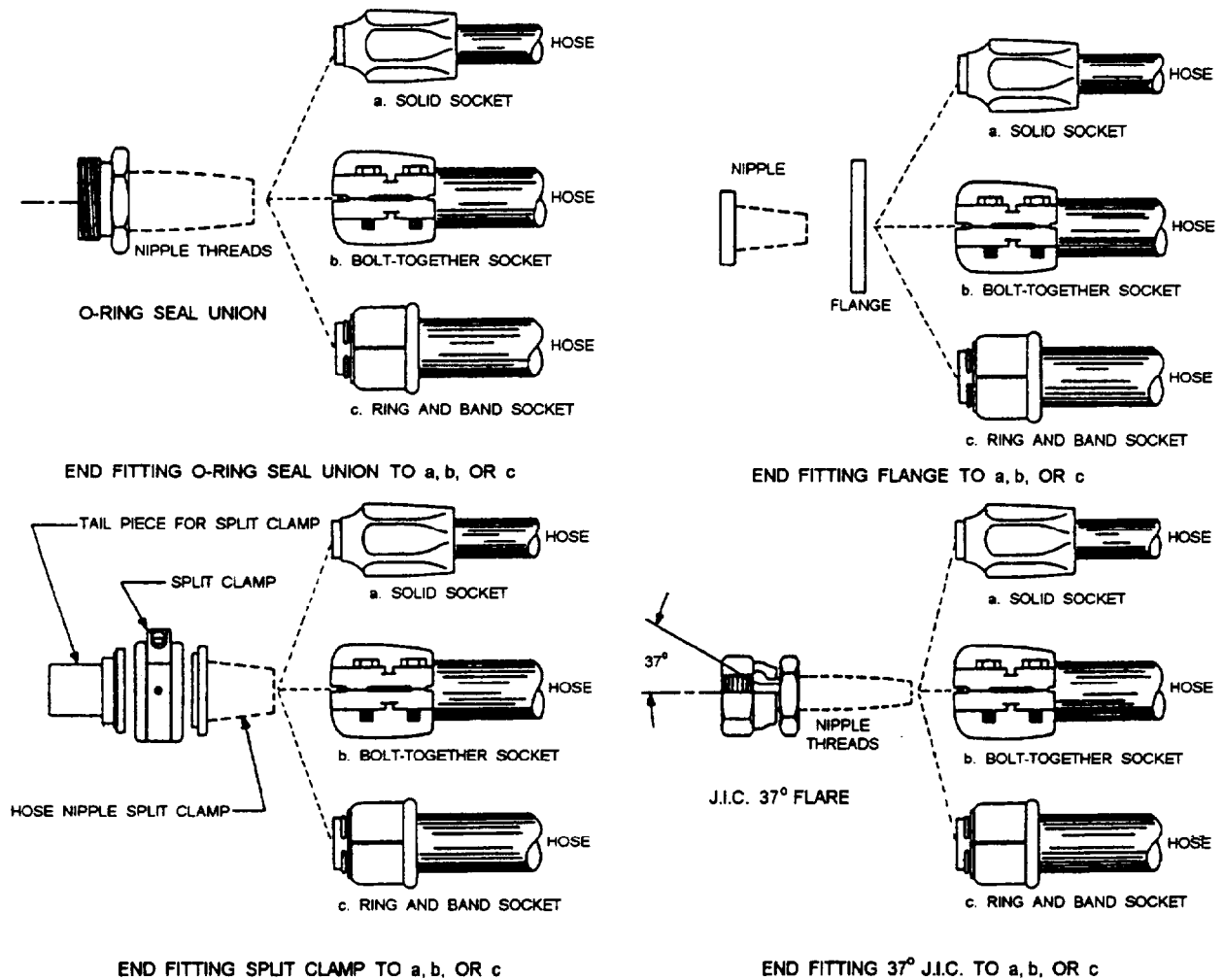

Figure 3-43.—End fittings and hose fittings.

Reusable hose fittings are pushed on, screwed on, or clamped onto the hose. When the hose wears out, the fittings can be removed and used on a new hose that is cut from stock. Many fittings can be converted to another thread type by changing the nipple in the socket.

#### NOTE

If hoses and fittings are matched incorrectly, the results can be pinhole leaks, ruptures, heat build ups, pressure drops, cavitation, and other failures.

**QUICK-DISCONNECT COUPLERS.**—Quick disconnect couplers are used where oil lines must be connected or disconnected frequently. They are self-sealing devices and do the work of two shutoff valves and a tube coupler.

These couplers are fast, easy to use, and keep oil loss at a minimum. More importantly, there is no need to drain or bleed the system every time a hookup is required.

However, dust plugs must be used when the coupler is disconnected.

#### Sealing Materials and Devices

No hydraulic circuit can operate without the proper seals to hold the fluid under pressure in the system. Seals also keep dirt and other foreign materials out of the system.

Hydraulic seals appear to be simple objects when held in the hand but, in use, they are highly complex; precision parts must be treated carefully if they are to do their job properly.

Hydraulic seals are used in the following two main applications:

1. Static seals are used to seal fixed parts. Static seals are usually gaskets, but also may be O-rings or packings.

2. Dynamic seals are used to seal moving parts. Dynamic seals include shaft and rod seals and compression packings. A slight leakage in these seals is acceptable for seal lubrication.

**SEALING MATERIALS.**—There have been many different materials used in the development of sealing devices. The material used for a particular application depends on several factors: fluid compatibility; resistance to heat, pressure, and wear resistance; hardness; and type of motion.

The selection of the correct packings and gaskets and their proper installations are important factors in maintaining an efficient fluid power system. The types of seals to be used in a particular piece of equipment are specified by the equipment manufacturer.

Seals are made of materials that have been carefully chosen or developed for specific applications. These materials include polytetrafluoroethylene (PTFE), commonly called TEFLON™, synthetic rubber, cork, leather, metal, and asbestos. The most common types of materials are discussed in the following paragraphs.

**Cork.**—The physical properties of cork make it ideally suited as a sealing material in certain applications. The compressibility of cork seals makes them well-suited for confined applications in which little or no spread of the material is allowed. The compressibility of cork also makes a good seal that can be used under various pressures and allows the gasket to be cut to any desired thickness to fit any surface, while still forming an excellent seal. Cork is generally recommended for use where sustained temperatures do not exceed 275°F.

**Synthetic Rubber.**—The materials used in synthetic rubber seals are either neoprene or nitrile-butadiene base. These seals are available in a wide range of density, tensile strength, and elongations. Many factors contribute to make synthetic rubber ideal for seals. The elasticity of the material makes it easier in many applications. Since synthetic rubber seals are virtually impermeable in their compressed state, they require less sealing load than many other types of gaskets. Synthetic rubber seals are used in a variety of applications and are capable of functioning in temperature ranges as wide as -65°F to +300°F.

**Leather.**—Leather is a closely-knit material that is generally tough, pliable, and relatively resistant to abrasion, wear, stress, and the effects of temperature changes. Because it is porous, it is able to absorb lubricating fluids. This porosity makes it necessary to impregnate leather for most uses. In general, leather must

be tanned and treated to make it useful as a sealing material. The tanning processes are those normally used in the leather industry. It is generally resistant to abrasion regardless of whether the grain side or flesh side is exposed to abrasive action. Leather remains flexible at low temperatures and can be forced with comparative ease into contact with metal flanges. When leather is properly impregnated, it is impermeable to most liquids and some gases. Leather is capable of withstanding the effects of temperatures ranging from -70°F to +220°F.

**Metal.**—One of the most common metal seals used in Navy equipment is copper. Flat copper rings are sometimes used as gaskets under adjusting screws to provide a fluid seal. Copper is easily bent and requires careful handling. In addition, copper becomes hard when used over a long period of time and when subjected to compression. It is advised that when a component is disassembled, the copper sealing rings should be replaced.

In some fluid power actuating cylinders, metallic piston rings are used as packing. These rings are similar in design to the piston rings used in engines.

**TYPES OF SEALS.**—Fluid power seals are usually typed according to their shape or design. These types include T-seals, O-rings, quad-rings, and U-cups, and so on. Some of the most commonly used seals are discussed in the following paragraphs.

**T-Seals.**—The T-seal has an elastomeric bidirectional sealing element resembling an inverted letter *T*. This sealing element is always paired with two special extrusion-resisting backup rings, one on each side of the *T*. The basic T-seal configuration is shown in figure 3-44, view A. The backup rings are single turn, bias cut, and are usually made of TEFLON™, nylon, or a combination of TEFLON and nylon. Nylon is widely used for T-seal backup rings because it provides excellent resistance to extrusion and has low friction characteristics.

The special T-ring configuration adds stability to the seal, eliminating spiraling and rolling. T-seals are used in applications where large clearances could occur as a result of expansion.

**O-Rings.**—An O-ring is doughnut-shaped. O-rings are usually molded from rubber compounds; however, they can be molded or machined from plastic materials. The O-ring is usually fitted into a rectangular groove that is machined into the item to be sealed.

An O-ring sealing system is often one of the first sealing systems considered when fluid closure is

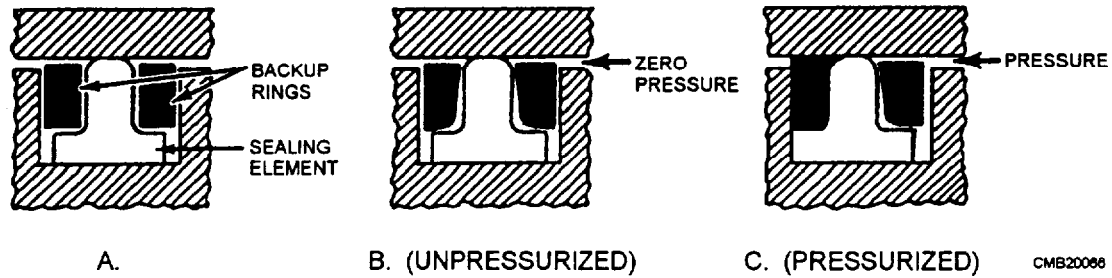

Figure 3-44.—T-seals.

designed because of the following advantages of such a system:

- Simplicity
- Ruggedness
- Low cost
- Ease of installation
- Ease in maintenance
- No adjustment required
- No critical torque in clamping
- Low distortion structure
- Small space requirement
- Effectiveness over wide pressure and temperature ranges

O-rings are used in both static (as gaskets) and dynamic (as packing) applications. An O-ring has always been the most satisfactory choice of seals in static applications when the fluids, temperatures, pressure, and geometry permit.

**Quad-Rings.**—The quad-ring is very similar to the O-ring, the major difference being that the quad-ring has a modified square type of cross section, as shown in figure 3-45. Quad-rings are molded and trimmed to extremely close tolerances in cross-sectional area, inside diameter, and outside diameter. Quad-rings are ideally suited for both low pressures and extremely high pressures.

**U-CUPS.**—The U-cup (fig. 3-46) is a popular packing due to its ease of installation and low friction. U-cups are used primarily for pressures below 1,500 psi; but, they can be used for higher pressures with the use of backup rings. When more than one U-cup is installed, they are installed back to back or heel to heel. This back-to-back installation is necessary to prevent a pressure trap (hydraulic lock) between two packings.

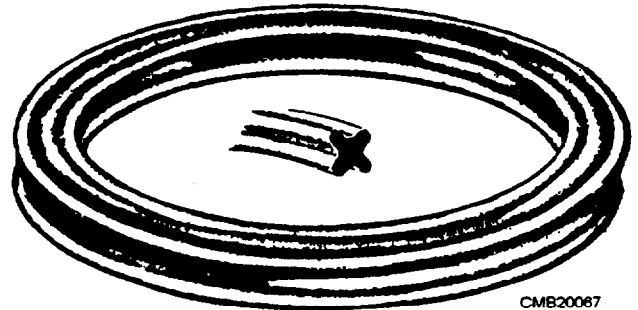

Figure 3-45.—Quad-ring.

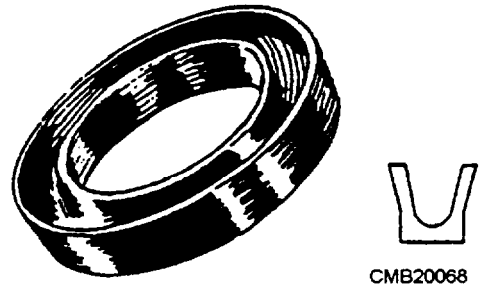

Figure 3-46.—Typical U-cup seal.

## HYDRAULIC SYSTEM MAINTENANCE

Maintenance of a hydraulic system that is properly operated and cared for is a routine task. Maintenance usually consists of changing or cleaning filters and strainers, and occasionally adding or changing the fluid in the system. However, overheating, excessive pressure, and contamination can damage an improperly operated system.

Proper maintenance reduces your hydraulic troubles. By caring for the system using a regular maintenance program, you can eliminate common problems and anticipate special ones. These problems can be corrected before a breakdown occurs.

When a hydraulic system is worked on, cleanliness is No. 1. Dirt and metal particles can score valves, seize pumps, clog orifices, resulting in major repair work.

### Oil and Filter Changes

Despite all the precautions you take when working on the hydraulic system, some contaminants will get into the system anyway. Good hydraulic oils will hold contaminants in suspension and the filters will collect them as oil passes through. A good hydraulic oil contains additives that work to keep contaminants from damaging or plugging the system. However, these additives lose their effectiveness after an extended period of time; therefore, oil changes at the recommended intervals can ensure that contamination is held to a minimum. By changing the oil at its recommended interval ensures that the additives will do their job.

Regular filter changes ensure solid particles are removed from the system. They should be changed more often under adverse operating conditions. When filters are changed, thoroughly clean the filter housing before installing a new filter. Remember to add enough fluid to compensate for any fluid lost in filter replacement.

### Cleaning and Flushing the System

Cleaning and flushing the system should be performed based on the manufacturer's recommendation or when the system is known to be contaminated. The nature and amount of deposits in a particular system may vary widely. Inspection of the system may show any condition between a sticky, oily film and a hard, solid deposit (gum or lacquer formation) which completely chokes off the system. If the system is drained periodically according to the manufacturer's recommendations, the formation of gum and lacquer will be greatly reduced.

If there is no gum or lacquer formation suspected, clean the system as follows:

1. Drain the system completely.
2. After draining, clean any sediment from the reservoir, and replace the filter elements.

If flushing is required because the oil is badly contaminated, clean and flush the system as follows:

1. Drain the system completely.
2. Refill the system with the recommended hydraulic oil for the system involved.

3. Operate the equipment to cycle the flushing oil through the system. Ensure that all valves are operated so that the new oil goes through the lines.

### NOTE

The time necessary to clean the system will vary, depending on the condition of the equipment. Usually from 4 to 48 hours is sufficient for most systems.

(Drain out the flushing oil, replace the filters, and refill the system with clean hydraulic oil of the recommended type.)

If gums or lacquer has formed on working parts and the parts are sticking, remove the affected parts and clean them thoroughly. Consult the manufacturer's manual before removing and cleaning any parts for proper procedures.

### Preventing Leaks

Leaking hydraulic connections are frequent reasons for maintenance. Some leaks are external, being evident on the outside of components. Others are internal, which does not result in actual loss of oil, but it does reduce the efficiency of the system.

**INTERNAL LEAKAGE.**—A small amount of internal leakage is allowed to provide lubrication of moving parts. This leakage is normal and does not result in faulty operation. On the other hand, an excess of internal leakage results in slow operation, loss of power, and overheating of the hydraulic fluid. The cylinders may creep or drift and, if the leak is bad enough, the control valves may not function properly.

Internal leaks are caused by wear of the seals and mating parts during normal operation. Leakage is accelerated by using oil that has too low a viscosity because the oil thins faster at higher temperatures. High pressures also force more oil out of leaking points in the system. This is why excessive pressures can actually reduce the efficiency of the hydraulic system.

Internal leaks are hard to detect. Usually, all you can do is observe the operation of the system for signs of sluggishness, creeping, and drifting. When these signs appear, it is time to test the system and pinpoint the problem.

**EXTERNAL LEAKAGE.**—External leaks not only look bad but make it hazardous for the operators of the equipment. A leak that allows floor plates to become slippery may cause the operator to fall on or off the



equipment and get injured. A leak that drips on hot engine parts may start a fire that could result in the loss of the equipment.

Every joint in a hydraulic system is a potential point of leakage. This is why the number of connections in a system must be kept to a minimum. Leaks often arise from hoses that deteriorate and rupture under pressure. Such a leak is usually first noticed when equipment has remained idle for a period of time and hydraulic fluid is found underneath. Figures 3-47 and 3-48 show the proper procedures for repairing hoses with reusable fittings. You can remove a medium- or high-pressure hose from its fittings by unscrewing the nipple from the socket and then the socket from the hose.

Here are some hints that will help reduce hose leakage and maintenance:

- Leave a little slack in the hose between connections to allow for swelling when pressure is applied. A taut hose is likely to pull out of its fittings.
- Do not loop a hose unless the manufacturer requires it. This causes unnecessary flexing of

the hose as pressure changes. Angled fittings should be used instead of loops.

- Do not twist a hose; twisting causes the hoses to weaken.
- Use clamps or brackets to keep a hose away from moving parts or to prevent chafing when the hose flexes.
- Keep hoses away from hot surfaces, such as manifold and exhaust systems. If you are unable to do so, install a heat shield to protect the hose.
- Route hoses so there are no sharp bends. This is critical with high-pressure hoses.

Sometimes you can stop leaks at fittings by tightening the hose connections. Tighten them only enough to stop the leakage. If you cannot stop a leak by tightening, secure the equipment and remove the connection. Inspect the threaded and mating parts of the connector. Look for cracks in the flared ends of the tubing. If O rings are used, examine them for cuts or tears. Any damaged or defective items should be replaced.



**SOCKETLESS**  
(Low Pressure)

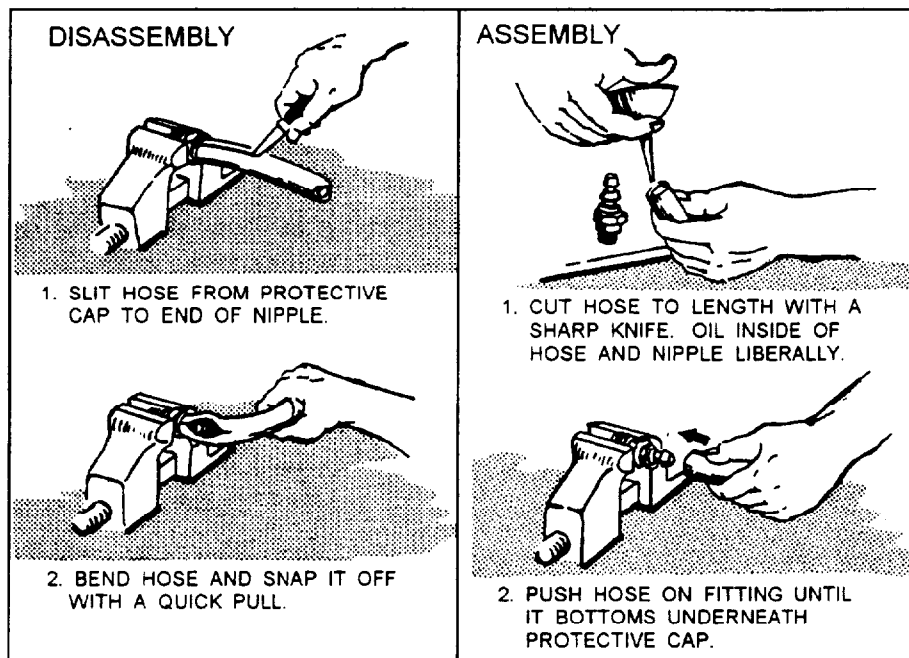

CMB20069

Figure 3-47.—Replacing low-pressure hose on a reusable fitting.

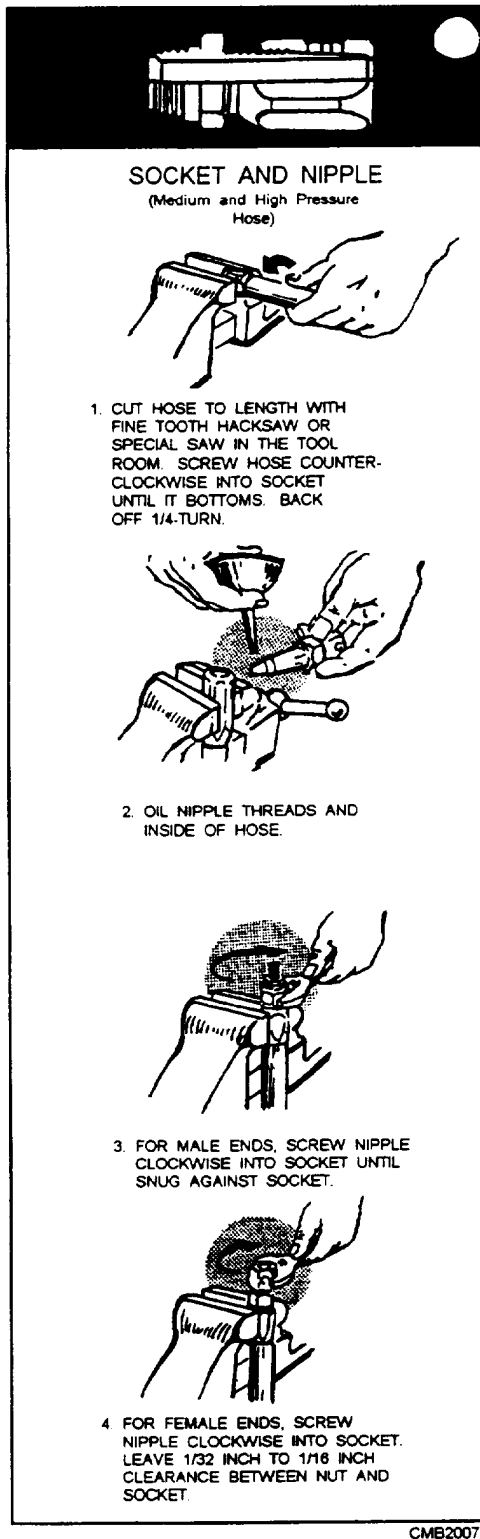

Figure 3-48.—Replacement procedures for medium- and high-pressure hose reusable fittings.

Cylinders may leak around piston rods or rams. You can repair some leaks by tightening the packing located in the cylinder end cap. Tighten the end cap evenly until only a light film of oil is noticeable on the rod when it is extended. **DO NOT** overtighten; this

results in rapid failure of the packing and causes scoring of the rod. If you find an internal seal instead of packing, the cylinder must be removed and disassembled to stop the leak. Components can leak, but care in assembly and use of new seals, packings, and gaskets during overhaul will reduce this problem.

### Preventing Overheating

Heat causes hydraulic fluid to break down faster and lose its effectiveness. In many systems, heat is dissipated through the lines, the components, and the reservoir to keep the fluid fairly cool. On high-pressure, high-speed systems, oil coolers are used to dissipate the extra heat.

The following maintenance tips will help prevent overheating.

- Ensure oil is at the proper level.
- Remove dirt and mud from lines, reservoir, and coolers.
- Repair dented and kinked lines.
- Keep relief valves adjusted properly.
- Do not overspeed or overload the system.
- Never hold control valves in the power position too long.

If the system still overheats, refer to the manufacturer's manuals for charts that list the causes and remedies for overheating.

### REVIEW 1 QUESTIONS

- Q1. If a force of 20 pounds is placed on an input piston with an area of 4 square inches, what is the pressure within the fluid?
- Q2. If an input piston that is 3 square inches is pushed down 2 inches, how far will the displaced fluid raise an output piston that is 4 square inches?
- Q3. What type of hydraulic fluid contains additives to reduce the foaming action?
- Q4. A properly constructed hydraulic reservoir should be capable of what three functions?
- Q5. That device is installed in a hydraulic system to prevent foreign particles from remaining in the system?
- Q6. What component of a hydraulic system supplies a flow of fluid to the system?

- Q7. What type of valve is used to regulate the flow of hydraulic fluid?
- Q8. What are the three dimensions of any tubular product?
- Q9. What are the three basic parts of a flexible hose?
- Q10. What type of connector is used in a low-pressure pipe system?
- Q11. When tubing nuts are tightened what tool should you use?
- Q12. What type of seal application allows for a slight leakage for seal lubrication?
- Q13. What is the most common metal seal used in Navy equipment?
- Q14. What type of seal is ideally suited for both low-pressure and high-pressure applications?
- Q15. What kind of leakage is caused by the wearing of seals and mated parts?

## PNEUMATIC SYSTEMS

**Learning Objective:** Explain the operating principles of a pneumatic system. Identify operational characteristics and service procedures applicable to heavy-duty compressors.

The word *pneumatics* is a derivative of the Greek word *pneuma*, which means air, wind, or breath. Pneumatics can be defined as that branch of engineering science that pertains to gaseous pressure and flow. As used in this manual, pneumatics is the portion of fluid power in which compressed air, or other gas, is used to transmit and control power to actuating mechanisms.

This section discusses the basic principles of pneumatics, characteristics of gases, heavy-duty air compressors, and air compressor maintenance. It also discusses the hazards of pneumatics, methods of controlling contamination, and safety precautions associated with compressed gases.

### BASIC PRINCIPLES OF PNEUMATICS

Gases differ from liquids in that they have no definite volume; that is, regardless of size or shape of the vessel, a gas will completely fill it. Gases are highly compressible, while liquids are only slightly so. Also, gases are lighter than equal volumes of liquids, making gases less dense than liquids.

## Compressibility and Expansion of Gases

Gases can be readily compressed and are assumed to be perfectly elastic. This combination of properties gives gas the ability to yield to a force and return promptly to its original condition when the force is removed. These are the properties of air that is used in pneumatic tires, tennis balls, and other deformable objects whose shapes are maintained by compressed air.

### Kinetic Theory of Gases

In an attempt to explain the compressibility of gases, consider the container shown in figure 3-49 as containing a gas. At any given time, some molecules are moving in one direction, some are travelling in other directions, and some may be in a state of rest. The average effect of the molecules bombarding each container wall corresponds to the pressure of the gas. As more gas is pumped into the container, more molecules are available to bombard the walls, thus the pressure in the container increases.

Increasing the speed with which the molecules hit the walls can also increase the gas pressure in a container. If the temperature of the gas is raised, the molecules move faster, causing an increase in pressure. This can be shown by considering the automobile tire. When you take a long drive on a hot day, the pressure in the tires increases and a tire that appeared to be soft in cool morning temperature may appear normal at a higher midday temperature.

### Boyle's Law

When the automotive tire is initially inflated, air that normally occupies a specific volume is compressed into a smaller volume inside the tire. This increases the pressure on the inside of the tire.

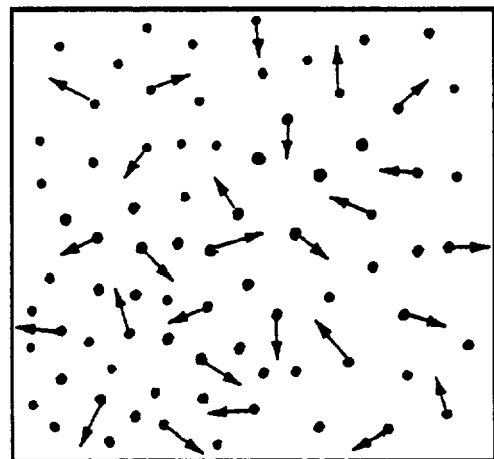

CMB20071

Figure 3-49.—Molecular bombardment creating pressure.

Charles Boyle, an English scientist, was among the first to experiment with the pressure-volume relationship of gas. During an experiment when he compressed a volume of air, he found that the volume decreased as pressure increased, and by doubling the force exerted on the air, he could decrease the volume of the air by half (fig. 3-50).

Temperature is a dominant factor affecting the physical properties of gases. It is of particular concern in calculating changes in the state of gases. Therefore, the experiment must be performed at a constant temperature. The relationship between pressure and volume is known as Boyle's law. Boyle's law states **when the temperature of a gas is constant, the volume of an enclosed gas varies inversely with pressure.**

Boyle's law assumes conditions of constant temperature. In actual situations this is rarely the case. Temperature changes continually and affects the volume of a given mass of gas.

### Charles's Law

Jacques Charles, a French physicist, provided much of the foundation for modern kinetic theory of gases. Through experiments, he found that all gases expand and contract proportionally to the change in absolute temperature, providing the pressure remains constant. The relationship between volume and temperature is known as Charles's law. Charles's law states that **the volume of a gas is proportional to its absolute temperature if constant pressure is maintained.**

### PNEUMATIC GASES

Gases serve the same purpose in pneumatic systems as liquids serve in hydraulic systems. Therefore, many of the same qualities that are considered when selecting a liquid for a hydraulic system must be considered when selecting a gas for a pneumatic system.

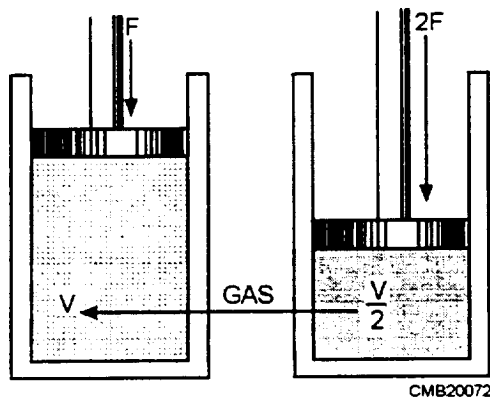

CMB20072

Figure 3-50.—Gas compressed to half its original volume by a doubled force.

### Qualities

The ideal fluid medium for a pneumatic system must be a readily available gas that is nonpoisonous, chemically stable, free from any acids that can cause corrosion of system components, and nonflammable. It should be a gas that will not support combustion of other elements.

Gases that have these desired qualities may not have the required lubricating power. Therefore, lubrication of the components must be arranged by other means. For example, some air compressors are provided with a lubricating system, some components are lubricated upon installation or, in some cases, lubrication is introduced into the air supply line (in-line oilers).

Two gases meeting these qualities and most commonly used in pneumatic systems are compressed air and nitrogen. Since nitrogen is used very little except in gas-charged accumulators, we will only discuss compressed air.

### Compressed Air

Compressed air is a mixture of all gases contained in the atmosphere. However, in this manual it is referred to as one of the gases used as a fluid medium for pneumatic systems.

The unlimited supply of air and the ease of compression make compressed air the most widely used fluid for pneumatic systems. Although moisture and solid particles must be removed from the air, it does not require the extensive distillation or separation process required in the production of other gases.

Compressed air has most of the desired characteristics of a gas for pneumatic systems. It is nonpoisonous and nonflammable but does contain oxygen which supports combustion. The most undesirable quality of compressed air as a fluid medium for a pneumatic system is moisture content. The atmosphere contains varying amounts of moisture in vapor form. Changes in the temperature of compressed air will cause condensation of moisture in the system. This condensed moisture can be very harmful to the system and may freeze the line and components during cold weather. Moisture separators and air dryers are installed in the lines to minimize or eliminate moisture in systems where moisture would deteriorate system performance.

An air compressor provides the supply of compressed air at the required volume and pressure. In

most systems the compressor is part of the system with distribution lines leading from the compressor to the devices to be operated.

Compressed air systems are categorized by their operating pressure as follows:

- High-pressure (HP)—3,000 to 5,000 psi
- Medium-pressure (MP )—151 to 1,000 psi
- Low-pressure (LP)—150 psi and below

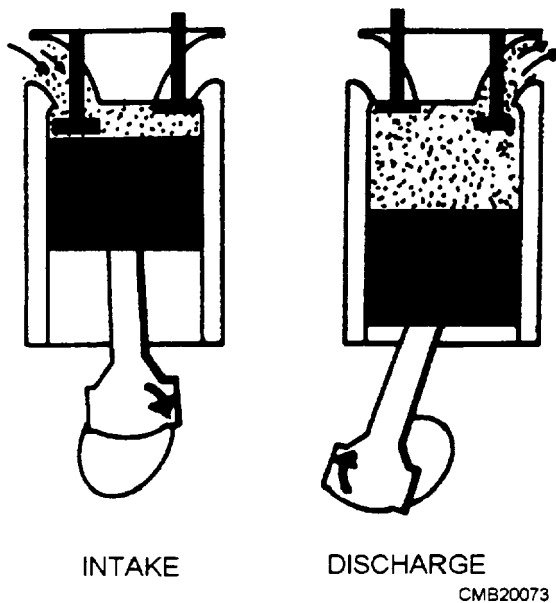

Figure 3-51.—Intake and compression strokes in a reciprocating compressor.

## HEAVY-DUTY AIR COMPRESSORS

Compressors are used in pneumatic systems to provide requirements similar to those required by pumps in hydraulic systems. They furnish compressed air as required to operate the units of the pneumatic systems.

Even though manufactured by different companies, most compressors are quite similar. They are governed by a pressure control system that can be adjusted to compress air to the maximum pressure.

### Compressor Design

The compressor unit may be of the reciprocating, rotary, or screw design.

The **reciprocating** compressor is similar to that of an automotive engine. They may be air- or liquid-cooled. As the pistons move up and down, air flows into the cylinder through the intake valve. As the piston moves upward, the intake valve closes and traps air in the cylinder. The trapped air is compressed until it exceeds the pressure within the collecting manifold, at which time the discharge valve opens and the compressed air is forced into the air manifold (fig. 3-51). The reciprocating compressor is normally connected to the engine through a direct coupling or a clutch. The engine and compressor are separate units.

The **rotary** compressor has a number of vanes held in captive in slots in the rotor. These vanes slide in and out of the slots, as the rotor rotates. Figure 3-52 shows an end

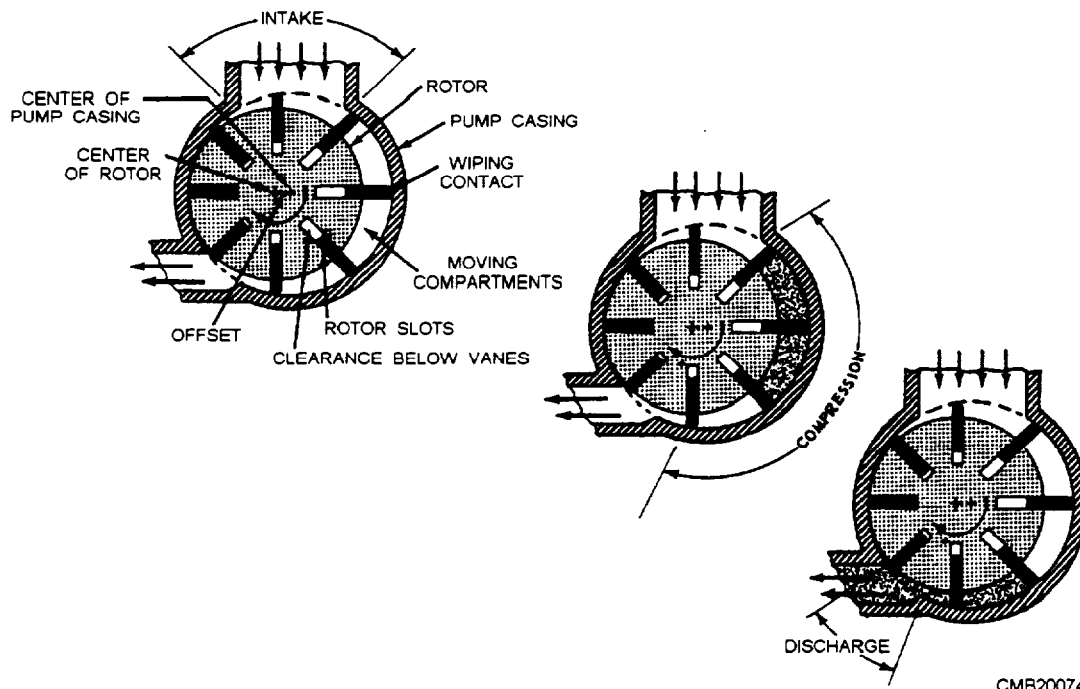

Figure 3-52.—Compression cycle in a rotary compressor.

view of the vanes in the slots. The rotor revolves about the center of the shaft that is offset from the center of the pumping casing. Centrifugal force acting on the rotating vanes maintains contact between the edge of the vanes and the pump casing. This feature causes the vanes to slide in and out of the slots, as the rotor turns.

Notice in figure 3-52 the variation in the clearance between the vanes and the bottom of the slots, as the rotor revolves. The vanes divide the crescent-shaped space between the offset rotor and the pump casing into compartments that increase in size, and then decrease in size, as the rotor rotates. Free air enters each compartment as successive vanes pass across the air intake. This air is carried around in each compartment and is discharged at a higher pressure due to the decreasing compartment size (volume) of the moving compartments as they progress from one end to the other of the crescent-shaped space.

The compressor is lubricated by oil circulating throughout the unit. All oil is removed from the air by an oil separator before the compressed air leaves the service valves.

The **screw** compressors used in the NCF are direct-drive, two-stage machines with two precisely matched spiral-grooved rotors (fig. 3-53). The rotors provide positive-displacement internal compression smoothly and without surging. Oil is injected into the compressor unit and mixes directly with the air, as the rotors turn compressing the air. The oil has three primary functions:

1. As a coolant, it controls the rise in air temperature normally associated with the heat of compression.
2. It seals the leakage paths between the rotors and the stator and also between the rotors themselves.
3. It acts as lubricating film between the rotors allowing one rotor to directly drive the other, which is an idler.

After the air/oil mixture is discharged from the compressor unit, the oil is separated from the air. The oil that mixes with the air during compression passes into the receiver-separator where it is removed and returned to the oil cooler in preparation for re-injection.

All large volume compressors have protection devices that shut them down automatically when any of the following conditions develop:

1. The engine oil pressure drops below a certain point.

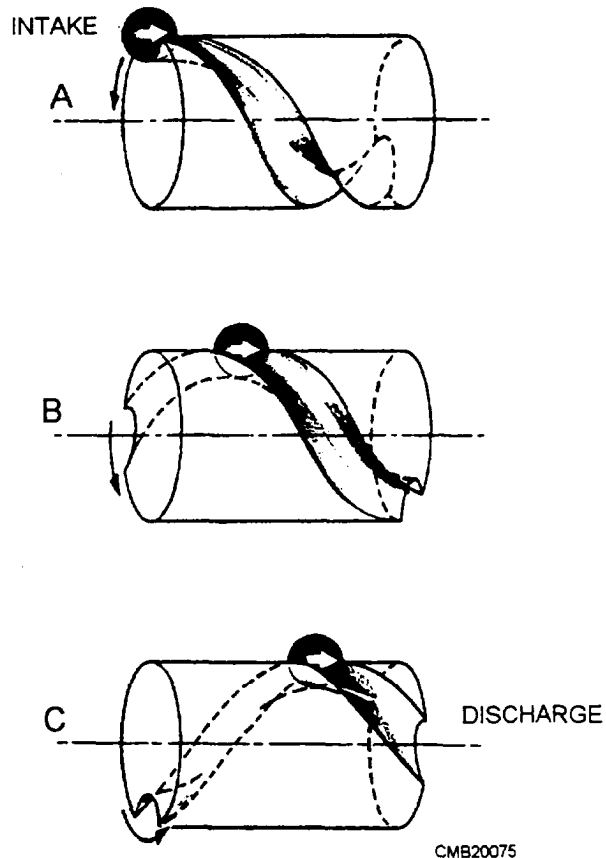
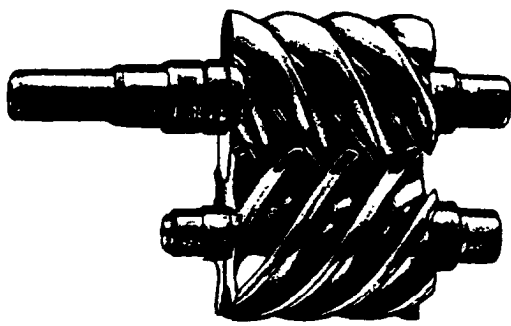

Figure 3-53.—Compression cycle in a screw compressor.

2. The engine coolant rises above a predetermined temperature.
3. The compressor discharge rises above a certain temperature.
4. Any of the protective safety circuits develop a malfunction.

Other features that may be observed in the operation of the air compressors is a governor system whereby the engine speed is reduced when less than full air delivery is used. An engine and compression control system prevents excessive buildup in the receiver.

## Intercoolers

When air is compressed, heat is generated. This heat causes the air to expand, thus requiring an increase in power for further compression. If this heat is successfully removed between stages of compression, the total power required for additional compression may be reduced by as much as 15 percent. In multistage reciprocating compressors, this heat is removed by means of intercoolers that are heat exchangers placed between each compression stage. Rotary air compressors are cooled by oil and do not use intercoolers.

## Aftercoolers

It is obvious that the presence of water or moisture in an air line is not desirable. The water is carried along through the line into the tool where the water washes away the lubricating oil, causing the tool to run sluggishly and increases maintenance. The effect is particularly pronounced in the case of high-speed tools where the wearing surfaces are limited in size and excessive wear reduces efficiency by creating internal air leakage.

Further problems may result from the decrease in temperature caused by the sudden expansion of air at the tool. This low temperature creates condensation that freezes around the valves, ports, and outlets. This condition obviously impairs the operational efficiency of the tool and cannot be allowed.

The most satisfactory means of minimizing these conditions is the removal of the moisture from the air immediately after compression and before the air enters the distribution system. This may be accomplished in reciprocating compressors through the use of an aftercooler that is an air radiator that transfers heat from the compressed air to the atmosphere. The aftercooler reduces the temperature of the compressed air to the condensation point where most of the moisture is removed. Cooling the air not only eliminates the difficulties which moisture causes at points where air is used but also ensures better distribution.

## Receiver Tank

The receiver tank is of welded steel construction and is installed on the discharge side of the compressor. It acts as a surge tank as well as a condensation chamber for the removal of oil and water vapors. It stores enough air during operation to actuate the pressure control system and is fitted with at least one service valve, a drain or blow-by valve, and a safety valve.

## Pressure-Control System

All portable air compressors are governed by a pressure-control system. The control system is designed to balance the compressor's air delivery and engine speed with varied demands for compressed air.

In a reciprocating compressor the pressure-control system causes the engine to idle and the suction valves to remain open when the pressure reaches a set maximum, thus making the compressor unit inoperative. When the air pressure drops below a set minimum, the pressure-control unit causes the engine to increase speed and the suction valves to close, thereby resuming the compression cycle.

The rotary compressor output is governed by varying the engine speed. The engine will operate at the speed required to compress enough air to supply the demand at a fairly constant pressure. When the engine has slowed to idling speed as a result of low demand, a valve controls the amount of free air that may enter the compressor.

A screw compressor output is governed by automatic control that provides smooth, stepless capacity regulation from full load to no load in response to the demand for air. From a full load down to no load is accomplished by a floating-speed engine control in combination with the variable-inlet compressor.

## AIR COMPRESSOR MAINTENANCE

A number of built-in features that make portable compressors easy to maintain include:

- an automatic blowdown valve for releasing air pressure when the engine is stopped,
- a valve for draining moisture that accumulates in the receiver tank,
- a drain cock at the bottom of the piping at the bottom of the oil storage tank,
- an air filter service indicator to show when the filter needs servicing, and
- a demister, or special filter, that separates lubricating oil from compressed air.

Remember a good maintenance program is the key to a long machine life. So it is up to both the operator and the mechanic to ensure that the maintenance is performed on time every time.

## Air Cleaner Servicing

The air cleaner contains a primary and secondary dry filter element (fig. 3-54). An air filter restriction indicator is located at the rear of the air filter housing to alert the operator of the need to service the filters. When a red band appears in the air filter restriction indicator, secure the compressor and service the filters.

The primary element is cleanable by using compressed air. When the element is cleaned, never let the air pressure exceed 30 psi. The secondary filter is not cleanable and should be replaced when necessary. Reverse flush the primary element by directing compressed air up from the inside out. Continue reverse flushing until all dust is removed. Should any oil or greasy dirt remain on the filter surface, the element should be replaced. When the element is satisfactorily cleaned, inspect it thoroughly before installation. Inspection procedures are as follows:

- Place a bright light inside the element to inspect it for damage. Concentrated light will shine through the element and disclose any holes. A damaged element is to be replaced.

- Inspect all gaskets and gasket contact surfaces of the housing. Should faulty gaskets be evident, replace them immediately.
- After the element has been installed, inspect and tighten all air inlet connections before resuming operation.

### CAUTION

Do not strike the element against any hard surface to dislodge dust. This will damage the sealing surfaces and possibly rupture the element.

## Main Oil Filter Servicing

The main oil filter is a replaceable cartridge. The servicing of the filter is required as indicated by the maintenance indicator on the filter or each time the compressor oil is changed. Under normal operating conditions, the oil is changed at approximately 500 operating hours. Under severe conditions, more frequent servicing is required.

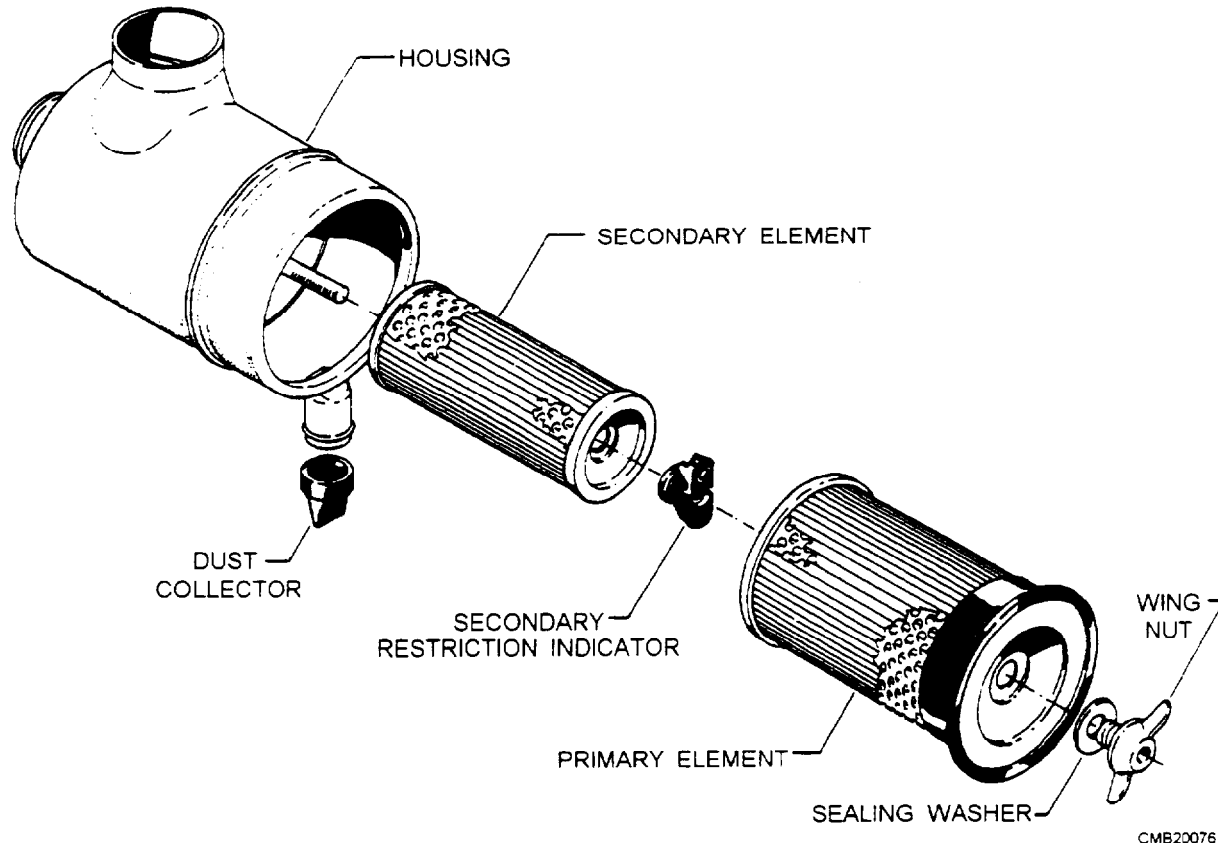

Figure 3-54.—Air filter.



## Demister or Separator Element

The demister, or separator element, is located inside the receiver tank (fig. 3-55). Replacement of the demister is indicated by the maintenance indicator (usually mounted on the receiver tank but also can be remote-mounted) or any sign of oil in the air at the service valves. You can reach the demister after removing the plate on the end of the receiver tank.

## CONTAMINATION CONTROL

As in hydraulic systems, fluid contamination is the leading cause of malfunctions in pneumatic systems. In addition to the solid particles of foreign matter that find their way to enter the system, there is also the problem of moisture. Most systems are equipped with one or more devices to remove contamination. These include filters, water separators, air dehydrators, and chemical dryers. Most systems contain drain valves at critical low points in the system. These valves are opened periodically to allow the escaping gas to purge a large percentage of the contaminants, both solids and moisture, from the system. In some systems these valves are automatic, while in others they must be operated manually.

Removing lines from various components throughout the system and then attempting to pressurize the system, causing a high rate of air flow through the system, does complete purging. The air flow will cause the foreign matter to be dislodged and blown from the system.

### NOTE

If an excessive amount of foreign matter, particularly oil, is blown from any one system, the lines and components should be removed and cleaned or, in some cases, replaced.

In addition to monitoring the devices installed to remove contamination, it is your responsibility as a mechanic to control the contamination. You can do this by using the following maintenance practices:

- Keep all tools and the work area in a clean, dirt-free condition.
- Cap or plug all lines and fittings immediately after disconnecting them.
- Replace all packing and gaskets during assembly procedures.
- Connect all parts with care to avoid stripping metal slivers from threaded areas. Install and torque all fittings and lines according to applicable technical manuals.

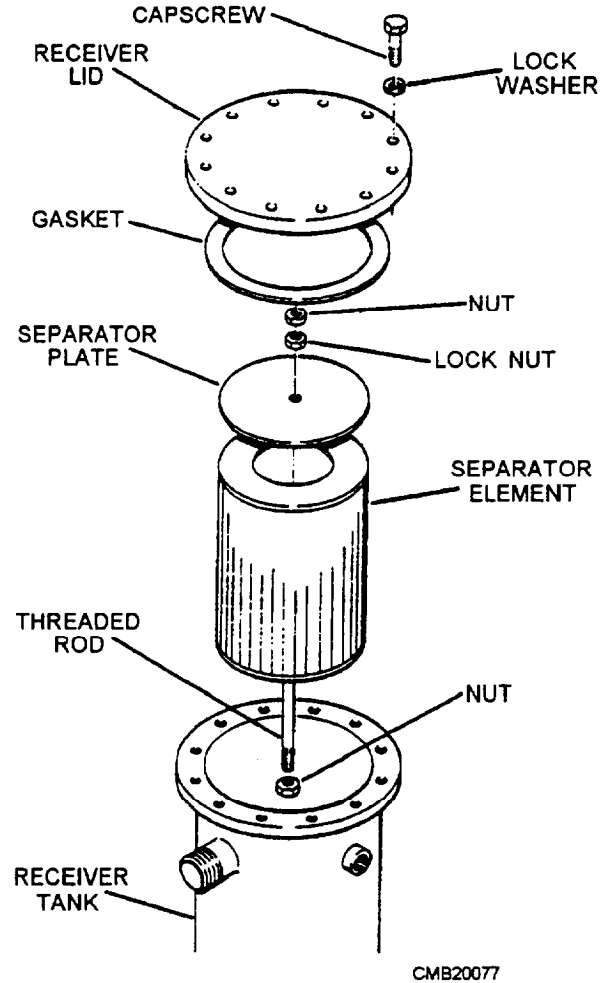

Figure 3-55.—Demister (separator element).

## POTENTIAL HAZARDS

All compressed gases are hazardous. Compressed air and nitrogen are neither poisonous nor flammable, but should be handled with care. Some pneumatic systems operate at pressures exceeding 3,000 psi. Lines and fittings have exploded, injuring personnel and property. Literally thousands of careless workers have blown dust or other harmful particles into their eyes by careless handling of compressed air outlets.

If you ever have to handle nitrogen gas, remember that it will not support life, and when released in a confined space, it will cause asphyxia (the loss of consciousness as a result of too little oxygen and too much carbon dioxide in the blood). Although compressed air and nitrogen seem safe in comparison with other gases, do not let overconfidence lead to personal injury.

## SAFETY PRECAUTIONS

To minimize personal injury and equipment damage when using compressed gases, observe all

## **SAFETY PRECAUTIONS**

To minimize personal injury and equipment damage when using compressed gases, observe all practical operating safety precautions, including the following:

- Do **NOT** use compressed air to clean parts of your body or clothing or to perform general space cleanup instead of sweeping.
- **NEVER** attempt to stop or repair a leak while the leaking portion is still under pressure. Always isolate, depressurize, and tag out the portion of the system to be repaired.
- Avoid the application of heat to the air piping system or components, and avoid striking a sharp, heavy blow on any pressurized part of the piping system.
- Avoid rapid operation of manual valves. The heat of compression caused by a sudden high-pressure flow into an empty line or vessel can cause an explosion if oil is present. Valves should be slowly cracked open until air flow is noted and should be kept in this position until pressures on both sides of the valve have equalized. The rate of pressure rise should be kept under 200 psi per second, if possible. Valves may then be opened fully.

- Do **NOT** subject compressed gas cylinders to temperatures greater than 130°F. Remember, any pressurized system can be hazardous to your health if it is not maintained and operated carefully and safely.

## ***REVIEW 2 QUESTIONS***

- Q1. What two properties allow gas the ability to yield to force and return to its original condition when the force is removed?*
- Q2. What law states that when the temperature of a gas is constant, the volume of enclosed gas varies inversely with pressure?*
- Q3. What four qualities should the ideal gas have for pneumatic system?*
- Q4. What is the most undesirable quality of compressed air when used as a fluid medium for a pneumatic system?*
- Q5. A pneumatic system with an operating pressure of 500 psi is known as what type of system?*
- Q6. What are the three designs of air compressors?*
- Q7. What device in a rotary air compressor removes oil from the compressed air before the air leaves the service valves?*

## REVIEW 1 ANSWERS

- Q1. 5 psi*
- Q2. 1 inch*
- Q3. Petroleum-based fluids*
- Q4. Dissipating heat, separating air, settling out contamination*
- Q5. Filters*
- Q6. Pump*
- Q7. Flow-control valve*
- Q8. Inside diameter, outside diameter, wall thickness*
- Q9. Inner tube, reinforcement layers, outer cover*
- Q10. Threaded connectors*
- Q11. Torque wrench*
- Q12. Dynamic seal*
- Q13. Copper*
- Q14. Quad-ring*
- Q15. Internal leakage*

## REVIEW 2 ANSWERS

- Q1. Compressibility and elasticity*
- Q2. Boyle's law*
- Q3. Nonpoisonous, chemical stable, free from corrosive acids, and nonflammable*
- Q4. Moisture content*
- Q5. Medium-pressure system*
- Q6. Reciprocating, rotary, and screw*
- Q7. Oil separator*



## CHAPTER 4

# AUTOMOTIVE CLUTCHES, TRANSMISSIONS, AND TRANSAXLES

### INTRODUCTION

**Learning Objective:** State the operating principles and identify the components and the maintenance for a clutch, a manual transmission, an automatic transmission, and a transaxle.

In a vehicle, the mechanism that transmits the power developed by the engine to the wheels and/or tracks and accessory equipment is called the **power train**. In a simple application, such as a stationary engine-powered hoist, a set of gears or a chain and sprocket could perform this task. However, automotive and construction equipment are not designed for such simple operating conditions. They are designed to provide pulling power, to move at high speeds, to travel in reverse as well as forward, and to operate on rough terrain as well as smooth roads. To meet these varying conditions, vehicle power trains are equipped with a variety of components. This chapter discusses the basic automotive clutch, transmissions (manual and automatic), and transaxles (manual and automatic).

### AUTOMOTIVE CLUTCHES

**Learning Objective:** State the operating principles and identify the components and maintenance requirements for an automotive clutch.

An automotive clutch is used to connect and disconnect the engine and manual (hand-shifted) transmission or transaxle. The clutch is located between the back of the engine and the front of the transmission.

With a few exceptions, the clutches common to the Naval Construction Force (NCF) equipment are the single-, double-, and multiple-disc types. The clutch that you will encounter the most is the single-disc type, as shown in figure 4-1. The double-disc clutch (fig. 4-2) is substantially the same as the single disc, except that another driven disc and an intermediate driving plate are added. This clutch is used in heavy-duty vehicles and construction equipment. The multiple-disc clutch is used in the automatic transmission and for the steering clutch used in tracked equipment.

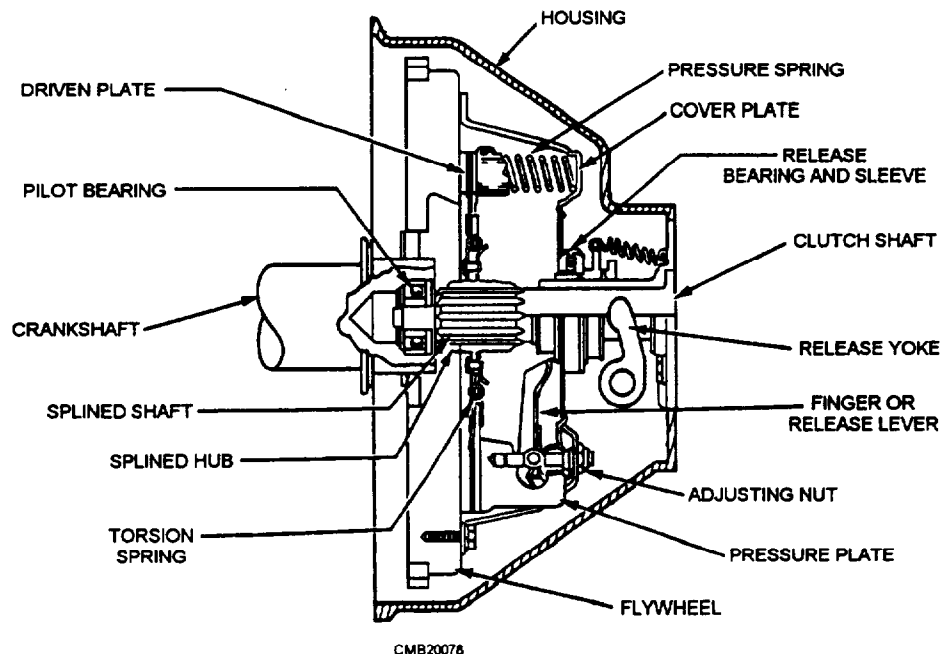

Figure 4-1.—Single-disc clutch.

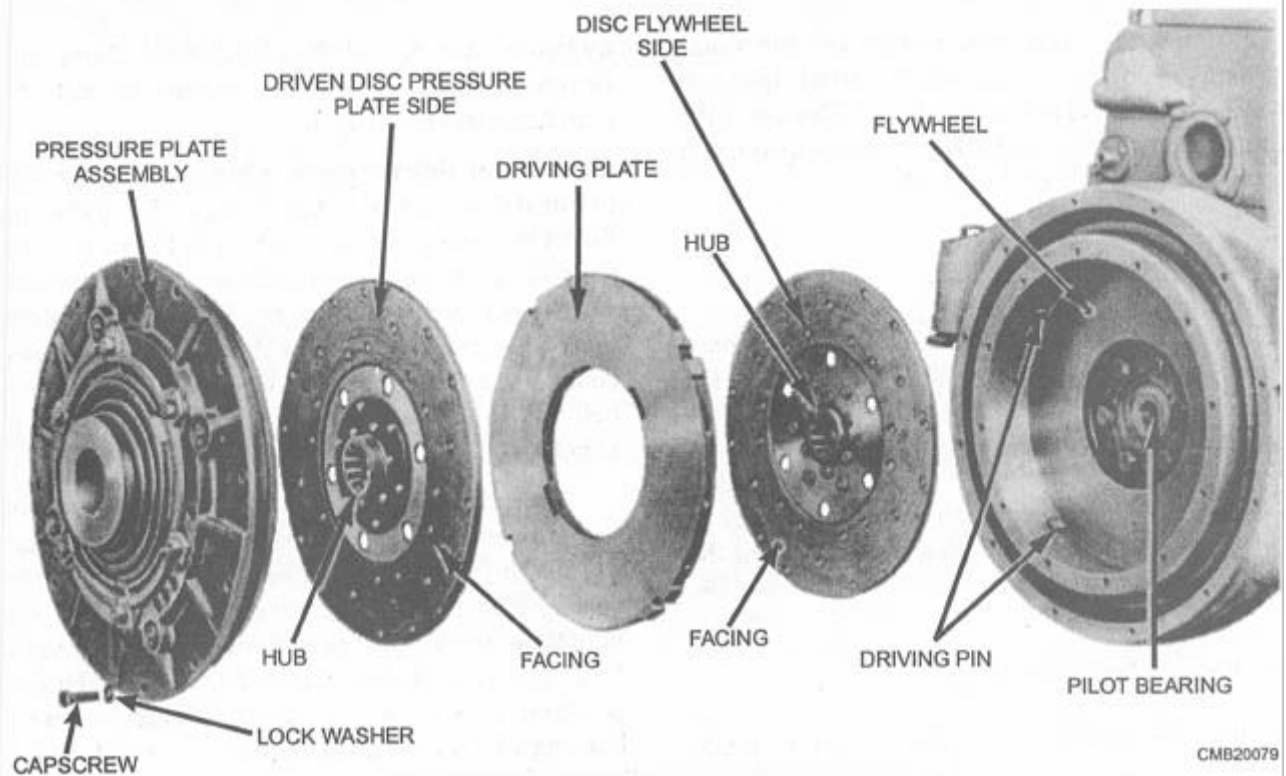

Figure 4-2.—Double-disc clutch, exploded view.

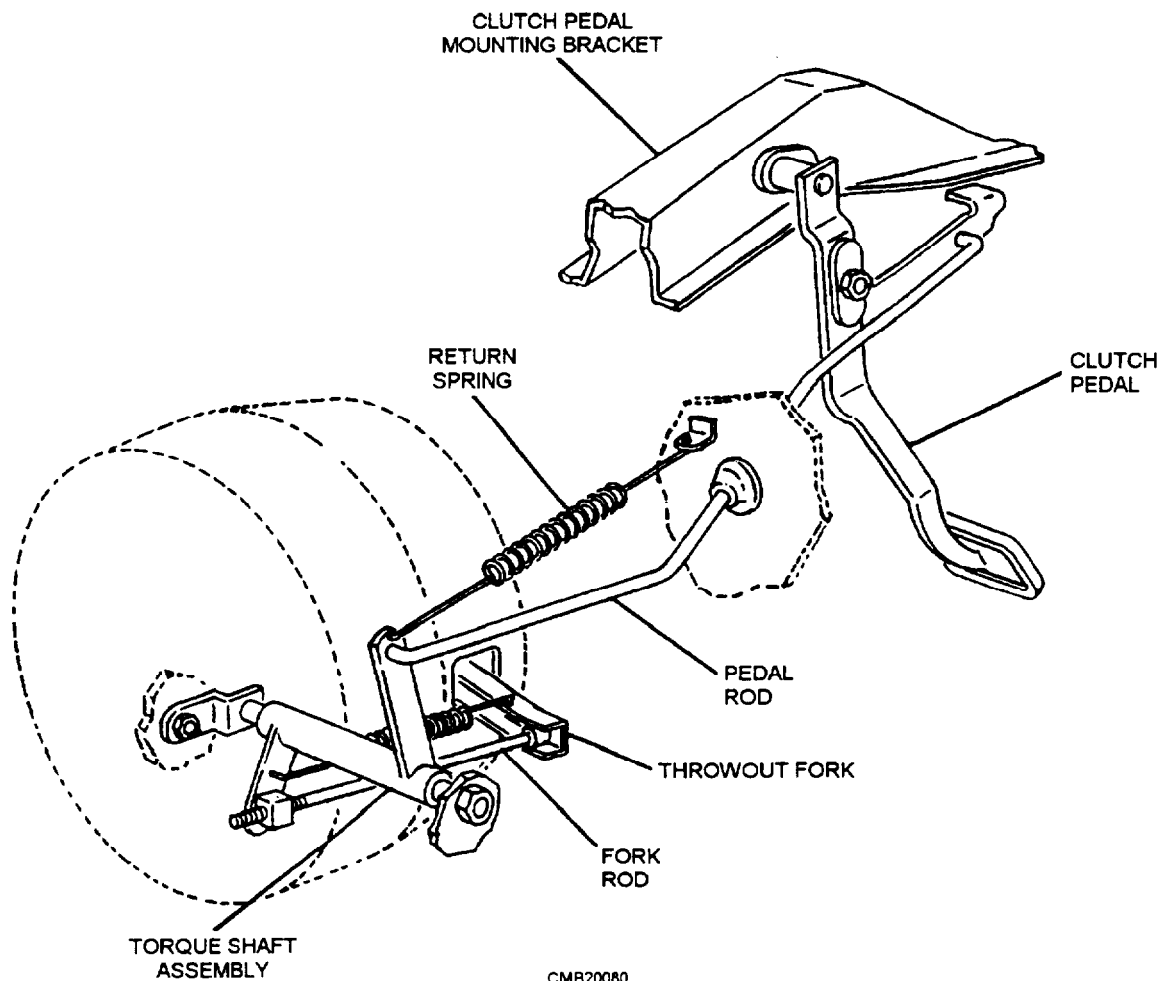

Figure 4-3.—Clutch linkage mechanism.

The operating principles, component functions, and maintenance requirements are essentially the same for each of the three clutches mentioned. This being the case, the single-disc clutch will be used to acquaint you with the fundamentals of the clutch.

## CLUTCH CONSTRUCTION

The clutch is the first drive train component powered by the engine crankshaft. The clutch lets the driver control power flow between the engine and the transmission or transaxle. Before understanding the operation of a clutch, you must first become familiar with the parts and their function. This information is very useful when learning to diagnose and repair the clutch assembly.

### Clutch Release Mechanism

A clutch release mechanism allows the operator to operate the clutch. Generally, it consists of the clutch pedal assembly, either mechanical linkage, cable, or

hydraulic circuit, and the clutch fork. Some manufacturers include the release bearing as part of the clutch release mechanism.

A **clutch linkage mechanism** uses levers and rods to transfer motion from the clutch pedal to the clutch fork. One configuration is shown in figure 4-3. When the pedal is pressed, a pushrod shoves on the bell crank and the bell crank reverses the forward movement of the clutch pedal. The other end of the bell crank is connected to the release rod. The release rod transfers bell crank movement to the clutch fork. It also provides a method of adjustment for the clutch.

The **clutch cable mechanism** uses a steel cable inside a flexible housing to transfer pedal movement to the clutch fork. As shown in figure 4-4, the cable is usually fastened to the upper end of the clutch pedal, with the other end of the cable connecting to the clutch fork. The cable housing is mounted in a stationary position. This allows the cable to slide inside the housing whenever the clutch pedal is moved. One end of the clutch cable housing has a threaded sleeve for clutch adjustment.

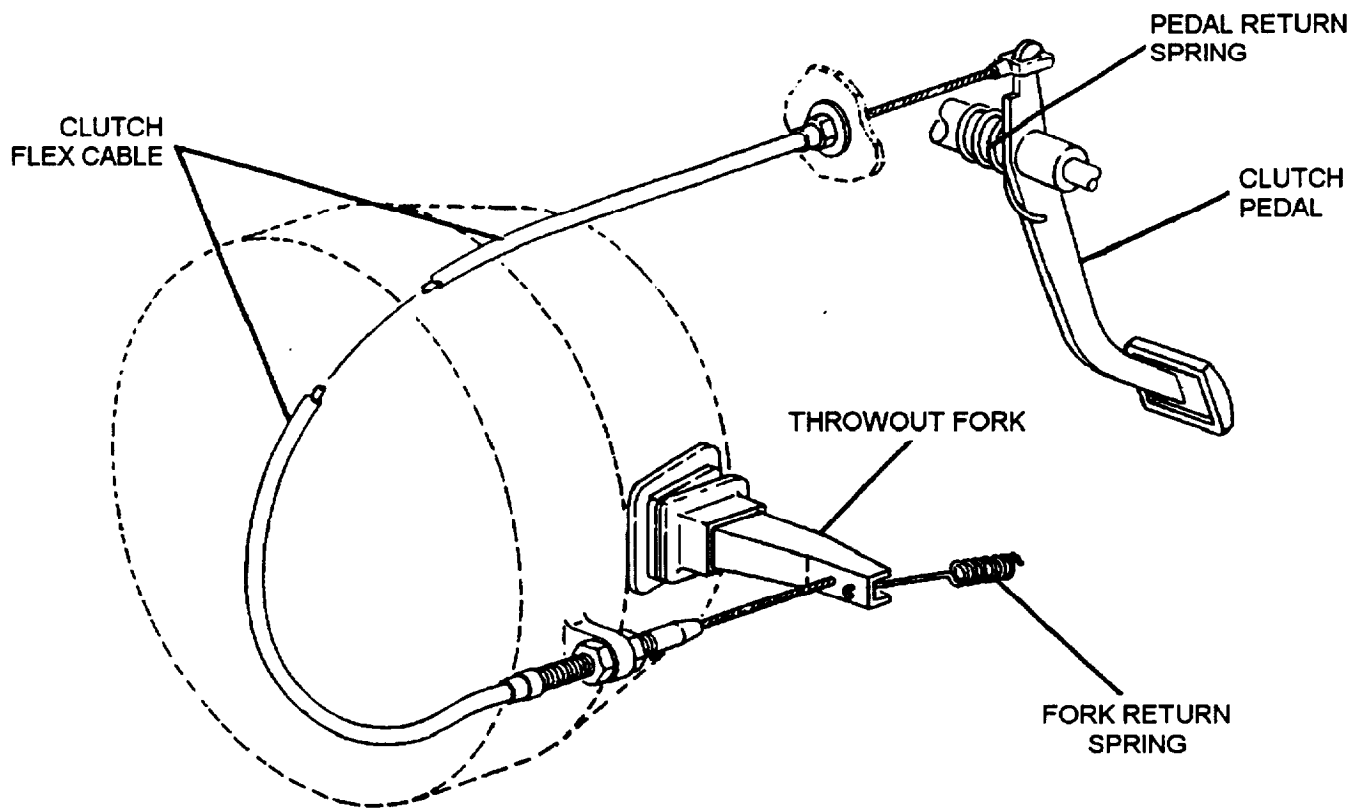

CMB20081

Figure 4-4.—Clutch cable mechanism.

A **hydraulic clutch release mechanism** (fig. 4-5) uses a simple hydraulic circuit to transfer clutch pedal action to the clutch fork. It has three basic parts—master cylinder, hydraulic lines, and a slave cylinder.

Movement of the clutch pedal creates hydraulic pressure in the master cylinder, which actuates the slave cylinder. The slave cylinder then moves the clutch fork.

### Clutch Fork

The clutch fork, also called a clutch arm or release arm, transfers motion from the release mechanism to the release bearing and pressure plate. The clutch fork sticks through a square hole in the bell housing and mounts on a pivot. When the clutch fork is moved by the release mechanism, it PRIES on the release bearing to disengage the clutch.

A rubber boot fits over the clutch fork. This boot is designed to keep road dirt, rocks, oil, water, and other debris from entering the clutch housing.

### Clutch Housing

The clutch housing is also called the bell housing. It bolts to the rear of the engine, enclosing the clutch

assembly, with the manual transmission bolted to the back of the housing. The lower front of the housing has a metal cover that can be removed for fly-wheel ring gear inspection or when the engine must be separated from the clutch assembly. A hole is provided in the side of the housing for the clutch fork. It can be made of aluminum, magnesium, or cast iron.

### Release Bearing

The release bearing, also called the throw-out bearing, is a ball bearing and collar assembly. It reduces friction between the pressure plate levers and the release fork. The release bearing is a sealed unit pack with a lubricant. It slides on a hub sleeve extending out from the front of the manual transmission or transaxle.

The release bearing snaps over the end of the clutch fork. Small spring clips hold the bearing on the fork. Then fork movement in either direction slides the release bearing along the transmission hub sleeve.

### Pressure Plate

The pressure plate is a spring-loaded device that can either engage or disengage the clutch disc and the flywheel. It bolts to the flywheel. The clutch disc fits

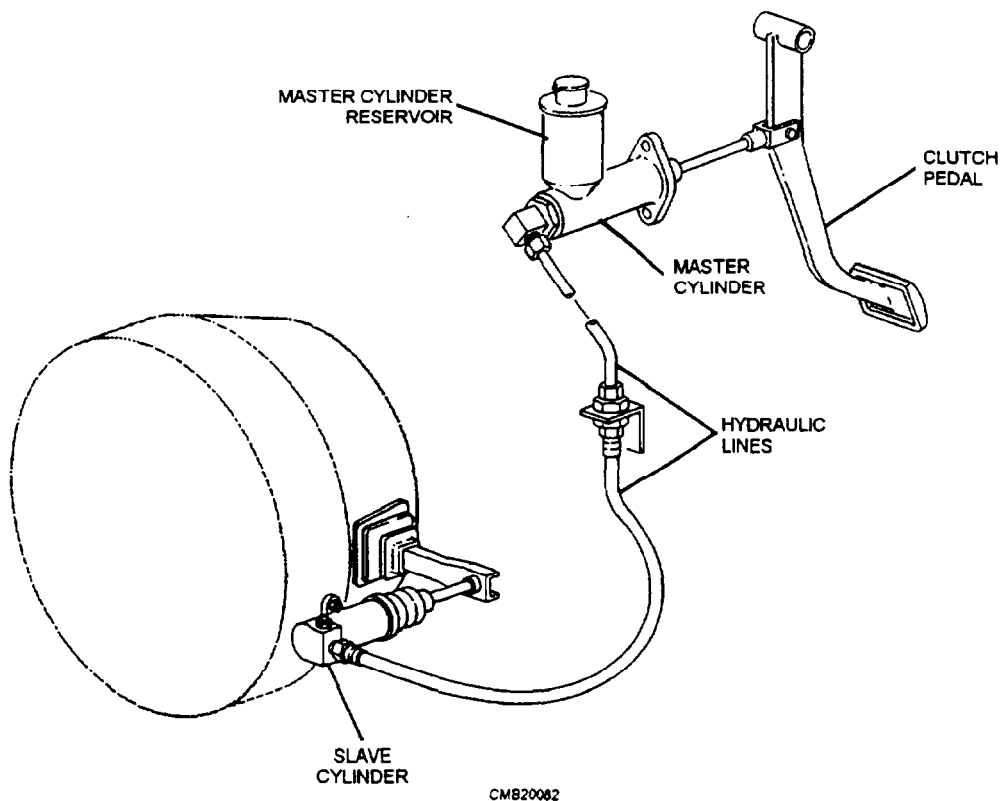

Figure 4-5.—Hydraulic clutch release mechanism.



between the flywheel and the pressure plate. There are two types of pressure plates—the coil spring type and the diaphragm type.

**Coil spring pressure plate** uses small coil springs similar to valve springs (fig. 4-6). The face of the pressure plate is a large, flat ring that contacts the clutch disc during clutch engagement. The backside of the pressure plate has pockets for the coil springs and brackets for hinging the release levers. During clutch action, the pressure plate moves back and forth inside the clutch cover. The release levers are hinged inside the pressure plate to pry on and move the pressure plate face away from the clutch disc and flywheel. Small clip-type springs fit around the release levers to keep them rattling when fully released. The pressure plate

cover fits over the springs, the release levers, and the pressure plate face. Its main purpose is to hold the assembly together. Holes around the outer edge of the cover are for bolting the pressure plate to the flywheel.

**Diaphragm pressure plate** (fig. 4-7) uses a single diaphragm spring instead of coil springs. This type of pressure plate functions similar to that of the coil spring type. The diaphragm spring is a large, round disc of spring steel. The spring is bent or dished and has pie-shaped segments running from the outer edge to the center. The diaphragm spring is mounted in the pressure plate with the outer edge touching the back of the pressure plate face. The outer rim of the diaphragm is secured to the pressure plate and is pivoted on rings (pivot rings) approximately 1 inch from the outer edge.

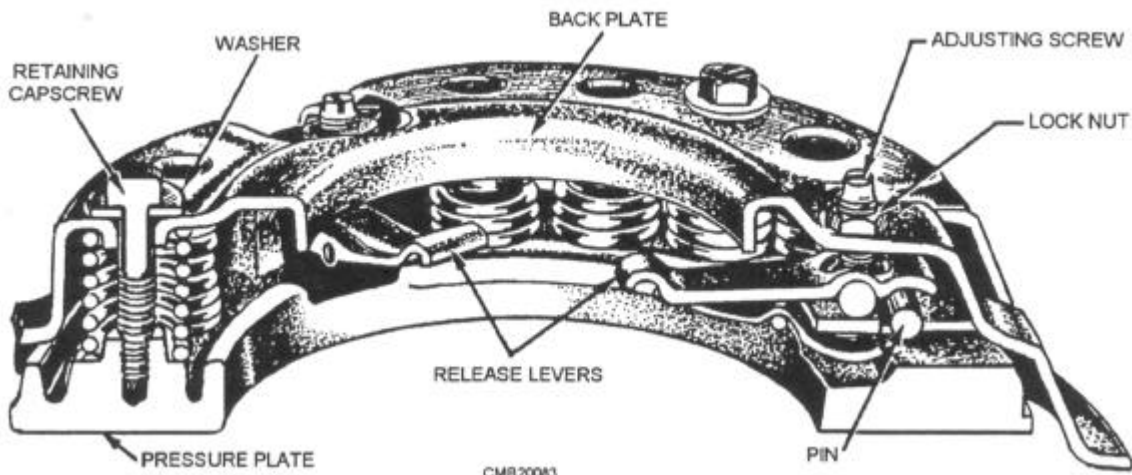

Figure 4-6.—Coil spring pressure plate.

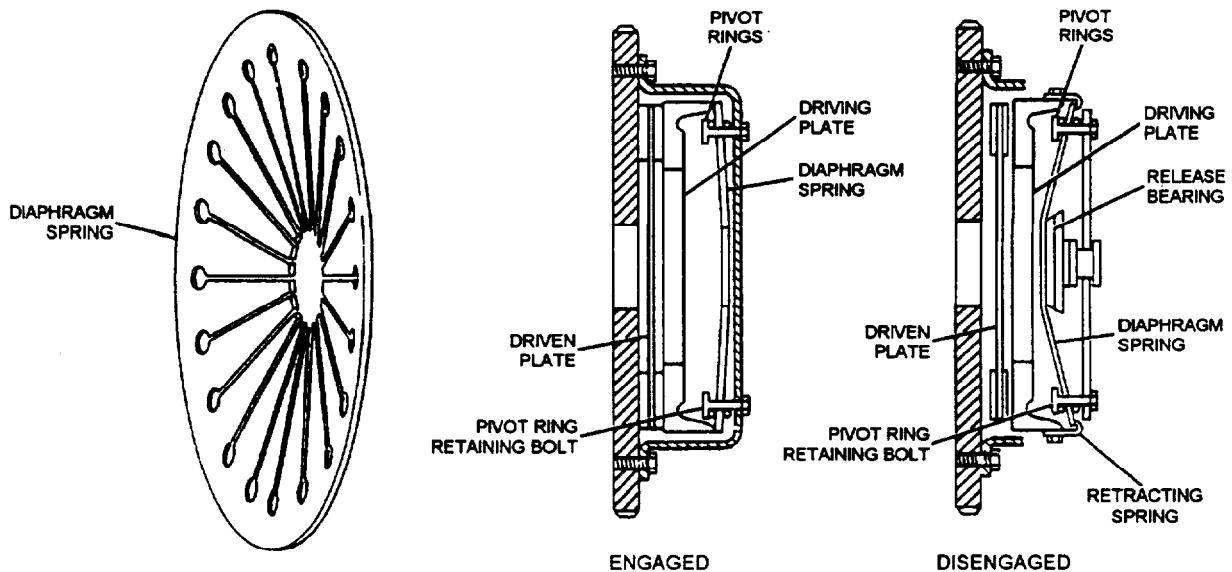

Figure 4-7.—Diaphragm pressure plate operation.

Application of pressure at the inner section of the diaphragm will cause the outer rim to move away from the flywheel and draw the pressure plate away from the clutch disc, disengaging the clutch.

### Clutch Disc

The clutch disc, also called friction lining, consists of a splined hub and a round metal plate covered with friction material (lining). The splines in the center of the clutch disc mesh with the splines on the input shaft of the manual transmission. This makes the input shaft and disc turn together. However, the disc is free to slide back and forth on the shaft.

Clutch disc **torsion springs**, also termed **damping springs**, absorb some of the vibration and shock produced by clutch engagement. They are small coil springs located between the clutch disc splined hub and the friction disc assembly. When the clutch is engaged, the pressure plate jams the stationary disc against the spinning flywheel. The torsion springs compress and soften, as the disc first begins to turn with the flywheel.

Clutch disc **facing springs**, also called the **cushioning springs**, are flat metal springs located under the friction lining of the disc. These springs have a slight wave or curve, allowing the lining to flex inward slightly during initial engagement. This also allows for smooth engagement.

The clutch disc **friction material**, also called **disc lining** or **facing**, is made of heat-resistant asbestos, cotton fibers, and copper wires woven or molded together. Grooves are cut into the friction material to aid cooling and release of the clutch disc. Rivets are used to bond the friction material to both sides of the metal body of the disc.

### Flywheel

The flywheel is the mounting surface for the clutch. The pressure plate bolts to the flywheel face. The clutch disc is clamped and held against the flywheel by the spring action of the pressure plate. The face of the flywheel is precision machined to a smooth surface. The face of the flywheel that touches the clutch disc is made of iron. Even if the flywheel were aluminum, the face is iron because it wears well and dissipates heat better.

### Pilot Bearing

The pilot bearing or bushing is pressed into the end of the crankshaft to support the end of the transmission input shaft. The pilot bearing is a solid bronze bushing, but it also may be a roller or ball bearing.

The end of the transmission input shaft has a small journal machined on its end. This journal slides inside the pilot bearing. The pilot bearing prevents the transmission shaft and clutch disc from wobbling up and down when the clutch is released. It also assists the input shaft center the disc on the flywheel.

### CLUTCH OPERATION

When the operator presses the clutch pedal, the clutch release mechanism pulls or pushes on the clutch release lever or fork (fig. 4-8). The fork moves the release bearing into the center of the pressure plate, causing the pressure plate to pull away from the clutch disc releasing the disc from the flywheel. The engine crankshaft can then turn without turning the clutch disc and transmission input shaft.

When the operator releases the clutch pedal, spring pressure inside the pressure plate pushes forward on the clutch disc (fig. 4-8). This action locks the

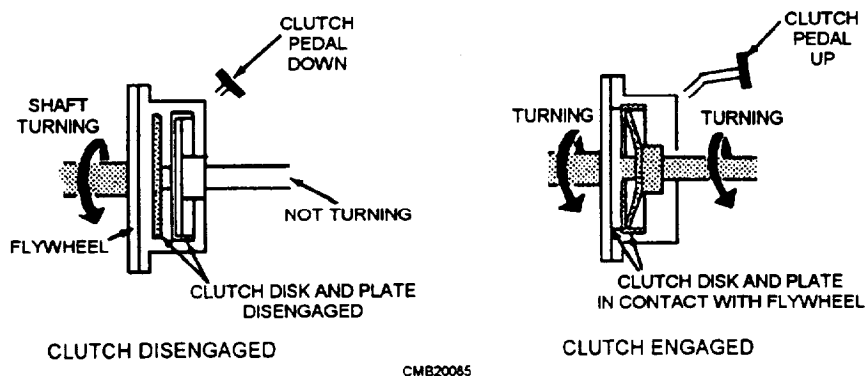

Figure 4-8.—Clutch operation.

flywheel, the clutch disc, the pressure plate, and the transmission input shaft together. The engine again rotates the transmission input shaft, the transmission gears, the drive train, and the wheels of the vehicle.

### CLUTCH START SWITCH

Many of the newer vehicles incorporate a clutch start switch into the starting system. The clutch start switch is mounted on the clutch pedal assembly. The clutch start switch prevents the engine from cranking unless the clutch pedal is depressed fully. This serves as a safety device that keeps the engine from possibly starting while in gear. Wires from the ignition switch feeds starter solenoid current through the switch. Unless the switch is closed (clutch pedal depressed), the switch prevents current from reaching the starter solenoid. With the transmission in neutral, the clutch start switch is bypassed so the engine will crank and start.

### CLUTCH ADJUSTMENT

Clutch adjustments are made to compensate for wear of the clutch disc lining and linkage between the clutch pedal and the clutch release lever. This involves setting the correct amount of free play in the release mechanism. Too much free play causes the clutch to

drag during clutch disengagement. Too little free play causes clutch slippage. It is important for you to know how to adjust the three types of clutch release mechanisms.

### Clutch Linkage Adjustment

Mechanical clutch linkage is adjusted at the release rod going to the release fork (fig. 4-9). One end of the release rod is threaded. The effective length of the rod can be increased to raise the clutch pedal (decrease free travel). It can also be shortened to lower the clutch pedal (increase free travel).

To change the clutch adjustment, loosen the release rod nuts. Turn the release rod nuts on the threaded rod until you have reached the desired free pedal travel.

### Clutch Cable Adjustment

Like the mechanical linkage, a clutch cable adjustment may be required to maintain the correct pedal height and free travel. Typically the clutch cable will have an adjusting nut. When the nut is turned, the length of the cable housing increases or decreases. To increase clutch pedal free travel, turn the clutch cable housing nut to shorten the housing, and, to decrease

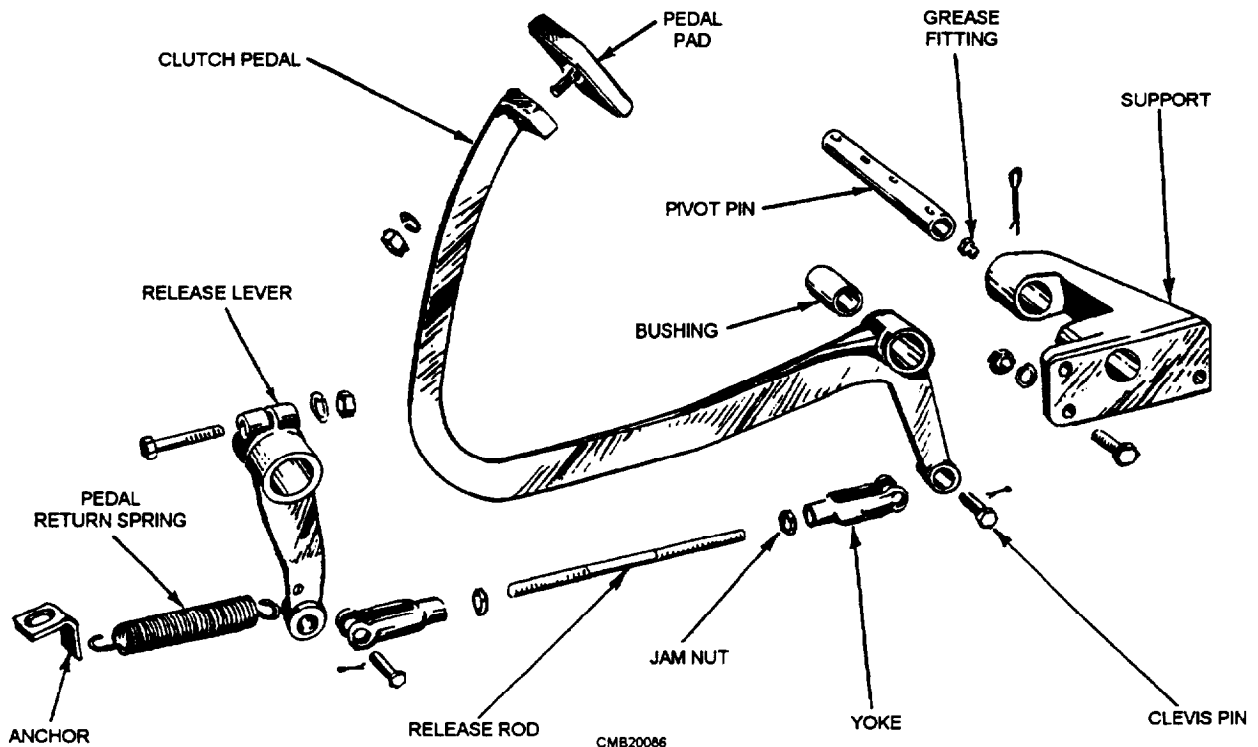

Figure 4-9.—Clutch pedal and linkage.

clutch pedal free travel, turn the nut to lengthen the housing.

### Hydraulic Clutch Adjustment

The hydraulically operated clutch shown in figure 4-10 is adjusted by changing the length of the slave cylinder pushrod. To adjust a hydraulic clutch, simply turn the nut or nuts on the pushrod as needed.

#### NOTE

When a clutch adjustment is made, refer to the manufacturer's service manual for the correct method of adjustment and clearance. If no manuals are available, an adjustment that

allows 1 1/2 inches of clutch pedal free travel will allow adequate clutch operation until the vehicle reaches the shop and manuals are available.

### CLUTCH TROUBLESHOOTING

An automotive clutch normally provides dependable service for thousands of miles. However, stop and go traffic will wear out a clutch quicker than highway driving. Everytime a clutch is engaged, the clutch disc and other components are subjected to considerable heat, friction, and wear.

Operator abuse commonly causes premature clutch troubles. For instance, "riding the clutch"

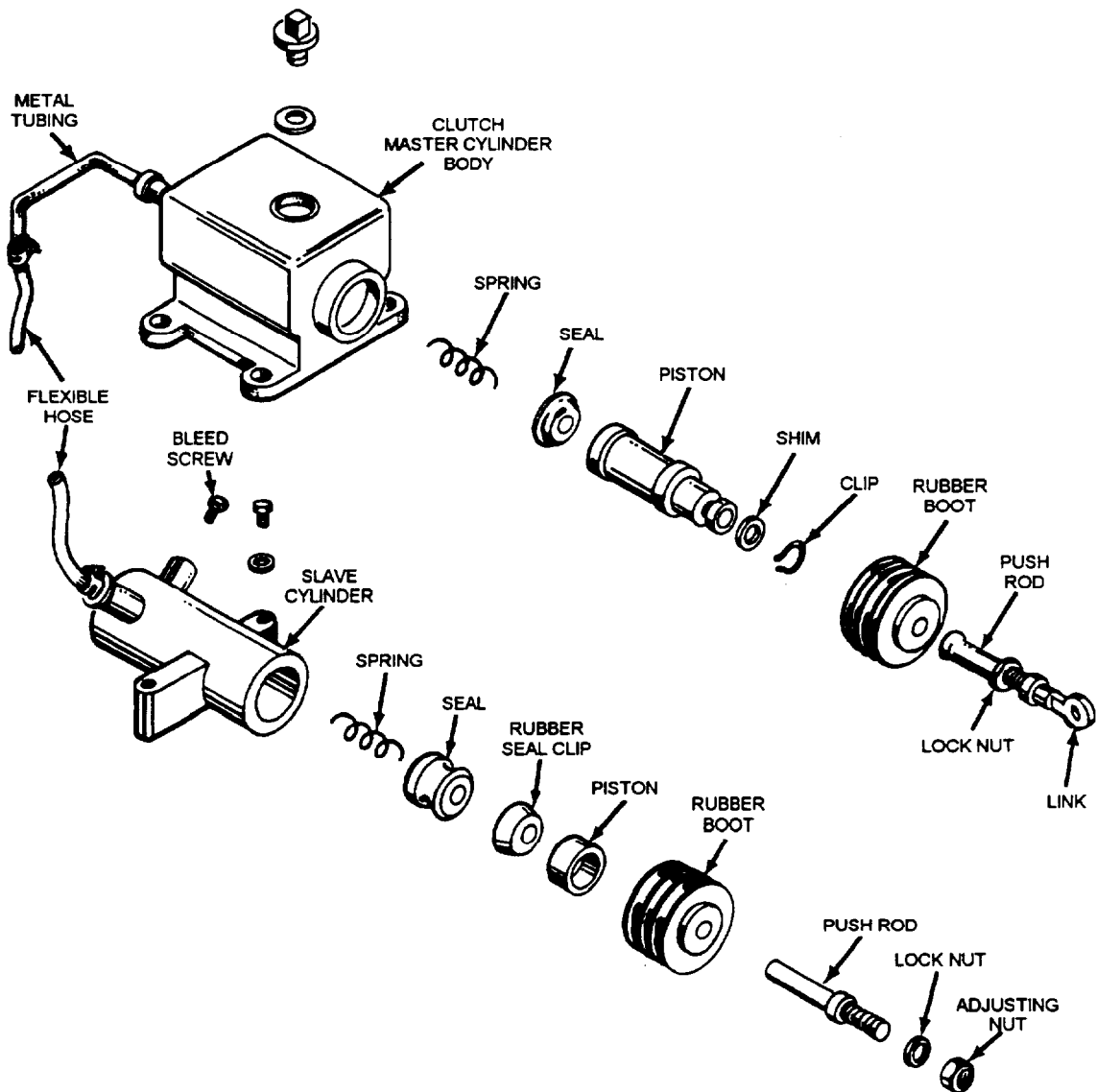

CMB20087

Figure 4-10.—Master cylinder, slave cylinder, and connections for a typical hydraulic clutch.

(overslipping clutch upon acceleration), resting your foot on the clutch pedal while driving, and other driving errors can cause early clutch failure.

When a vehicle enters the shop for clutch troubles, you should test-drive the vehicle. While the vehicle is being test-driven, you should

- check the action of the clutch pedal,
- listen for unusual noises, and
- feel for clutch pedal vibrations.

Gather as much information as you can on the operation of the clutch. Use this information, your knowledge of clutch principles, and a service manual-troubleshooting chart to determine which components are faulty.

There are five types of clutch problems—slipping, grabbing, dragging, abnormal noises, and vibration. It is important to know the symptoms produced by these problems and the parts that might be the cause.

### **Slipping**

Slipping occurs when the driven disc fails to rotate at the same speed as the driving members when the clutch is fully engaged. This condition results whenever the clutch pressure plate fails to hold the disc tight against the face of the flywheel. If clutch slippage is severe, the engine speed will rise rapidly on acceleration, while the vehicle gradually increases in speed. Slight but continuous slippage may go unnoticed until the clutch facings are ruined by excessive temperature caused by friction.

Normal wear of the clutch lining causes the free travel of the clutch linkage to decrease, creating the need for adjustment. Improper clutch adjustment can cause slippage by keeping the release bearing in contact with the pressure plate in the released position. Even with your foot off the pedal, the release mechanism will act on the clutch fork and release bearing.

Some clutch linkages are designed to allow only enough adjustment to compensate for the lining to wear close to the rivet heads. This prevents damage to the flywheel and pressure plate by the rivets wearing grooves in their smooth surfaces.

Other linkages will allow for adjustment after the disc is worn out. When in doubt whether the disc is worn excessively, remove the inspection cover on the clutch housing and visually inspect the disc.

Binding linkage prevents the pressure plate from exerting its full pressure against the disc, allowing it to slip. Inspect the release mechanism for rusted, bent, misaligned, sticking, or damaged components. Wiggle the release fork to check for free play. These problems result in slippage.

A broken motor mount (engine mount) can cause clutch slippage by allowing the engine to move, binding the clutch linkage. Under load, the engine can lift up in the engine compartment, shifting the clutch linkage and pushing on the release fork.

Grease and oil on the disc will also cause slippage. When this occurs, locate and stop any leakage, thoroughly clean the clutch components, and replace the clutch disc. This is the only remedy.

If clutch slippage is **NOT** caused by a problem with the clutch release mechanism, then the trouble is normally inside the clutch. You have to remove the transmission and clutch components for further inspection. Internal clutch problems, such as weak springs and bent or improperly adjusted release levers, will prevent the pressure plate from applying even pressure. This condition allows the disc to slip.

To test the clutch for slippage, set the emergency brake and start the engine. Place the transmission or transaxle in high gear. Then try to drive the vehicle forward by slowly releasing the clutch pedal. A clutch in good condition should lock up and immediately kill the engine. A badly slipping clutch may allow the engine to run, even with the clutch pedal fully released. Partial clutch slippage could let the engine run momentarily before stalling.

### **NOTE**

Never let a clutch slip for more than a second or two. The extreme heat generated by slippage will damage the flywheel and pressure plate faces.

### **Grabbing**

A grabbing or chattering clutch will produce a very severe vibration or jerking motion when the vehicle is accelerated from a standstill. Even when the operator slowly releases the clutch pedal, it will seem like the clutch pedal is being pumped rapidly up and down. A loud bang or chattering may be heard, as the vehicle body vibrates.

Clutch grabbing and chatter is caused by problems with components inside the clutch housing (friction

disc, flywheel, or pressure plate). Other reasons for a grabbing clutch could be due to oil or grease on the disc facings, glazing, or loose disc facings. Broken parts in the clutch, such as broken disc facings, broken facing springs, or a broken pressure plate, will also cause grabbing.

There are several things outside of the clutch that will cause a clutch to grab or chatter when it is being engaged. Loose spring shackles or U-bolts, loose transmission mounts, and worn engine mounts are among the items to be checked. If the clutch linkage binds, it may release suddenly to throw the clutch into quick engagement, resulting in a heavy jerk. However, if all these items are checked and found to be in good condition, the trouble is inside the clutch itself and will have to be removed for repair.

### **Dragging**

A dragging clutch will make the transmission or transaxle grind when trying to engage or shift gears. This condition results when the clutch disc does not completely disengage from the flywheel or pressure plate when the clutch pedal is depressed. As a result, the clutch disc tends to continue turning with the engine and attempts to drive the transmission.

The most common cause of a dragging clutch is too much clutch pedal free travel. With excessive free travel, the pressure plate will not fully release when the clutch pedal is pushed to the floor. Always check the clutch adjustments first. If adjustment of the linkage does not correct the trouble, the problem is in the clutch, which must be removed for repair.

On the inside of the clutch housing, you will generally find a warped disc or pressure plate, oil or grease on the friction surface, rusted or damaged transmission input shaft, or improper adjustment of the pressure plate release levers causing the problem.

### **Abnormal Noises**

Faulty clutch parts can make various noises. When an operator reports that a clutch is making noise, find out when the noise is heard. Does the sound occur when the pedal is moved, when in neutral, when in gear, or when the pedal is held to the floor? This will assist you in determining which parts are producing these noises.

An operator reports hearing a scraping, clunking, or squeaking sound when the clutch pedal is moved up or down. This is a good sign of a worn or unlubricated

clutch release mechanism. With the engine off, pump the pedal and listen for the sound. Once the source of the sound is located, you should clean, lubricate, or replace the parts as required.

Sounds produced from the clutch, when the clutch is initially ENGAGED, are generally due to friction disc problems, such as a worn clutch disc facing, which causes a metal-to-metal grinding sound. A rattling or a knocking sound may be produced by weak or broken clutch disc torsion springs. These sounds indicate problems that require the removal of the transmission and clutch assembly for repair.

If clutch noises are noticeable when the clutch is DISENGAGED, the trouble is most likely the clutch release bearing. The bearing is probably either worn, binding, or, in some cases, loses its lubricant. Most clutch release bearings are factory lubricated; however, on some larger trucks and construction equipment, the bearing requires periodic lubrication. A worn pilot bearing may also produce noises when the clutch is disengaged. The worn pilot bearing can let the transmission input shaft and clutch disc vibrate up and down, causing an unusual noise.

Sounds heard in NEUTRAL, that disappear when the clutch pedal is pushed, are caused by problems inside the transmission. Many of these sounds are due to worn bearings. However, always refer to the troubleshooting chart in the manufacturer's manual.

### **Pedal Pulsation**

A pulsating clutch pedal is caused by the runout (wobble or vibration) of one of the rotating members of the clutch assembly. A series of slight movements can be felt on the clutch pedal. These pulsations are noticeable when light foot pressure is applied. This is an indication of trouble that could result in serious damage if not corrected immediately. There are several conditions that can cause these pulsations. One possible cause is misalignment of the transmission and engine.

If the transmission and engine are not in line, detach the transmission and remove the clutch assembly. Check the clutch housing alignment with the engine and crankshaft. At the same time, the flywheel can be checked for runout, since a bent flywheel or crankshaft flange will produce clutch pedal pulsation. If the flywheel does not seat on the crankshaft flange, remove the flywheel. After cleaning the crankshaft flange and flywheel, replace the flywheel, making sure a positive seat is obtained

between the flywheel and the flange. If the flange is bent, the crankshaft must be replaced.

Other causes of clutch pedal pulsation include bent or maladjusted pressure plate release levers, warped pressure plate, or warped clutch disc. If either the clutch disc or pressure plate is warped, they must be replaced.

## **CLUTCH OVERHAUL**

When adjustment or repair of the linkage fails to remedy problems with the clutch, the clutch must be removed for inspection. Any faulty parts should be discarded and replaced with new or rebuilt components. If replacement parts are not readily available, a decision to use the old components should be based on the manufacturer's recommendations and the maintenance supervisor.

Transmission or transaxle removal is required to service the clutch. Always follow the detailed directions in the service manual. To remove the clutch in a rear-wheel drive vehicle, remove the drive shaft, the clutch fork, the clutch release mechanism, and the transmission. With a front-wheel drive vehicle, the axle shafts (drive axles), the transaxle, and, in some cases, the engine must be removed for clutch repairs.

### **WARNING**

When the transmission or transaxle is removed, support the weight of the engine. Never let the engine, the transmission, or the transaxle be unsupported. The transmission input shaft, clutch fork, engine mounts, and other associated parts could be damaged.

After removal of the transmission or transaxle, remove the clutch housing from the rear of the engine. Support the housing as you remove the last bolt. Be careful not to drop the clutch housing as you pull it away from the dowel pins.

Using a hammer and a center punch, mark the pressure plate and flywheel. These marks are needed when reinstalling the same pressure plate to assure correct balancing of the clutch.

With the clutch removed, all components are to be cleaned and inspected for wear and damage. After cleaning, you should inspect the flywheel and pressure plate for signs of unusual wear, such as scoring or cracks. A straightedge should be used to check for

warpage of the pressure plate. Using a dial indicator, measure the runout of the flywheel. The pressure plate release levers should show very limited or no signs of wear from contact with the release bearing. If excessive wear, cracks, or warpage is noted on the flywheel and/or pressure plate, the assembly should be replaced. This is also a good time to inspect the ring gear teeth on the flywheel. If they are worn or chipped, a new ring gear should be installed.

### **NOTE**

Be careful how you clean the parts of the clutch. Avoid using compressed air to blow clutch dust from the parts. A clutch disc contains asbestos—a cancer-causing substance.

While inspecting the flywheel, you should check the pilot bearing in the end of the crankshaft. A worn pilot bearing will allow the transmission input shaft and clutch disc to wobble up and down. Using a telescoping gauge and a micrometer, measure the amount of wear in the bushing. For wear measurements of the pilot bearing, refer to the service manual. If a roller bearing is used, rotate them. They should turn freely and show no signs of rough movement. If replacement of the pilot bearing is required, the use of a slide hammer puller will drive the bearing out of the crankshaft end. Before installing a new pilot bearing, check the fit by sliding it over the input shaft of the transmission. Then drive the new bearing into the end of the crankshaft.

Inspect the disc for wear; inspect the depth of the rivet holes, loose rivets, and worn or broken torsion springs. Check the splines in the clutch disc hub for a "like new" condition. The clutch shaft splines should be inspected by placing the disc on the clutch shaft and sliding it over the splines. The disk should move relatively free back and forth without any unusual tightness or binding. Normally, the clutch disc is replaced anytime the clutch is tom down for repairs.

Another area to inspect is the release bearing. The release bearing and sleeve is usually sealed and factory packed (lubricated). A bad release bearing will produce a grinding noise whenever the clutch pedal is pushed down. To check the action of the release bearing, insert your fingers into the bearing; then turn the bearing while pushing on it. Try to detect any roughness; it should rotate smoothly. Also, inspect the spring clip on the release bearing or fork. If bent, worn, or fatigued, the bearing or fork must be replaced.

The last area to check before reassembly is the clutch fork. If it is bent or worn, the fork can prevent the clutch from releasing properly. Inspect both ends of the fork closely. Also, inspect the clutch fork pivot point in the clutch housing; the pivot ball or bracket should be undamaged and tight.

When a new pressure plate is installed, do not forget to check the plate for proper adjustments. These adjustments will ensure proper operation of the pressure plate. The first adjustment ensures proper movement of the pressure plate in relation to the cover. With the use of a straightedge and a scale as shown in figure 4-11, begin turning the adjusting screws until you obtain the proper clearance between the straight-edge and the plate as shown. For exact measurements, refer to the manufacturer's service manual.

The second adjustment positions the release levers and allows the release bearing to contact the levers simultaneously while maintaining adequate clearance of the levers and disc or pressure plate cover. This adjustment is known as finger height. To adjust the pressure plate, place the assembly on a flat surface and measure the height of the levers, as shown in figure 4-12. Adjust it by loosening the locknut and turning. After the proper height has been set, make sure the locknuts are locked and staked with a punch to keep them from coming loose during operations. Exact release lever height can be found in the manufacturer's service manual.

Reassemble the clutch in the reverse order of disassembly. Mount the clutch disc and pressure plate on the flywheel. Make sure the disc is facing in the right direction. Usually, the disc's offset center (hub and torsion springs) fit into the pressure plate.

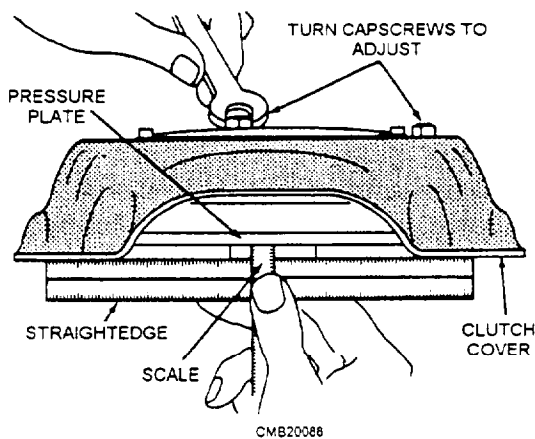

Figure 4-11.—Pressure plate adjustment.

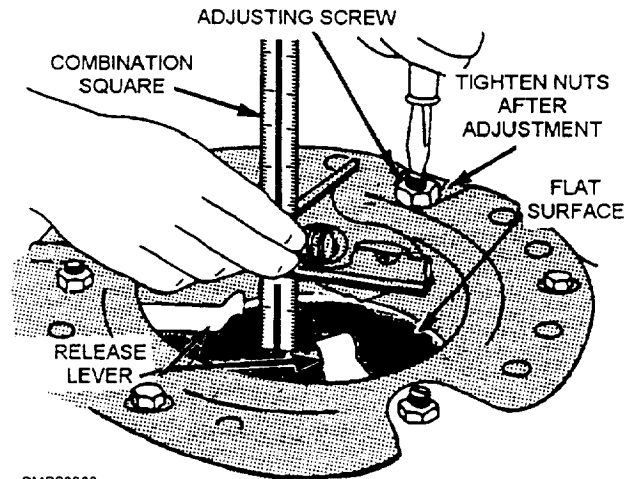

Figure 4-12.—Pressure plate release lever adjustment.

If reinstalling, the old pressure plate lines up the alignment marks made before disassembly. Start all of the pressure plates bolts by hand. Never replace a clutch pressure plate bolt with a weaker bolt. Always install the special case-hardened bolt recommended by the manufacturer.

Use a clutch alignment tool to center the clutch disc on the flywheel. If an alignment tool is unavailable, an old clutch shaft from the same type of vehicle may be used. Tighten each pressure plate bolt a little at a time in a **crisscross pattern**. This will apply equal pressure on each bolt, as the pressure plate spring(s) are compressed. When the bolts are snugly in place, torque them to the manufacturer's specifications found in the service manual. Once the pressure plates bolts are torqued to specs, slide out the alignment tool. Without the clutch disc being centered, it is almost impossible to install the transmission or transaxle.

Next install the clutch fork and release bearing in the clutch housing. Fit the clutch housing over the rear of the engine. Dowels are provided to align the housing on the engine. Install and tighten the bolts in a crisscross manner.

Install the transmission and drive shaft or the transaxle and axle shafts. Reconnect the linkages, the cables, any wiring, the battery, and any other parts required for disassembly. After all parts have been installed, adjust the clutch pedal free travel as prescribed by the manufacturer and test-drive the vehicle for proper operation.

## REVIEW 1 QUESTIONS

Q1. What is the function of the automotive clutch?



- Q2. *What component(s) allow(s) the operator to operate the clutch?*
- Q3. *What component(s) transfer(s) motion from the release mechanism to the release bearing and pressure plate?*
- Q4. *What component(s) within the clutch disc absorb(s) vibration and shock produced by clutch engagement?*
- Q5. *What component prevents the engine starting unless the clutch pedal is fully depressed?*
- Q6. *If no service manual is available and an adjustment of the clutch is required, what amount of clutch pedal free travel will allow adequate clutch operation?*

## MANUAL TRANSMISSIONS

**Learning Objective:** State the operating principles, identify the components, and maintenance of a manual transmission.

A manual transmission is designed with two purposes in mind. One purpose of the transmission is providing the operator with the option of maneuvering the vehicle in either the forward or reverse direction. This is a basic requirement of all automotive vehicles. Almost all vehicles have multiple forward gear ratios, but, in most cases, only one ratio is provided for reverse.

Another purpose of the transmission is to provide the operator with a selection of gear ratios between engine and wheel so that the vehicle can operate at the best efficiency under a variety of operating conditions and loads. If in proper operating condition, a manual transmission should do the following:

- Be able to increase torque going to the drive wheel for quick acceleration.
- Supply different gear ratios to match different engine load conditions.
- Have a reverse gear for moving the vehicle backwards.
- Provide the operator with an easy means of shifting transmission gears.

- Operate quietly with minimum power loss.

## TRANSMISSION CONSTRUCTION

Before understanding the operation and power flow through a manual transmission, you first must understand the construction of the transmission. This is necessary for you to be able to diagnose and repair damaged transmissions properly.

### Transmission Case

The transmission case provides support for the bearings and shafts, as well as an enclosure for lubricating oil. A manual transmission case is cast from either iron or aluminum. Because they are lighter in weight, aluminum cases are preferred.

A drain plug and fill plug are provided for servicing. The drain plug is located on the bottom of the case, whereas the fill plug is located on the side.

### Extension Housing

Also known as the tail shaft, the extension housing bolts to the rear of the transmission case. It encloses and holds the transmission output shaft and rear oil seal. A gasket is used to seal the mating surfaces between the transmission case and the extension housing. On the bottom of the extension housing is a flange that provides a base for the transmission mount.

### Front Bearing Hub

Sometimes called the front bearing cap, the bearing hub covers the front transmission bearing and acts as a sleeve for the clutch release bearing. It bolts to the transmission case and a gasket fits between the front hub and the case to prevent oil leakage.

### Transmission Shafts

A manual transmission has four steel shafts mounted inside the transmission case. These shafts are the input shaft, the countershaft, the reverse idler shaft, and the main shaft.

**INPUT SHAFT.**—The input shaft, also known as the clutch shaft, transfers rotation from the clutch disc

to the countershaft gears (fig. 4-13). The outer end of the shaft is splined except the hub of the clutch disc. The inner end has a machined gear that meshes with the countershaft. A bearing in the transmission case supports the input shaft in the case. Anytime the clutch disc turns, the input shaft gear and gears on the countershaft turn.

**COUNTERSHAFT.**—The countershaft, also known as the *cluster gear shaft*, holds the countershaft gear into mesh with the input shaft gear and other gears in the transmission (fig. 4-14). It is located slightly below and to one side of the clutch shaft. The countershaft does not turn in the case. It is locked in place by either a steel pin, force fit, or locknuts.

**REVERSE IDLER SHAFT.**—The *reverse idler shaft* is a short shaft that supports the reverse idle gear

(fig. 4-15). It mounts stationary in the transmission case about halfway between the countershaft and output shaft, allowing the reverse idle gear to mesh with both shafts.

**MAIN SHAFT.**—The main shaft, also called the *output shaft*, holds the output gears and synchronizers (fig. 4-16). The rear of the shaft extends to the rear of the extension housing where it connects to the drive shaft to turn the wheel of the vehicle. Gears on the shaft are free to rotate, but the synchronizers are locked on the shaft by splines. The synchronizers will only turn when the shaft itself turns.

### Transmission Gears

Transmission gears can be classified into four groups—input gear, countershaft gears, main shaft gears, and the reverse idler gear. The input gear turns

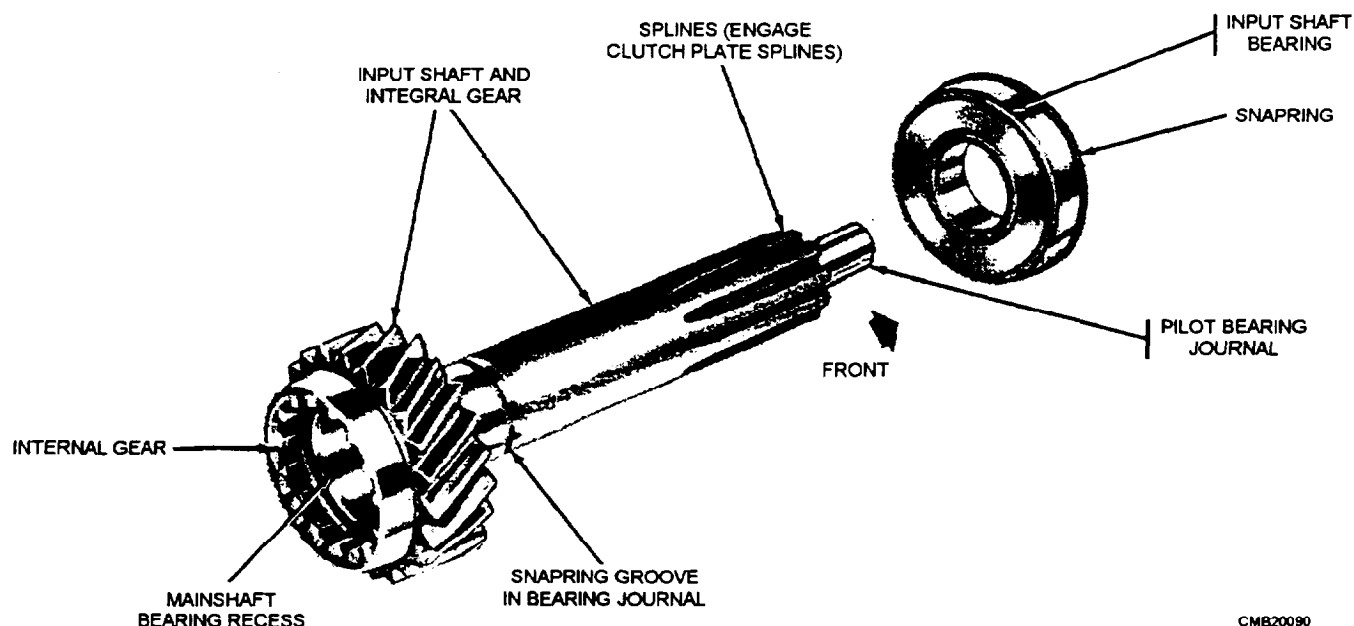

Figure 4-13.—Transmission input shaft and bearing.

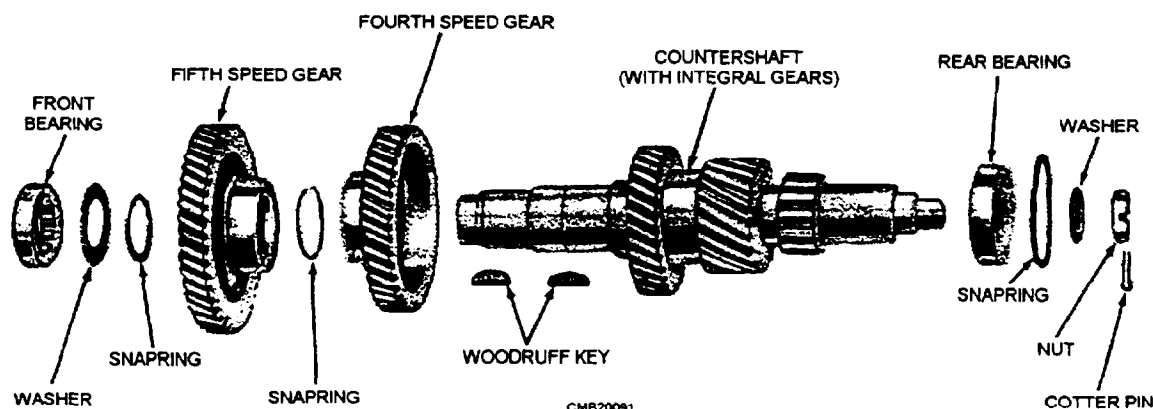

Figure 4-14.—Transmission countershaft assembly—exploded view.

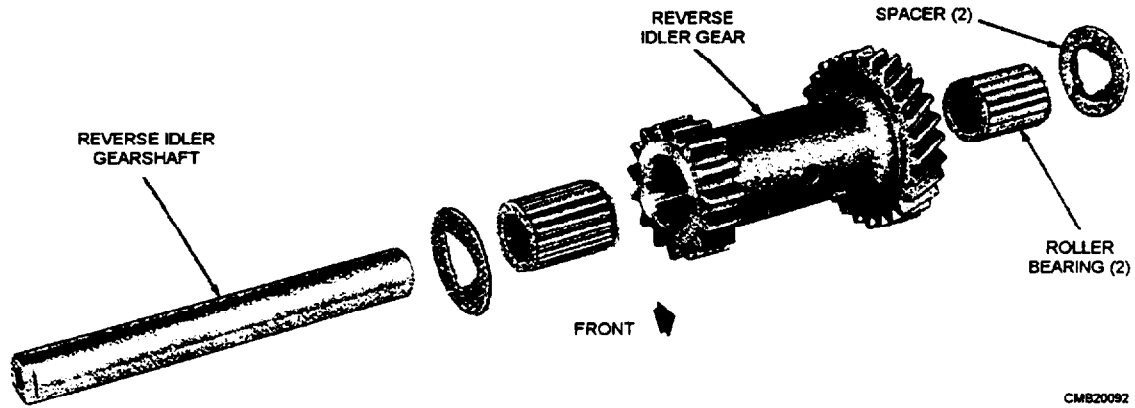

Figure 4-15.—Reverse idler shaft and gear assembly-exploded view.

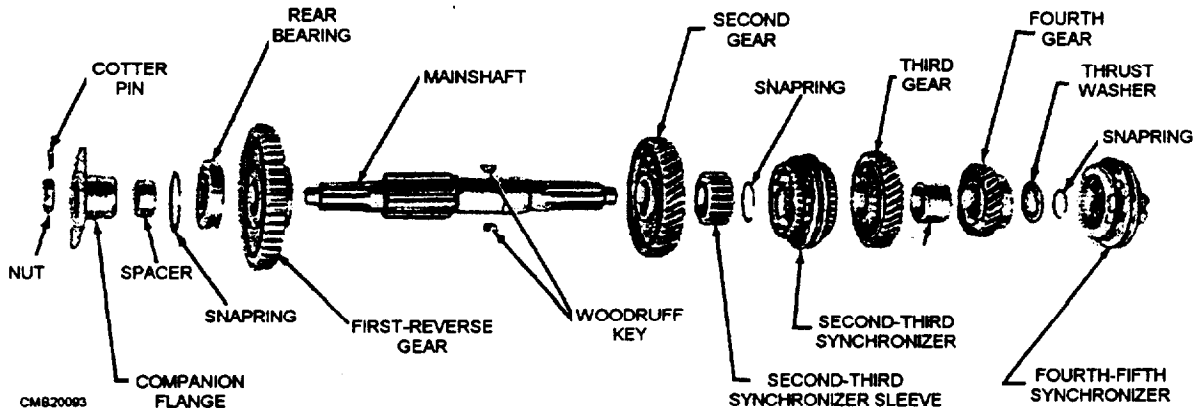

Figure 4-16.—Transmission main shaft assembly-exploded view.

the countershaft gears, the countershaft gears turns the main shaft gears, and, when engaged, the reverse idler gear.

In low gear, a small gear on the countershaft drives a larger gear on the main shaft, providing for a high gear ratio for accelerating. Then, in high gear, a larger countershaft gear turns a small main shaft gear or a gear of equal size, resulting in a low gear ratio, allowing the vehicle to move faster. When reverse is engaged, power flows from the countershaft gear, to the reverse idler gear, and to the engaged main shaft gear. This action reverses main shaft rotation.

### Synchronizers

The synchronizer is a drum or sleeve that slides back and forth on the splined main shaft by means of the shifting fork. Generally, it has a bronze cone on each side that engages with a tapered mating cone on the second and high-speed gears. A transmission synchronizer (fig. 4-17) has two functions, which are as follows:

1. Lock the main shaft gear to the main shaft.

2. Prevent the gear from clashing or grinding during shifting.

When the synchronizer is moved along the main shaft, the cones act as a clutch. Upon touching the gear that is to be engaged, the main shaft is accelerated or slowed down until the speeds of the main shaft and gear are synchronized. This action occurs during partial movement of the shift lever. Completion of lever movement then slides the sleeve and gear into complete engagement. This action can be readily understood by remembering that the hub of the sleeve slides on the splines of the main shaft to engage the cones; then the sleeve slides on the hub to engage the gears. As the synchronizer is slid against a gear, the gear is locked to the synchronizer and to the main shaft. Power can then be sent out of the transmission to the wheels.

### Shift Forks

Shift forks fit around the synchronizer sleeves to transfer movement to the sleeves from the shift

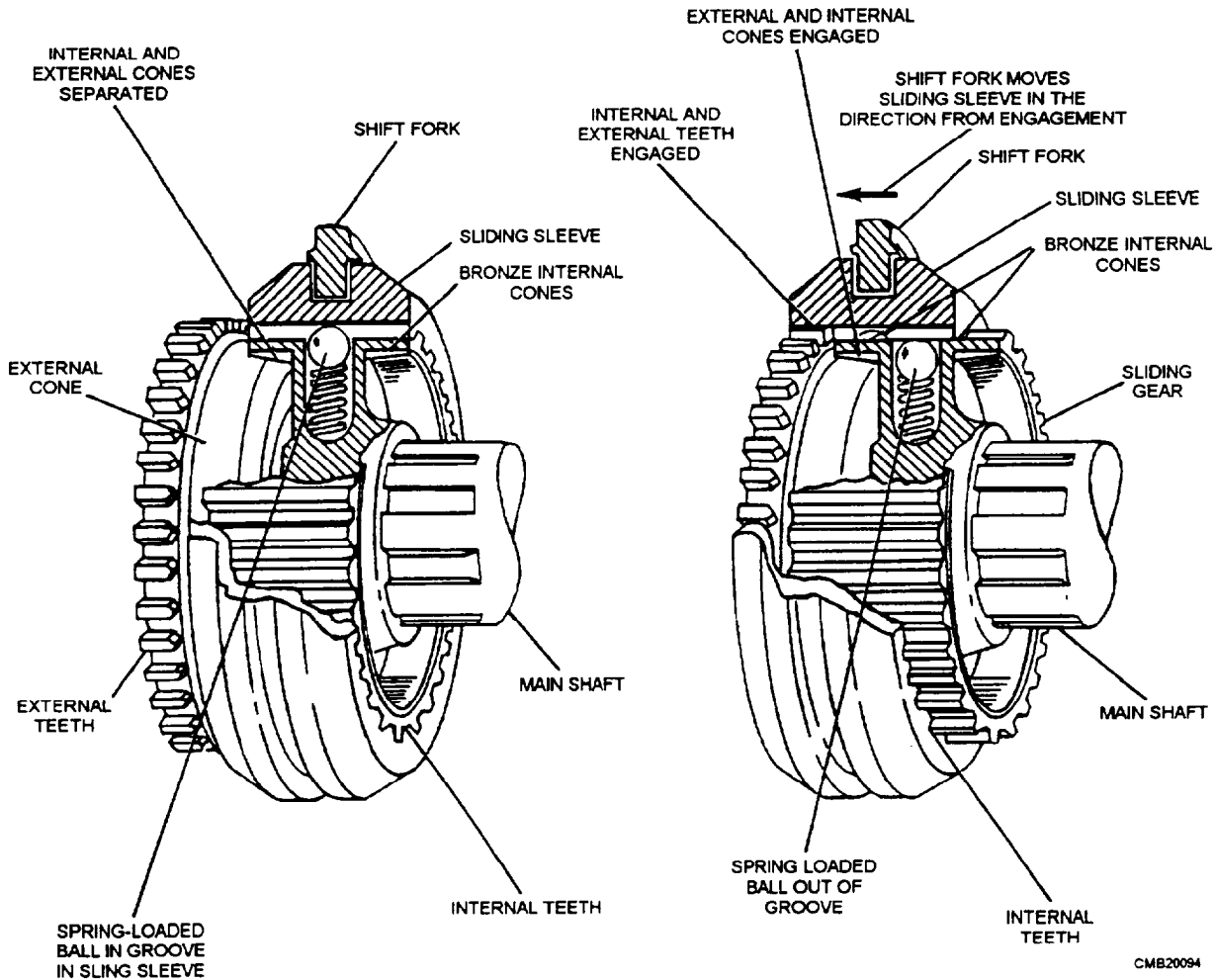

Figure 4-17.—Synchronizers.

linkage. The shift fork sets in a groove cut into the synchronizer sleeve. The linkage rod or shifting rail connects the shift fork to the operator's shift lever. As the lever moves, the linkage or rail moves the shift fork and synchronizer sleeve to engage the correct transmission gear.

### Shift Linkage and Levers

There are two types of shift linkages used on manual transmissions. They are the EXTERNAL ROD and the INTERNAL SHIFT RAIL. They both perform the same function. They connect the shift lever with the shift fork mechanism.

The transmission shift lever assembly can be moved to cause movement of the shift linkage, shift forks, and synchronizers. The shift lever may be either floor mounted or column mounted, depending upon the manufacturer. Floor-mounted shift levers are generally used with an internal shift rail linkage,

whereas column-mounted shift levers are generally used with an external rod linkage.

### TRANSMISSION TYPES

Manual transmissions are of three major types:

1. Sliding gear
2. Constant mesh
3. Synchromesh

A quick overview of the three types is as follows:

- The sliding gear transmission has two or more shafts mounted in parallel or in line, with sliding spur gears arranged to mesh with each other and provide a change in speed or direction.
- The constant mesh transmission has parallel shafts with gears in constant mesh. Shifting is done by locking free-running gears to their shaft by using sliding collars.

- The synchromesh transmission also has gears in constant mesh. However, gears can be selected without clashing or grinding by synchronizing the speeds of the mating part before they engage.

The sliding gear transmission is generally used in farm and industrial machines; therefore, we will only look closely at the constant mesh and synchromesh transmissions.

### Constant Mesh Transmission

To eliminate the noise developed by the spur-tooth gears used in the sliding gear transmission, automotive manufacturers developed the constant mesh transmission, also known as the collar shift transmission (fig. 4-18). The constant mesh transmission has parallel shafts with gears in constant mesh. In neutral,

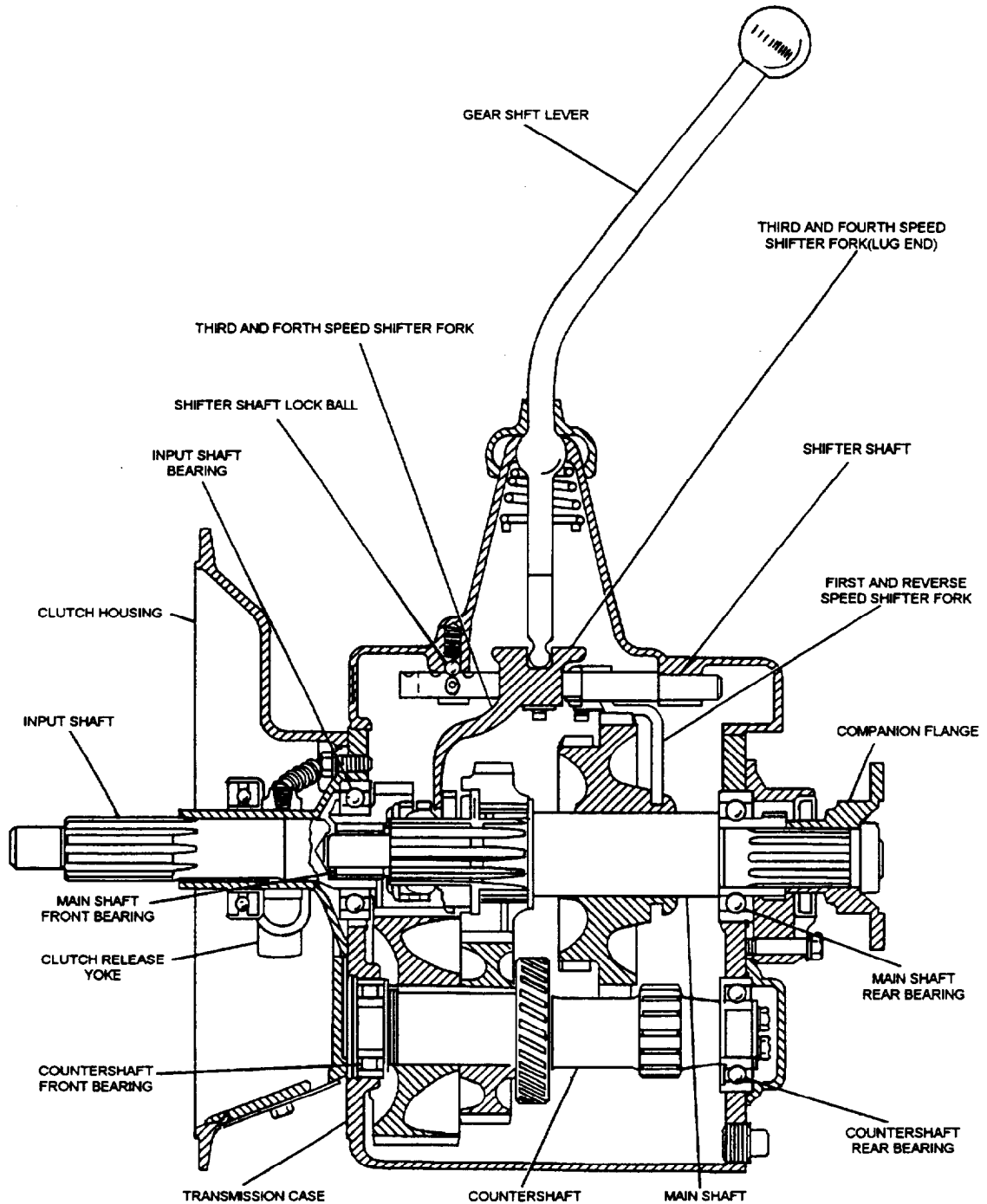

Figure 4-18.—Constant mesh transmission assembly.

CMB20095

the gears are free running but, when shifted, they are locked to their shafts by sliding collars.

The following is an example of the operation of a constant mesh transmission: When the shift lever is moved to THIRD, the THIRD and FOURTH shifter fork moves the sliding collar toward the THIRD speed gear. This engages the external teeth of the sliding collar with the internal teeth of the THIRD speed gear. Since the THIRD speed gear is meshed and rotating with the countershaft, the sliding collar must also rotate. The sliding collar is splined to the main shaft, and therefore, the main shaft rotates with the sliding collar. This principle is carried out when the shift lever moves from one speed to the next.

Constant mesh gears are seldom used for all speeds. Common practice is to use such gears for the higher gears, with sliding gears for FIRST and REVERSE, or for REVERSE only.

### Synchromesh Transmission

The construction of the synchromesh transmission is the same as that of the constant mesh transmission with the exception that a synchronizer has been added (fig. 4-19). The addition of synchronizers allows the gears to be constant mesh when the cluster gears and

the synchronizing clutch mechanisms lock the gears together.

The synchronizer accelerates or slows down the rotation of the shaft and gear, until both are rotating at the same speed and can be locked together without a gear clash. Since the vehicle is normally standing still when it is shifted into reverse gear, a synchronizer is not ordinarily used on the reverse gear.

### POWER FLOW

Now that you understand the basic parts and construction of a manual transmission, we will cover the flow of power through a five-speed synchromesh transmission. In this example neither first gear nor reverse gear are synchronized.

### Reverse Gear

In passing from neutral to reverse, the first-reverse main shaft gear is shifted rearward to mesh with the reverse idler gear (fig. 4-20, view A). The sole function of this gear is to make the main shaft rotate in the opposite direction to the input shaft; it does not affect gear ratio.

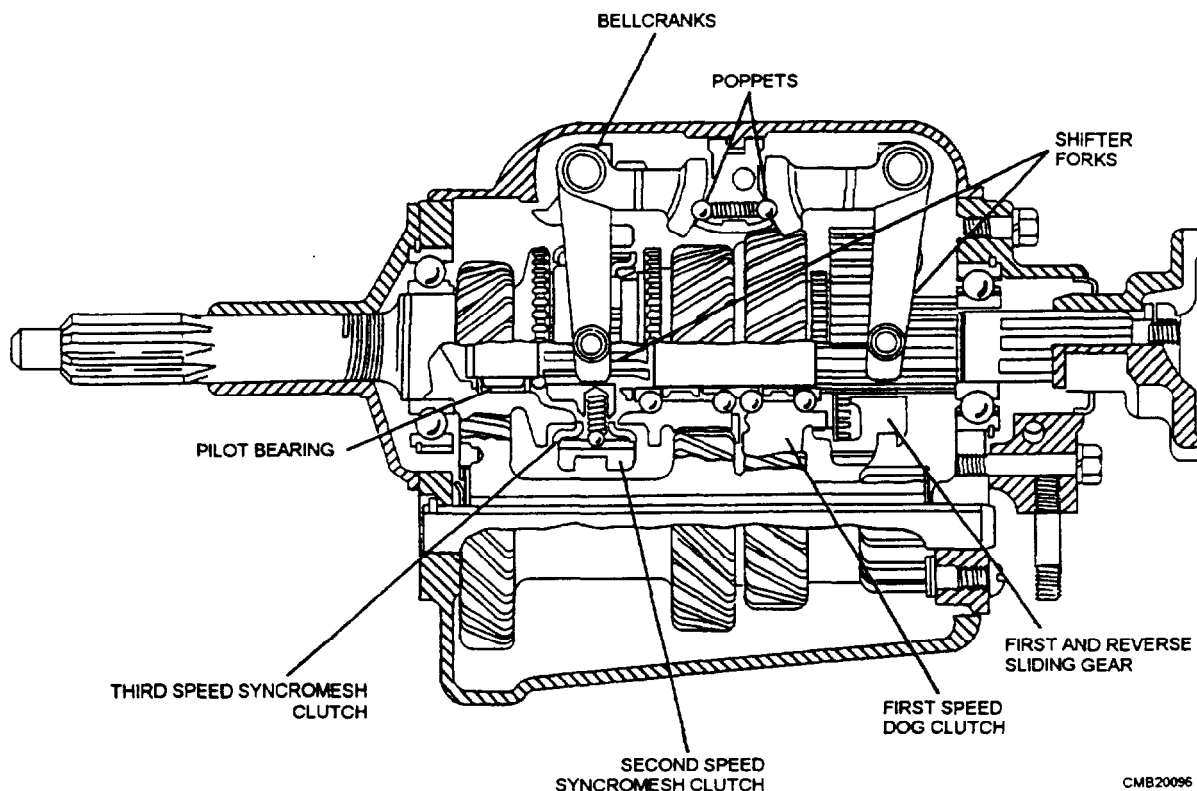

Figure 4-19.—Synchromesh transmission.

CMB20096

## First Gear

To get the vehicle moving from a standstill, the operator moves the gearshift lever into first. The main shaft first-reverse speed gear is slid into position,

meshing the gear with the countershaft first-speed gear. The countershaft first-speed gear and main shaft first-reverse speed gear transmits power to the main shaft (fig. 4-20, view B). Gear ratio is approximately 7.55 to 1.

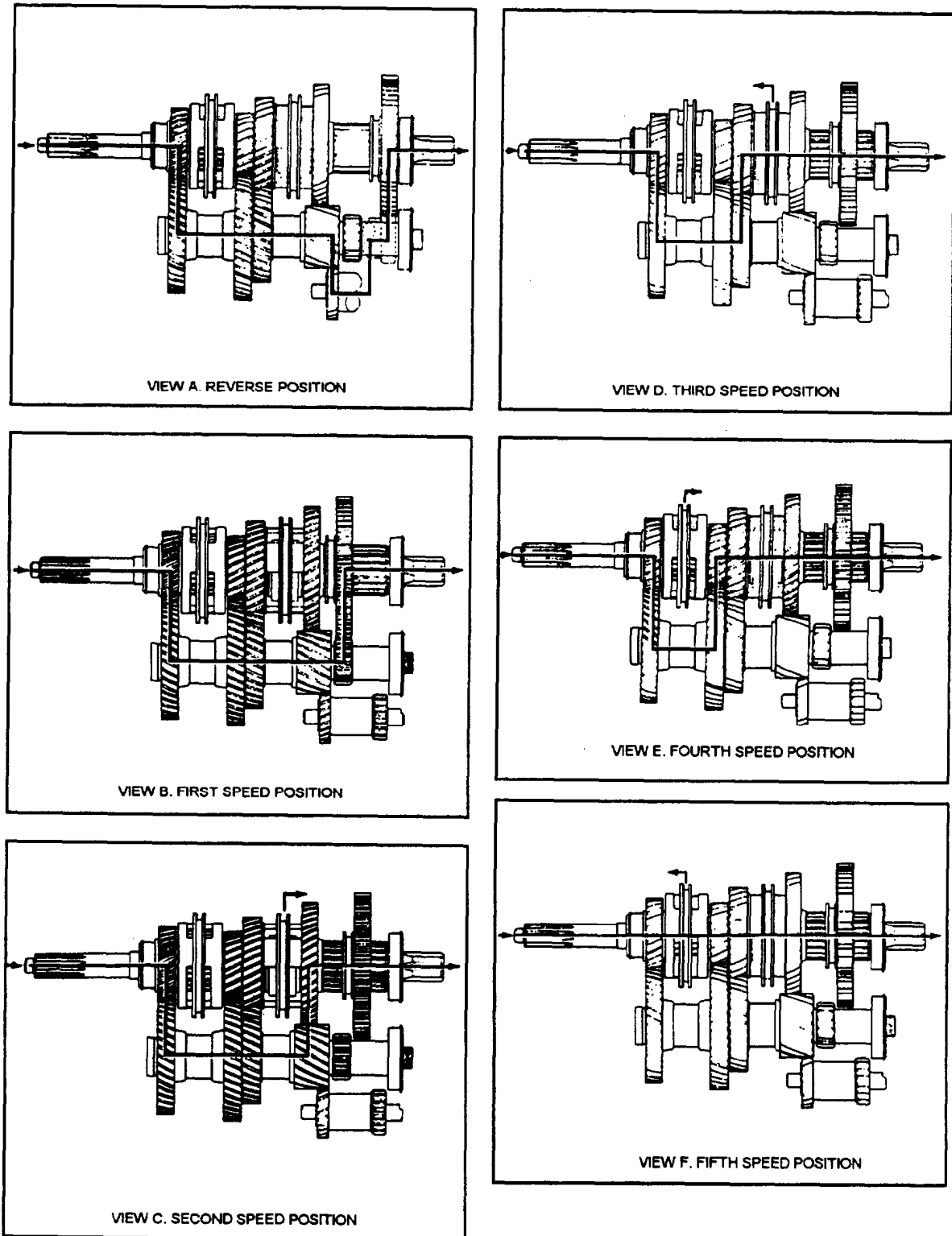

Figure 4-20.—Power flow of a five-speed transmission.

CMB20097

## Second Gear

To shift into second, the operator depresses the clutch and moves the shift lever into second gear. The second-third-speed synchronizer has been moved to the right so its internal teeth engage the external teeth of the main shaft second-speed gear. Power is transmitted by the countershaft second-speed gear to the main shaft second-speed gear, which is coupled to the main shaft by the second-third-gear synchronizer, and to the main shaft (fig. 4-20, view C). Gear ratio is approximately 4.18 to 1.

## Third Gear

To shift into third, the operator depresses the clutch and moves the shift lever disengaging the second-third synchronizer from the main shaft second-speed gear. The second-third-speed synchronizer has been moved to the left so its internal teeth engage the external teeth of the main shaft third-speed gear. Power is transmitted by the countershaft third-speed gear to the main shaft third-speed gear, which is coupled to the main shaft by the second-third synchronizer and through the main shaft (fig. 4-20, view D). Gear ratio is approximately 2.45 to 1.

## Fourth Gear

The operator depresses the clutch and moves the shift lever disengaging the second-third synchronizer from the main shaft third-speed gear. The fourth-fifth-

speed synchronizer has been moved to the right so its internal teeth engage the external teeth of the main shaft fourth-speed gear. Power is transmitted by the countershaft fourth-speed gear through the main shaft fourth-speed gear, which is coupled to the main shaft by the fourth-fifth-speed synchronizer, and through the main shaft (fig. 4-20, view E). Gear ratio is approximately 1.45 to 1.

## Fifth Gear

The operator depresses the clutch and moves the shift lever disengaging the fourth-fifth-speed synchronizer from the main shaft fourth-speed gear. The fourth-fifth-speed synchronizer is moved to the left so its internal teeth engage the external teeth of the input gear. Power is transmitted by the input gear, which is coupled to the main shaft by the fourth-fifth-speed synchronizer. Since the interlocking action of the synchronizer, in effect, makes one continuous shaft of the input shaft and the main shaft, the drive is direct (fig. 4-20, view F). Gear ratio is 1.00 to 1.

## AUXILIARY TRANSMISSIONS

The auxiliary transmission (fig. 4-21) is used to provide additional gear ratios in the power train. This transmission is installed behind the main transmission and power flows directly to it from the main transmission, when of the integral type, or by a short propeller shaft (jack shaft) and universal joints.

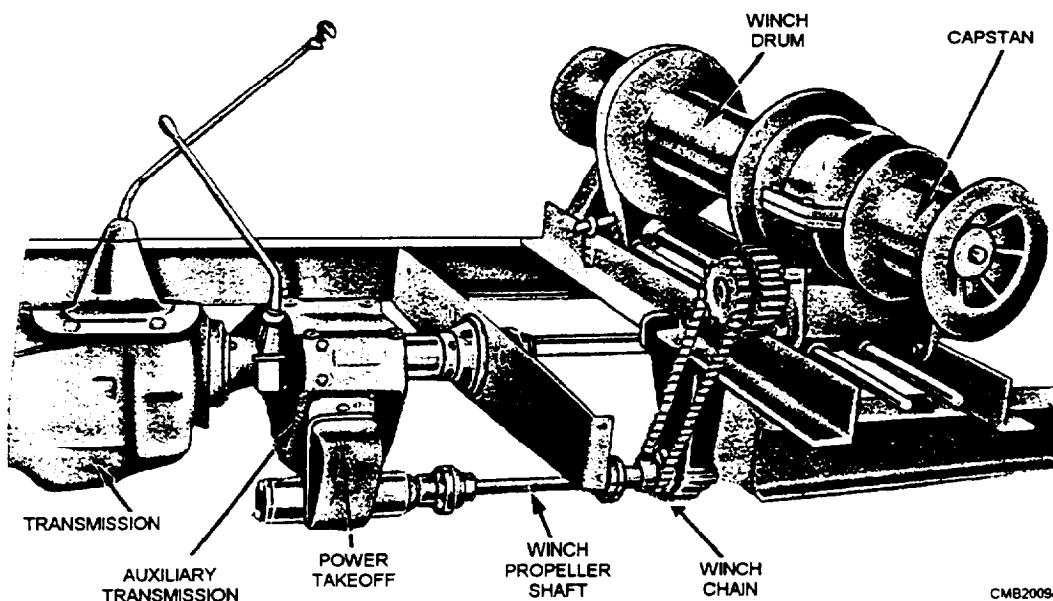

Figure 4-21.—Auxiliary transmission with power takeoff used for driving winch.



Support and alignment are provided by a frame cross member. Rubber-mounting brackets are used to isolate vibration and noise from the chassis. A lever that extends into the operator's compartment accomplishes shifting. Like the main transmission, the auxiliary transmission may have either constant mesh gears or synchronizers to allow for easier shifting.

This transmission, when of the two-speed design, has a low range and direct drive. Three- and four-speed auxiliary transmissions commonly have at least one overdrive gear ratio. The OVERDRIVE position causes increased speed of the output shaft in relation to the input shaft. Overdrive is common on heavy-duty trucks used to carry heavy loads and travel at highway speeds.

The auxiliary transmission shown in figure 4-22 provides two-speed ratios. When it is in the DIRECT DRIVE position, power flows directly through the transmission and is controlled only by the main transmission. When the auxiliary transmission is shifted into LOW RANGE, vehicle speed is reduced and torque is increased. When the low range is used with the lowest speed of the main transmission, the engine drives the wheels very slowly and with less engine horsepower.

In this constant mesh auxiliary transmission, the main gear is part of the input shaft, and it is in constant mesh with the countershaft drive gear. A pilot bearing aligns the main shaft output shaft with the input shaft. The low-speed main shaft gear runs free on the main shaft when direct drive is being used and is in constant mesh with the countershaft low-speed gear. A gear-type dog clutch, splined to the main shaft, slides forward or backward when you shaft the auxiliary transmission into high or low gear position.

In HIGH GEAR, when direct drive from the main transmission is being used, the dog clutch is forward and makes a direct connection between the input shaft and the main shaft. When in LOW GEAR, the dog clutch is meshed with the low-speed, main shaft gear and is disengaged from the main drive gear.

## **TRANSMISSION TROUBLESHOOTING**

Transmissions are designed to last for the life of the vehicle when lubricated and operated properly. The most common cause of failure results from shifting when the vehicle is not completely stopped or without waiting long enough to allow the gears to stop spinning after depressing the clutch pedal. This slight clashing

**Figure 4-22.—Sectional view of an auxiliary transmission showing gear arrangement.**

of gears may not seem significant at the time, but each time this occurs, small particles of the gears will be ground off and carried with the lubricate through the transmission. These small metal particles may become embedded in the soft metal used in synchronizers, reducing the frictional quality of the clutch. At the same time, these particles damage the bearings and their races by causing pitting, rough movement, and noise. Soon transmission failure will result. When this happens, you will have to remove the transmission and replace either damaged parts or the transmission unit.

As a mechanic, the first step toward repairing a transmission is the diagnosis of the problem. To begin diagnosis, gather as much information as possible. Determine in which gears the transmission acts up—first, second, third, fourth, or in all forward gears when shifting. Does it happen at specific speeds? This information will assist you in determining which parts are faulty. Refer to a diagnosis chart in the manufacturer’s service manual when a problem is difficult to locate. It will be written for the exact type of transmission.

### TROUBLESHOOTING A MANUAL TRANSMISSION

<b>Problem</b>	<b>Possible Cause</b>	<b>Corrective Actions</b>
<b>Transmission noise in neutral</b>	Transmission not aligned with engine	Realign
	Bearings dry, badly worn, or broken	Lubricate or replace
	Low oil level	Refill
	Gears worn, scuffed, or broken	Replace
	Countershaft badly worn	Replace
<b>Transmission noisy in gear</b>	Excessive end play of countershaft	Replace
	All causes noted above	Same as above
	Main shaft rear bearing worn or broken	Replace
	Gear teeth worn	Replace
	Engine vibration damper defective	Replace
	Speedometer drive gears worn	Replace
	Clutch disc defective	Replace
	Gears loose on main shaft	Replace worn parts
<b>Hard to shift</b>	Clutch not releasing	Adjust
	Sliding gear tight on shaft splines	Clean splines or replace shaft or gear
	Shift linkage out of adjustment	Adjust
	Main shaft splines distorted	Clean or replace
	Synchronizer damaged	Replace
<b>Gears clash or grind when shifting</b>	Sliding gear teeth damaged	Replace
	Clutch not releasing	Adjust
	Synchronizer defective	Replace
<b>Transmission sticks in gear</b>	Gears sticking on main shaft	Free up gears or replace defective parts
	Clutch not releasing	Adjust
	Detent balls stuck.	Free up the balls
	Shift linkage out of adjustment	Adjust

## TROUBLESHOOTING A MANUAL TRANSMISSION—CONTINUED

Problem	Possible Cause	Corrective Action
<b>Transmission sticks in gear— Continued</b>	Sliding gears tight on shaft splines	Clean splines or replace shaft or gears
<b>Slips out of gear</b>	Shift linkage out of adjustment	Adjust
	Gear loose on shaft	Replace shaft or gear
	Gear teeth worn	Replace
	Excessive end play in gears	Replace
	Lack of spring tension on shift lever detent	Install new spring
	Badly worn transmission bearings	Replace
<b>Transmission leaks oil</b>	Oil level too high	Drain to proper level
	Damaged gaskets	Install new gaskets
	Oil seal damaged or installed improperly	Install new seals
	Oil throw rings damaged, improperly installed, or missing	Install new oil throw rings properly

Many problems that seem to be caused by the transmission are caused by clutch, linkage, or drive line problems. Keep this in mind before removing and disassembling a transmission.

### TRANSMISSION OVERHAUL

Because of the variations in construction of transmissions, always refer to the manufacturer's service manual for proper procedures in the removal, disassembly, repair, assembly, and installation. These operations vary from 6 to 8 hours, depending on transmission type and vehicle manufacturer.

The basic removal procedures are as follows:

1. Unscrew the transmission drain plug and drain the oil.
2. Remove the drive shaft and install a plastic cap over the end of the transmission shaft.
3. Disconnect the transmission linkage at the transmission.
4. Unbolt and remove the speedometer cable from the extension housing.
5. Remove all electrical wires leading to switches on the transmission.
6. Remove any cross members or supports.
7. Support the transmission and engine with jacks. Operate the jack on the engine to take the weight off the transmission. Be careful not to crush the oil pan.

### CAUTION

Never let the engine hang suspended by only the front motor mounts.

8. Depending upon what is recommended by the service manual, either remove the transmission-to-clutch cover bolts or the bolts going into the engine from the clutch cover.
9. Slide the transmission straight back, holding it in alignment with the engine. You may have to wiggle the transmission slightly to free it from the engine.

Once the transmission has been removed from the engine, clean the outside and place it on your workbench. Teardown procedures will vary from one transmission to another. Always consult the service manual for the type of transmission you are working on. If improper disassembly methods are used, major part damage could possibly result.

Before disassembly, remove the inspection cover. This will allow you to observe transmission action. Shift the transmission into each gear, and, at the same time, rotate the input shaft while inspecting the conditions of the gears and synchronizers.

The basic disassembly procedures are as follows:

1. Unbolt and remove the rear extension housing.  
It may be necessary to tap the housing off with a soft face mallet or bronze hammer.
2. Unbolt and remove the front extension housing and any snap rings.
3. Carefully pry the input shaft and gear forward far enough to free the main shaft.
4. Using a brass driftpin, push the reverse idler shaft and countershaft out of the transmission case.
5. Remove the input shaft and output shaft assemblies. Slide the output shaft and gears out of the back of the transmission as a unit. Be careful not to damage any of the gears.

After the transmission is disassembled, clean all the parts thoroughly and individually. Clean all the parts of hardened oil, lacquer deposits, and dirt. Pay particular attention to the small holes in the gears and to the shifter ball bores in the shifter shaft housing. Remove all gasket material using a putty knife or other suitable tool. Ensure that the metal surfaces are not gouged or scratched. Also, clean the transmission bearings and blow-dry them using low-pressure compressed air.

#### **NOTE**

Always use protective eyewear when you are blowing the bearing dry with compressed air. Do NOT allow the bearing to spin. Air pressure can make the bearing spin at tremendously high rpm, possibly causing the bearing to explode and fly apart.

After all parts of the transmission have been cleaned, inspect everything closely to determine whether they can be reused or have to be replaced. The wear or damage to some of the parts will be evident to the eye. If brass-colored particles are found, one or more of the synchronizers or thrust washers are damaged. These are normally the only transmission parts made of this material. If iron chips are found, main drive gears are probably damaged. To check for damage or wear on other parts, it may be necessary to

use measuring tools and gauges to determine their condition.

Any worn or damaged parts in the transmission must be replaced. This is why your inspection is very critical. If any trouble is NOT corrected, the transmission overhaul may fail. You would have to complete the job a second time, wasting man-hours and materials, as well as unnecessary equipment downtime.

Always replace all gaskets and seals in the transmission. Even though the seal or gasket may have not been leaking before disassembly, it may start to leak after assembly.

When replacing a main shaft gear either due to wear or damage, you should also replace the matching gear on the countershaft. If a new gear is meshed with an old gear, transmission gear noise will occur.

If new bolts are needed, make sure it is the correct thread type and length. Some transmission use metric bolts. Remember mixing threads will cause part damage.

All parts must be lightly coated with a medium-grade lubricating oil. This is done immediately after the inspection or repair. Oiling the parts give them a necessary rust-preventive coating and facilitates the assembly process.

After obtaining new parts to replace the worn or damaged parts, you are ready for transmission assembly. To assemble the transmission, use the reverse order of disassembly. Again refer to the service manual for exact directions, as well as proper clearances and wear limits of the parts. The service manual will have an exploded view of the transmission. It will show how each part is located in relation to the others. Step-by-step direction will accompany the illustrations.

Certain key areas of the transmission should be given extra attention during assembly. One area is the needle bearings. To hold the needle bearings into the countershaft or other shafts, you coat the bearings with HEAVY GREASE. The grease will hold the bearing in place as you slide the countershaft into the gears. Also, measure the end play or clearance of the gears and synchronizers and the countershaft and case as directed by the service manual.

Before installing, ensure the transmission shifts properly. This will save you from having to remove the transmission if there is still problems. Also, since the transmission is already out, this is an ideal time to inspect the condition of the clutch.

Before installation, place a small amount of grease in the pilot bearing and on the release bearing inner surface. Now, the transmission is ready to be installed. Basic transmission installation is as follows:

### NOTE

DO NOT place any lubricant on the end of the clutch shaft input splines or pressure plate release levers. Grease in these locations can spray onto the clutch disc, causing clutch slippage and failure.

1. Place the transmission on the transmissionjack.
2. Position the transmission behind the engine. Ensure that the release bearing is in place on the clutch fork.
3. Carefully align the transmission and engine, ensuring that the input and output shaft lines up perfectly with the center line of the engine crankshaft. If the transmission is slightly tilted, it will not fit into place.
4. With the transmission in high gear, slowly push the transmission into the clutch housing. You may need to raise or lower the transmission slightly to keep it aligned.
5. When the transmission is almost in place, wiggle the extension housing in a circular motion while pushing toward the engine. This will help start the input shaft in the pilot bearing. The transmission will then slide into position.
6. With the transmission bolted to the clutch cover, install the rear support or cross member and transmission mount. Reinstall the clutch linkage, the transmission linkage, and any other parts.
7. Adjust the clutch.

With the transmission installed and the clutch adjusted, test-drive the vehicle for proper operation. If the transmission is noisy, extremely loose, or binds, it must be removed and disassembled for further inspection and corrective action.

### TRANSMISSION SERVICE

The manual transmission should have the oil level checked at each PM. Recurrent low oil level indicates that there is leakage around the oil seals.

If you notice foaming in the oil, drain the transmission and refill it with clean oil. Foaming is evidence that water or some other lubricant that will not mix with the recommended transmission oil is present.

When it becomes necessary to change the transmission oil, the following procedure should be used:

1. Before you drain the oil, clean around the drain and fill plugs thoroughly. Both drain and fill plugs should be removed to allow the oil to drain.
2. Drain the transmission immediately after the vehicle has been operated. The oil will then be warm and will readily drain, taking along the suspended contaminants as it drains.
3. Check the drained oil for any uncommon foreign matter, such as large metal particles (steel or brass). This is a good sign of internal damage to the gears, bearings, or synchronizers. If large particles are found, notify your shop supervisor for further instructions.
4. Once the transmission has drained completely and no large metal particles are found, you replace the drain plug and refill the transmission with the proper grade of oil until it reaches the bottom of the fill plug. You then replace the fill plug.

Other than the periodic check required on the transmission fluid, drain and refill are performed as prescribed by the manufacturer. You should check the bolts for tightness and inspect the case for damage each scheduled PM.

### REVIEW 2 QUESTIONS

- Q1. What material is most commonly used in casting a transmission case?*
- Q2. What four shafts are located in a manual transmission?*
- Q3. What are the two functions of the synchronizer?*
- Q4. What are the two types of shift linkages used on manual transmissions?*
- Q5. What type of equipment uses a sliding gear transmission?*
- Q6. If first gear ratio is 7.55 to 1, what is the gear ratio when the transmission is shifted into reverse?*

## AUTOMATIC TRANSMISSIONS

**Learning Objective:** State the operating principles, identify the components, and maintenance procedures of an automatic transmission.

The automatic transmission (fig. 4-23), like the manual transmission, is designed to match the load requirements of the vehicle to the power and speed range of the engine. The automatic transmission, however, does this automatically depending on throttle position, vehicle speed, and the position of the control lever. Automatic transmissions are built in models that have two-, three-, or four-forward speeds and in some that are equipped with overdrive. Operator control is limited to the selection of the gear range by moving a control lever.

The automatic transmission is coupled to the engine through a torque converter. The torque converter is used with an automatic transmission, because it does not have to be manually disengaged by the operator each time the vehicle is stopped. Because the automatic transmission shifts without any interruption of engine torque application, the cushioning

effect of the fluid coupling within the torque converter is desirable.

Because the automatic transmission shifts gear ratios independent of the operator, it must do so without the operator releasing the throttle. The automatic transmission does this by using planetary gearsets whose elements are locked and released in various combinations that produce the required forward and reverse gear ratios. The locking of the planetary gearset elements is done through the use of hydraulically actuated multiple-disc clutches and brake bands. The valve body controls the hydraulic pressure that actuates these locking devices. The valve body can be thought of as a hydraulic computer that receives signals that indicate vehicle speed, throttle position, and gearset lever position. Based on this information, the valve body sends hydraulic pressure to the correct locking devices.

The parts of the automatic transmission are as follows:

- Torque converter—fluid coupling that connects and disconnects the engine and transmission.

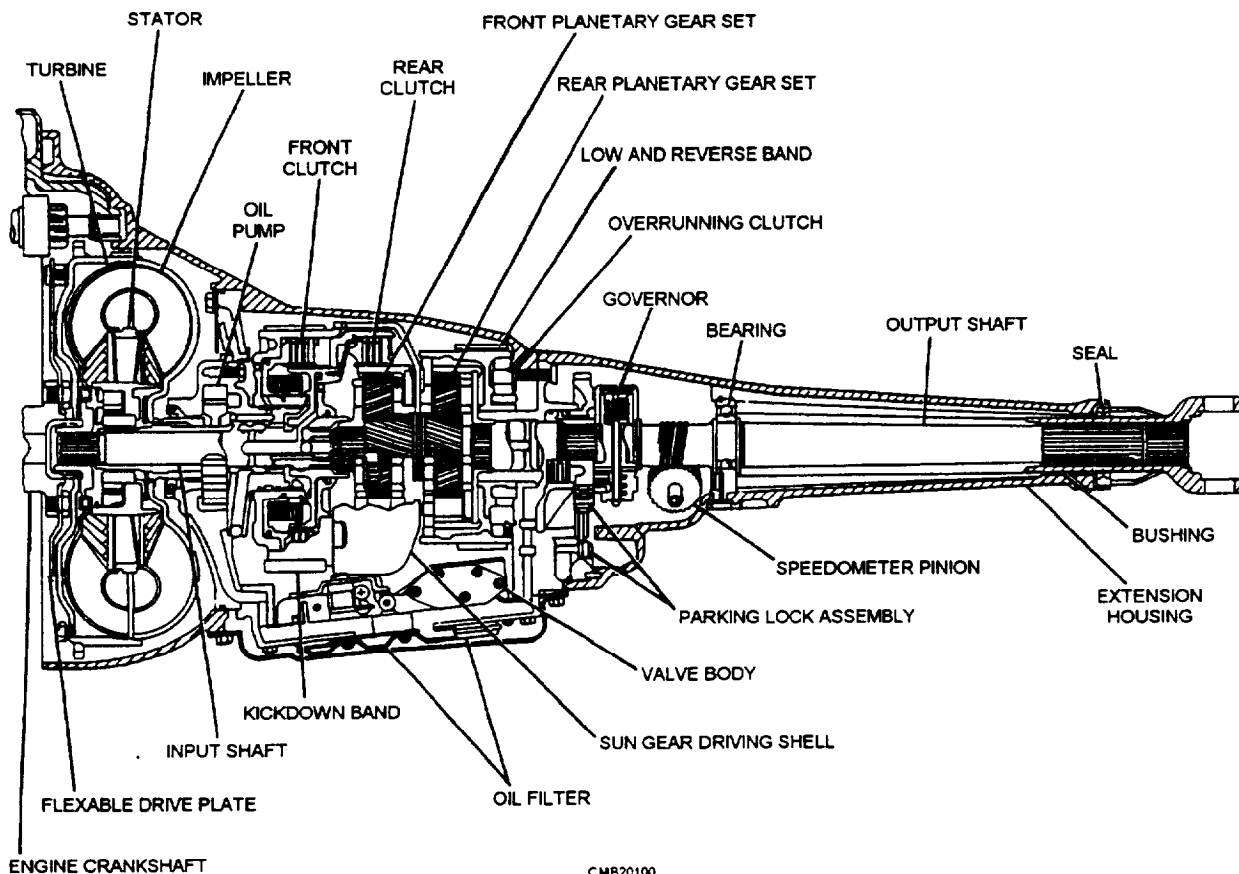

Figure 4-23.—Automatic transmission cross-sectional view.

- Input shaft—transfers power from the torque converter to internal drive members and gearsets.
- Oil pump—produces pressure to operate hydraulic components in the transmission.
- Valve body—operated by shift lever and sensors; controls oil flow to pistons and servos.
- Pistons and servos—actuates the bands and clutches.
- Bands and clutches—applies clamping or driving pressure on different parts of gearsets to operate them.
- Planetary gears—provides different gear ratios and reverse gear.
- Output shaft—transfers engine torque from the gearsets to the drive shaft and rear wheels.

## TORQUE CONVERTERS

The torque converter is a fluid clutch that performs the same basic function as a manual transmission dry friction clutch (fig. 4-24). It provides a means of uncoupling the engine for stopping the vehicle in gear. It also provides a means of coupling the engine for acceleration.

A torque converter has four basic parts:

1. Outer housing—normally made of two pieces of steel welded together in a doughnut shape, housing the impeller, stator, and turbine. The housing is filled with transmission fluid.
2. Impeller—driving member that produces oil movement inside the converter whenever the engine is running. The impeller is also called the converter pump.
3. Turbine—a driven fan splined to the input shaft of the automatic transmission. Placed in front of

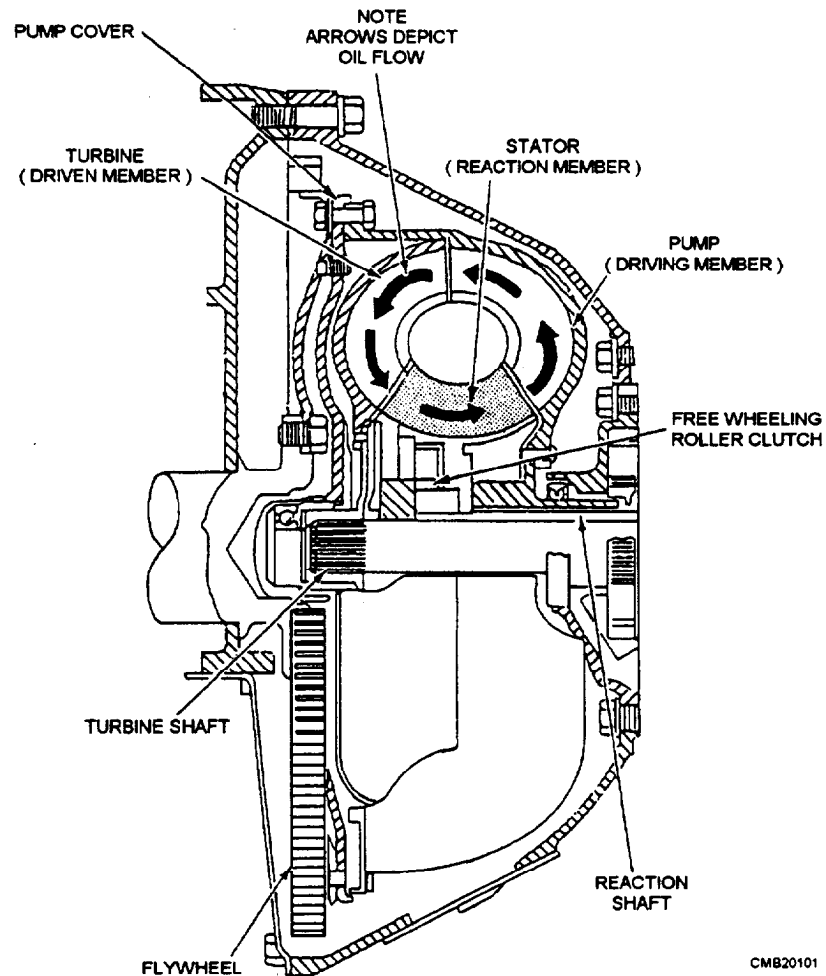

Figure 4-24.—Torque converter, partial cutaway view.

the stator and impeller in the housing. The turbine is not fastened to the impeller but is free to turn independently. Oil is the only connection between the two.

4. Stator—designed to improve oil circulation inside the torque converter. Increases efficiency and torque by causing the oil to swirl around the inside of the housing.

The primary action of the torque converter results from the action of the impeller passing oil at an angle into the blades of the turbine. The oil pushes against the faces of the turbine vanes, causing the turbine to rotate in the same direction as the impeller (fig. 4-25). With the engine idling, the impeller spins slowly. Only a small amount of oil is thrown into the stator and turbine. Not enough force is developed inside the torque converter to spin the turbine. The vehicle remains stationary with the transmission in gear.

During acceleration, the engine crankshaft, the converter housing, and the impeller begin to move faster. More oil is thrown out by centrifugal force, turning the turbine. As a result, the transmission input shaft and vehicle starts to move, but with some slippage.

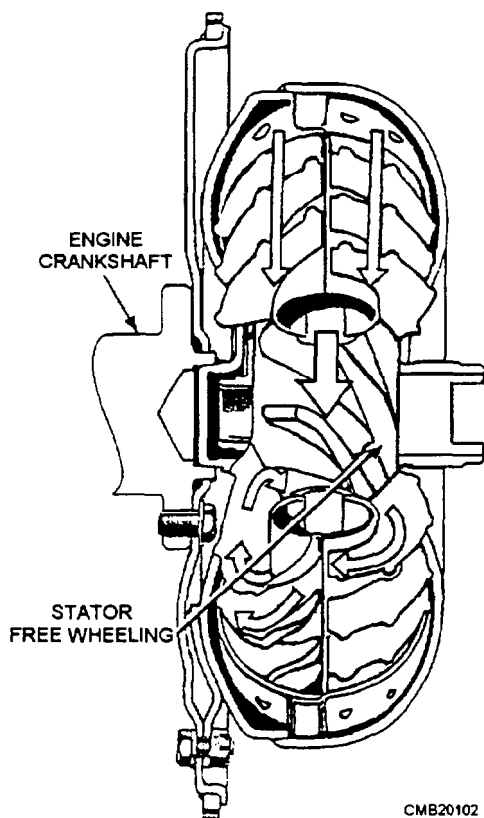

Figure 4-25.—Torque converter in fluid coupling stage.

At cruising speeds, the impeller and turbine spin at almost the same speed with very little slippage. When the impeller is spun fast enough, centrifugal force throws oil out hard enough to almost lock the impeller and turbine. After the oil has imparted its force to the turbine, the oil follows the contour of the turbine shell and blades so that it leaves the center section of the turbine spinning counterclockwise.

Because the turbine has absorbed the force required to reverse the direction of the clockwise spinning of the oil, it now has greater force than is being delivered by the engine. The process of multiplying engine torque has begun,

Torque multiplication refers to the ability of a torque converter to increase the amount of engine torque applied to the transmission input shaft. Torque multiplication occurs when the impeller is spinning faster than the turbine (fig. 4-26). For example, if the engine is accelerated quickly, the engine and impeller rpm might increase rapidly while the turbine is almost stationary. This is known as stall speed. Stall speed of a torque converter occurs when the impeller is at maximum speed without rotation of the turbine. This condition causes the transmission fluid to be thrown

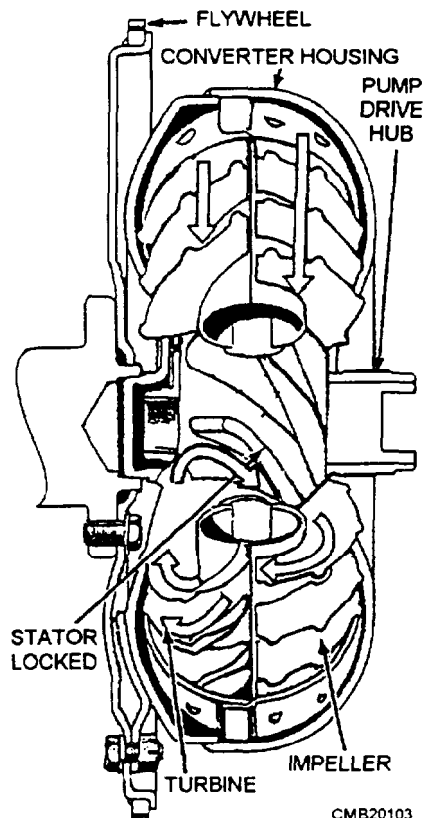

Figure 4-26.—Torque converter in torque multiplication



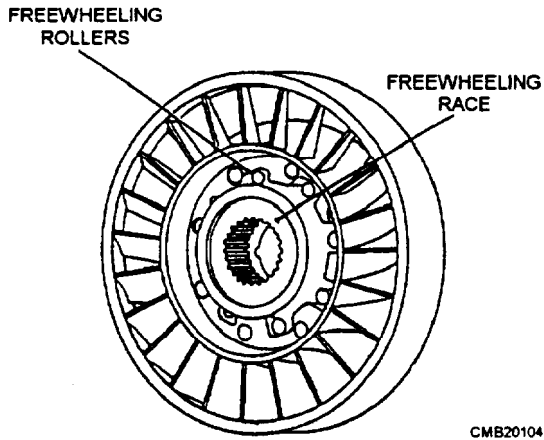

Figure 4-27.—Stator assembly.

off the stator vanes at tremendous speeds. The greatest torque multiplication occurs at stall speed.

When the turbine speed nears impeller speed, torque multiplication drops off. Torque is increased in the converter by sacrificing motion. The turbine spins slower than the impeller during torque multiplication.

If the counterclockwise oil were allowed to continue to the center section of the impeller, the oil would strike the blades of the pump in a direction that would hinder its rotation and cancel any gains in torque. To prevent this, you can add a stator assembly.

The stator (fig. 4-27) is located between the pump and the turbine and is mounted on a one-way clutch

that allows it to rotate clockwise but not counterclockwise. The purpose of the stator is to redirect the oil returning from the turbine and change its rotation back to that of the impeller. Stator action is only needed when the impeller and turbine are turning at different speeds. The one-way clutch locks the stator when the impeller is turning faster than the turbine. This causes the stator to route oil flow over the impeller vanes properly. Then, when turbine speed almost equals impeller speed, the stator can freewheel on its shaft so not to obstruct flow.

Even at normal highway speeds, there is a certain amount of slippage in the torque converter. Another type of torque converter that is common on modern vehicles is the lockup torque converter (fig. 4-28). The lockup torque converter provides increased fuel economy and increased transmission life through the elimination of heat caused by torque converter slippage. A typical lockup mechanism consists of a hydraulic piston, torsion springs, and clutch friction material.

In lower gears, the converter clutch is released. The torque converter operates normally, allowing slippage and torque multiplication. However, when shifted into high or direct drive, transmission fluid is channeled to the converter piston. The converter piston pushes the friction discs together, locking the turbine and impeller. The crankshaft is able to drive the transmission input shaft directly, without slippage. The torsion springs assist to dampen engine power pulses entering the drive train.

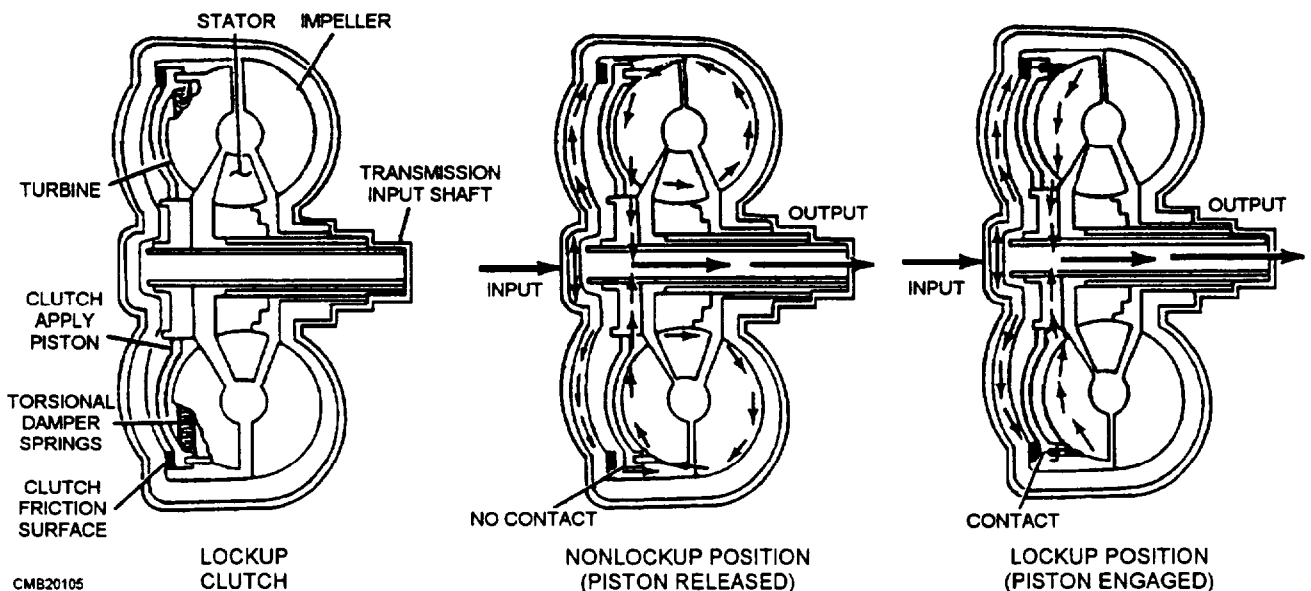

Figure 4-28.—Torque converter with lockup clutch.

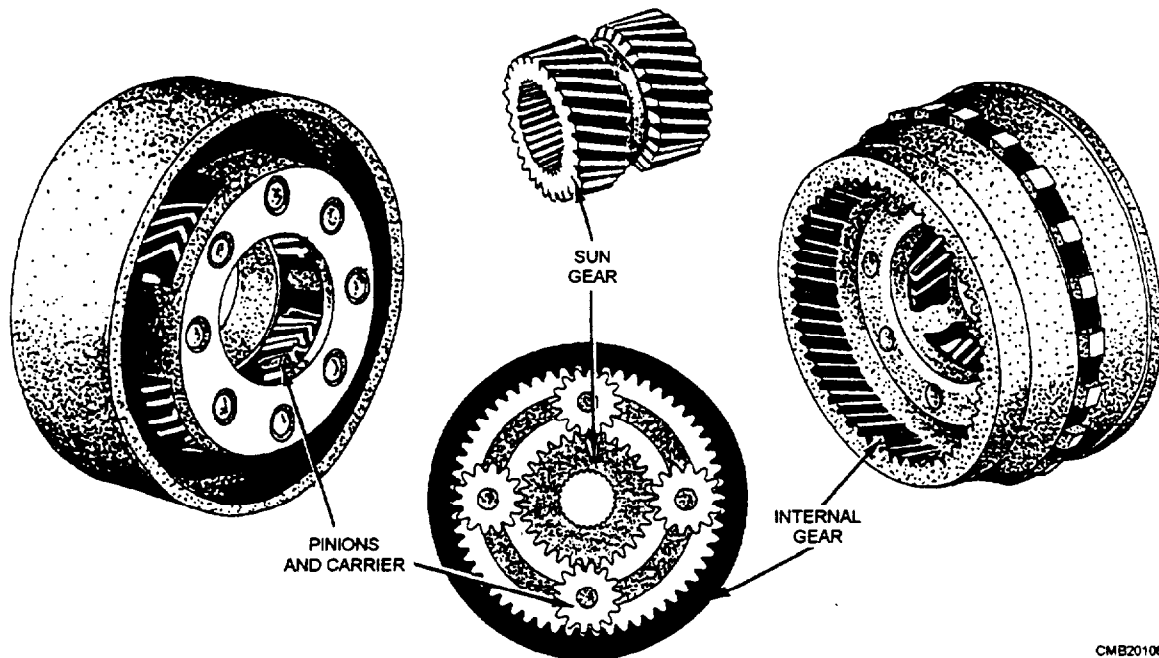

Figure 4-29.—Planetary gearset.

## PLANETARY GEARSETS

A planetary gearset (fig. 4-29) consists of three members—sun gear, ring gear, and planetary carrier which holds the planetary gears in proper relation with the sun and ring gear. The planetary gears are free to rotate on their own axis while they "walk" around the sun gear or inside the ring gear.

By holding or releasing the components of a planetary gearset, it is possible to do the following:

- Reduce output speed and increase torque (gear reduction).
- Increase output speed while reducing torque (overdrive).
- Reverse output direction (reverse gear).
- Serve as a solid unit to transfer power (one to one ratio).
- Freewheel to stop power flow (park or neutral).

Figure 4-30 shows the simplest application of planetary gears in a transmission. With the application shown, two forward speeds and neutral are possible. High gear or direct drive is shown. The clutch is holding the planet carrier to the input shaft, causing the carrier and sun gear to rotate as a single unit. With the clutch released, all gears are free to rotate and no power is transmitted to the output shaft. In neutral, the planetary carrier remains stationary while the pinion

gears rotate on their axis and turn the ring gear. Should the brake be engaged on the ring gear, the sun gear causes the planetary gears to walk around the inside of the ring gear and force the planet carrier to rotate in the same direction as the sun gear, but at a slower speed (low gear). To provide additional speed ranges or a reverse, you must add other planetary gearsets to this transmission.

A compound planetary gearset combines two planetary units into one housing or ring gear. It may have two sun gears or a long sun gear to operate two

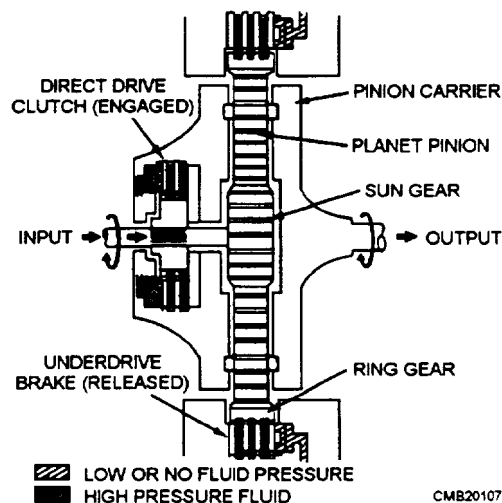

Figure 4-30.—Simple planetary gear application.

sets of planetary gears. A compound planetary gearset is used to provide more forward gear ratios than a simple planetary gearset.

## CLUTCHES AND BANDS

Automatic transmission clutches and bands are friction devices that drive or lock planetary gearsets members. They are used to cause the gearset to transfer power.

### Multiple-Disc Clutch

The **multiple-disc clutch** is used to transmit torque by locking elements of the planetary gearsets to rotating members within the transmission. In some cases, the multiple-disc clutch is also used to lock a planetary gearset element to the transmission case so it can act as a reactionary member. The multiple-disc

clutch is made up of the following components (fig. 4-31).

**DISCS AND PLATES.**—The active components of the multiple-disc clutch are the discs and the plates. The discs are made of steel and are faced with a friction material. They have teeth cut into their inner circumference to key them positively to the clutch hub. The plates are made of steel with no lining. They have teeth cut into their outer circumference to key them positively with the inside of a clutch drum or to the inside of the transmission case. By alternately stacking the discs and plates, they are locked together or released by simply squeezing them.

**CLUTCH DRUM AND HUB.**—The clutch drum holds the stack of discs and plates and is attached to the planetary gearset element that is being driven. The clutch hub attaches to the driving member and fits inside the clutch discs and plates.

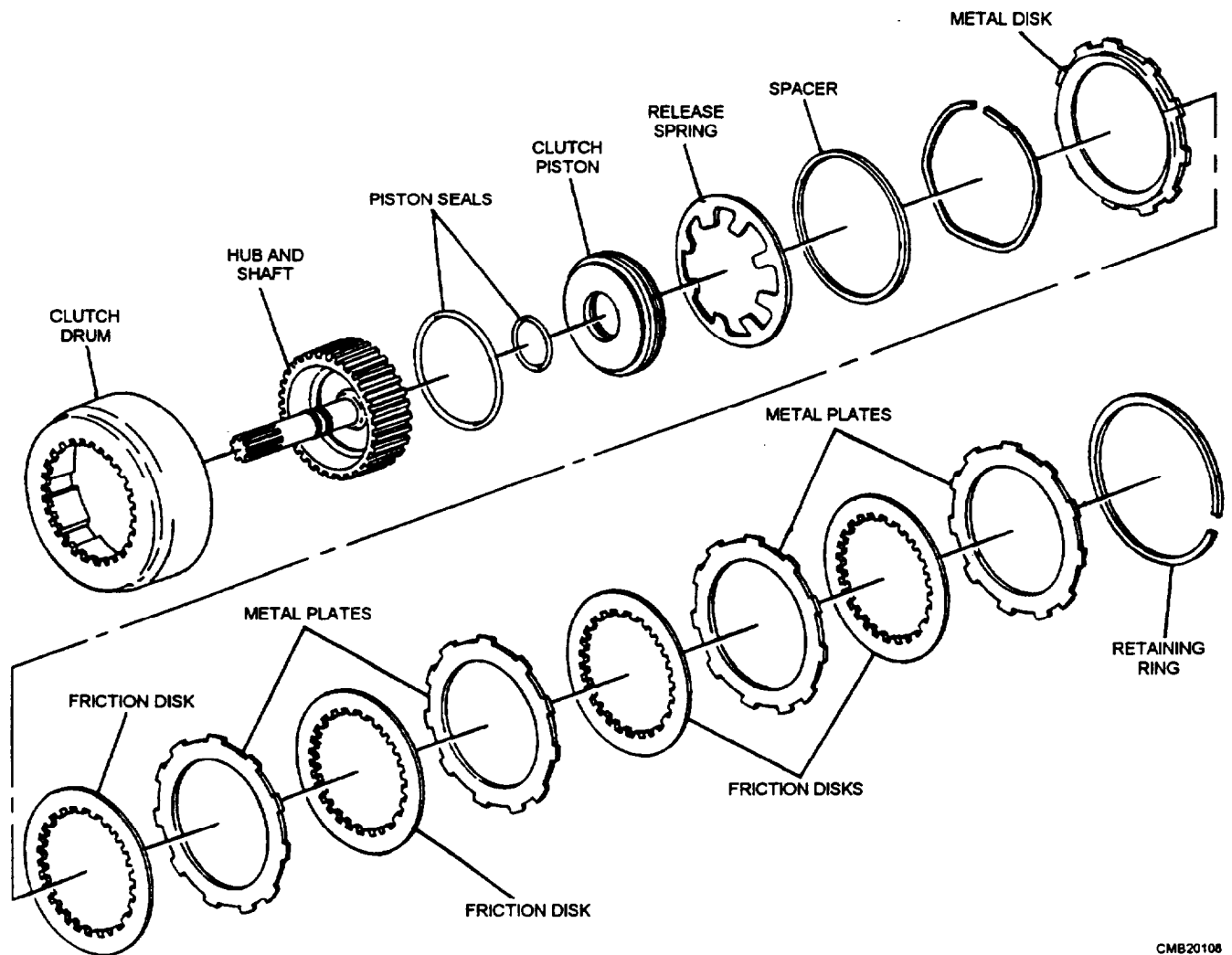

CMB20108

Figure 4-31.—Multiple-disc clutch.

**PRESSURE PLATE.**—The pressure plates are thick clutch plates that are placed on either end of the stack. Their purpose is to distribute the application pressure equally on the surfaces of the clutch discs and plates.

**CLUTCH PISTON.**—The clutch piston uses hydraulic pressure to apply the clutch. Hydraulic pressure is supplied to the clutch piston through the center of the rotating member.

**CLUTCH PISTON SEALS.**—The clutch piston seals serve to prevent the leakage of hydraulic pressure around the inner and outer circumferences of the clutch piston.

**CLUTCH SPRINGS.**—The clutch springs ensure rapid release of the clutch when hydraulic pressure to the clutch piston is released. The clutch springs may be in the form of several coil springs equally spaced around the piston or one large coil spring that fits in the center of the clutch drum. Some models use a diaphragm-type clutch spring.

The operation of the multiple-disc clutch is as follows (fig. 4-32):

**RELEASED**—When the clutch is released, there is no hydraulic pressure on the clutch piston and the

clutch discs and plates are free to rotate within each other. The result is that the clutch hub rotates freely and does not drive the clutch drum.

**APPLIED**—When the clutch is applied, hydraulic pressure is applied to the clutch piston that, in turn, applies pressure to the clutch discs and plates, causing them to lock together. The result is that the clutch hub drives the clutch drum through the clutch.

### Overrunning Clutch

An **overrunning clutch** is used in automatic transmissions to lock a planetary gearset to the transmission case so that it can act as a reactionary member. The overrunning clutch for the planetary gears is similar to the one in a torque converter stator or an electric starting motor drive gear. A planetary gearset overrunning clutch consists of an inner race, set of springs, rollers, and an outer race.

Operation of the overrunning clutch is very simple to understand. When driven in one direction, rollers lock between ramps on the inner and outer race, allowing both races to turn. This action can be used to stop movement of the planetary member, for example. When turned in the other direction, rollers walk off the ramps, and the races are free to turn independently.

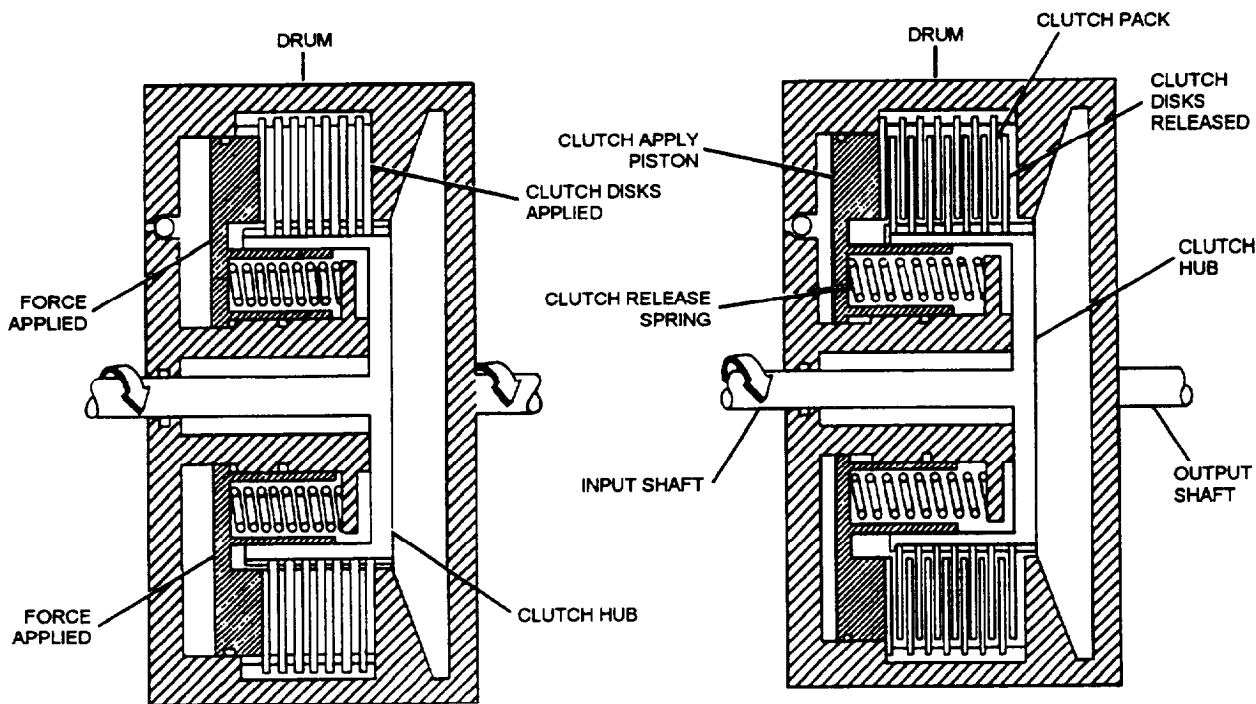

CMB20109

Figure 4-32.—Multiple-disc clutch operation.

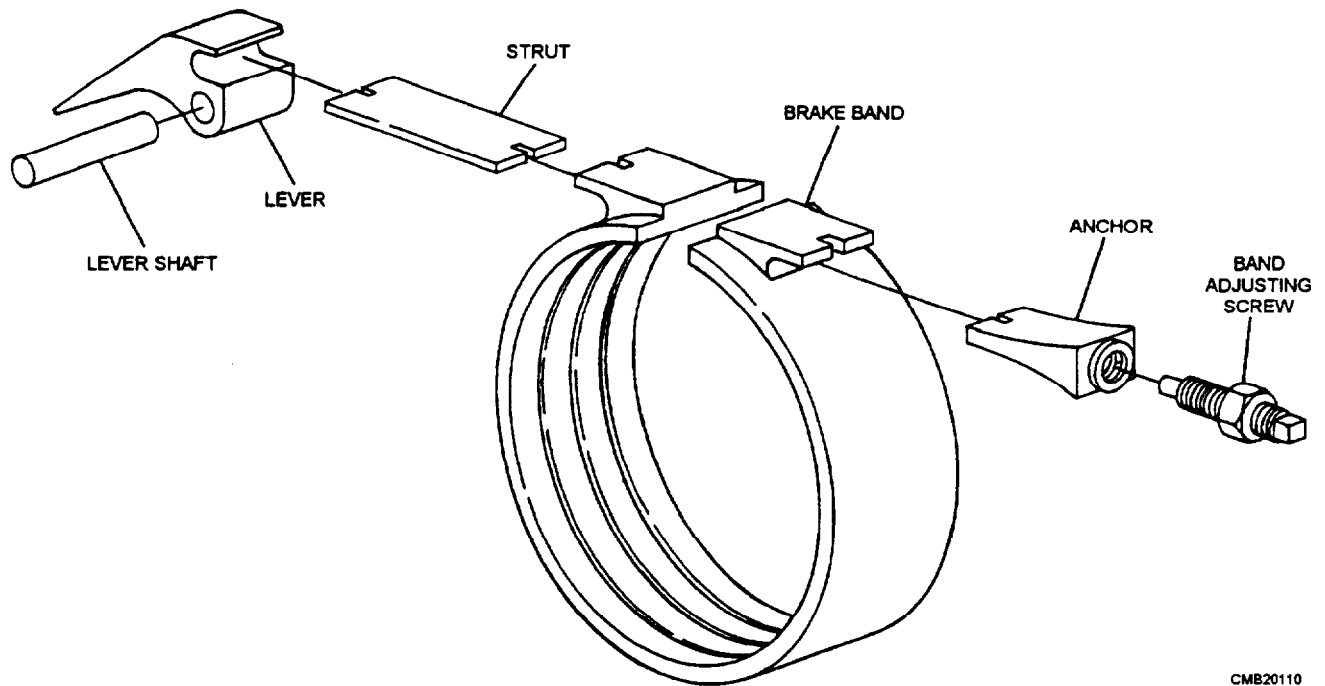

CMB20110

Figure 4-33.—Brake band.

## Brake Band

The brake band is used to lock a planetary gearset element to the transmission case so that the element can act as a reactionary member. The brake band is made up of the following elements (fig. 4-33):

**BAND.**—The brake band is a circular piece of spring steel that is rectangular in cross section. Its inside circumference is lined with a friction material. The brake band has bosses on each end so that it can be held and compressed.

**DRUM.**—The drum fits inside of the band and attaches to the planetary gear-set element and is to be locked by the band. Its outer surface is machined smoothly to interact with the friction surface of the brake band. By pulling the open ends of the band together, the rotation of the drum stops.

**ANCHOR.**—The anchor firmly attaches one end of the brake band to the transmission case. A provision for adjusting the clearance between the band and the drum is usually provided on the anchor.

**SERVO.**—The servo uses hydraulic pressure to squeeze the band around the drum. The servo piston is acted on by hydraulic pressure from the valve body that is fed through an internal passage through the case. The servo piston has a seal around it to prevent leakage of hydraulic pressure and is spring loaded to allow quick

release of the band. Some servos use hydraulic pressure on both sides of their pistons so that they use hydraulic pressure for both the release and the application of the band.

The operation of the brake band is as follows (fig. 4-34):

- Released—When the brake band is released, there is no hydraulic pressure applied to the servo, and the drum is free to rotate within the band.
- Applied—When the brake band is applied, hydraulic pressure is applied to the servo that, in turn, tightens the band around the drum. The result is that the drum is locked in a stationary position, causing an output change from the planetary gearset.

In the applied circuit of a clutch or band, an accumulator is used to cushion initial application (fig. 4-35). It temporarily absorbs some of the hydraulic pressure to cause slower movement of the applied piston.

## HYDRAULIC SYSTEM

The hydraulic system of an automatic transmission serves four basic purposes:

1. Actuates clutches and brake bands by hydraulic pressure from the hydraulic slave circuits.

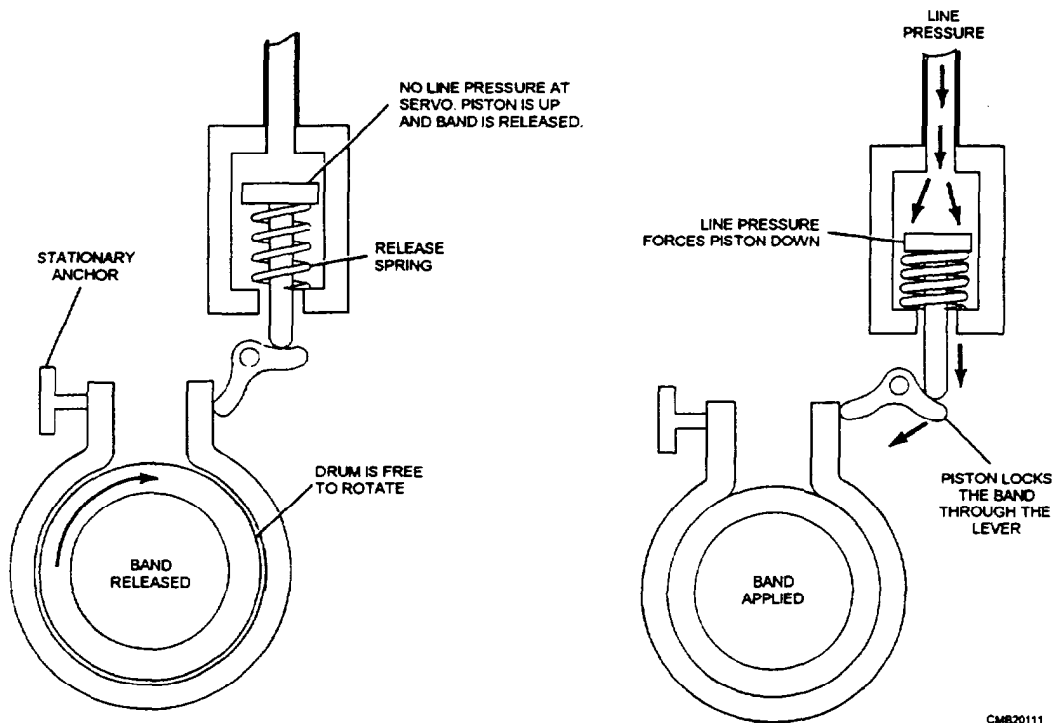

CMB20111

Figure 4-34.—Brake band operation.

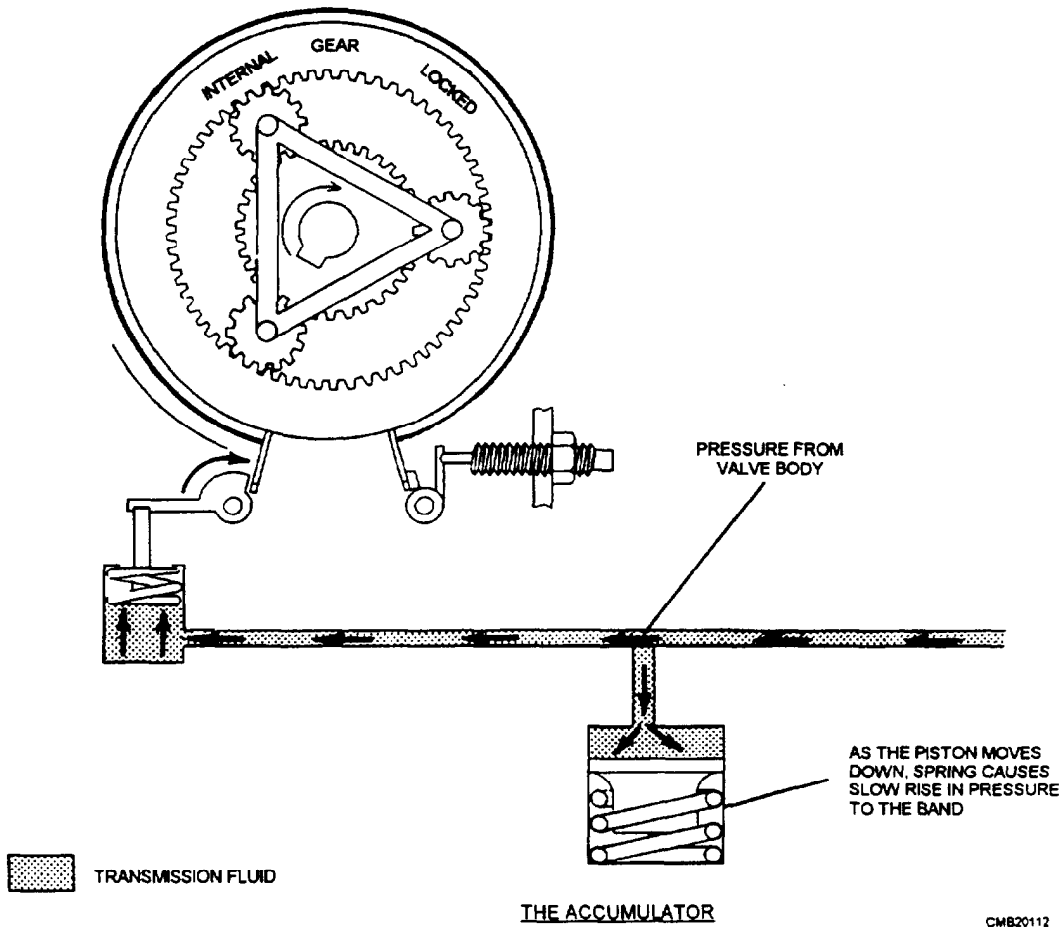

CMB20112

Figure 4-35.—Operation of the accumulator.

2. Controls the shifting pattern of the transmission. This is done by switching hydraulic pressure to programmed combinations of clutches and brake bands based on vehicle speed and engine load.
3. Circulates the transmission fluid through a remote cooler to remove excess heat that is generated in the transmission and torque converter.
4. Provides a constant fresh supply of oil to all critical wearing surfaces of the transmission.

The hydraulic system for an automatic transmission typically consists of the following.

### Pump

The typical hydraulic pump (fig. 4-36) is an internal-external rotor or gear-type pump. Located in the front of the transmission case, it is keyed to the torque converter hub so that it is driven by the engine. As the torque converter spins the oil pump,

transmission fluid is drawn into the pump from the transmission pan. The pump compresses the oil and forces it to the pressure regulator. The pump has several basic functions:

- Produces pressure to operate the clutches, the bands, and the gears.
- Lubricates the moving parts in the transmission.
- Keeps the torque converter filled with transmission fluid for proper operation.
- Circulates transmission fluid through the transmission and cooling tank (radiator) to transfer heat.
- Operates hydraulic valves in the transmission.

### Pressure Regulator

The pressure regulator limits the maximum amount of oil pressure developed by the oil pump. It is a spring-loaded valve that routes excess pump pressure out of the hydraulic system, assuring proper transmission operation.

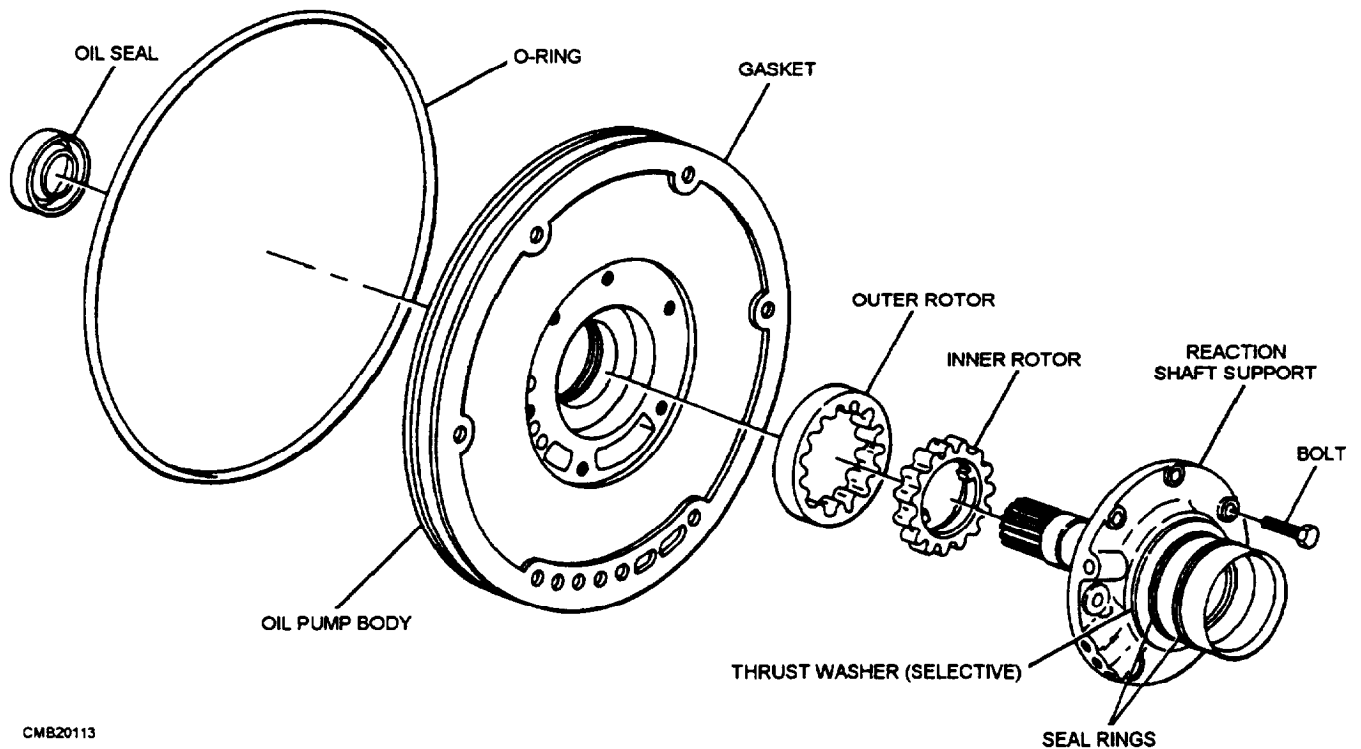

CMB20113

Figure 4-36.—Typical transmission hydraulic pump.

## Manual Valve

A manual valve (fig. 4-37), operated by the shift mechanism, allows the operator to select park, neutral, reverse, or different drive ranges. A manual valve is basically a multiport spool valve that switches line pressure to selected passages, as it is moved through its operating positions.

## Vacuum Modulator Valve

The vacuum modulator valve (fig. 4-38) is a diaphragm device that uses engine manifold vacuum to indicate engine load to the shift valve. As engine vacuum (load) rises and falls, it moves the diaphragm inside the modulator. This, in turn, moves the rod and hydraulic valve to change throttle control pressure in

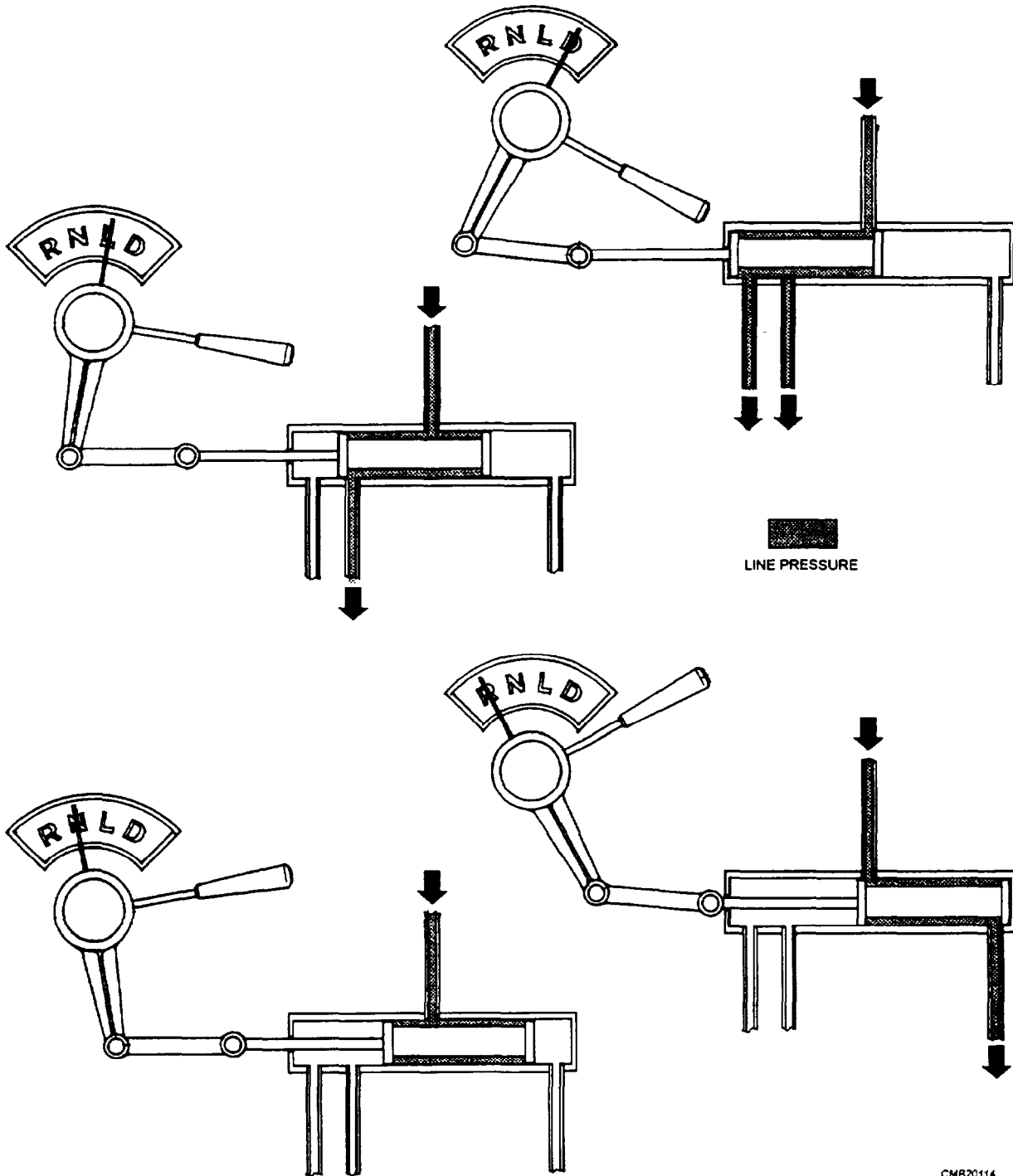
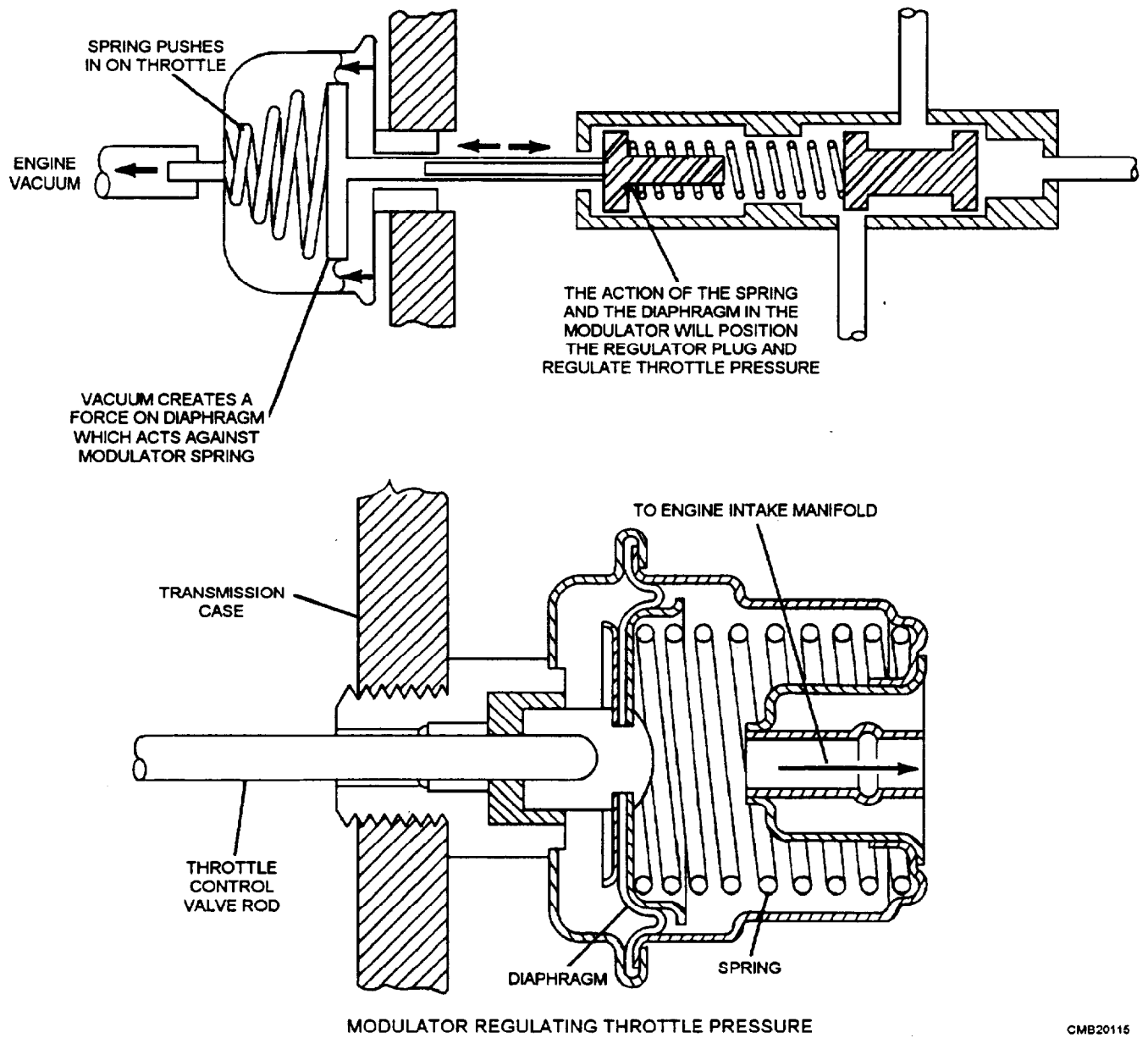

Figure 4-37.—Manual valve operation.

CMB20114





CMB20115

Figure 4-38.—Vacuum modulator valve.

the transmission. In this way, the vacuum modulator can match transmission shift points to engine loads.

### Governor Valve

The governor valve (fig. 4-39) senses engine speed (transmission output shaft speed) to help control gear shifting. The vacuum modulator and governor work together to determine shift points. The governor gear is

meshed with a gear on the transmission output shaft. Whenever the vehicle and output shaft are moving, the centrifugal weights rotate. When the output shaft and weights are spinning slowly, the weights are held in by the governor springs, causing low-pressure output and the transmission remains in low gear. As the engine speeds increases, the weights are thrown out further and governor pressure increases, moving the shift valve and causing the transmission to shift into higher gear.

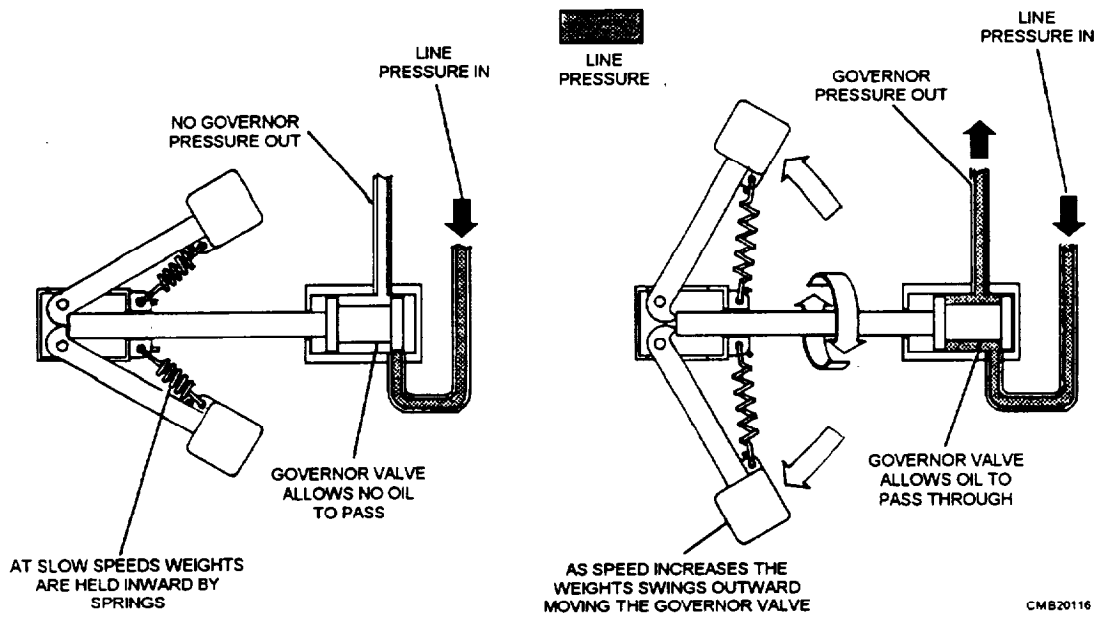

Figure 4-39.—Operation of the governor.

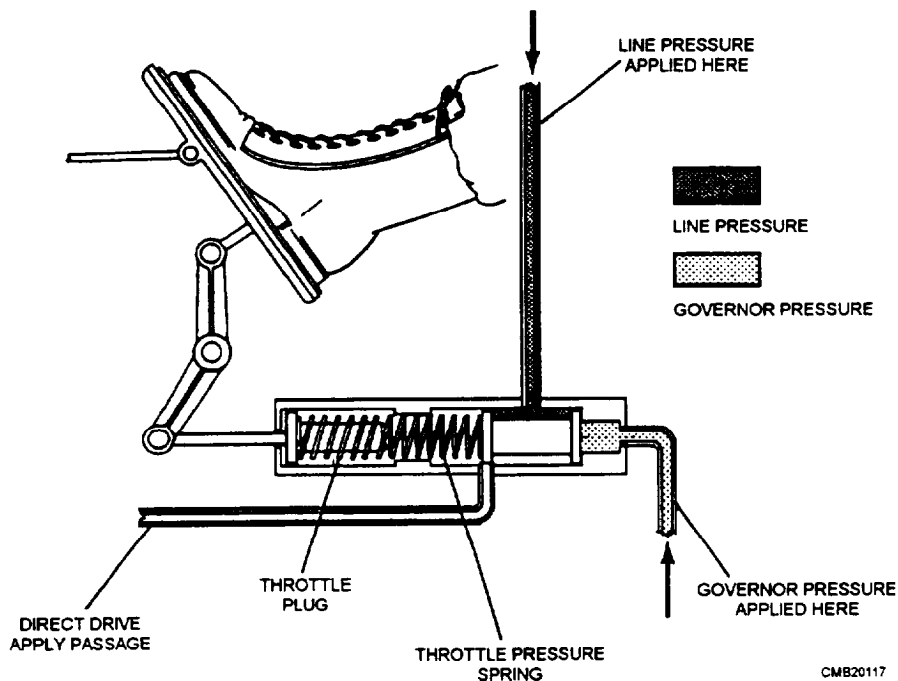

Figure 4-40.—Shift valve.

## Shift Valves

The shift valves (fig. 4-40) are simple balance-type spool valves that select between low and high gear when the manual valve is in drive. Using control pressure (oil pressure from the regulator, governor, vacuum modulator, and manual valves), they operate the bands, servos, and gearsets. Oil pressure from the other transmission valves acts on each end of the shift valve. In this way, the shift valve is sensitive to engine load (vacuum modulator valve oil pressure), engine speed (governor valve oil pressure), and gearshift position (manual valve oil pressure). These valves move according to the forces and keep the transmission shifted into the correct gear ratio for the driving conditions.

## Kickdown Valve

The kickdown valve causes the transmission to shift into a lower gear during fast acceleration. A rod or cable links the carburetor or fuel injection throttle body

to a lever on the transmission. When the operator depresses the throttle, the lever moves the kickdown valve. This action causes hydraulic pressure to override normal shift control pressure and the transmission downshifts.

## Valve Body

The valve body contains many of the hydraulic valves, such as the pressure regulator, shift valves, manual valve, and others used in an automatic transmission. The valve body bolts to the bottom of the transmission case and is housed in the transmission pan. A filter or screen is attached to the bottom of the valve body. Passages in the valve body route fluid from the pump to the valves and then into the transmission case. Passages in the transmission case carry fluid to other hydraulic components.

To get an idea of how complicated the hydraulic system really is, a schematic view of an actual hydraulic system for an automatic transmission is shown in figure 4-41.

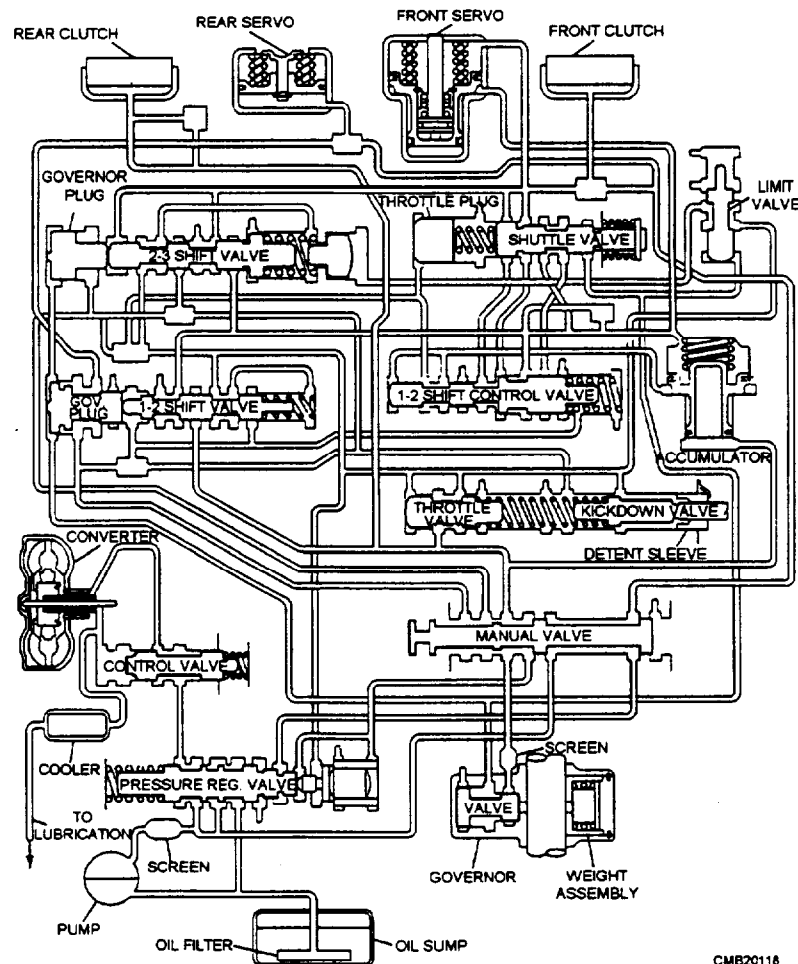

Figure 4-41.—Hydraulic schematic of a typical three-speed automatic transmission.

## AUTOMATIC TRANSMISSION SERVICE

Automatic transmission service can be easily divided into the following areas: preventive maintenance, troubleshooting, and major overhaul. Before you perform maintenance or repair on an automatic transmission, consult the maintenance manual for instructions and proper specifications. As a floor mechanic, however, your area of greatest concern is preventive maintenance. Preventive maintenance includes the following:

- Checking the transmission fluid daily
- Adjusting the shifting and kickdown linkages
- Adjusting lockup bands
- Changing the transmission fluid and filter at recommended service intervals

### Checking the Fluid

The operator is responsible for first echelon (operator's) maintenance. The operator should not only be trained to know to look for the proper fluid level but also know how to look for discoloration of the fluid and debris on the dipstick.

Fluid levels in automatic transmissions are almost always checked at operating temperature. This is important to know since the level of the fluid may vary as much as three quarters of an inch between hot and cold.

The fluid should be either reddish or clear. The color varies due to the type of fluid. (For example: construction equipment using OE-10 will be clear). A burnt smell or brown coloration of the fluid is a sign of overheated oil from extra heavy use or slipping bands or clutch packs. The vehicle should be sent to the shop for further inspection.

### CAUTION

Not all transmission fluids are the same. Before you add fluid, check the manufacturer's recommendations first. The use of the wrong fluid will lead to early internal parts failure and costly overhaul.

Overfilling the transmission can result in the fluid foaming and the fluid being driven out through the vent tube. The air that is trapped in the fluid is drawn into the hydraulic system by the pump and distributed to all parts of the transmission. This situation will cause air

to be in the transmission in place of fluid and, in turn, cause slow application and burning of clutch plates and facings. Slippage occurs, heat results, and failure of the transmission follows.

Another possible, but remote, problem is water, indicated by the fluid having a "milky" appearance. A damaged fluid cooling tube in the radiator (automotive) or a damaged oil cooler (construction) could be the problem. The remedy is simple. Pressure-test the suspected components and perform any required repairs. After repairs have been performed, flush and refill the transmission with clean, fresh fluid.

### Linkage and Band Adjustment

The types of linkages found on an automatic transmission are gearshift selection and throttle kick-down. The system can be a cable or a series of rod and levers. These systems do not normally present a problem, and preventive maintenance usually involves only a visual inspection and lubrication of the pivot points of linkages or the cable. When adjusting these linkages, you should strictly adhere to the manufacturer's specifications.

If an automatic transmission is being used in severe service, the manufacturer may suggest periodic band adjustment. Lockup bands are always adjusted to the manufacturer's specifications. Bands are adjusted by loosening the locknut and tightening down the adjusting screw to a specified value. The band adjusting screw is backed off a specified amount of turns and the locking nut tightened down. **NOT ALL BANDS ARE ADJUSTABLE.** Always check the manufacturer's service manual before any servicing of the transmission.

### Fluid Replacement

Fluid replacement is to be performed according to the manufacturer's recommendations. These recommendations vary considerably for different makes and models. When you change automatic transmission fluid, always read the service manual first.

Service intervals depend on the type of use the vehicle receives. In the NCF, because of the operating environment, more than a few of the vehicles are subjected to severe service. Severe service includes the following: hot and dusty conditions, constant stop and go driving (taxi service), trailer towing, constant heavy hauling, and around the clock operations (contingency). Any CESE operating in these conditions

should have its automatic transmission fluid and filter changed on a regular schedule, based on the manufacturer's specifications for severe service. Ensure the vehicle is on level ground or a lift and let the oil drain into a proper catchment device.

The draining of the transmission can be accomplished in one of the following three ways:

1. Removing the drain plug
2. Loosening the dipstick tube
3. Removing the oil pan

### CAUTION

Oil drained from automatic transmissions contains heavy metals and is considered hazardous waste and should be disposed of according to local naval station instructions.

Once the oil is drained, remove the pan completely for cleaning by paying close attention to any debris in the bottom of the pan. The presence of a high amount of metal particles may indicate serious internal problems. Clean the pan; set it aside.

All automatic transmissions have a filter or screen attached to the valve body. The screen is cleanable, whereas the filter is a disposable type and should always be replaced when removed. These are retained in different ways: retaining screws, metal retaining clamps, or O rings made of neoprene. Clean the screen with solvent and use low-pressure air to blow-dry it. Do not use rags to wipe the screen dry, as it tends to leave lint behind that will be ingested into the hydraulic system of the transmission. If the screen is damaged or is abnormally hard to clean, replace it.

Draining the oil from the pan of the transmission does not remove all of the oil—draining the oil from the torque converter completes the process. To do this, remove the torque converter cover and remove the drain plug, if so equipped. For a torque converter without a drain plug, special draining instructions may be found in the manufacturer's service manual. Before performing this operation, clear it with your shop supervisor.

### Refilling the Transmission

Reinstall the transmission oil pan, the oil plug, and the fill tube. Fill the transmission with the fluid prescribed by the manufacturer to the proper level. With the brakes applied, start the engine and let it idle

for a couple of minutes. Move the gear selector through all gear ranges several times, allowing the fluid to flow through the entire hydraulic system to release any trapped air. Return the selector lever to park or neutral and recheck the fluid level. Bring the fluid to the proper level. Run the vehicle until operating temperature is reached, checking for leaks. Also, recheck the fluid and adjust the level as necessary.

### CAUTION

Overfilling an automatic transmission will cause foaming of the fluid. This condition prevents the internal working parts from being properly lubricated, causing slow actuation of the clutches and bands. Eventual burning of the clutches and bands results. **DO NOT OVER-FILL AN AUTOMATIC TRANSMISSION.**

### REVIEW 3 QUESTIONS

- Q1. *In a vehicle equipped with an automatic transmission, operator control is limited to the selection of the gear range by moving a control lever. (T/F)*
- Q2. *In a torque converter, when does torque multiplication occur?*
- Q3. *What is the purpose of the stator in the torque converter?*
- Q4. *What are the three members of a planetary gearset?*
- Q5. *What is the purpose of the multiple-disc clutch in an automatic transmission?*
- Q6. *Where is the hydraulic pump of an automatic transmission located?*

### TRANSAXLES

Learning Objective: Identify components of the manual and automatic transaxles. State the differences between transmissions and transaxles.

A transaxle is a transmission and differential combination in a single assembly. Transaxles are used in front-wheel drive vehicles. A transaxle allows the wheels next to the engine to propel the vehicle. Short drive axles are used to connect the transaxle output to the hubs and drive wheels.

Vehicle manufacturers claim that a transaxle and front-wheel drive has several advantages over a

vehicle with rear-wheel drive. A few of these advantages are the following:

- Improved efficiency and reduced drive train weight
- Improved traction on slippery surfaces because of increased weight on the drive wheels
- Increased passenger compartment space (no hump in floorboard for rear drive shaft)
- Less unsprung weight (weight that must move with suspension action), thereby providing a smoother ride
- Quieter operation since engine and drive train noise is centrally located in the engine compartment
- Improved safety because of the increased mass in front of the passengers

Most transaxles are designed so that the engine can be transverse (sideways) mounted in the engine compartment. The transaxle bolts to the rear of the engine. This produces a very compact unit. Engine torque enters the transaxle transmission. The transmission transfers power to the differential. Then the differential turns the drive axles that rotate the front wheels.

Both manual and automatic transaxles are available. Manual transaxle uses a friction clutch and a standard transmission-type gearbox. An automatic transaxle uses a torque converter and a hydraulic system to control gear engagement.

## MANUAL TRANSAXLE

A manual transaxle uses a standard clutch and transmission. A foot-operated clutch engages and disengages the engine and transaxle. A hand-operated shift lever allows the operator to change gear ratios. The basic parts relating to a manual transaxle are as follows:

- Transaxle Input Shaft—main shaft splined to the clutch disc turns the gear in the transaxle.
- Transaxle Input Gears—either freewheeling or fixed gears on the input shaft and meshes with the output gears.
- Transaxle Output Gears—either fixed or freewheeling gears driven by the input gears.
- Transaxle Output Shaft—transfers torque to the ring gear, pinion gears, and differential.

- Transaxle Synchronizers—splined hub assemblies that can lock freewheeling gears to their shafts for engagement.
- Transaxle Differential—transfers gearbox torque to the driving axle and allows the axles to turn at different speeds.
- Transaxle Case—aluminum housing that encloses and supports parts of the transaxle.

The manual transaxle can be broken up into two separate units—a manual transaxle transmission and a transaxle differential. A manual transaxle transmission provides several (usually four or five) forward gears and reverse. You will find that the names of shafts, gears, and other parts in the transaxle vary, depending on the location and function of the components. For example, the input shaft may also be called the main shaft, and the output shaft is called the pinion shaft because it drives the ring and pinion gear in the differential. The output, or pinion, shaft has a gear or sprocket for driving the differential ring gear.

The clutch used on the manual transaxle transmission is almost identical to the manual transmission clutch for rear-wheel drive vehicles. It uses a friction disc and spring-loaded pressure plate bolted to the flywheel. Some transaxles used a conventional clutch release mechanism (release bearing and fork); others use a long pushrod passing through the input shaft.

The transaxle differential, like a rear axle differential, transfers power to the axles and wheels while allowing one wheel to turn at a different speed than the other. A small pinion gear on the gearbox output shaft or countershaft turns the differential ring gear. The ring gear is fastened to the differential case. The case holds the spider gears (pinion gears and axle side gears) and a pinion shaft. The axle shafts are splined to the differential side gears.

## AUTOMATIC TRANSAXLE

An automatic transaxle is a combination automatic transmission and differential combined into a single assembly. The basic parts of an automatic transaxle are as follows:

- Transaxle Torque Converter—(fluid-type clutch that slips at low speed but locks up and transfers engine power at a predetermined speed; couples and uncouples engine crankshaft to transmission input shaft and gear train).

- Transaxle Oil Pump—(produces hydraulic pressure to operate, lubricate, and cool the automatic transaxle; its pressure activates the pistons and servos).
- Transaxle Valve Body—(controls the flow of the fluid to the pistons and servos in the transaxle; it contains hydraulic valves operated by the operators shift linkage and by engine speed and load-sensing components).
- Transaxle Pistons and Servos—(operates the clutches and bands when activated by fluid pressure from the valve body).
- Transaxle Clutches and Bands—(applies planetary gears in the transaxle; different bands and clutches are activated to operate different units in the gear-sets).

- Transaxle Planetary Gearsets—(provides different gear ratios and reverse in the automatic transaxle).
- Transaxle Differential—(transfers powers from the transmission components to the axle shafts).

Many of the components used in the automatic transaxle are also found in the automatic transmission. Operating principles of these components are the same as the automatic transmission. The differential of the automatic transaxle is similar to that used on the manual transaxle.

#### **REVIEW 4 QUESTIONS**

- Q1. What is the purpose of the output shaft of a manual transaxle?*
- Q2. In an automatic transaxle, what component(s) operate(s) the clutches and bands?*

### **REVIEW 1 ANSWERS**

- Q1. Connects and disconnects the engine and manual transmission or transaxle*
- Q2. Clutch release mechanism*
- Q3. Clutch fork*
- Q4. Torsion spring*
- Q5. Clutch start switch*
- Q6. 1 1/2 inch*

### **REVIEW 2 ANSWERS**

- Q1. Aluminum*
- Q2. Input shaft, countershaft, reverse idler shaft, and main shaft*
- Q3. Locks the main shaft gear to the main shaft and prevents the gears from clashing during shifting*
- Q4. External rod and internal shift rail*
- Q5. Industrial and farm equipment*
- Q6. 7.55 to 1*

### **REVIEW 3 ANSWERS**

- Q1. True*
- Q2. When the impeller is spinning faster than the turbine*
- Q3. Redirects oil returning from the turbine and changes its rotation back to that of the impeller*
- Q4. Sun gear, ring gear, and planetary carrier*
- Q5. To transmit torque by locking elements of the planetary gearset to rotating members within the transmission*
- Q6. Located in the front of the transmission case and keyed to the torque converter hub*

### **REVIEW 4 ANSWERS**

- Q1. Transfer torque to the ring gear, the pinion gears, and the differential*
- Q2. Transaxle pistons and servos*



## CHAPTER 5

# DRIVE LINES, DIFFERENTIALS, DRIVE AXLES, AND POWER TRAIN ACCESSORIES

### INTRODUCTION

**Learning Objective:** Identify the components and explain the functions and the maintenance procedures for a drive line assembly, differentials, drive axles, a transfer case, and a power takeoff unit. Describe the different types of universal and constant velocity joints. Explain the adjustments and measurements of the ring and pinion gears. Describe the procedures for removing and replacing axle bearings and seals.

One important function of the power train is to transmit the power of the engine to the wheels. In a simple situation, a set of gears or a chain could perform this task, but automotive vehicles usually are not designed for such simple operating conditions. They are designed to have great pulling power, move at different speeds, operate forward and reverse, and travel on rough as well as smooth surfaces. To meet these widely varying conditions, a number of units have been added. In this chapter we will discuss drive lines, differentials, drive axles (rear and front drive), and power train accessories (transfer cases and power takeoffs).

### DRIVE LINE ASSEMBLY

**Learning Objective:** Identify the parts and the functions of different types of drive lines. Describe the different types of universal joints.

The drive line assembly has several important functions. It must perform the following:

- Send turning power from the transmission to the rear axle assembly.
- Flex and allow up-and-down movement of the rear axle assembly.
- Provide a sliding action to adjust for changes in drive line length.
- Provide a smooth power transfer.

The assembly provides a path through which power is transmitted from the transmission to the drive axle assemblies or auxiliary equipment. Vehicles, having a long wheelbase, are equipped with a drive

shaft that extends from the transmission or transfer case to a center support bearing and a drive shaft that extends from the center support bearing to the rear axle.

The drive line assembly (fig. 5-1) consists of the following:

- **SLIP YOKE**—connects the transmission output shaft to the front universal joint.
- **FRONT UNIVERSAL JOINT**—the swivel connection that fastens the slip yoke to the drive shaft.
- **DRIVE SHAFT**—a hollow metal tube that transfers turning power from the front universal joint to the rear universal joint.
- **REAR UNIVERSAL JOINT**—a flex joint that connects the drive shaft to the differential yoke.
- **REAR YOKE**—holds the rear universal joint and transfers torque to the gears in the rear axle assembly.

### SLIP YOKE (JOINT)

The type of transmission (manual or automatic) determines how the slip joint is connected to the drive shaft. On a manual transmission, the slip yoke is splined to the drive shaft with the yoke for the universal joint directly behind the transmission or transfer case, whereas, with the automatic transmission, the slip yoke is splined to the output shaft. Either way they serve the same purpose—to provide the necessary telescopic action for the drive shaft. As the axle housing moves forward and backward, the slip joint gives freedom of movement in a horizontal direction and yet is capable of transmitting rotary motion.

The slip yoke used with an automatic transmission has the outer diameter machined smooth. This smooth surface provides a bearing surface for the bushing and rear oil seal in the transmission. The transmission rear oil seal rides on the slip yoke and prevents fluid leakage out of the rear of the transmission. The seal also keeps dirt out of the transmission and off the slip yoke.

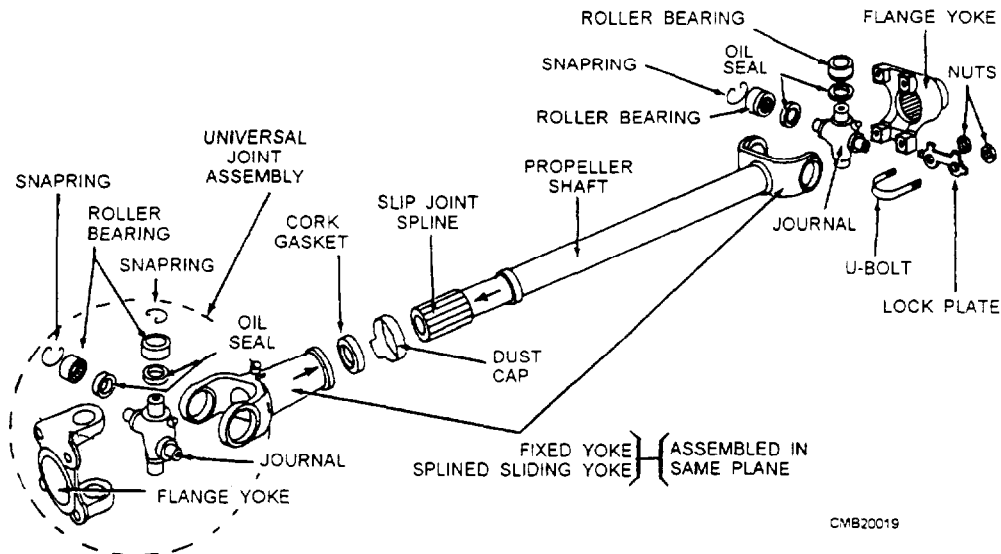

Figure 5-1.—Drive line assembly.

## DRIVE SHAFTS

The drive shaft, also called a propeller shaft, is commonly a hollow steel tube with yoke(s) welded on the end. The tubular design makes the drive shaft strong and light. Most vehicles use a single, one-piece drive shaft. However, many trucks have a two-piece drive shaft. This cuts the length of each shaft to avoid drive line vibration.

Since a drive shaft spins at full engine rpm in high gear, it must be straight and perfectly balanced (weight evenly distributed around center line of shaft). If NOT balanced, the shaft can vibrate violently. To prevent this vibration, drive shaft balancing weights are welded to the shaft at the factory. Small metal weights are attached to the light side to counteract the heavy side for smooth operation.

The drive shaft can be either open or enclosed, depending on the type of drive used. The HOTCHKISS drive has an open drive shaft that operates a rear axle assembly mounted on springs (fig. 5-2). The HOTCHKISS drive requires that the springs be rigid enough to withstand the twisting action (torque) of the rear axle and the driving and braking forces that the springs transmit to the frame. This type of drive is common to the equipment you will encounter in the Navy.

Another type of drive is a torque tube. Torque tubes differ from the Hotchkiss design in that a solid drive shaft is enclosed in a hollow torque tube and rotates within a support bearing to prevent whipping. One universal joint is used at the front of the drive

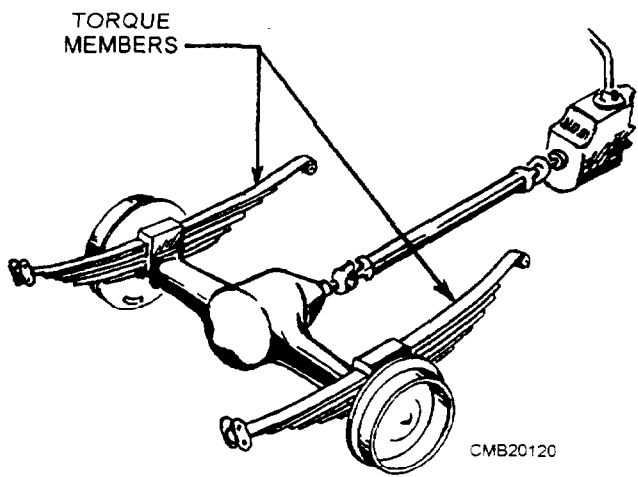

Figure 5-2.—Hotchkiss drive.

shaft, and the rear of the drive shaft is attached to the axle drive pinion through a flexible coupler.

## UNIVERSAL JOINTS

A universal joint, also called a U-joint, is a flexible coupling between two shafts that permits one shaft to drive another at an angle to it. The universal joint is flexible in a sense that it will permit power to be transmitted while the angle of the other shaft is continually varied.

A simple universal joint is composed of three fundamental units consisting of a journal (cross) and

two yokes (fig. 5-3). The two yokes are set at right angles to each other and their open ends are connected by the journal. This construction permits each yoke to pivot on the axis of the journal and also permits the transmission of rotary motion from one yoke to the other. As a result, the universal joint can transmit power from the engine through the shaft to the rear axle, even though the engine is mounted in the frame at a higher level than the rear axle, which is constantly moving up and down in relation to the engine.

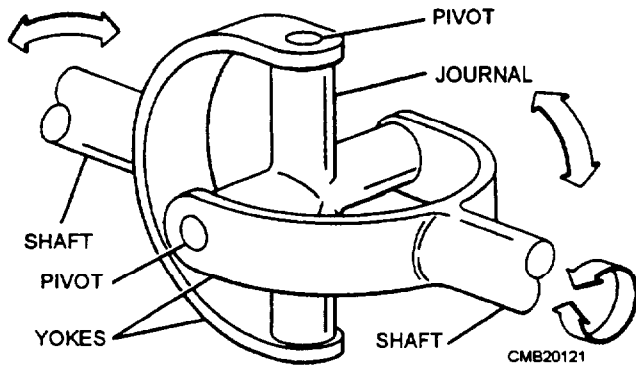

Figure 5-3.—Simple universal joint.

A peculiarity of the conventional universal joint is that it causes a driven shaft to rotate at a variable speed in respect to the driving shaft. There is a cyclic variation in the form of an acceleration and deceleration of speed (fig. 5-4). Two universal joints are placed in a drive shaft to eliminate the speed fluctuations of the shaft while the shaft is at an angle to the power source. The universal joints are placed at a 90-degree angle to each other and one counteracts the action of the other while in motion.

Three common types of automotive drive shaft universal joints are used on rear-wheel drive vehicles: cross and roller, ball and trunnion, and double-cardan (constant velocity) universal joints.

### Cross and Roller Universal Joint

The cross and roller design is the most common type of drive shaft U-joint. It consists of four bearing caps, four needle roller bearings, a cross or journal, grease seals, and snap rings (fig. 5-5).

The bearing caps are held stationary in the drive shaft yokes. Roller bearings fit between the caps and the cross to reduce friction. The cross is free to rotate inside the caps and yokes. Snap rings usually fit into grooves cut in the caps or the yoke bores to secure the bearing caps and bearings. There are several other methods of securing the bearing caps in the yokes. These are bearing covers, U-bolts, and bearing caps.

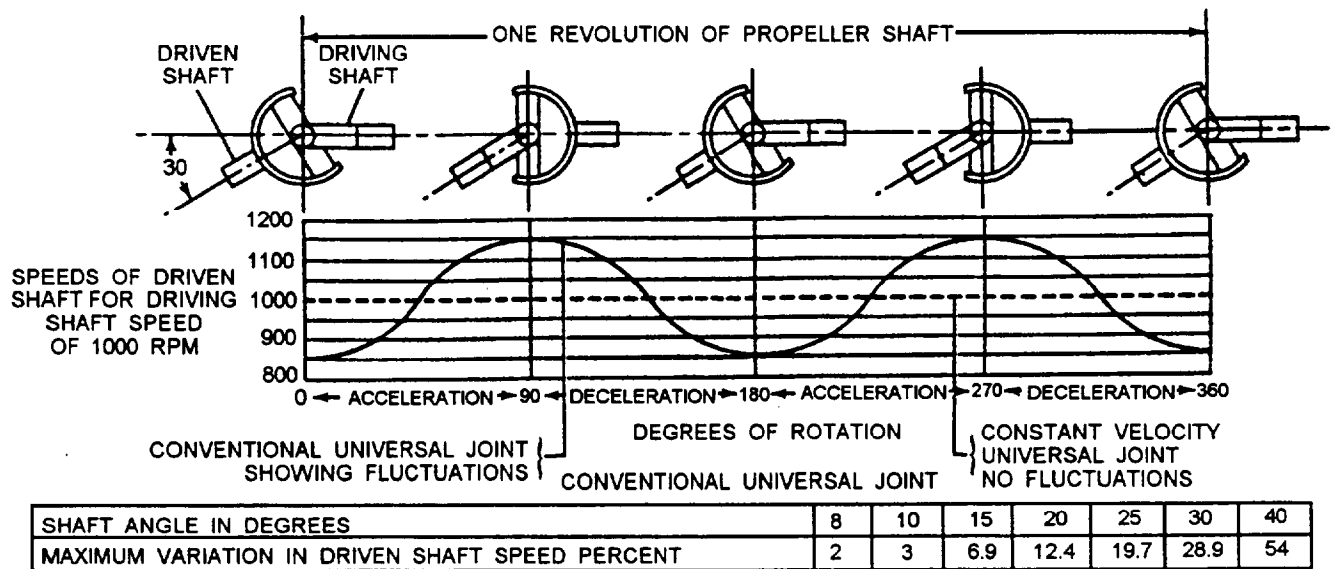

CMB20122

Figure 5-4.—Speed fluctuations caused by conventional universal joints.

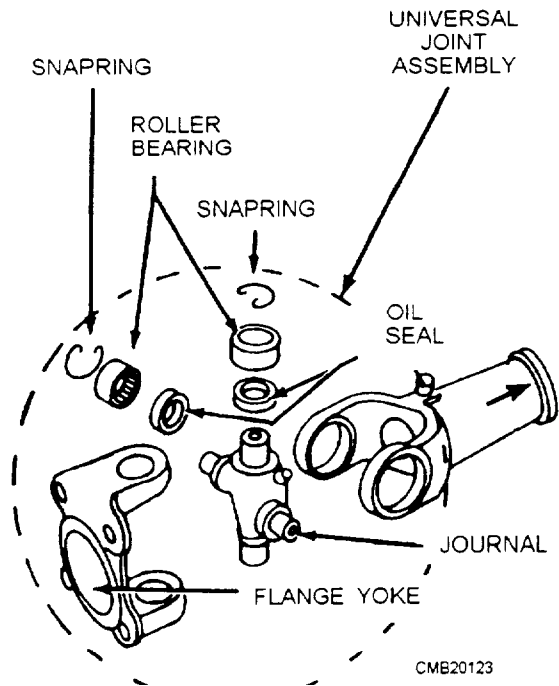

Figure 5-5.—Cross and roller universal joint—disassembled view.

### Ball and Trunnion Universal Joint

The ball and trunnion universal joint is a T-shaped shaft that is enclosed in the body of the joint (fig. 5-6). The trunnion ends are each equipped with a ball, mounted in needle bearings, and move freely in grooves in the outer body of the joint, in effect,

creating a slip joint. Compensating springs at each end of the drive shaft hold it in a centered position.

Variations in length is permitted by the longitudinal movement of the balls in the body grooves. Angular displacement is allowed by outward movement of the balls on the trunnion pins. This type of universal joint is recognized easily by the flexible dust boot that covers it.

### Double-Cardan Universal Joint

The double-cardan universal joint uses two cross and roller joints in tandem to form a single joint (fig. 5-7). The joints are linked through a centering yoke that works in conjunction with a specially designed spring-loaded centering ball. The components are contained within the centering coupling yoke.

As the shafts rotate, the action of the centering ball and yoke acts to maintain an equally divided drive angle between the connected shafts, resulting in a constant drive velocity.

### CONSTANT VELOCITY (CV) JOINTS

The speed fluctuations caused by the conventional universal joints do not cause much difficulty in the rear-wheel drive shaft where they have to drive through small angles only. In front-wheel drives, the wheels are cramped up to 30 degrees in steering. For this reason velocity fluctuations present a serious problem. Conventional universal joints would cause

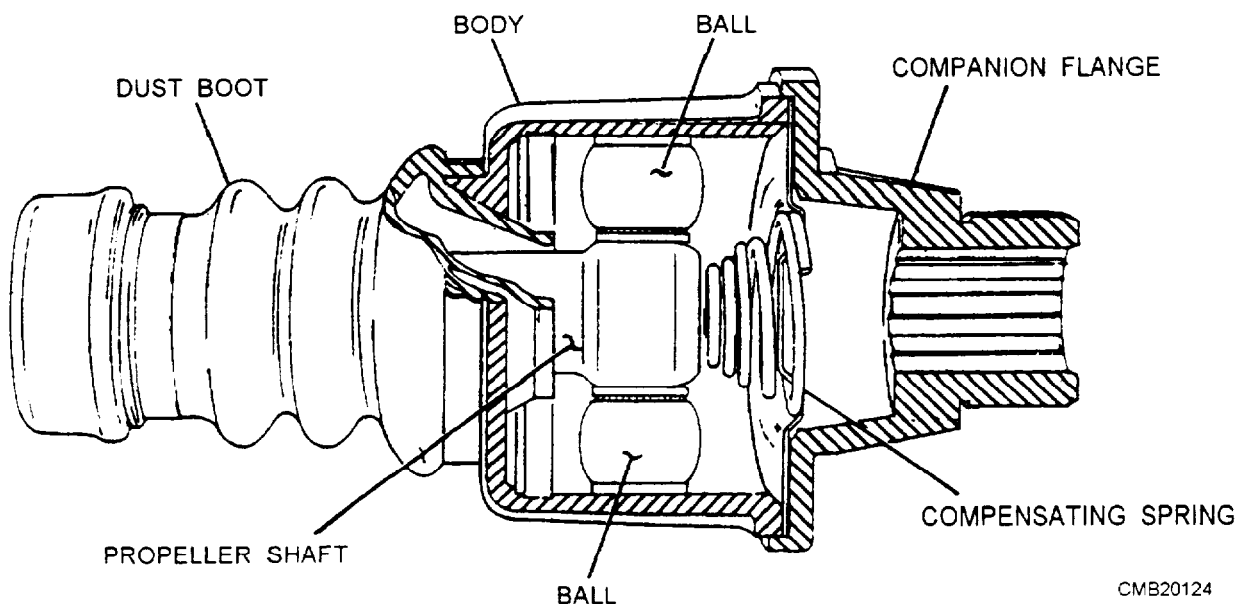

Figure 5-6.—Ball and trunnion universal joint.

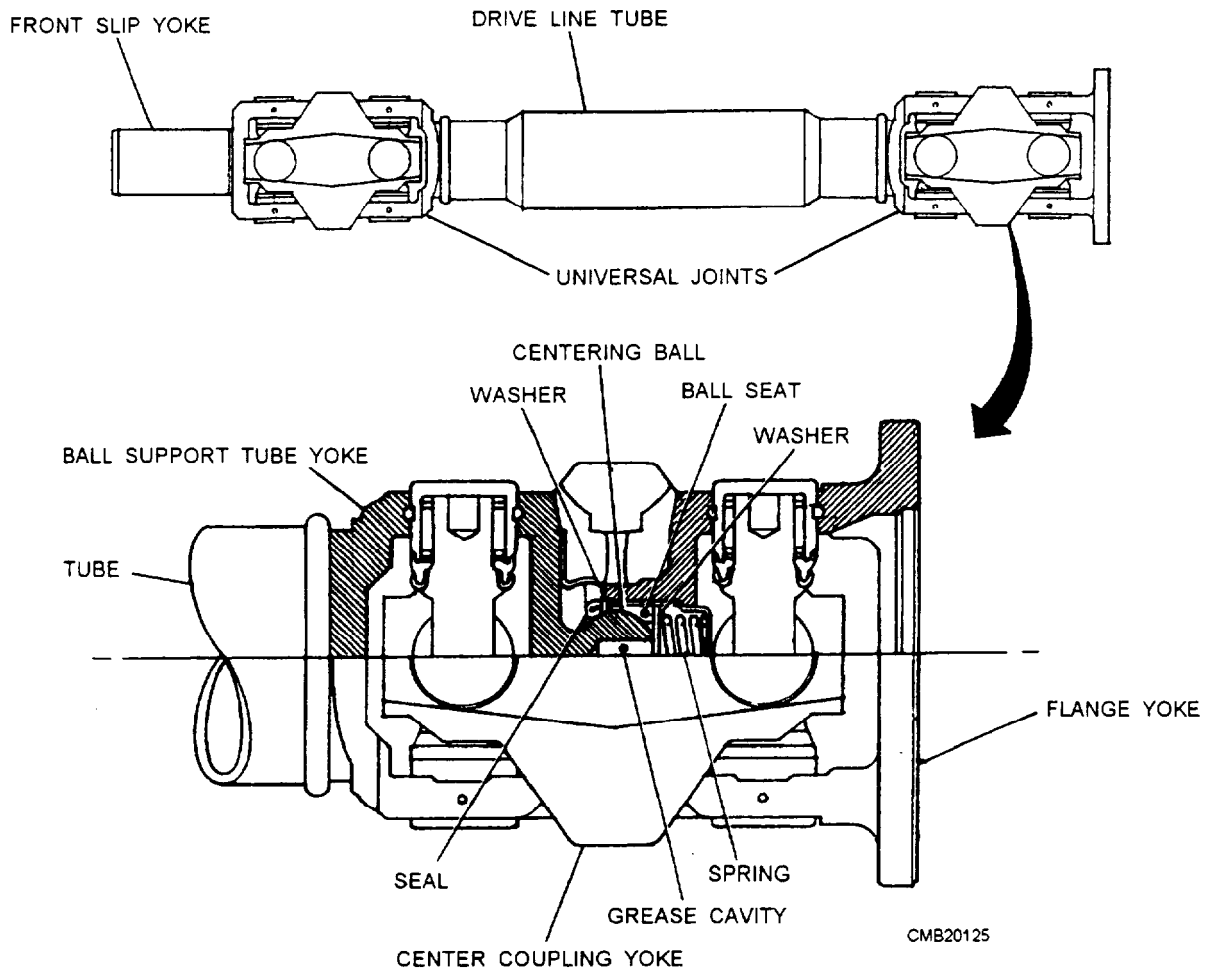

Figure 5-7.—Double-cardan universal joint.

hard steering, slippage, and tire wear each time the vehicle turns a corner. Constant velocity joints eliminate the pulsations because they are designed to be used exclusively to connect the front axle shaft to the driving wheels.

Basic operation of a CV joint is as follows:

- The outboard CV joint is a fixed joint that transfers rotating power from the axle shaft to the hub assembly.
- The inboard CV joint is a sliding joint that functions as a slip joint in a drive shaft for rear-wheel drive vehicles.

The constant velocity joints you will normally encounter are the Rzeppa, Bendix-Weiss, and tripod types.

### Rzeppa Constant Velocity (CV) Joint

The Rzeppa constant velocity (CV) joint is a ball-bearing type in which the balls furnish the only points

of driving contact between the two halves of the coupling. A Rzeppa CV joint consists of a star-shaped inner race, several ball bearings, bearing cage, outer race or housing, and a rubber boot (fig. 5-8).

The inner race (driving member) is splined to the inner axle shaft. The outer race (driven member) is a spherical housing that is an integral part of the outer shaft; the balls and ball cage are fitted between the two races. The close spherical fit between the three main members supports the inner shaft whenever it is required to slide in the inner race, relieving the balls of any duty other than the transmission of power.

The movement of the balls is controlled by the ball cage. The ball cage positions the balls in a plane at right angles to the two shafts when the shafts are in the same line. A pilot pin, located in the outer shaft, moves the pilot and the ball cage by simple leverage in such a manner that the angular movement of the cage and balls is one half of the angular movement of the driven shaft. For example, when the driven shaft is moved 20

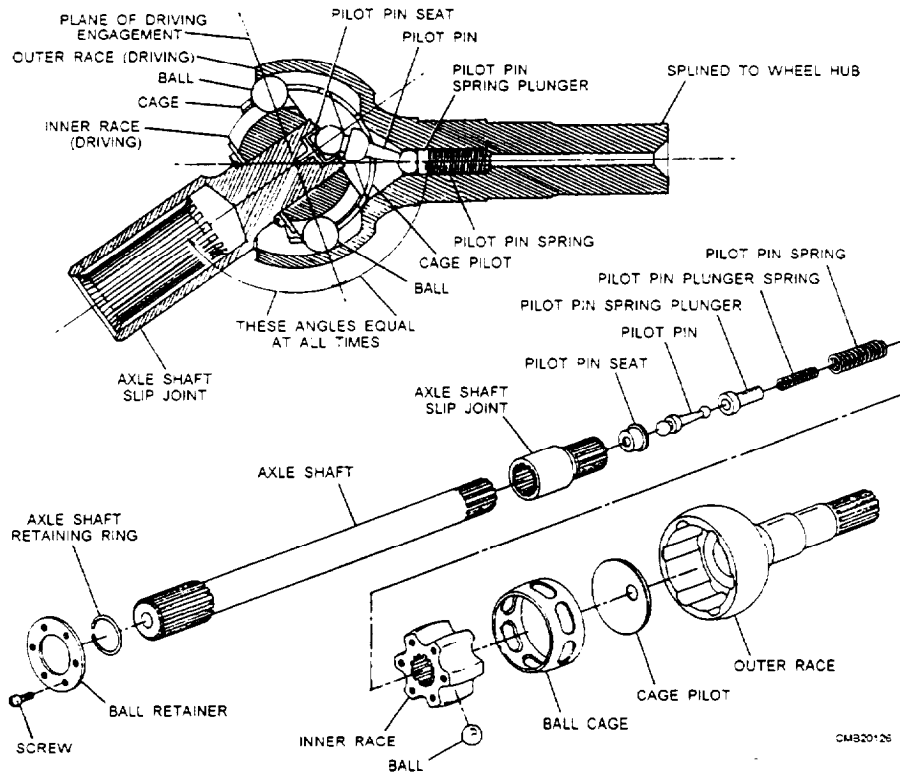

Figure 5-8.—Rzeppa constant velocity (CV) joint.

degrees, the cage and balls move 10 degrees. As a result, the balls of the Rzeppa joint are positioned, from the top view, to bisect the angle formed.

### Bendix-Weiss Constant Velocity (CV) Joint

The Bendix-Weiss constant velocity (CV) joint also uses balls that furnish points of driving contact,

but its construction differs from that of the Rzeppa in that the balls are a tight fit between two halves of the coupling and that no cage is used (fig. 5-9). The center ball rotates on a pin inserted in the outer race and serves as a locking medium for the four other balls.

The driving contact remains on the plane that bisects the angle between the two shafts; however, it is the rolling friction between the four balls and the

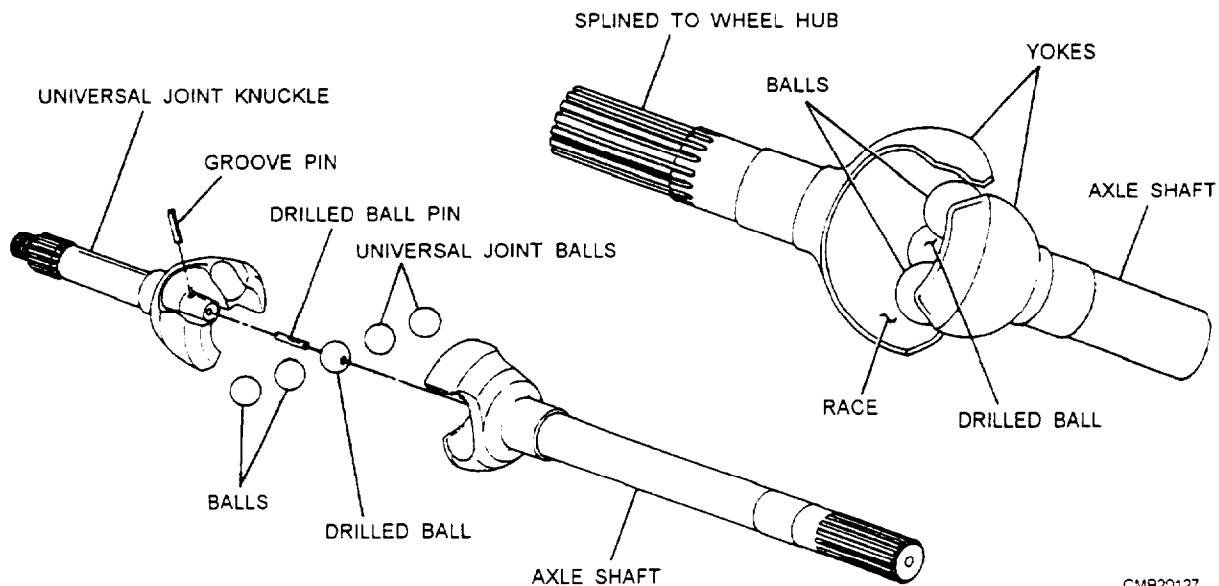

Figure 5-9.—Bendix-Weiss constant velocity (CV) joint.

universal joint housing that positions the balls. When both shafts are in line, that is, at an angle of 180 degrees, the balls lie in a plane that is 90 degrees to the shafts. If the driving shaft remains in the original position, any movement of the driven shaft will cause the balls to move one half of the angular distance. For example, when the driven shaft moves through an angle of 20 degrees, the angle between the two shafts is reduced to 160 degrees. The balls will move 10 degrees in the same direction, and the angle between the driving shaft and the plane in which the balls lie will be reduced to 80 degrees. This action fulfills the requirement that the balls lie in the plane that bisects the angle of drive.

### Tripod Joint

A tripod or ball and housing CV joint consists of a spider, usually three balls, needle bearings, outer yoke, and boot. The inner spider is splined to the axle shaft with the needle bearings and three balls fitting around the spider. The yoke then slides over the balls. Slots in the yoke allow the balls to slide in and out and also swivel.

During operation, the axle shaft turns the spider and ball assembly. The balls transfer power to the outer housing. Since the outer housing is connected to the axle stub shaft or hub, power is sent through the joint to propel the vehicle.

### CENTER SUPPORT BEARINGS

When two or more drive shafts are connected in tandem, their alignment is maintained by a rubber bushed center support bearing (fig. 5-10). The center

support bearing bolts to the frame or underbody of the vehicle. It supports the center of the drive shaft where the two shafts come together.

A sealed ball bearing allows the drive shaft to spin freely. The outside of the ball bearing is held by a thick, rubber, doughnut-shaped mount. The rubber mount prevents vibration and noise from transferring into the operator's compartment.

A bearing similar to the center support bearing is often used with long drive lines, containing a single drive shaft. This bearing is called a **PILLOW BLOCK BEARING**. It is commonly used in drive lines that power auxiliary equipment. Its purpose is to provide support for the drive shaft and maintain alignment. When used at or near the center of the shaft, it reduces the whipping tendency of the shaft at high speed or when under heavy loads. The construction of pillow blocks varies. The simplest form is used on solid power takeoff drive shafts, which is no more than a steel sleeve with a bronze bushing.

### DRIVE LINE MAINTENANCE

A drive line is subjected to very high loads and rotating speeds. When a vehicle is cruising down the road, the drive shaft and universal joints or constant velocity joints may be spinning at full engine rpm. They are also sending engine power to either the front or rear axle assemblies. This makes drive line maintenance very important.

The drive shafts must be perfectly straight and the joints must be unworn to function properly. If any component allows the drive shafts to wobble, severe vibration, abnormal noises, or even major damage can result.

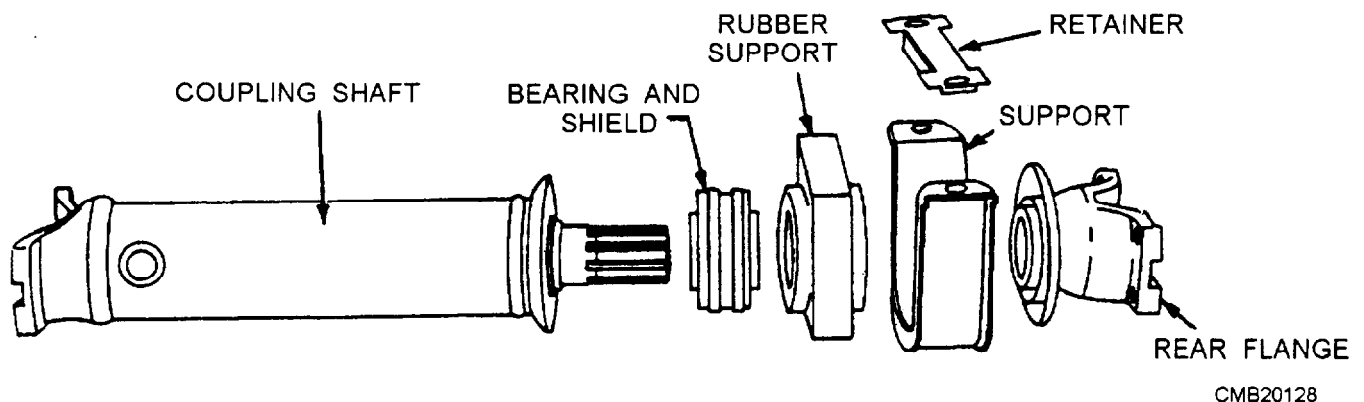

Figure 5-10.—Center support bearing.

## Drive Shaft Noises

When operating a vehicle to verify a complaint, keep in mind that other components could be at fault. A worn wheel bearing, squeaking spring, defective tire, transmission, or differential troubles could be at fault. You must use your knowledge of each system to detect which component is causing the trouble.

Drive shaft noises are usually caused by worn U-joints, slip joint wear, or a faulty center support bearing. Drive shaft noises and possible causes are as follows:

- Grinding and squeaking from the drive shaft is frequently caused by worn universal joints. The joints become dry, causing the rollers to wear. The unlubricated, damaged rollers then produce a grinding or squeaking sound, as they operate on the scored cap and cross surfaces.
- A clunking sound, when going from acceleration to deceleration or deceleration to acceleration, may be caused by slip yoke problems. The splines may be worn. The yoke transmission extension housing bushing may also be worn. This will let the yoke move up and down with changes in drive line torque. An excessively worn U-joint or differential problem can also cause a similar noise.
- A whining sound from the drive shaft is sometimes caused by a dry, worn center support bearing. Since this bearing makes complete revolutions, it will make a different sound than a bad universal joint. A high pitched, more constant, whine will usually come from a faulty center support bearing.

Any other abnormal sound should be traced using your knowledge of mechanics, a stethoscope, and the vehicle's service manual troubleshooting chart.

## Drive Shaft Inspection

To inspect the drive shaft for wear or damage, raise the vehicle and place it on jack stands. Look for undercoating or mud on the drive shaft. Check for missing balance weights, cracked welds, and other drive shaft problems.

To check for working U-joints, wiggle and rotate each U-joint back and forth. Watch the universal joint carefully. Try to detect any play between the cross and the yoke. If the cross moves inside the yoke, the U-joint is worn and needs to be replaced.

Also, wiggle the slip yoke up and down. If it moves in the transmission bushing excessively, either the

yoke or the bushing is worn. Inspect the rear yoke bolts for tightness. Make sure the rear motor mount is NOT broken. Look at any condition that can upset the operation of the drive shaft.

If after a thorough check of the drive shaft you fail to determine the problem, notify the shop supervisor. The drive shaft may require detailed measuring (drive shaft runout and drive shaft angle) or have its balance checked.

## Universal Joint Service

The universal joints on many automotive vehicles are factory lubricated. However, construction equipment have universal joints that have lubrication fittings that should be lubricated at regular intervals.

Service to universal joints that are factory lubricated is limited to replacement when signs of excessive wear are present. The universal joints provided with lubrication fittings are only lubricated with a hand operated low-pressure grease guns. Use of a high-pressure grease gun will damage the seals, resulting in early failure of the universal joint.

Another area to be concerned with when servicing the universal joints is the slip yoke (joint). Slip yokes may be lubricated from the transmission or lubricated through a lubrication fitting.

### NOTE

Always consult the manufacturer's service manual for lubrication intervals and proper lubricants to be used.

A worn universal joint is the most common drive line problem, causing squeaking, grinding, clunking, or clicking sounds. The grease inside the joint can dry out. The roller bearings will wear small indentations in the cross. When the bearings try to roll over these dents, a loud metal-on-metal grinding or chirp sound can result.

Quite often, a worn U-joint is discovered when the transmission is placed in REVERSE. When the vehicle is backed up, the roller bearing is forced over the wear indentation against normal rotation. When this occurs, the rollers will catch on the sharp edges in the worn joint, causing even a louder sound.

**UNIVERSAL JOINT DISASSEMBLY.**—The universal joint may require removal and disassembly to enable you to check the condition of the joint



physically. Steps for the removal and disassembly of a U-joint are as follows:

1. Raise the vehicle and place it on jack stands.
2. Scribe the alignment marks on the differential yoke and universal joint, so drive shaft balance is ensured upon reassembly.
3. Unbolt the rear joint from the differential. If used, also unbolt the center support bearing. Pry the shaft forward and lower the shaft slightly.

### CAUTION

Do NOT allow the full weight of the drive shaft to hang from the slip yoke. Support the drive shaft to prevent damage to the extension housing, rear bushing, and front U-joint.

4. Wrap the tape around the caps to prevent them from falling off and spilling the roller bearings.
5. Slide the drive shaft out of the transmission. If the transmission lubricant begins to leak, install a plastic plug into the extension housing.
6. Before disassembling the universal joint, especially constant velocity joints, scribe mark each component. The marks will show you how to reassemble the joint.
7. Clamp the drive shaft yoke in a vise. Do NOT clamp the weaker center section of the drive shaft or it will bend. If used, remove the snap rings, using a screwdriver, snap-ring pliers, or needle nose pliers.

### CAUTION

Wear safety glasses to protect your eyes in case the snap rings fly out of the universal joint during removal.

8. Use two sockets—one LARGER than the bearing cap and one SMALLER than the bearing cap. Place the SMALLER socket on the bearing cap of the universal joint (fig. 5-11). The LARGER socket is to be placed over the outside diameter of the bearing cap on the opposite side of the joint (fig. 5-11).
9. With both sockets and the universal inside the vise, slowly tighten the vise to force the bearing caps out of the yoke. Use the same procedure on the remaining bearing caps, as required.

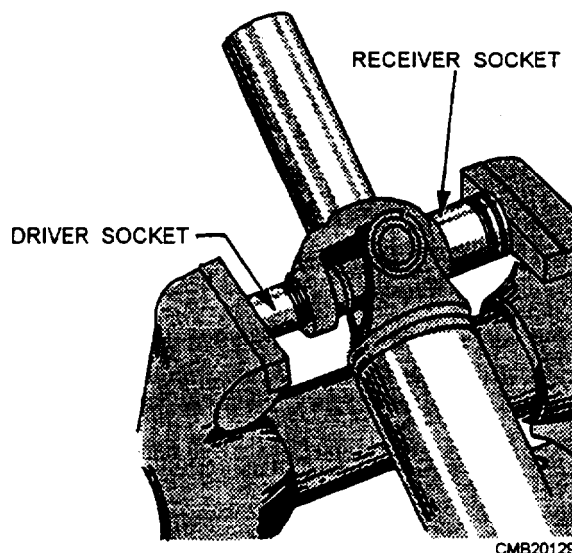

Figure 5-11.—Universal joint removal.

Normally, a universal joint is replaced anytime it is disassembled. However, if the joint is relatively new, you can inspect, lubricate, and reassemble it.

During the inspection, clean the roller bearings and other parts in solvent. Then check the cross and rollers for signs of wear. If the slightest sign of roughness or wear is found on any part, REPLACE the U-joint.

**UNIVERSAL JOINT REASSEMBLY.**—Once the U-joint has been cleaned and inspected and found to be in a serviceable condition, it must be reassembled. Steps for reassembling a U-joint are as follows:

1. Pack the roller bearings in high-temperature grease. A good method of keeping the bearing in place is to fill the bearing cap with grease.
2. Position the cross inside the yoke. Align your marks. Then fit the bearing caps into each end of the yoke.
3. Center the cross partially into each cap to keep the roller bearing from falling.
4. Place the assembly in a vise. Tighten the vise so that the bearing caps are forced into the yoke.

### WARNING

If the bearing cap fails to press into place with normal pressure, disassemble the joint and check the roller bearings. It is easy for a roller bearing to fall and block cap installation. If you try to force the cap with excess pressure, the universal and drive shaft could be damaged.

5. Press the caps fully into position by placing a small socket on one bearing cap. Tighten the vise until the cap is pushed in far enough to install the snap ring. With one snap ring in place, use the socket to force the other cap into position. Install its snap ring.
6. Repeat this procedure on the other universal joint, if needed.

After assembly, check the action of the U-joint. Swing it back and forth into various positions. The joint should move freely, without binding. Double-check that all snap rings have been installed properly. Once the U-joint has been checked and is working properly, reinstall the drive shaft back into the vehicle as follows:

1. Wipe off the outside slip yoke and place a small amount of grease on the internal splines. Align the marks and slide the yoke into the rear of the transmission.
2. Push the slip yoke all the way into the extension housing and position the rear U-joint at the differential.
3. Pull back on the drive shaft and center the rear universal properly. Check your rear alignment marks.
4. Install the U-bolts, bearing caps, or yoke bolts to secure the rear universal joint.
5. With the rear universal joint secured, lower the vehicle to the ground.
6. Test-drive the vehicle for proper operation. Check for unusual noises, vibration, and other abnormalities.

### **Constant Velocity Joint Service**

Constant velocity joint service requires the disassembly of the joint. Refer to the service manual for the vehicle when servicing a CV joint. The manual will give special detailed directions that are required depending on the type of joint.

Once the CV joint is disassembled, obtain a CV joint repair kit (usually includes new joint components, grease, boot, and bootstraps). When the joint is being assembled, refer back to the service manual for detailed directions.

### **WARNING**

Always use the recommended type of grease on a CV joint. The wrong type of grease

will cause boot deterioration and joint failure. CV joint kits provide the correct type and amount of grease required.

After reassembling the CV joint, fit the boot over the joint. Make sure the boot ends fit into their grooves. Install the bootstraps. Do not overtighten the straps, as they may cut the boot or break.

### **Center Support Bearing Service**

The center support bearing is normally prelubricated and sealed at the factory. However, some support bearings have lubrication fittings and require lubrication at regular intervals. Even though lubrication extends the useful life of the bearing, they eventually wear out. The first indication of support bearing failure is excessive chassis vibration at low speed. This is caused by the bearing turning with the drive shaft in the rubber support.

When a faulty bearing is suspected, it should be inspected for wear and damage. If the rubber support shows any evidence of hardening, cracking, or tearing, it should be replaced.

Should you encounter a faulty support bearing, replacement procedures are usually limited to separating the drive shafts, unbolting the bearing support from the frame or cross member, and sliding the bearing and support assembly from the shaft.

If only the bearing is available from the parts room, disassemble the unit by gently prying the bearing out of the rubber support. Next, remove the dust shield from the bearing. All parts that are to be reused should be cleaned. When the bearing is being replaced, some manufacturers recommend that waterproof grease be placed on both sides of the bearing, not for a lubricant but to exclude water and dust from the bearing. Install the dust shield and press the new bearing into the support.

Before securing the bearing support to the frame or cross member, check the service manual to determine if shims are required for alignment purposes. When reassembling support bearings, you should exercise care to ensure that proper alignment of the drive line is maintained. This will prevent abnormal wear of the universal joints.

### **REVIEW 1 QUESTIONS**

- Q1. What are the four functions of a drive line assembly?*

- Q2. The movement of the rear axle assembly also causes the distance between the rear axle and transmission to change. (T/F)
- Q3. When is a center support bearing needed and why?
- Q4. Grinding or squeaking from the drive shaft is frequently caused by \_\_\_\_\_
- Q5. How do you check for worn universal joints?
- Q6. If a universal joint fails to press together with normal force, it is possible that one of the needle bearings has fallen out of place. (T/F)

## DIFFERENTIALS

**Learning Objective:** Identify differential design variations. Describe the principles of the limited slip differential. Explain basic service and repair of a differential. Explain the adjustment of the ring and pinion gears.

Another important unit in the power train is the differential, which is driven by the final drive. The differential is located between the axles and permits one axle to turn at a different speed from that of the other. The variations in axle speed are necessary when a vehicle rounds a corner or travels over uneven ground. At the same time, the differential transmits engine torque to the drive axles. The drive axles are on a rotational axis that is 90 degrees different than the rotational axis of the drive shaft.

### DIFFERENTIAL CONSTRUCTION

A differential assembly uses drive shaft rotation to transfer power to the axle shafts. The term *differential* can be remembered by thinking of the words *different* and *axle*. The differential must be capable of providing torque to both axles, even when they are turning at different speeds. The differential assembly is constructed from the following: the differential carrier, the differential case, the pinion gear, the ring gear, and the spider gears (fig. 5-12).

#### Differential Carrier

The differential carrier provides a mounting place for the pinion gear, the differential case, and other differential components. There are two types of differential carriers: the removable type and the integral (unitized) type.

- **REMOVABLE TYPE**—a carrier that bolts to the front of the axle housing. Stud bolts are installed in the housing to provide proper carrier

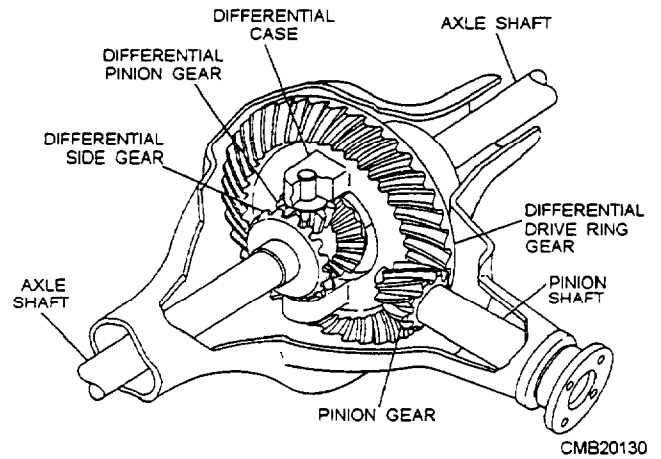

Figure 5-12.—Conventional differential.

alignment. A gasket is installed between the carrier and the housing to prevent leakage.

- **INTEGRAL TYPE**—a carrier that is constructed as part of the axle housing. A stamped metal or cast aluminum cover bolts to the rear of the carrier for inspection of the gears.

#### Differential Case

The differential case holds the ring gear, the spider gears, and the inner ends of the axles. It mounts and rotates in the carrier. Case bearings fit between the outer ends of the differential case and the carrier.

#### Pinion Gear

The pinion gear turns the ring gear when the drive shaft is rotating. The outer end of the pinion gear is splined to the rear U-joint companion flange or yoke. The inner end of the pinion gear meshes with the teeth on the ring gear.

The pinion gear is mounted on tapered roller bearings that allow the pinion gear to move freely on the carrier. Either a crushable sleeve or shims are used to preload the pinion gear bearings. Some differentials use a pinion pilot bearing that supports the extreme inner end of the pinion gear. The pinion pilot bearing assists the tapered roller bearings in supporting the pinion gear during periods of heavy loads.

#### Ring Gear

The pinion gear drives the ring gear. It is bolted securely to the differential case and has more teeth than the pinion gear. The ring gear transfers rotating power through an angle change or 90 degrees.

The ring and pinion gears are a matched set. They are lapped (meshed and spun together with an abrasive compound on the teeth) at the factory. Then one tooth on each gear is marked to show the correct teeth engagement. Lapping produces quieter operation and assures longer gear life.

### Spider Gears

The spider gears are a set of small bevel gears that include two axle gears (differential side gears) and two pinion gears (differential idler gears). The spider gears mount inside the differential case. A pinion shaft passes through the two pinion gears and case. The two side gears are splined to the inner ends of the axles.

### FINAL DRIVE

A final drive is that part of a power transmission system between the drive shaft and the differential. Its function is to change the direction of the power transmitted by the drive shaft through 90 degrees to the driving axles. At the same time, it provides a fixed reduction between the speed of the drive shaft and the axle driving the wheels.

The reduction or gear ratio of the final drive is determined by dividing the number of teeth on the ring gear by the number of teeth on the pinion gear. In passenger vehicles, this speed reduction varies from about 3:1 to 5:1. In trucks it varies from about 5:1 to 11:1. To calculate rear axle ratio, count the number of teeth on each gear. Then divide the number of pinion teeth into the number of ring gear teeth. For example, if the pinion gear has 10 teeth and the ring gear has 30 (30 divided by 10), the rear axle ratio would be 3:1. Manufacturers install a rear axle ratio that provides a compromise between performance and economy. The average passenger car ratio is 3.50:1.

The higher axle ratio, 4.11:1 for instance, would increase acceleration and pulling power but would decrease fuel economy. The engine would have to run at a higher rpm to maintain an equal cruising speed.

The lower axle ratio, 3:1, would reduce acceleration and pulling power but would increase fuel mileage. The engine would run at a lower rpm while maintaining the same speed.

The major components of the final drive include the pinion gear, connected to the drive shaft, and a bevel gear or ring gear that is bolted or riveted to the differential carrier. To maintain accurate and proper alignment and tooth contact, the ring gear and

differential assembly are mounted in bearings. The bevel drive pinion is supported by two tapered roller bearings, mounted in the differential carrier. This pinion shaft is straddle mounted, meaning that a bearing is located on each side of the pinion shaft teeth. Oil seals prevent the loss of lubricant from the housing where the pinion shaft and axle shafts protrude. As a mechanic, you will encounter the final drive gears in the spiral bevel and hypoid design, as shown in figure 5-13.

### Spiral Bevel Gear

Spiral bevel gears have curved gear teeth with the pinion and ring gear on the same center line. This type of final drive is used extensively in truck and occasionally in older automobiles. This design allows for constant contact between the ring gear and pinion. It also necessitates the use of heavy grade lubricants.

### Hypoid Gear

The hypoid gear final drive is an improvement or variation of the spiral bevel design and is commonly used in light and medium trucks and all domestic rear-wheel drive automobiles. Hypoid gears have replaced spiral bevel gears because they lower the hump in the floor of the vehicle and improve gear-meshing action.

As you can see in figure 5-13, the pinion meshes with the ring gear below the center line and is at a slight angle (less than 90 degrees). This angle and the use of

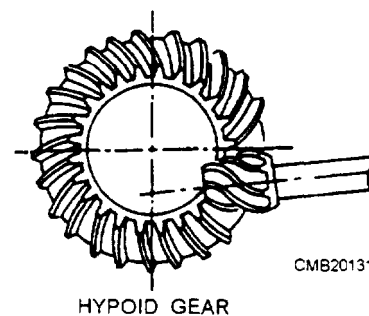
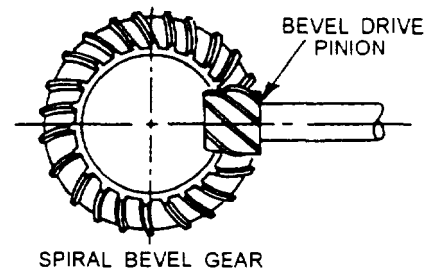

Figure 5-13.—Types of final drives.

heavier (larger) teeth permit an increased amount of power to be transmitted while the size of the ring gear and housing remain constant.

The tooth design is similar to the spiral bevel but includes some of the characteristics of the worm gear. This permits the reduced drive angle. The hypoid gear teeth have a more pronounced curve and steeper angle, resulting in larger tooth areas and more teeth to be in contact at the same time. With more than one gear tooth in contact, a hypoid design increases gear life and reduces gear noise. The wiping action of the teeth causes heavy tooth pressure that requires the use of heavy grade lubricants.

### Double-Reduction Final Drive

In the final drives shown in figure 5-13, there is a single fixed gear reduction. This is the only gear

reduction in most automobiles and light- and some medium-duty trucks between the drive shaft and the wheels.

Double-reduction final drives are used for heavy-duty trucks. With this arrangement (fig. 5-14) it is not necessary to have a large ring gear to get the necessary gear reduction. The first gear reduction is obtained through a pinion and ring gear as the single fixed gear reduction final drive. Referring to figure 5-14, notice that the secondary pinion is mounted on the primary ring gear shaft. The second gear reduction is the result of the secondary pinion which is rigidly attached to the primary ring gear, driving a large helical gear which is attached to the differential case. Double-reduction final drives may be found on military design vehicles, such as the 5-ton truck. Many commercially designed vehicles of this size use a single- or double-reduction

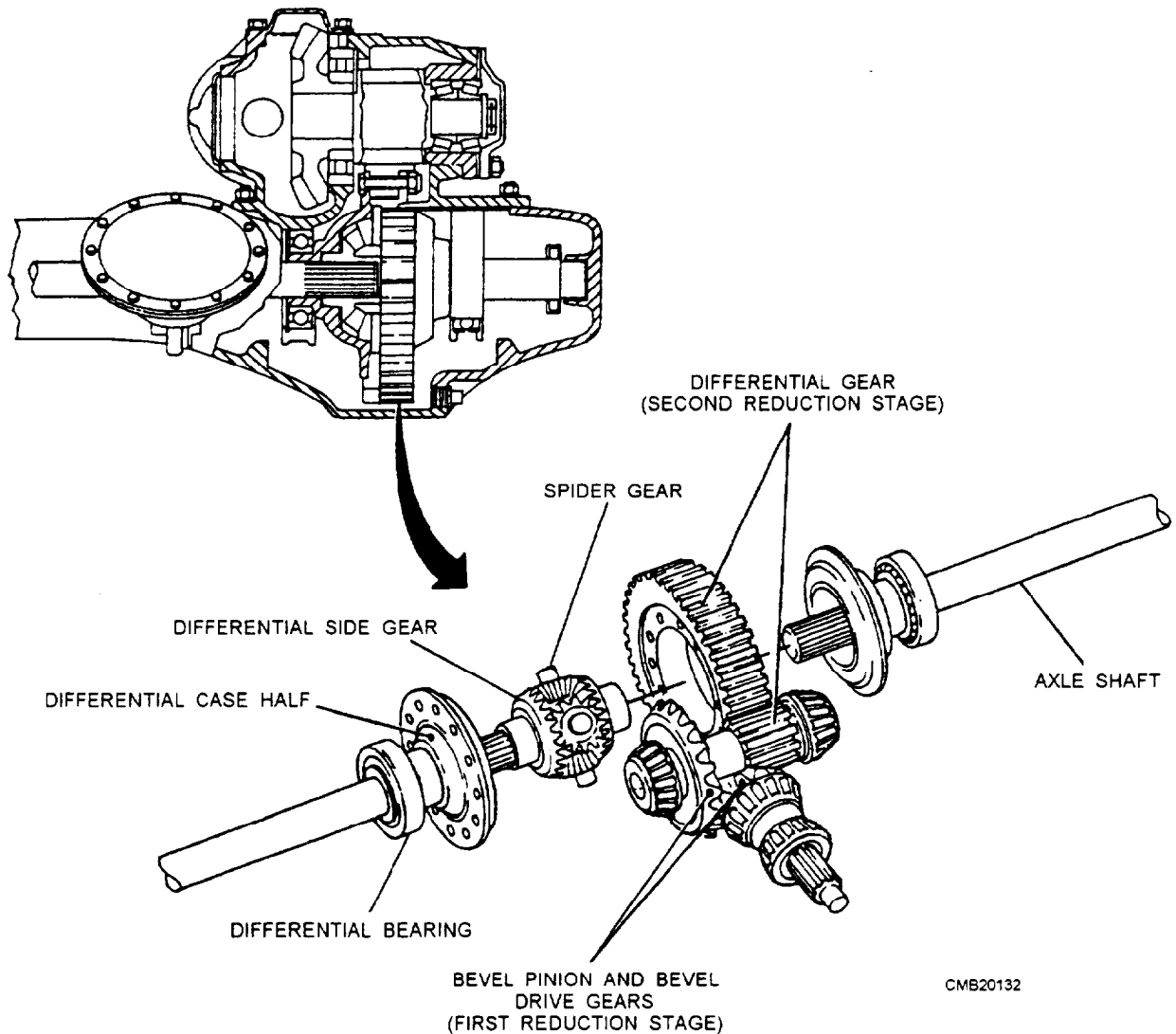

Figure 5-14.—Double-reduction final drive.

final drive with provisions for two speeds to be incorporated.

### **Two-Speed Final Drive**

The two-speed or dual-ratio final drive is used to supplement the gearing of the other drive train components and is used in vehicles with a single drive axle (fig. 5-15). The operator can select the range or speed of this axle with a button on the shifting lever of the transmission or by a lever through linkage.

The two-speed final drive doubles the number of gear ratios available for driving the vehicle under various load and road conditions. For example, a vehicle with a two-speed unit and a five-speed transmission, ten different forward speeds are available. This unit provides a gear ratio high enough to permit pulling a heavy load up steep grades and a low ratio to permit the vehicle to run at high speeds with a light load or no load.

The conventional spiral bevel pinion and ring gear drives the two-speed unit, but a planetary gear train is placed between the differential drive ring gear and the differential case. The internal gear of the planetary gear train is bolted rigidly to the bevel drive gear. A ring on which the planetary gears are pivoted is bolted to the differential case. A member, consisting of the sun gear and a dog clutch, slides on one of the axle shafts and is controlled through a button or lever accessible to the operator.

When in high range, the sun gear meshes with the internal teeth on the ring carrying the planetary gears and disengages the dog clutch from the left bearing adjusting ring, which is rigidly held in the differential carrier. In this position, the planetary gear train is locked together. There is no relative motion between the differential case and the gears in the planetary drive train. The differential case is driven directly by the differential ring gear, the same as in the conventional single fixed gear final drive.

When shifted into low range, the sun gear is slid out of mesh with the ring carrying the planetary gears. The dog clutch makes a rigid connection with the left bearing adjusting ring. Because the sun gear is integral with the dog clutch, it is also locked to the bearing adjusting rings and remains stationary. The internal gear rotates the planetary gears around the stationary sun gear, and the differential case is driven by the ring on which the planetary gears are pivoted. This action produces the gear reduction, or low speed, of the axle.

## **DIFFERENTIAL ACTION**

The rear wheels of a vehicle do not always turn at the same speed. When the vehicle is turning or when tire diameters differ slightly, the rear wheels must rotate at different speeds.

If there were a solid connection between each axle and the differential case, the tires would tend to slide, squeal, and wear whenever the operator turned the steering wheel of the vehicle. A differential is designed to prevent this problem (fig. 5-16).

### **Driving Straight Ahead**

When a vehicle is driving straight ahead, the ring gear, the differential case, the differential pinion gears, and the differential side gears turn as a unit. The two differential pinion gears do NOT rotate on the pinion shaft, because they exert equal force on the side gears. As a result, the side gears turn at the same speed as the ring gear, causing both rear wheels to turn at the same speed.

### **Turning Corners**

When the vehicle begins to round a curve, the differential pinion gears rotate on the pinion shaft. This occurs because the pinion gears must walk around the slower turning differential side gear. Therefore, the pinion gears carry additional rotary motion to the faster turning outer wheel on the turn.

Differential speed is considered to be 100 percent. The rotating action of the pinion gears carries 90 percent of this speed to the slower moving inner wheel and sends 110 percent of the speed to the faster rotating outer wheel. This action allows the vehicle to make the turn without sliding or squealing the wheels.

## **LIMITED SLIP DIFFERENTIALS**

The conventional differential delivers the same amount of torque to each rear wheel when both wheels have equal traction. When one wheel has less traction than the other, for example, when one wheel slips on ice, the other wheel cannot deliver torque. All turning effort goes to the slipping wheel. To provide good even traction even though one wheel is slipping, a limited slip differential is used in many vehicles. It is very similar to the standard unit but has some means of preventing wheel spin and loss of traction. The standard differential delivers maximum torque to the wheel with minimum traction. The limited slip differential delivers maximum torque to the wheel with maximum traction. Other names for a limited slip

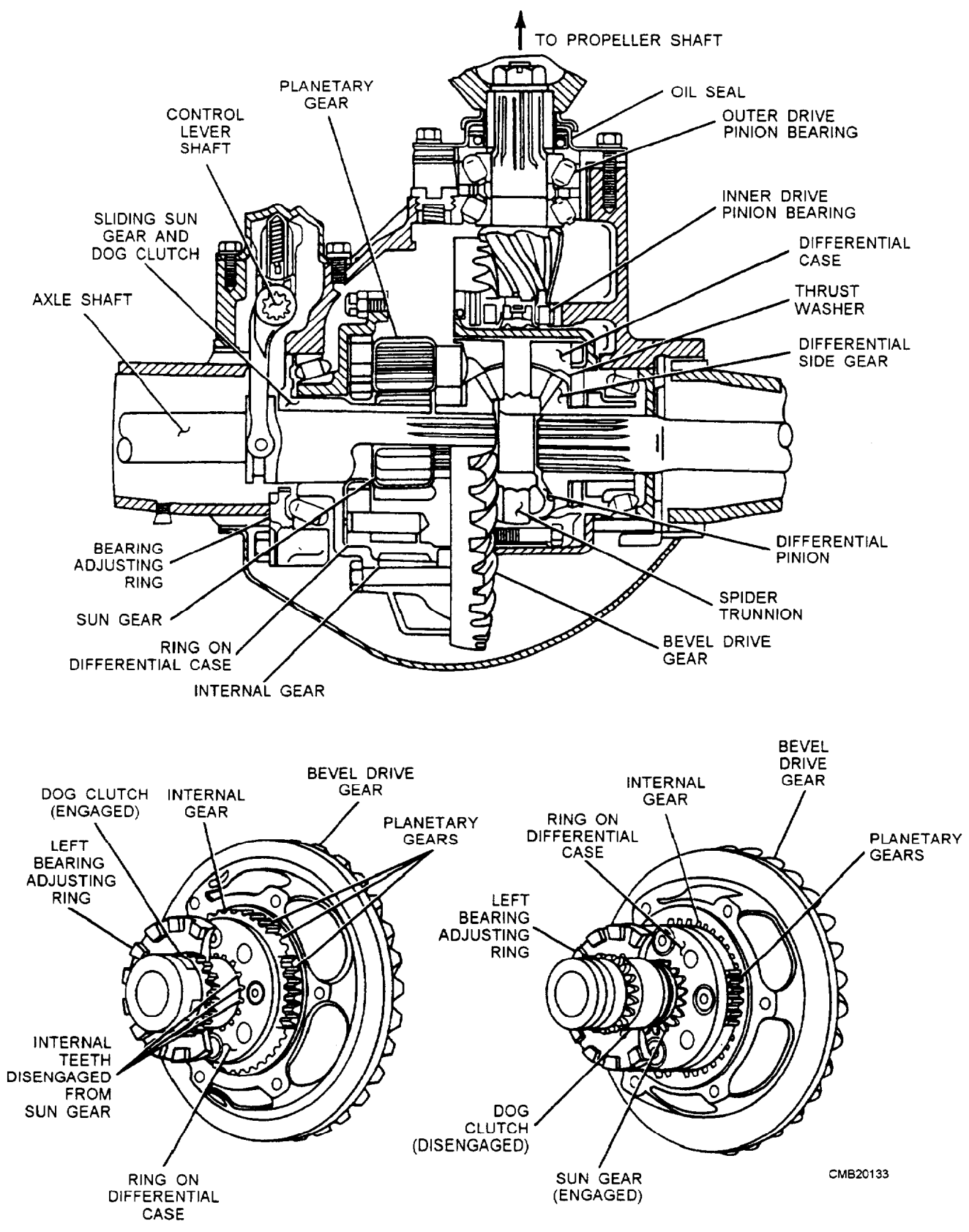

CMB20133

Figure 5-15.—Two speed final drive.

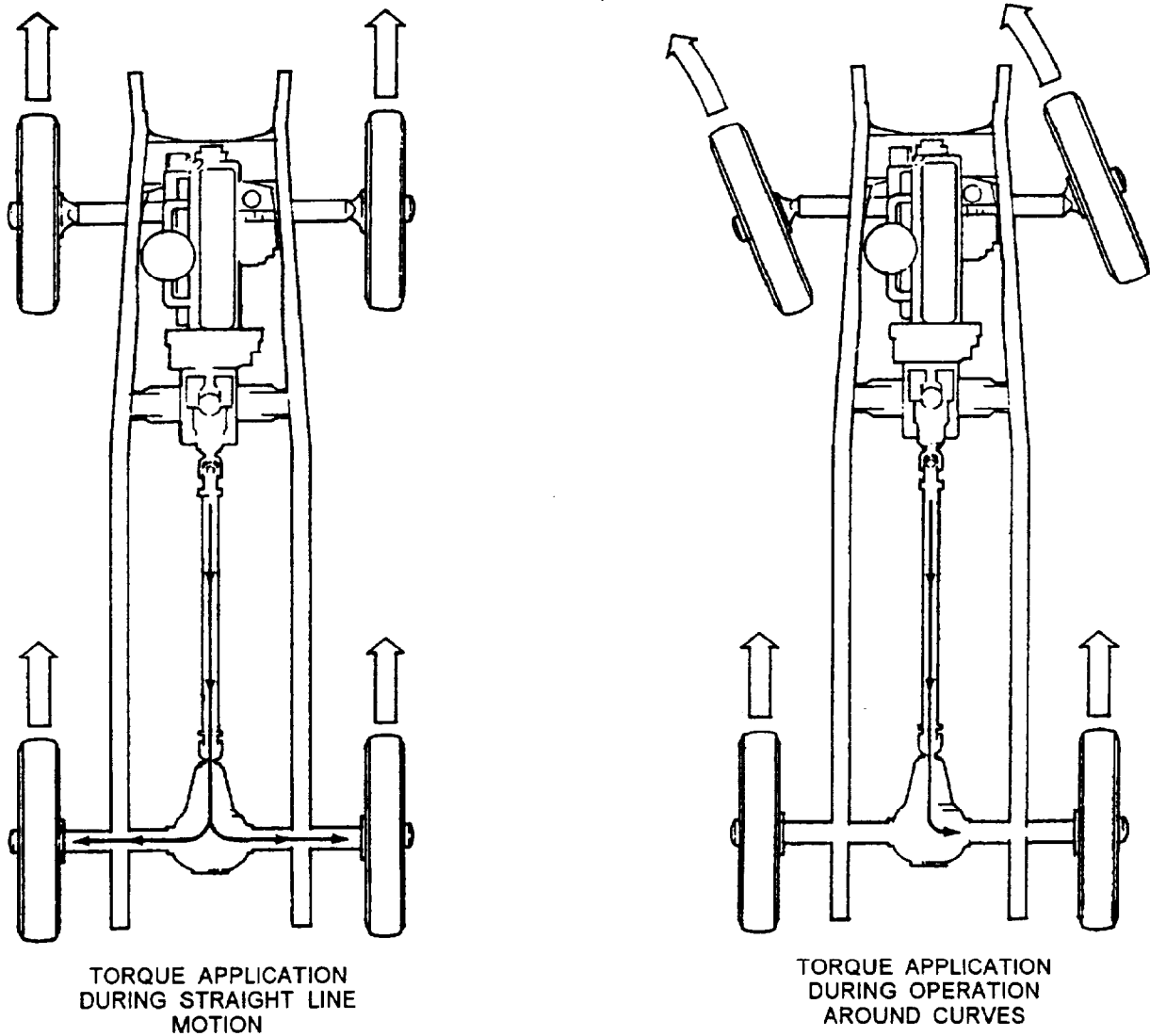

CMB20134

Figure 5-16.—Differential operation.

differential are posi-traction, sure-grip, equal-lock, and no-spin.

**Clutch Pack Limited Slip Differential**

The clutch pack limited slip differential (fig. 5-17) uses a set of friction discs and steel plates to lock the axles together whenever one drive wheel experiences uncontrolled slippage. The friction discs are sandwiched between the steel plates inside the differential case. The friction disc is splined and turns with the differential side gears. The steel plates turn with the differential case.

Springs (bellville springs, coil springs, or leaf springs) force the friction disc and steel plates together. As a result, both rear axles try to turn with the differential case.

Spring force and thrust action of the spider gears applies the clutch pack. Under high torque conditions, the rotation of the differential pinion gears PUSHES OUT on the axle side gears. The axle side gears then push on the clutch discs. This action helps lock the disc and keeps both wheels turning.

However, when driving normally, the vehicle can turn a corner without both wheels rotating at the same speed. As the vehicle turns a corner, the inner drive wheel must slow down. The unequal speed between the side gears causes the side gear pinions to walk around the side gears. This walking will cause the outer axle shaft to rotate faster than the differential case, allowing the pinion shaft on the side to slide down a V-shaped ramp. This action releases the outer clutches causing the clutch pack to slip when the vehicle is turning.



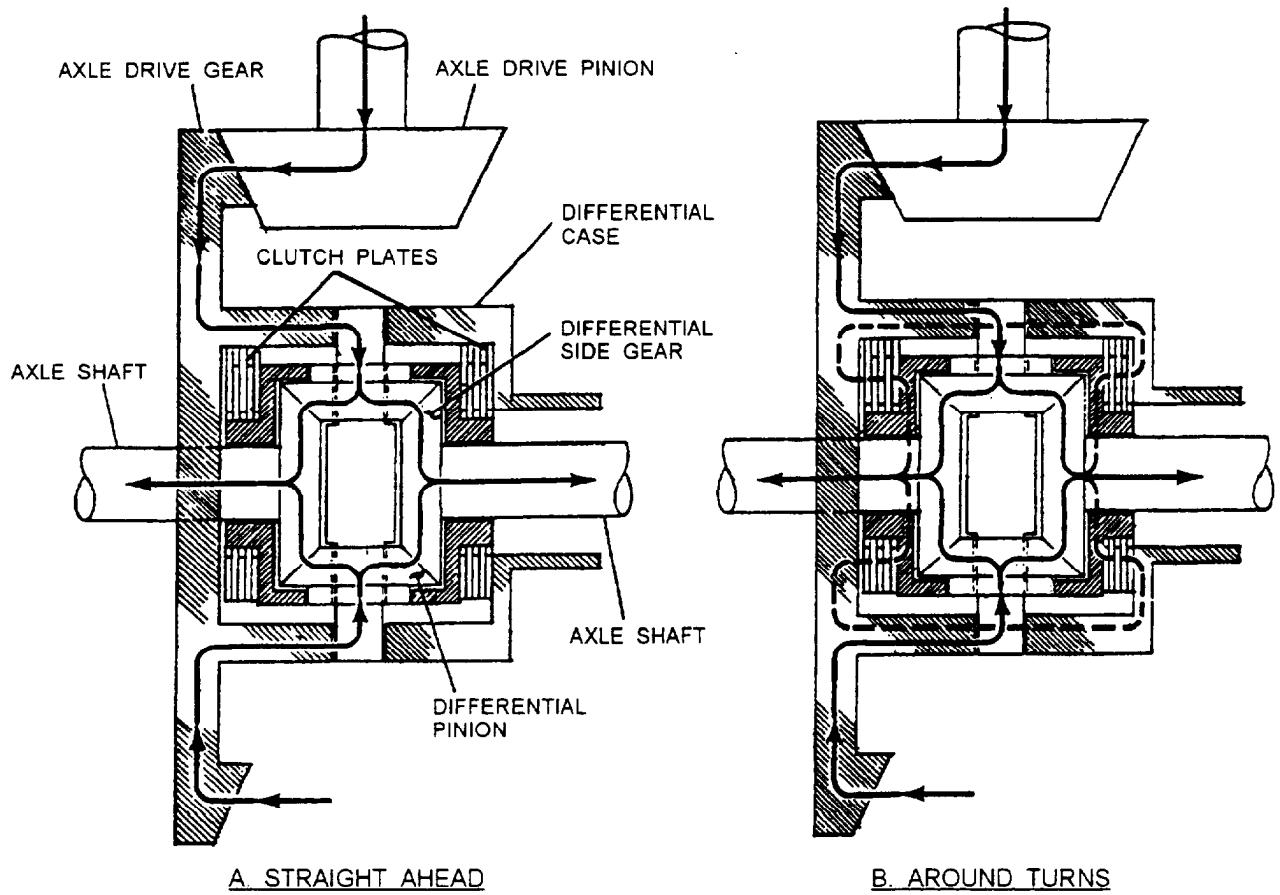
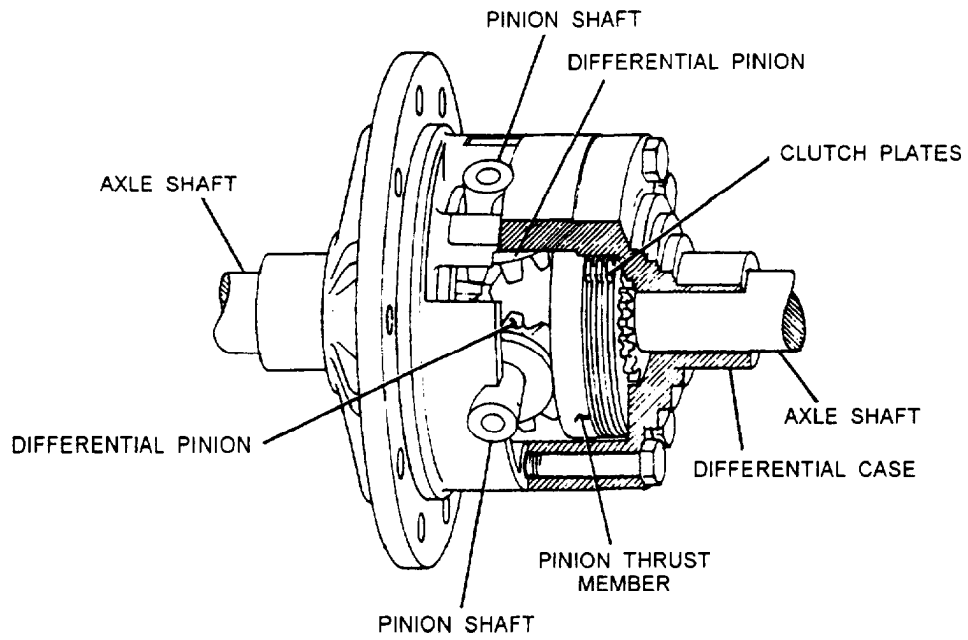

CMB20135

Figure 5-17.—Clutch pack limited slip differential.

## Cone Clutch Limited Slip Differential

A cone clutch limited slip differential uses the friction produced by cone-shaped axle gears to provide improved traction (fig. 5-18). These cones fit behind and are splined to the axle shafts. With the axles splined to the cones, the axles tend to rotate with the differential case. Coil springs are situated between the side gears to wedge the clutches into the differential case.

Under rapid acceleration or when one wheel loses traction, the differential pinion gears, as they drive the cones, push outward on the cone gears. This action increases friction between the cones and case, driving the wheels with even greater torque.

When a vehicle goes around a corner, the inner drive wheel must slow down. The unequal speed between the side gears will cause the side gear pinions to walk around the side gears. This walking action causes the outer axle shaft to rotate faster than the differential case. Because the cones have spiral grooves cut into their clutch surfaces, the inner cone will draw itself into the case and lock tight and the outer cone clutch will back itself out of the case. This action allows the outer drive axle to free wheel. The

end result is the majority of the engine torque is sent to the inner drive wheel.

## DIFFERENTIAL SERVICE AND MAINTENANCE

Differentials in a properly operated vehicle seldom cause any maintenance problems. By maintaining the proper lubrication level and occasionally changing a seal or gasket, the assembly will normally last as long as the vehicle.

The first hint of existing trouble is generally an unusual noise in the axle housing. To diagnose the trouble properly, you must determine the source of the noise and under what operating conditions the noise is most pronounced. Defective universal joints, rough wheel bearings, or tire noises may be improperly diagnosed by an inexperienced mechanic as differential trouble.

Some clue may be gained as to the cause of trouble by noting whether the noise is a growl, hum, or knock; whether it is heard when the vehicle is operating on a straight road, or on turns only; and whether the noise is most noticeable when the engine is driving the vehicle or when it is coasting with the vehicle driving the engine.

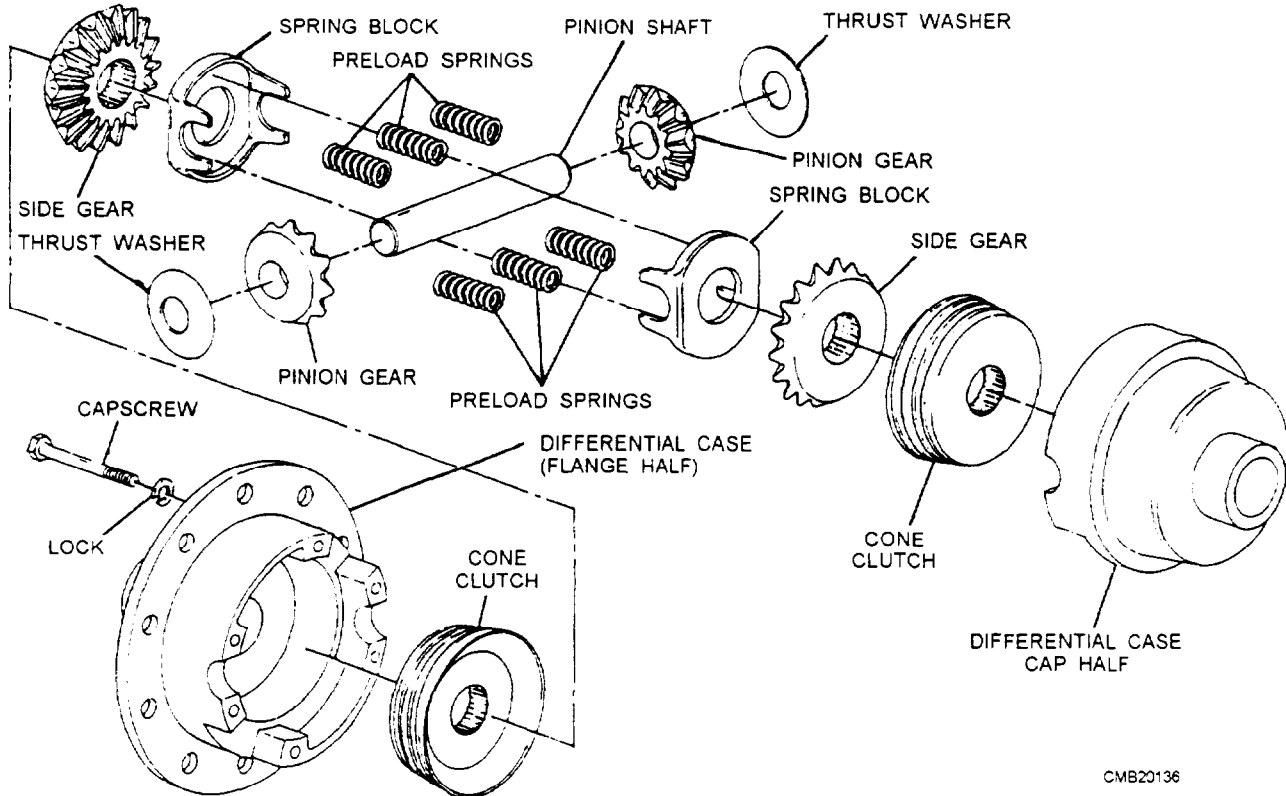

Figure 5-18.—Cone clutch limited slip differential.

A humming noise in the differential generally means the ring gear or pinion needs an adjustment. An improperly adjusted ring gear or pinion prevents normal tooth contact between the gears and therefore produces rapid tooth wear. If the trouble is not corrected immediately, the humming noise will gradually take on a growling sound, and the ring and pinion will probably have to be replaced.

It is very easy to mistake tire noise for differential noise. Tire noise will vary according to the type of pavement the vehicle is being operated on, while differential noise will not. To confirm a doubt as to whether the noise is caused by tire or differential, drive the vehicle over various pavement surfaces. If the noise is present in the differential only when the vehicle is rounding a corner, the trouble is likely to be in the differential case.

If the backlash (clearance) between the ring and pinion is too great, a CLUNKING sound is produced by the gears. For example, when an automatic transmission is shifted into drive, the abrupt rotation of the drive shaft can bring the gears together with a loud thump.

The ring and pinion gears can become worn, scored, out of adjustment, or damaged. The problems can result from prolonged service, fatigue, and from lack of lubricant. You need to inspect the differential to determine whether adjustment or part replacement is required.

A differential identification (ID) number is provided to show the exact type of differential for ordering parts and looking up specifications. The number may be on a tag under one of the carrier or inspection cover bolts; it also may be stamped on the housing or carrier. Use the ID number to find the axle type, axle ratio, make of the unit, and other information located in the service manual.

### **Differential Lubricant Service**

Many vehicle manufacturers recommend that the differential fluid be checked and replaced at specific intervals. To check the fluid level in a differential, remove the filler plug, which is located either in the front or rear of the assembly. The lubricant should be even with the fill hole when hot and slightly below the hole when cold.

When the manufacturer recommends that the differential fluid be replaced, remove the drain plug located on the bottom of the differential housing. Some

differentials require the removal of the inspection cover to drain the lubricant. With all the fluid drained, replace the drain plug or inspection cover and refill with the proper lubricant.

### **NOTE**

Always install the correct type of differential lubricant. Limited slip differentials often require a special type of lubricant for the friction clutches.

### **Differential Removal, Disassembly, and Reassembly**

Procedures for removal, disassembly, and reassembly vary depending on the type of differential, make, and model. Always refer to the manufacturer's service manual. However, there are several procedures that relate to almost any type of differential.

To remove a separate carrier differential, perform the following:

- Remove the drive shaft.
- Place a drain pan under the differential. Remove the drain plug and drain the lubricant.
- Unbolt the nuts around the outside of the carrier.
- Force the differential carrier away from the housing.

### **CAUTION**

A differential can be surprisingly heavy. Grasp it securely during removal. If the differential is dropped, painful injuries can occur.

To remove an integral differential, perform the following:

- Remove the drive shaft.
- Place a drain pan under the differential. Remove the inspection cover and drain the lubricant.
- With the cover off, inspect and MARK the individual components as they are removed.

The procedure for repairing a differential will vary with the particular unit. Always refer to the service manual. When using a service to repair a differential, remember the following:

- Check for markings before disassembly. The carrier caps, adjustment nuts, shims, ring and

pinion, spider gears, and pinion yoke or flange should be installed exactly as they were removed. If needed, punch mark, label, or scribe these components so they can be reassembled properly.

- Clean all parts carefully and inspect them closely for damage.
- Rotate the pinion and case bearing by hand while checking for roughness. Inspect each bearing and race. Replace the bearing and race as a set if faulty.
- If the pinion gear has a collapsible spacer (device for preloading the pinion bearings), always replace it.
- To avoid seal damage, use a seal driver. Coat the outside of the seal with a nonhardening sealer. Lubricate the inside of the seal using the proper grade of differential fluid. Make sure the seal lip faces the inside of the differential.
- When tightening the pinion yoke nut, clamp the yoke in a vise or use a special holding bar.
- Replace the ring and pinion gears as a set. Mesh and align the gear timing marks (painted lines or other markings) on the ring and pinion gears.

This will match the proper teeth that have been lapped together at the factory.

- Torque all fasteners to specifications. Refer to the service manual for torque values.
- Use new gaskets and/or approved sealer.
- Align all markings during reassembly. If you install the carrier caps backwards, for example, the caps can crush and damage the bearing and races. The differential could fail soon after it is returned to service.
- Use the service manual for detailed directions. Differential designs and repair procedures vary. Special tools and methods are frequently required.

### Differential Measurements and Adjustments

Several measurements and adjustments are made when assembling a differential. When “setting up” (measuring and adjusting) a differential, correct bearing preloads and gear clearances are extremely critical. The most important differential measurements and adjustments (fig. 5-19) include the following:

1. Pinion gear depth

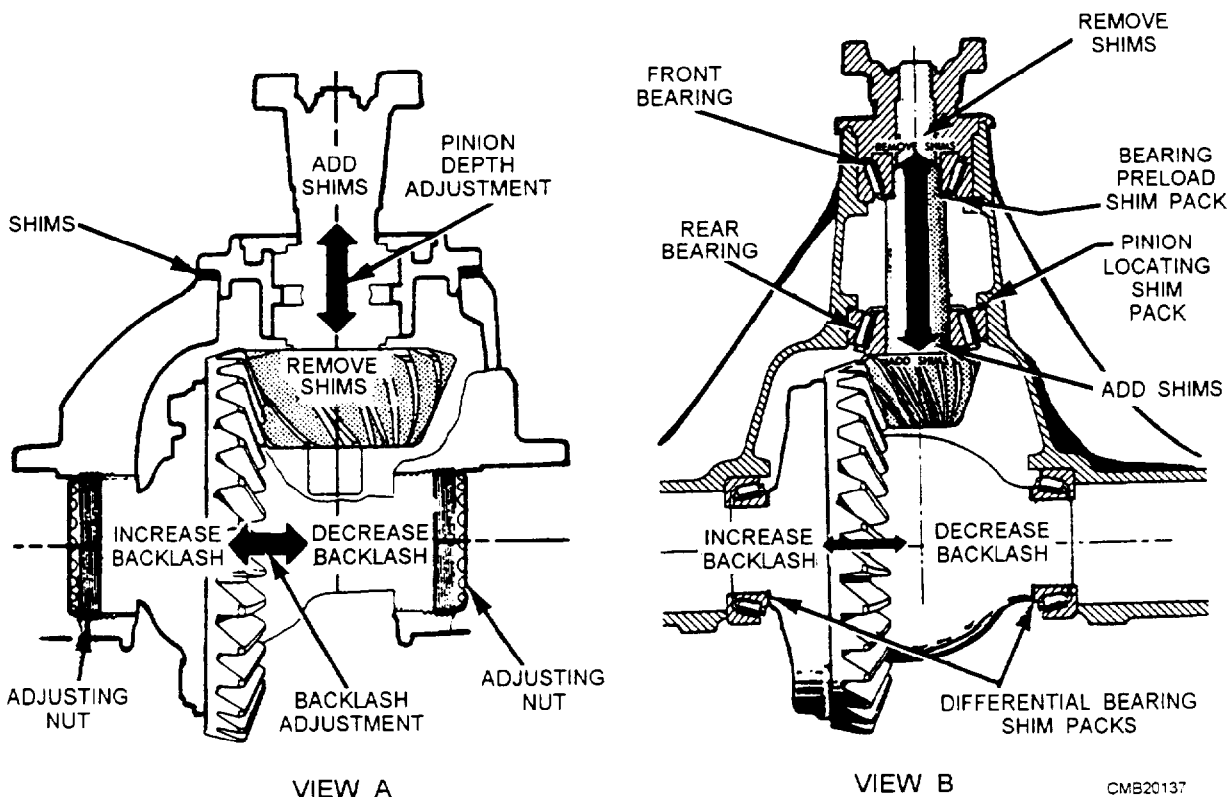

Figure 5-19.—Pinion and ring gear adjustments.

2. Pinion bearing preload
3. Case bearing preload
4. Ring gear runout
5. Ring and pinion backlash
6. Ring and pinion contact pattern

**PINION GEAR DEPTH.**—The pinion gear depth refers to the distance the pinion gear extends into the carrier. Pinion depth affects where the pinion gear teeth mesh with the ring gear teeth. Pinion gear depth is commonly adjusted by varying shim thickness on the pinion gear and bearing assembly.

**PINION BEARING PRELOAD.**—The pinion bearing preload is frequently adjusted by torquing the pinion nut to compress a collapsible spacer. The more the pinion nut is torqued, the more the spacer will compress to increase the preload or tightness of the bearings.

With a collapsible spacer, only tighten the pinion nut in small increments. Then measure the pinion preload by turning the pinion nut with an inch-pound torque wrench.

When a solid spacer and pinion nut are used, shims control pinion bearing preload. The pinion nut is torqued to a specific value found in the service manual.

To set pinion bearing preload, use a holding tool to keep the pinion gear stationary. Then a breaker bar or torque wrench can be used to tighten the pinion nut.

**CASE BEARING PRELOAD.**—The case bearing preload is the amount of force pushing the differential case bearings together. As with pinion bearing preload, it is critical.

If preload is too low (bearings too loose), differential case movement and ring and pinion gear noise can result. If preload is too high (bearings too tight), bearing overheating and failure can result.

When adjusting nuts are used, the nuts are typically tightened until all of the play is out of the bearings. Then each nut is tightened a specific portion of a turn to preload the bearings. This is done when adjusting backlash.

When shims are used, a feeler gauge is used to check side clearance between the case bearing and the carrier. This action will let you calculate the correct shim thickness to preload the case bearings. Refer to the service manual for special equipment and procedures.

**RING GEAR RUNOUT.**—The ring gear runout is the amount of wobble or side-to-side movement produced when the ring gear is rotated. Ring gear runout must not be beyond the manufacturer's specifications.

To measure ring gear runout, mount a dial indicator against the back of the ring gear (fig. 5-20). The indicator stem should be perpendicular to the ring gear surface. Then turn the ring gear and note the indicator reading. If the ring gear is within specifications, locate a position on the ring gear that indicates ONE HALF of the maximum runout on the gauge. Mark the gear at that point. Then rotate the ring gear until the teeth on the opposite side of the gear from the mark are in mesh with the pinion gear.

If ring gear runout is excessive, check the ring gear mounting and differential case runout. If not a mounting problem, replace either the ring gear and pinion or the case as needed.

**RING AND PINION BACKLASH.**—The ring and pinion backlash refers to the amount of space between the meshing teeth of the gears. Backlash is needed to allow for heat expansion

As the gears operate, they produce friction and heat. This makes the gears expand, reducing the clearance between the meshing teeth of the gears. Without backlash, the ring and pinion teeth can jam into each other and fail in a very short period of time. However, too much ring and pinion backlash can cause gear noise (whirring, roaring, or clunking).

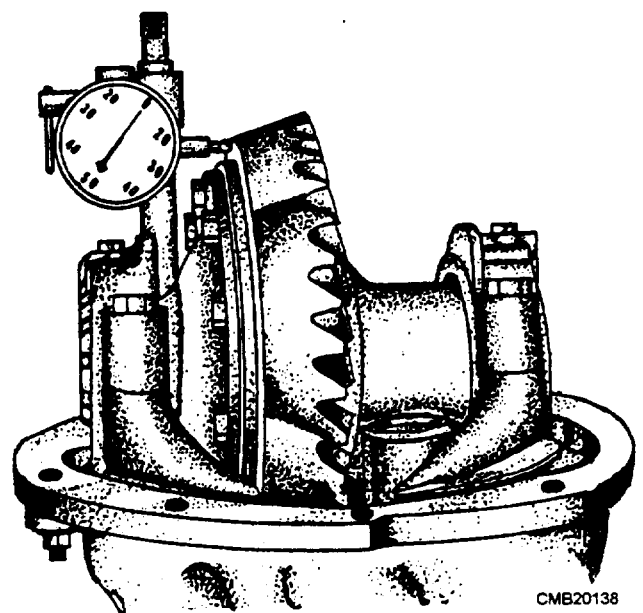

Figure 5-20.—Measuring ring gear runout.

To measure ring and pinion backlash, position a dial indicator stem on one of the ring gear teeth. Then, while holding the pinion gear STATIONARY, wiggle the ring gear back and forth. Indicator needle movement will equal gear backlash. Compare your measurements to the manufacturer's specifications and adjust as needed.

Backlash adjustment can be made by adjusting nuts or by moving shims from one side to the other. To increase backlash, move the ring gear away from the pinion gear. To decrease backlash, move the ring gear towards the pinion gear.

**RING AND PINION TOOTH CONTACT PATTERN.**—The ring and pinion tooth contact pattern is used to double-check ring and pinion adjustment.

To check the accuracy of your adjustments, coat the ring gear teeth with a thin coat of red lead, white grease, hydrated ferric oxide (yellow oxide or iron), or Prussian blue. Turn the ring gear one way and then the other to rub the teeth together, producing a contact pattern on the teeth. Carefully note the contact pattern that shows up on the teeth where the substance used has been wiped off.

A good contact pattern is one located in the center of the gear teeth (fig. 5-21). Figure 5-21 shows several ring and pinion gear contact patterns. Study each and note the suggested correction for the faulty contact.

Note the names of the areas on the ring gear. These include the following:

- TOE (narrow part of the gear tooth)
- HEEL (wide part of the gear tooth)
- DRIVE SIDE (convex side of the gear tooth)
- COAST SIDE (concave side of the gear tooth)

When used gears are adjusted properly, the contact pattern will vary from that of new gears. The important thing to keep in mind with used gears is that the pattern should be closer to the toe than the heel of the tooth, as shown in figure 5-21. Notice that the ideal tooth pattern on new teeth is uniform on both sides, whereas the used gear indicates considerably more contact on the coasting side.

Once you have obtained the proper adjustment on the ring and pinion, bolt the carrier housing in place. Make sure you use a new gasket. Tighten the bolts according to the manufacturer's specifications to prevent them from working loose. Reinstall the axle shafts and new gaskets. Reconnect the drive shaft and fill the axle housing with the proper lubricant.

### REVIEW 2 QUESTIONS

Q1. The \_\_\_\_\_ must be capable of providing torque to both axles when turning corners.

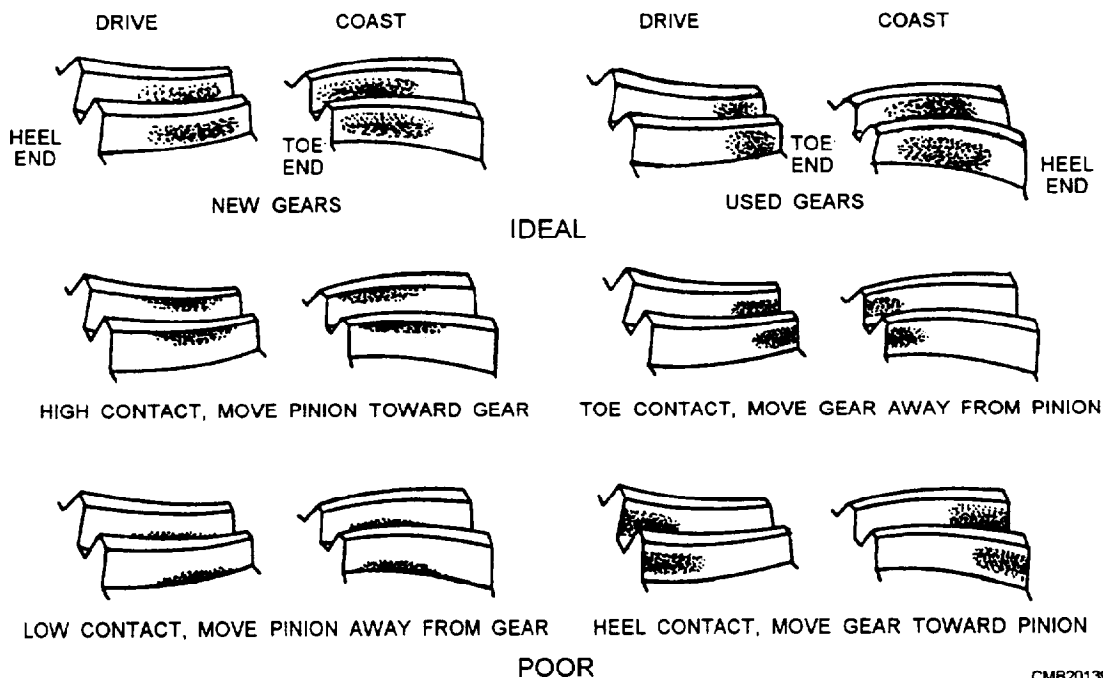

Figure 5-21.—Tooth contact patterns.

CMB20139

- Q2. An integral carrier is constructed as part of the axle housing. (T/F)
- Q3. Rear axle ratio is determined by comparing the number of teeth on the \_\_\_\_\_ to the number of teeth on the \_\_\_\_\_.
- Q4. Excess ring and pinion backlash can cause a "clunking" sound when an automatic transmission is placed in drive. True/False
- Q5. \_\_\_\_\_ often require a lubricant that is compatible with friction clutches.
- Q6. Ring and pinion preload is a common differential adjustment. (T/F)

### DRIVE AXLES

**Learning Objective:** Identify the parts of the rear drive axle and front drive axle. List the function of the rear axle. Compare the different types of axles. Describe the procedures for replacing axle bearings and seals.

Axles are classified as either LIVE or DEAD. The live axle is used to transmit power. The dead axle only serves as a support for part of the vehicle while providing a mounting for the wheel assembly. Many commercial trucks and truck-tractors have dead axles on the front, whereas practically all passenger vehicles use independent front-wheel suspensions and have no front axles.

The shaft in a live axle assembly may or may not actually support part of the weight of a vehicle, but it does drive the wheels connected to it. A live axle is involved with steering when it is a front drive axle. Some live rear axles are also designed to steer. The rear axle of conventional passenger vehicles is a live axle, while in a four-wheel drive vehicle both front and rear axles are live. In some six-wheel vehicles, all three axles are live axles.

### AXLE HOUSING

The axle housing may be of the one-piece or split (banjo) type construction. The former, known as the banjo type because of its appearance, is far more common (fig. 5-22). Notice that openings, both front and rear, are provided in the center housing. The front opening is closed by the differential carrier, while the rear is closed by a spherical cover plate.

Since the assembly must carry the weight of the vehicle, the axle housing in heavy trucks and tractors is a heavy cast unit. In light-duty trucks it may be a combination of cast and steel tube; in general, the center or differential and final drive case is a cast and machined unit, whereas the axle housings themselves may be welded or extruded steel tubing.

Items, such as brake backing plates, mounting flanges, spring mounting plates, and accessory units, may be riveted, welded, or cast into the axle housing. Inspection covers are often provided through which

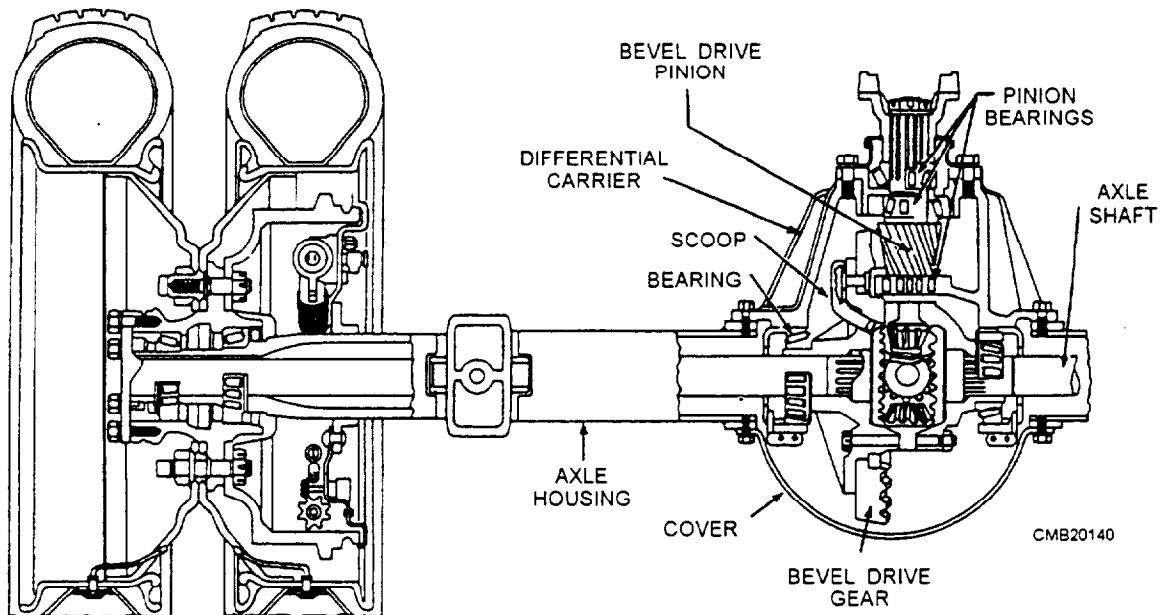

Figure 5-22.—Axle assembly.

the internal parts can be inspected, removed, and installed. Lubricant filler plugs are usually incorporated in the housing inspection cover.

To prevent pressure buildup when the axle becomes warm, a breather vent or valve is provided atop the housing. Without this valve, the resulting pressure could force the axle lubricant past the rear wheel oil seals and damage the brake linings. The valve is constructed so air may pass in or out of the axle housing; however, dirt and moisture are kept out.

## REAR DRIVE AXLE

The rear drive axle connects the differential side gears to the drive wheels. The axle may or may not support the weight of the vehicle. Rear axles are normally induction hardened for increased strength. There are several types of rear axle designs: semifloating, three-quarter floating, and full floating. However the semi- and full-floating types are the most common. Most automobiles use the semifloating type, whereas four-wheel drive vehicles and trucks use full floating axles.

### Semifloating Axle

The semifloating axle is used in passenger vehicles and light trucks. In vehicles equipped with this type of axle, the shaft, as well as the housing, supports the weight of the vehicle. The inner end of the axle is carried by the side gears in the differential housing. This relieves the axle shafts of the weight of the differential and the stresses caused by its operation that are taken by the axle housing. The inner ends of the axle transmit only turning effort, or torque, and are not acted upon by any other force.

The outer end is carried by a bearing located between the shaft and the housing. A tapered roller of ball-type bearing transfers the load from the shaft to the housing. The axle shafts take the stresses caused by turning, skidding, or wobbling of the wheels.

The axle shafts (fig. 5-23) are flanged or tapered on the ends. When the tapered axle is used, the brake drum and hub are pressed onto the shafts, using keys to prevent the assemblies from turning on the shafts. In some cases, the outer ends of the shafts may have serrations or splines to correspond with those on the drum and hub assembly. Should the axle break with this type of axle assembly, the wheel can separate from the vehicle.

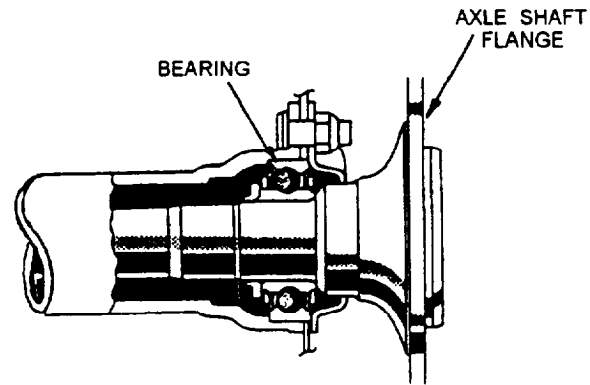

BALL BEARINGS AND FLANGE SHAFT

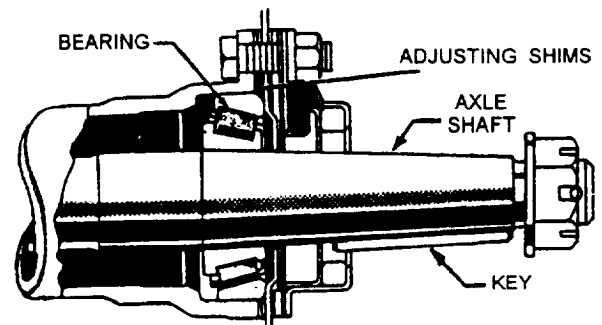

TAPERED ROLLER BEARINGS AND SHAFT

CMB20141

Figure 5-23.—Semifloating axle installation.

### Full-Floating Axle

The full-floating axle (fig. 5-24) is used in many heavy-duty trucks. The drive wheel is carried on the outer end of the axle housing by a pair of tapered roller bearings. The bearings are located outside the axle housing. In this way, the axle housings take the full weight of the vehicle and absorb all stresses or end thrust caused by turning, skidding, and pulling. Only the axle shaft transmits torque from the differential.

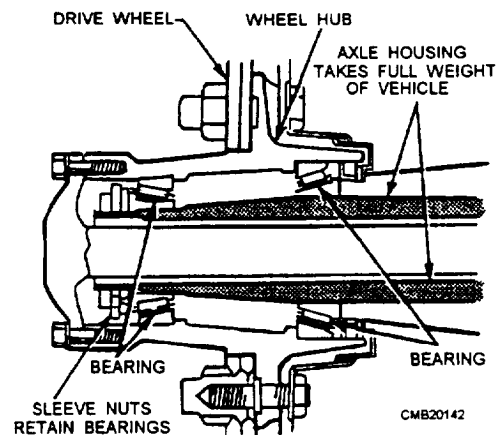

CMB20142

Figure 5-24.—Full-floating axle shaft.



The axle shaft is connected to the drive wheel through a bolted flange. This allows the axle shaft to be removed for servicing without removing the wheel.

## FRONT DRIVE AXLE

A front drive axle (fig. 5-25) is very similar to a rear drive axle; however, provisions must be made for steering the front wheels. Power is transmitted from the transfer case to the front axle by a drive shaft. The differential housing may be set off center in the axle housing to permit the drive shaft to pass beside the

engine oil pan and maintain sufficient road clearance without excessive height at the front end of the vehicle.

Since the front wheels must turn on the spindle arm pivots, they must be driven by the axle shaft through universal joints, which are located on the outer ends of the axles. The universal joints allow the front wheels and hubs to swivel while still transferring driving power to the hubs and wheels.

The cross and roller joint shown in figure 5-25 is similar to conventional U-joints used on the rear drive shaft, and, in some cases, they are interchangeable.

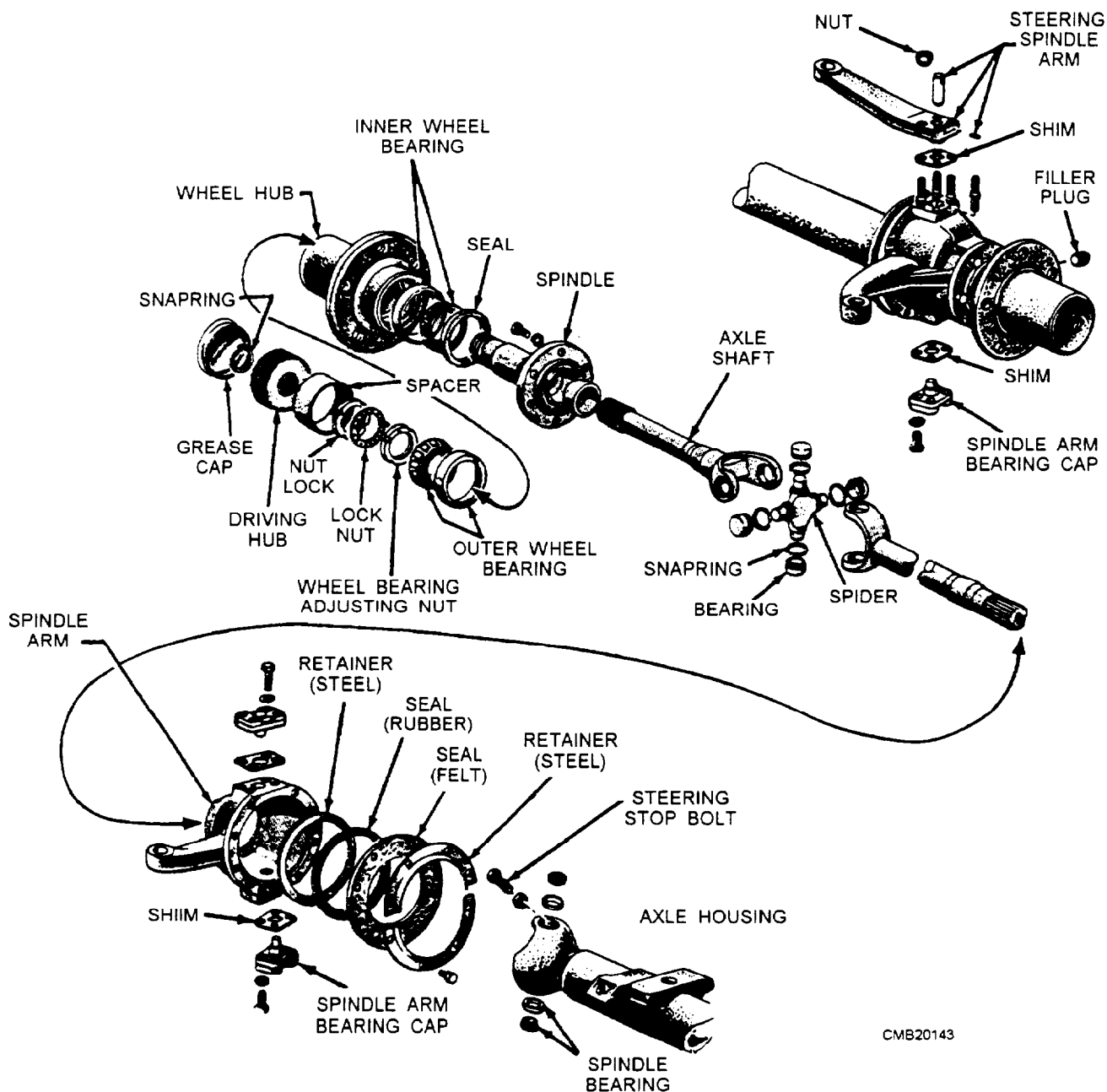

Figure 5-25.—Front drive axle.

This type of U-joint is limited to use in light-duty, vehicles. Other types of universal joints are used in the axles of heavy-duty vehicles. The types you will encounter in military designed vehicles are the Rzeppa and Bendix-Weiss constant velocity joints (fig. 5-26).

The front drive axle of a four-wheel drive axle requires locking hubs. Locking hubs transfer power from the driving axles to the driving wheels on a four-wheel drive vehicle. There are three basic types of locking hubs, which are as follows:

- **MANUAL LOCKING HUB**—requires the operator to turn a latch on the hub to lock the hub for four-wheel drive action.
- **AUTOMATIC LOCKING HUB**—hub locks the front wheels to the axles when the operator shifts into four-wheel drive.
- **FULL TIME HUB**—front hubs are always locked and drive the front wheels.

Manual and automatic locking hubs are the most common. Used with part-time, four-wheel drive, they enable the drive line to be in two-wheel drive for use on dry pavement. The front wheels can turn without turning the front axles. This allows for increased fuel economy and reduces drive line wear.

### FRONT-WHEEL DRIVE (AXLES)

Front-wheel drive axles, also called axle shafts or front drive shafts, transfer power from the transaxle differential to the hubs and wheel of a vehicle. Front-wheel drive axles turn much slower than a drive shaft for a rear-wheel drive vehicle. They turn about one third slower. They are connected directly to the drive wheels and do NOT have to act through the reduction of the axle ring gear and pinion gears.

Front-wheel drive axles typically consists of the following:

- **INNER STUB SHAFT**—the short shaft splined to the side gears in the differential and connected to the inner universal joint.
- **OUTER STUB SHAFT**—the short shaft connected to the outer universal joint and the front-wheel hub.
- **INTERCONNECTING SHAFT**—the center shaft that fits between the two universal joints.

Universal joints that connect the drive axle are called CV joints. The outer CV joint is a **FIXED** (nonsliding) ball and cage or Rzeppa-type joint that transfers rotating power from the axle shaft to the hub

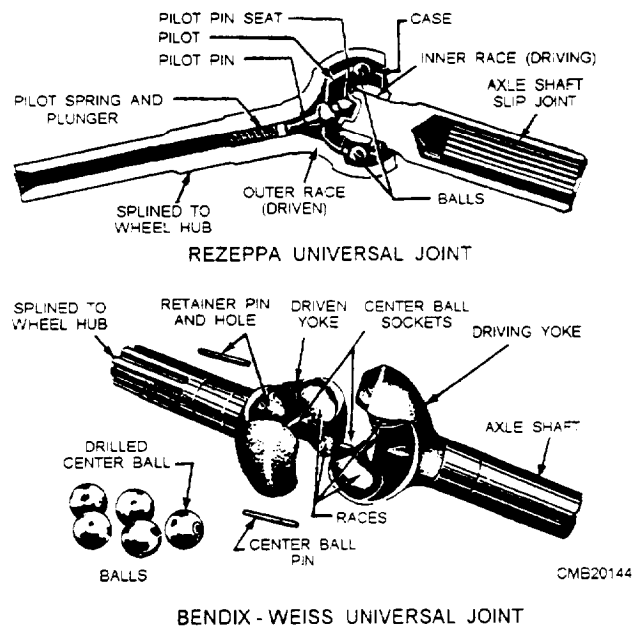

Figure 5-26.—Constant velocity universal joints.

assembly. The inner CV joint is called a **PLUNGING** (sliding) ball and housing or tripod-type joint that acts like a slip joint in a drive shaft for a rear-wheel drive vehicle.

The plunging action of the inner CV joint allows for a change in distance between the transaxle and the wheel hub. As the front wheels move up and down over bumps in the road, the length of the drive axle (inner joint) must change.

### REAR AXLE SERVICE

Rear axle service is needed when an axle bearing is noisy, when an axle is broken, bent, or damaged, or when an axle seal is leaking. The rear axles must be removed to allow removal and repair of the differential assembly.

#### Axle Bearing Service

Worn or damaged bearings in the carrier or on the axles produce a **CONSTANT** whirring or humming sound. These bearings, when bad, make about the same sound whether accelerating, decelerating, or coasting. When diagnosing and repairing bearing failures, do the following:

- Check the general condition of all parts during disassembly, not just the most badly worn or damaged parts.

- Compare the failure to any added information in the service manual and your knowledge of the components operation.
- Determine the cause of the part failure. This helps in assuring that the problems do NOT reoccur.
- Perform all repairs following the manufacturer's recommendations and specifications.

When an axle bearing is faulty, it must be removed from the axle or housing carefully and a new one installed. Depending on the type of axle configuration determines how the bearing is to be removed and replaced. Always refer to the manufacturer's service manual for instructions for the removal and installation of the bearing.

The procedures we will discuss are for a semifloating axle with the bearing and collar pressed on. With the axle removed from the vehicle, proceed as follows:

#### **NOTE**

Procedures for axle removal may be found in the service manual for the applicable vehicle.

1. Carefully cut off the collar with a grinder and a sharp chisel.
2. With the collar off, place the axle in a hydraulic press. The driving tool should be positioned so that it contacts the inner bearing race. Use the press to push the axle through the bearing.
3. To install the new bearing, slide the bearing onto the axle. Make sure that the bearing is facing the right direction. Some bearings have a chamfered edge on the inner bearing race, which must face the axle flange.
4. Applying force on the inner bearing race, press the bearing into place by pressing the axle back through the bearing. Then press the collar or retaining ring onto the axle.

#### **CAUTION**

Do NOT use a cutting torch to remove the collar and bearing. The heat will weaken and damage the axle.

#### **WARNING**

Wear eye and face protection when grinding or chiseling the collar from the axle. Small metal particles may fly into your eyes causing eye damage.

NEVER press on the outer race; bearing damage or explosion will result.

Wear face and eye protection when pressing a bearing on or off the axle shaft. The tremendous pressure used can cause the bearing to shatter and fly into your face with deadly force.

#### **CAUTION**

Do NOT attempt to press the bearing and collar on at the same time. Bearing and collar damage can result.

#### **Axle Seal Service**

Rear axle lubricant leaks can occur at numerous spots, such as the pinion gear seal, carrier or inspection cover gaskets, and at the two axle seals. The leak will show up as a darkened, oily, dirty area below the pinion gear, carrier, or on the inside of the wheel and brake assembly.

Always make sure that a possible axle seal leak is not a brake fluid leak. Touch and smell the wet area to determine the type of leak.

Anytime the axle is removed for service, it is wise to install a new axle seal. This action ensures that the seal between the axle and axle seal is tight. The axle seal is normally force-fitted in the end of the axle housing.

To remove a housing mounted seal, use a slide hammer puller equipped with a hooknose. Place the hook on the metal part of the seal. With an outward jerk on the puller slide, pop out the seal. If a slide hammer puller is not available, a large screwdriver will also work.

#### **CAUTION**

Be careful not to scratch the bearing bore in the axle housing.

## TRANSFER CASES

Make sure that you have the correct new seal. Its outside and inside diameters must be the same as the old seal. A seal part number is stamped on the outside of the seal. This number and the seal manufacturer's name will assist you when ordering a new seal.

Before installing the new seal, coat the outer diameter with a non-hardening sealer. Coat the inside of the seal with lubricant that is the same grade that is in the axle assembly. With the seal facing in the right direction (sealing lip towards inside of the housing), drive the seal squarely into place, using a seal-driving tool. Be careful not to bend the metal seal housing or a leak can result. Make sure the seal is fully seated.

### REVIEW 3 QUESTIONS

- Q1. *What component prevents pressure from building up inside the axle housing?*
- Q2. *What type of axle only transmits torque from the differential and carries no vehicle weight?*
- Q3. *What two types of CV joints are used on front-wheel drive vehicles?*
- Q4. *Worn and damaged axle bearings produce what type of sound(s)?*
- Q5. *What tool is used to remove a housing mounted seal?*

**Learning Objective:** Explain the operation of a transfer case. Explain basic service operations on a transfer case.

Transfer cases are used in off-road vehicles to divide engine torque between the front and rear driving axles. The transfer case also allows the front driving axle to be disengaged, which is necessary to prevent undue drive line component wear during highway use. Another purpose of the transfer case is to move the drive shaft for the front driving axle off to the side so that it can clear the engine. This arrangement is necessary to allow adequate ground clearance and to allow the body of the vehicle to remain at a practical height. Figure 5-27 shows a typical drive line arrangement with a transfer case.

### CONVENTIONAL TRANSFER CASE

A conventional transfer case is constructed similar to a transmission, in that it uses shift forks, splines, gears, shims, bearings, and other components found in manual and automatic transmissions. The transfer case has an outer case made of either cast iron or aluminum that is filled with a lubricant that cuts friction on all moving parts. Seals hold the lubricant in the case and prevent leakage from around the shafts and yokes. Shims are used to set up the proper clearances between the internal components and the case.

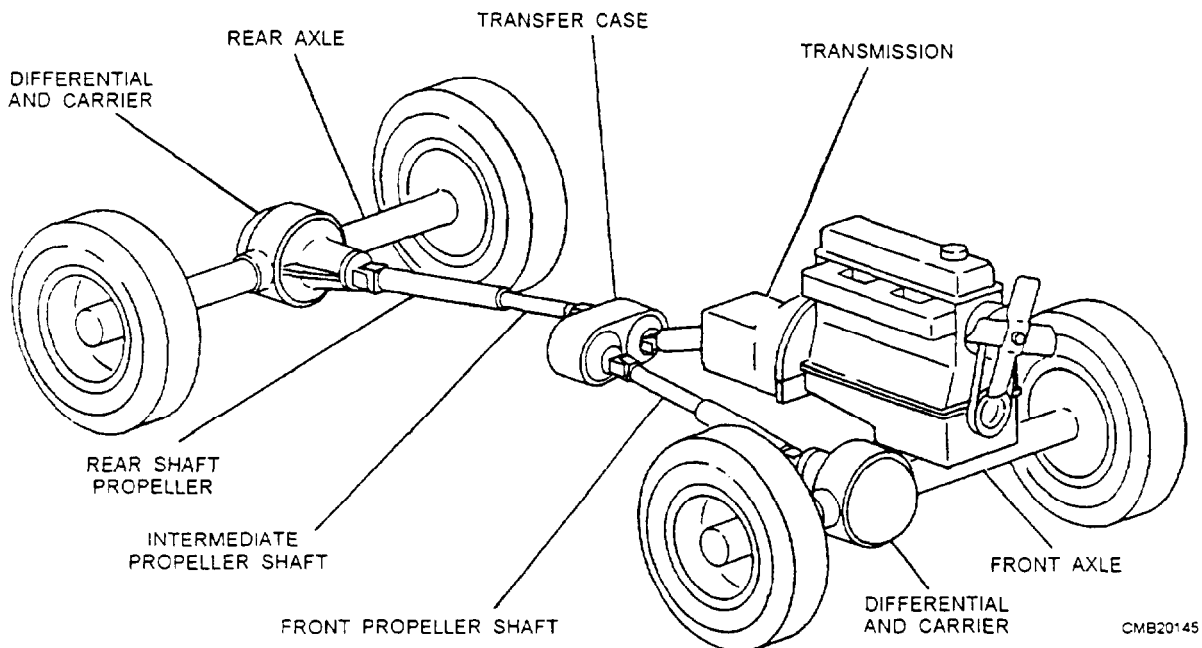

Figure 5-27.—Typical drive line arrangement with a transfer case.

Conventional transfer cases in heavier vehicles have two-speed positions and a de-clutching device for disconnecting the front-driving wheels. A cross section of a conventional two-speed transfer case is shown in figure 5-28. This type of transfer case is used for a six-wheel drive vehicle. Some light-duty vehicles use a chain to transmit torque to the front-driving axle (fig. 5-29).

The conventional transfer case provides a high and low final drive gear range in the same manner as an auxiliary transmission. In most cases, the shifting is accomplished through a sliding dog clutch, and shifting must be done while the vehicle is not moving. Typical operation of a conventional two-speed transfer case is as follows:

- **High Range** (fig. 5-30)—When driving the front and rear axles in the high range (1:1 gear ratio), the external teeth of the sliding gear

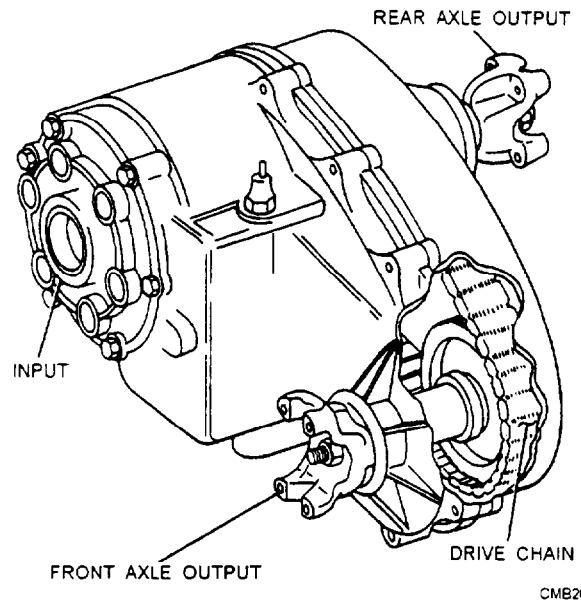
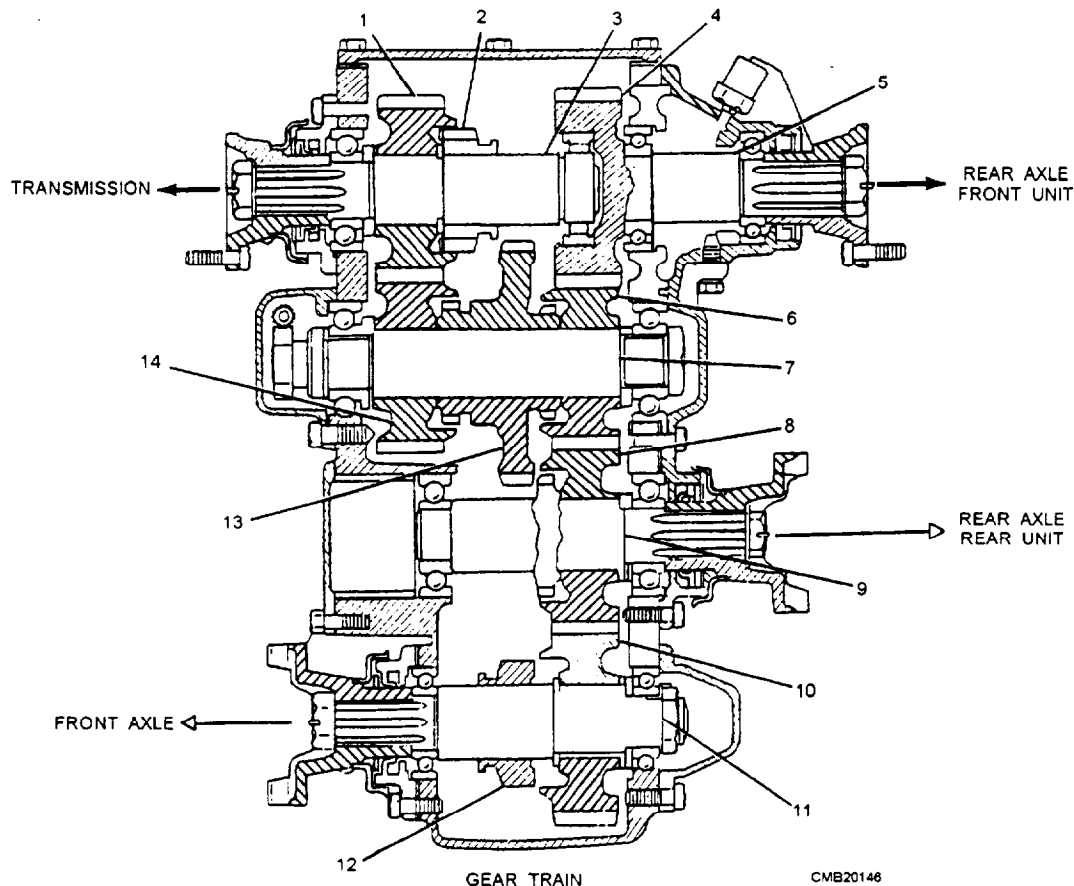

Figure 5-29.—Typical conventional transfer case using chain drive.



- |  |                                       |
|--|---------------------------------------|
| 1. MAINSHAFT CONSTANT MESH GEAR              | 8. DRIVE SHAFT CONSTANT MESH GEAR     |
| 2. MAINSHAFT SLIDING GEAR                    | 9. REAR AXLE (FRONT UNIT) DRIVE SHAFT |
| 3. MAINSHAFT                                 | 10. DRIVE SHAFT CONSTANT MESH GEAR    |
| 4. REAR AXLE (REAR UNIT) DRIVE GEAR          | 11. FRONT AXLE DRIVE SHAFT            |
| 5. REAR AXLE (REAR UNIT) DRIVE GEAR ASSEMBLY | 12. DRIVE SHAFT SLIDING GEAR          |
| 6. IDLER SHAFT CONSTANT MESH GEAR            | 13. IDLER SHAFT LOW SPEED GEAR        |
| 7. IDLER SHAFT                               | 14. IDLER SHAFT CONSTANT MESH GEAR    |

Figure 5-28.—Cross-section of a typical conventional transfer case.

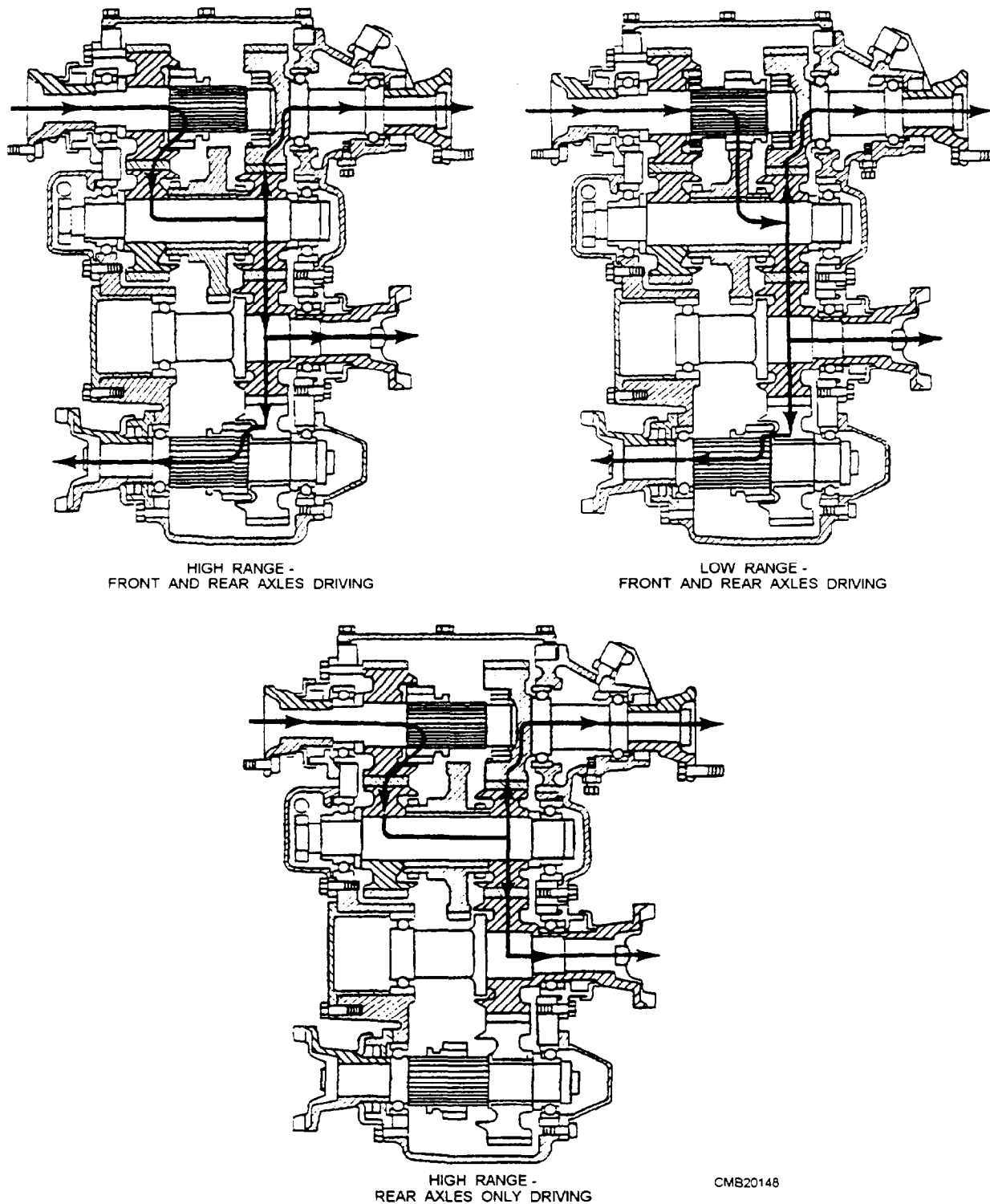

Figure 5-30.—Transfer case power flow.

(splined to the transmission main shaft) are in mesh with the internal teeth on the constant mesh gear, mounted on the transmission main shaft. Likewise, the external teeth of the front axle sliding gear are in mesh with the internal teeth of the constant mesh gear or the sliding clutches are

engaged. Disengagement of the drive to the front axle is accomplished by shifting the sliding gear on the front axle main shaft out of mesh with the constant mesh gear, permitting the latter to roll free on the shaft or sliding the clutches out of mesh.

- **Low Range** (fig. 5-29)—When using the low range in the transfer case, the sliding gear on the transmission main shaft is disengaged from the constant mesh gear and engaged with the idler gear on the idler shaft. This design reduces the speed by having the sliding gear mesh with the larger idler gear. The shifting linkage on some vehicles is arranged so shifting into low range is possible only when the drive to the front axle is engaged. This design prevents the operator from applying maximum torque to the rear drive only, which can cause damage.

### POSITIVE TRACTION TRANSFER CASE

The positive traction transfer case is very similar to the conventional transfer case—the basic difference being that a sprag unit has been substituted for the hand-operated sliding clutch on the front output shaft.

A sprag unit is a steel block shaped to act as a wedge in the complete assembly. In the sprag unit there are 42 sprags assembled into an outer race and held into place by two energizing springs (fig. 5-31). The springs fit into notches in the ends of the sprags and hold them in position. The outer race is the driven gear on the front output shaft. The inner race is on the front output shaft itself.

On these units, the transfer case is designed to drive the front axle slightly slower than the rear axle. During normal operation, when both front and rear wheels of the vehicle are turning at the same speed, the outer race of the sprag unit (in the driven gear) turns slower than the inner race (on the output shaft). This design prevents the sprags from wedging between the races. No lockup occurs and the front wheels turn freely; they are not driven (fig. 5-32). However, if the rear wheels should lose traction and begin to slip, they tend to turn faster than the front wheels; the outer race tends to turn faster than the inner race. When this happens, the sprags wedge or jam between the two races and the races turn as a unit to provide power to the front wheels (fig. 5-32).

### TRANSFER CASE MAINTENANCE AND SERVICE

The fluid level in a transfer case should be checked at recommended intervals. To check the lubricant level, remove the transfer case fill plug, which is normally located on the side or rear of the case. The

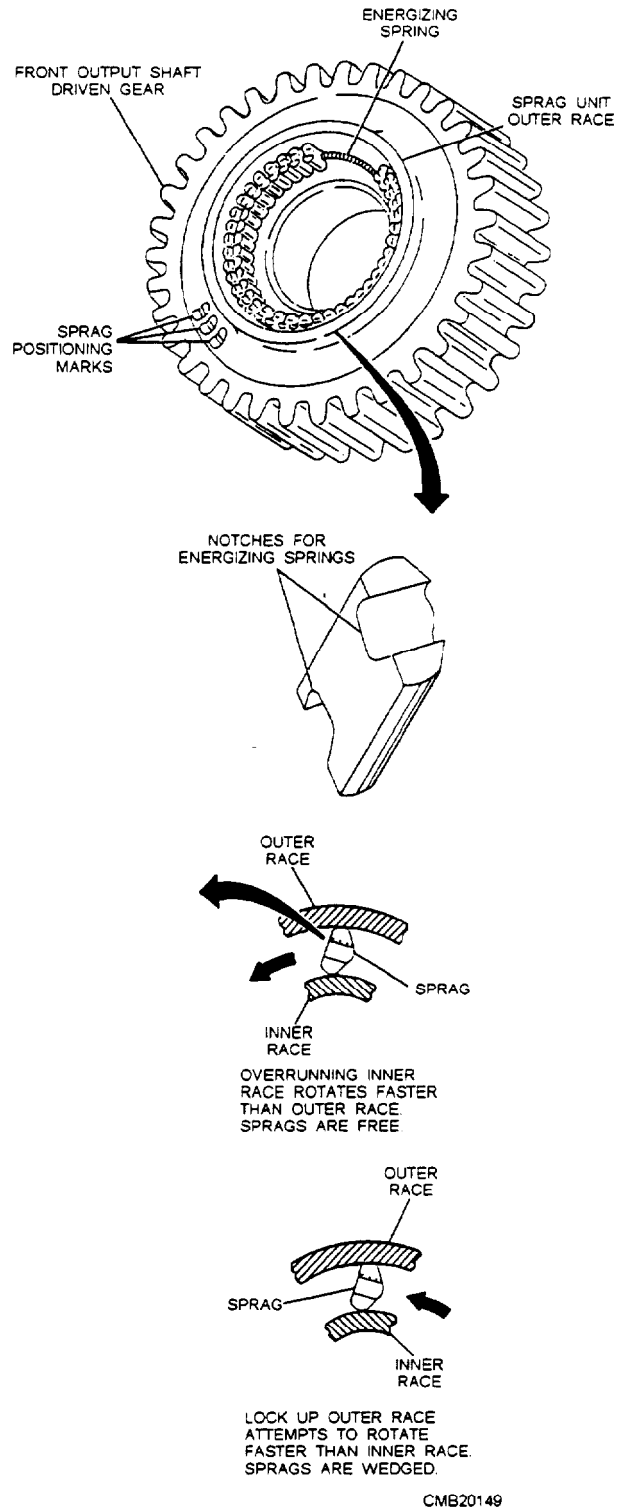

Figure 5-31.—Transfer case sprag unit.

lubricant should be almost even with the fill hole. If required, add the recommended type and amount.

The first indication of trouble within a transfer case, as with other components of the power train, is usually noisy operation. If an operator reports trouble, make a visual inspection before removing the unit

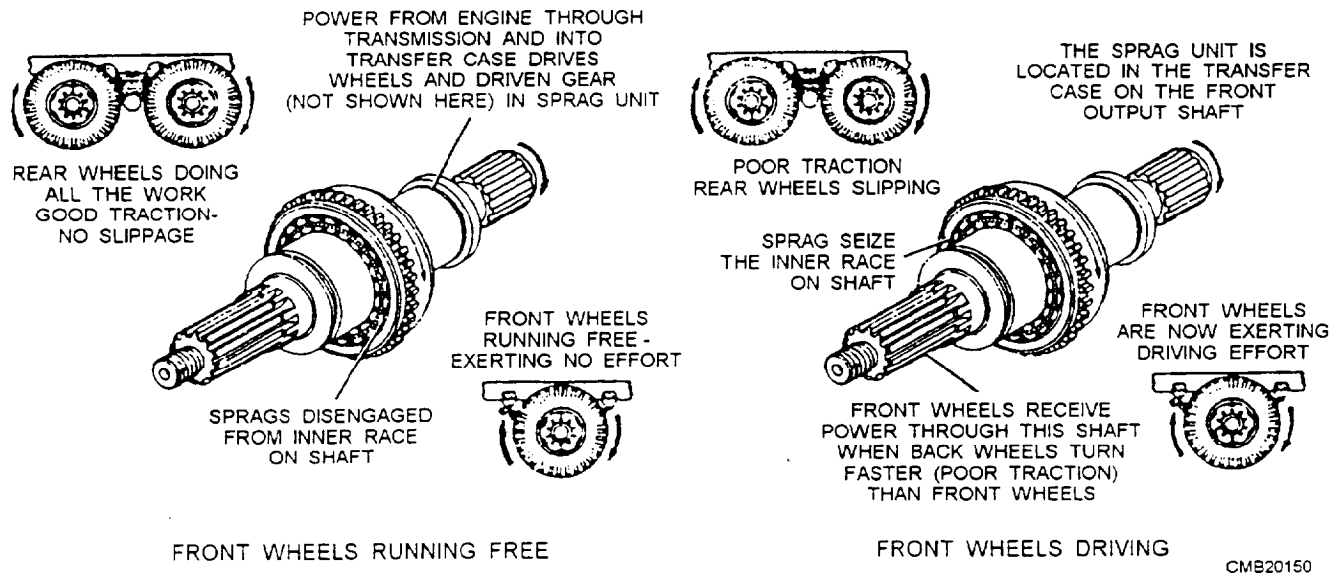

Figure 5-32.—Positive traction transfer case operation.

from the vehicle. Check for such things as oil level, oil leakage, and water in the oil.

Make sure the shift lever linkages are not bent or improperly lubricated. This will make it hard to shift or, in some cases, impossible to shift. Make sure other possible troubles, such as clutch slippage, damaged drive shaft, and damaged axles, have been eliminated.

Worn or broken gears, worn bearings, and excessive end play in the shafts can cause noisy operation. When transfer case service is required, follow the procedures outlined in the service manual. It will give directions for repairing the particular make and model.

#### REVIEW 4 QUESTION

- Q1. What is the gear ratio when a conventional transfer case is in high range?
- Q2. What component in a positive traction transfer case provides power to the front wheels when the rear wheel begins to slip?

#### POWER TAKEOFFS

**Learning Objective:** Explain the operation of a power takeoff unit.

A power takeoff (PTO) is an attachment for connecting the engine to power-driven auxiliary equipment. It is attached to the transmission, auxiliary transmission, or transfer case. A power takeoff

installed at the left side of a transmission is shown in figure 5-33. It is used to drive a winch at the front of a truck through a universal joint and drive shaft.

The simplest type of power takeoff is the single-speed, single-gear shown in figure 5-34. This unit may be bolted to an opening provided in the side of a transmission, as shown in figure 5-35.

Shims or spacers are often used to ensure proper contact is maintained between the teeth of the two meshing units. The sliding gear of the PTO can then mesh with, and be driven by, the countershaft gear of the transmission or the auxiliary transmission when engaged by the operator. The operator, by the use of a control lever, can move the gear in and out of mesh with the transmission gear. A spring-loaded ball (poppet) holds the shifter shaft in position.

On some vehicles you will find PTOs with gear arrangements that give you two speeds forward and one in reverse. Several forward speeds and a reverse gear are usually provided in a PTO unit used to operate a winch or hoist. Operation of this type of PTO is similar to that of the single-speed unit.

Faulty operation of a PTO is caused by damaged or broken linkage. To prevent this, exercise care when shifting. Trying to engage the unit with the transmission gears turning can damage the teeth, and rapid clutch engagement can break the housing. Rapid shifting may bend or damage the linkage. Forcing the control lever can bend or break the linkage.



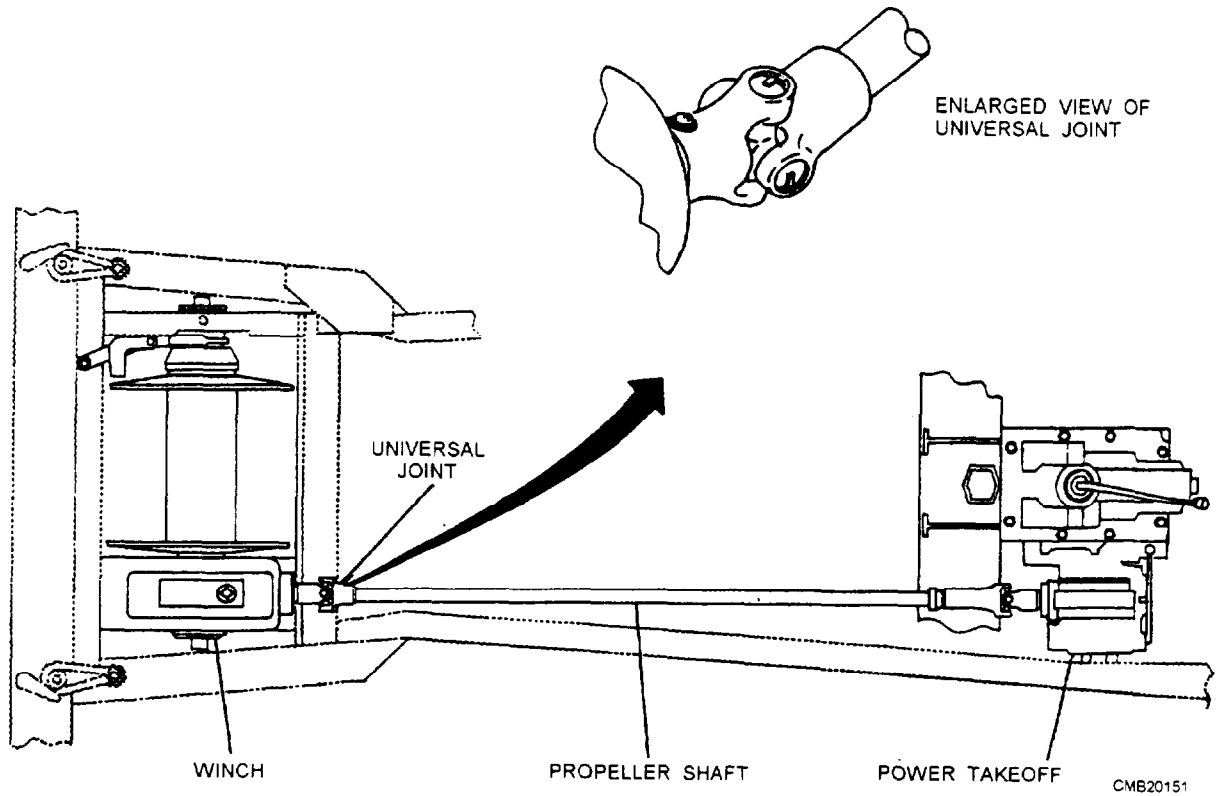

Figure 5-33.—Power takeoff and winch installation.

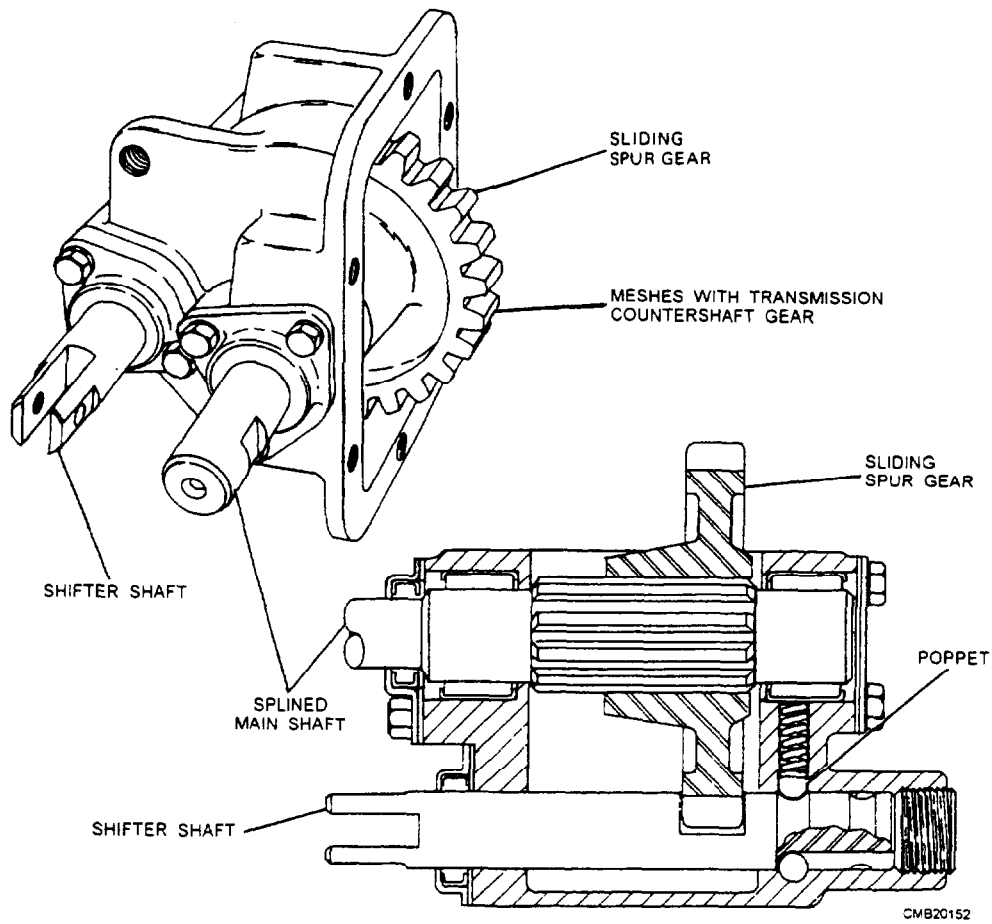
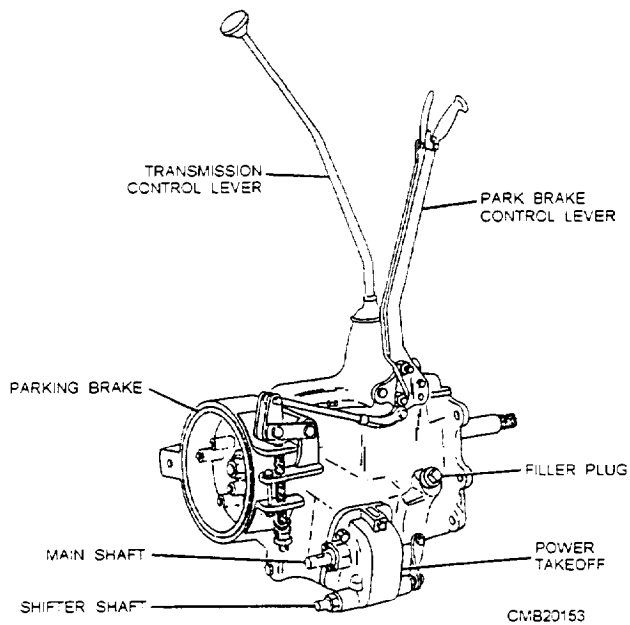

Figure 5-34.—Single-speed, single-gear power takeoff.



**Figure 5-35.—Single-speed, single-gear power takeoff installation.**

Adjustment of the linkage to compensate for wear and lubrication is normally all the maintenance required for the PTO unit. The gears and bearings are lubricated from the transmission sump.

If the PTO is to be removed for repairs, disconnect the drive shaft and shift linkage and drain the transmission. Once the transmission is completely drained, remove the bolts that secure the unit to the transmission. **DO NOT** misplace or lose any shims or spacers that are between the two housings. Once the unit is removed from the vehicle, the inspection and repair procedures are the same as for a transmission. When reinstalling or replacing the PTO, carefully follow the manufacturer's procedures on the installation shims or spacers to prevent damage or unit failure.

### REVIEW 5 QUESTIONS

*Q1. What is the simplest type of power takeoff (PTO)?*

### **REVIEW 1 ANSWERS**

- Q1. To send turning power from the transmission to the rear axle assembly, flex and allow up and down movement of the rear axle assembly, provide a sliding action to adjust for changes in drive line length, and provide smooth power transfer*
- Q2. True*
- Q3. To maintain alignment of two or more drive shafts when connected in tandem*
- Q4. Worn universal joint*
- Q5. Wiggle and rotate the universal joint back and forth*
- Q6. True*

### **REVIEW 2 ANSWERS**

- Q1. Differential*
- Q2. True*
- Q3. Pinion gear, ring gear*
- Q4. True*
- Q5. Limited slip differential*
- Q6. True*

### **REVIEW 3 ANSWERS**

- Q1. Breather vent*
- Q2. Full-floating axle*
- Q3. Rzeppa and Bendix- Weiss*
- Q4. Constant whirring or humming sound*
- Q5. Slide-hammer puller*

### **REVIEW 4 ANSWERS**

- Q1. 1:1*
- Q2. Sprag unit*

### **REVIEW 5 ANSWERS**

- Q1. Single-speed single-gear*



## CHAPTER 6

# CONSTRUCTION EQUIPMENT POWER TRAINS

### INTRODUCTION

**Learning Objective:** Identify the operational characteristics and components of drive trains, track assemblies, and track frames that are common to construction equipment power trains. Describe the operation of a winch. Identify the characteristics and maintenance of wire rope.

The construction equipment used by the Navy are equipped with power trains that are similar in many ways to the automotive vehicle power trains described in chapters 4 and 5. However, factors, such as size, weight, design, and use, of the construction equipment require power trains that vary greatly in configuration.

### DRIVE TRAINS

**Learning Objective:** Identify the operational characteristics and components of construction equipment drive trains.

There are numerous types of equipment used in construction, from crawler tractors to excavators. However, the way power is distributed varies from piece to piece. The most common drive trains used in

modern construction equipment are the mechanical and the hydrostatic drive trains.

### MECHANICAL DRIVE TRAIN

The mechanical drive train found in construction equipment is similar to that of the automatic transmission in that a transmission is used in conjunction with a torque converter and shifting is accomplished hydraulically when the operator moves the range selector lever.

### Power Shift Transmission

The power shift transmission (fig. 6-1) uses a torque converter and is designed to provide high-speed shifting through hydraulically actuated clutches. The transmission has two forward and two reverse speeds in both high and low ranges. The hi-lo shifting lever mounted on the transmission front cover controls shifting from one range to another.

### NOTE

The principles of a torque converter are presented in chapter 4 of this TRAMAN.

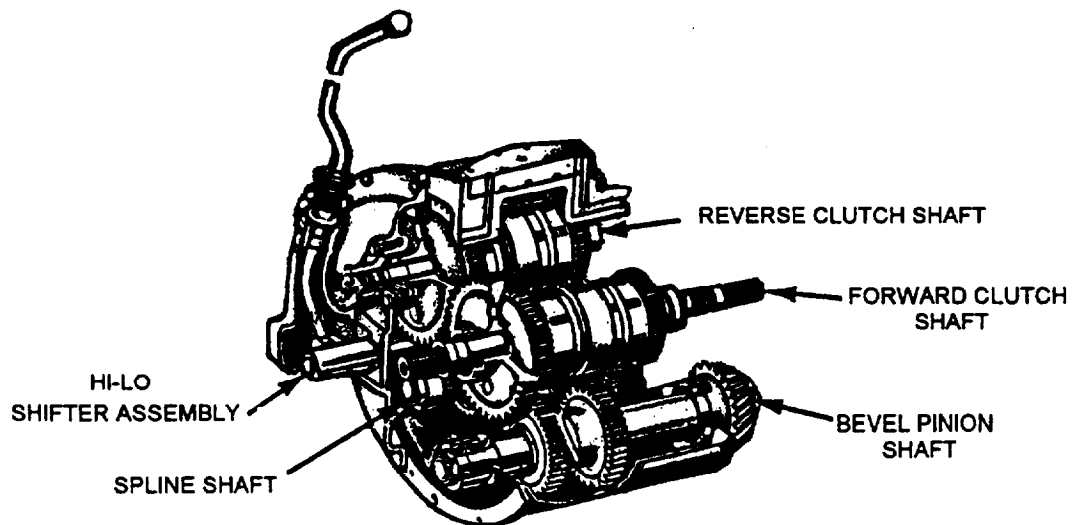

CMB2F242

Figure 6-1.—Power shift transmission.

The power shift transmission is coupled to the torque converter by a universal joint. Gears are mounted in the power shift transmission on four shafts, which are as follows:

- The REVERSE CLUTCH SHAFT (fig. 6-2) has a straight roller bearing at each end, with the reverse driven gear keyed to the front of the shaft. The shaft consists of first and second speed drive gears riding on bushings and is welded to the dual hydraulic clutch pack assemblies.
- The FORWARD CLUTCH SHAFT (fig. 6-3) rotates on straight roller bearings at the rear and ball bearings at the front, with the reverse drive gear keyed to the front of the shaft. As with the reverse clutch shaft, the forward clutch shaft consists of first and second speed drive gears riding on bushings and is welded to the dual hydraulic clutch pack assemblies.

- The SPLINE SHAFT (fig. 6-4) rotates on two straight roller bearings. The rear bearing is mounted in the transmission case; the front bearing is mounted in the transmission cover. The first and second driven gears are held in position on the spindle by snap rings and are constantly meshed with the first and second speed drive gears on the clutch shafts. The hi-lo driving gear slides freely on the shaft and drives the bevel pinion shaft when brought into mesh with either the high or low range driven gear by means of the hi-lo shifting lever.
- The BEVEL PINION SHAFT (fig. 6-5) consists of the high and low range gears, which are keyed to the shaft. The shaft is supported at the rear by a straight roller bearing, and, at the front, by a double-row taper roller bearing. The pinion gear is splined to the rear of the pinion shaft and is held in place by a nut. A shim pack is provided between the front bearing cage and the transmission case front cover for adjusting pinion depth.

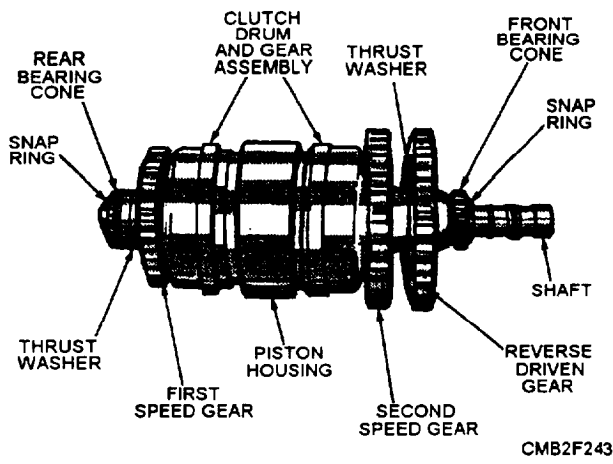

Figure 6-2.—Reverse clutch shaft.

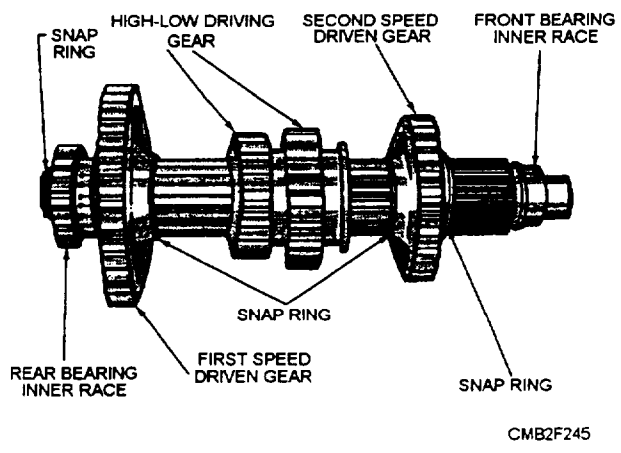

Figure 6-4.—Spline shaft.

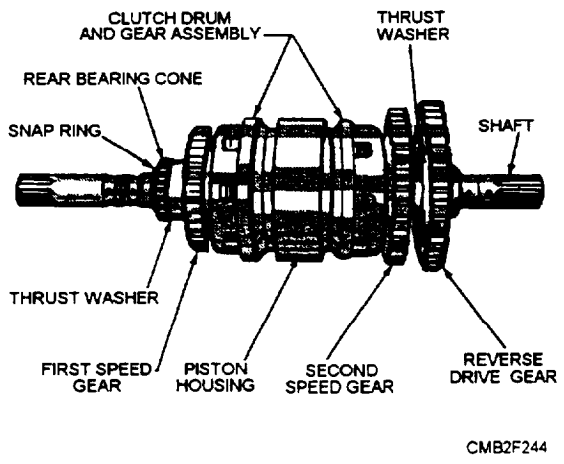

Figure 6-3.—Forward clutch shaft.

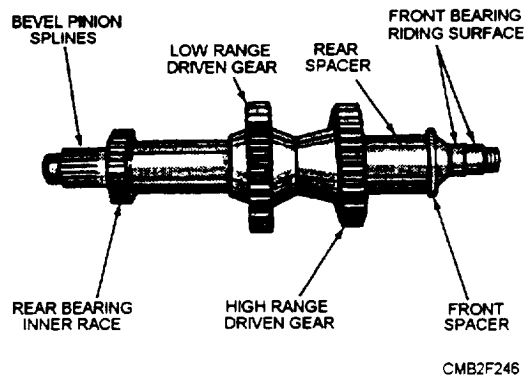

Figure 6-5.—Bevel pinion shaft.

**FORWARD AND REVERSE HYDRAULIC CLUTCH OPERATION.**—The forward and reverse hydraulic clutches actually have two clutches on a common shaft with a common apply force piston between them. The clutches allow the simple transfer of oil from the disengaging clutch into a cavity created by the engaging clutch. This allows a low volume of main pressure to actuate the clutch for high-speed shifting.

The heart of the clutch is contained in two pistons—the accelerator piston and the force piston. Pump oil volume is not needed to fill the applying clutch cavity, and only relatively low volume is needed to pressurize the clutch. In neutral, all accelerator and force piston cavities are filled with oil at lube pressure (10 to 25 psi). A selector valve, located on the top of the transmission case, directs the oil to the accelerator piston cavity and, in turn, to the force piston cavity. Once the pistons are filled with oil, they remain full under lube pressure. Other small cross-drilled passages furnish a constant supply of lube oil to the

drive gear bushing, the drum assemblies, and the clutch hubs for distribution through the clutch plates. In neutral, neither clutch is engaged, the drive gear and drum assemblies are free, and no torque is transmitted through the clutch, as shown in figure 6-6.

Upon application of the clutch, main oil pressure (approximately 200 to 300 psi) is directed through the clutch shaft for the specific side of the clutch desired. The oil enters the force piston cavity causing the clutch to engage (fig. 6-7). When engaged, the clutch holds the gear stationary in relation to the shaft. Power then flows from the shaft, via the clutch, to the gear.

When the transmission is returned to neutral, an immediate pressure drop occurs within the disengaging accelerator piston cavity and the compressed piston centering springs return the common apply force piston to its centered position or neutral.

**GEAR SHIFTER MECHANISM.**—On many older models, the gearshift lever is connected through

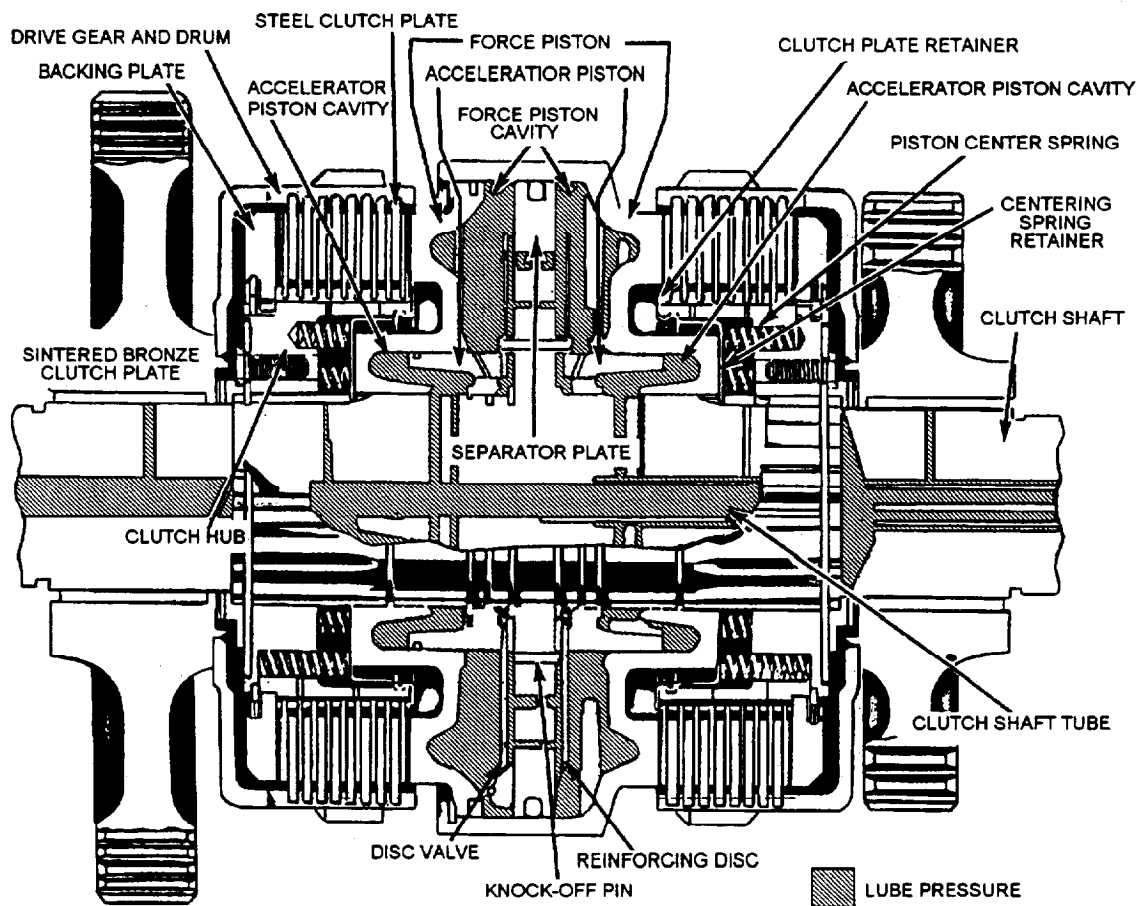

CMB2F247

Figure 6-6.—Flow of oil through the clutch in NEUTRAL position.

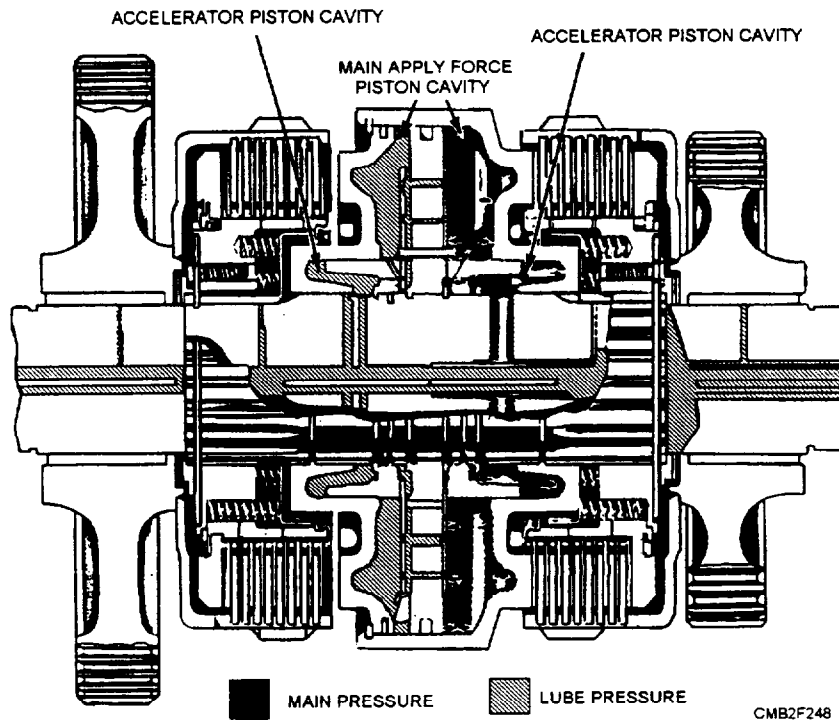

Figure 6-7.—Flow of oil through the clutch in ENGAGED position.

linkage to the range selector valve assembly on top of the transmission case. Movement of the gearshift lever positions the selector valve to allow main oil pressure to engage the desired clutch assembly.

In modern power shift transmissions, the gearshift lever is connected to a range selector valve by hydraulic means. A spool valve (pilot control valve), actuated by the gearshift lever, directs main oil pressure to the range selector valve and causes it to direct main oil pressure to the desired clutch assembly.

The hi-lo-shifting lever (on the transmission front cover) is held in position by a poppet lock in the hi-lo shifting housing. To shift from one range to another, the engine must be running and the gearshift lever must be in NEUTRAL position. This allows main oil pressure from the pump to pass through a drilled hole in the pilot valve and through an oil line to the shifter housing. Here it releases the poppet lock to enable shifting.

### Planetary Gearsets

Some power shift transmissions use planetary gearsets to perform the same functions as the transmission just described. A planetary gearset (fig. 6-8) consist of three members—sun gear, ring gear, and a planetary carrier that holds the planetary gears in

proper relation with the sun and ring gear. The planetary gears are free to "walk" around the sun gear or inside the ring gear.

To cause a reduction or increase in torque, six different methods of connecting this gearset to the power train are possible (fig. 6-9). Direct drive is achieved by locking any two members together, and neutral is obtained by allowing all the gears to turn freely.

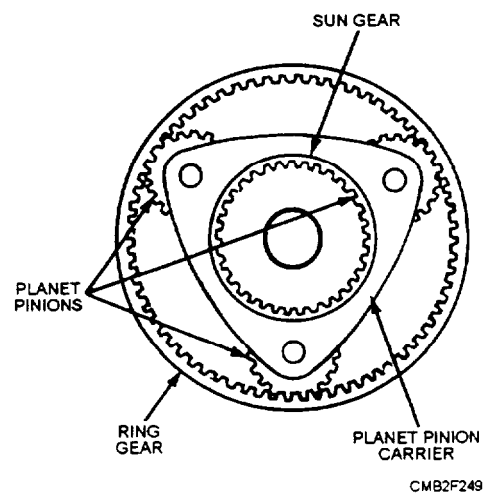
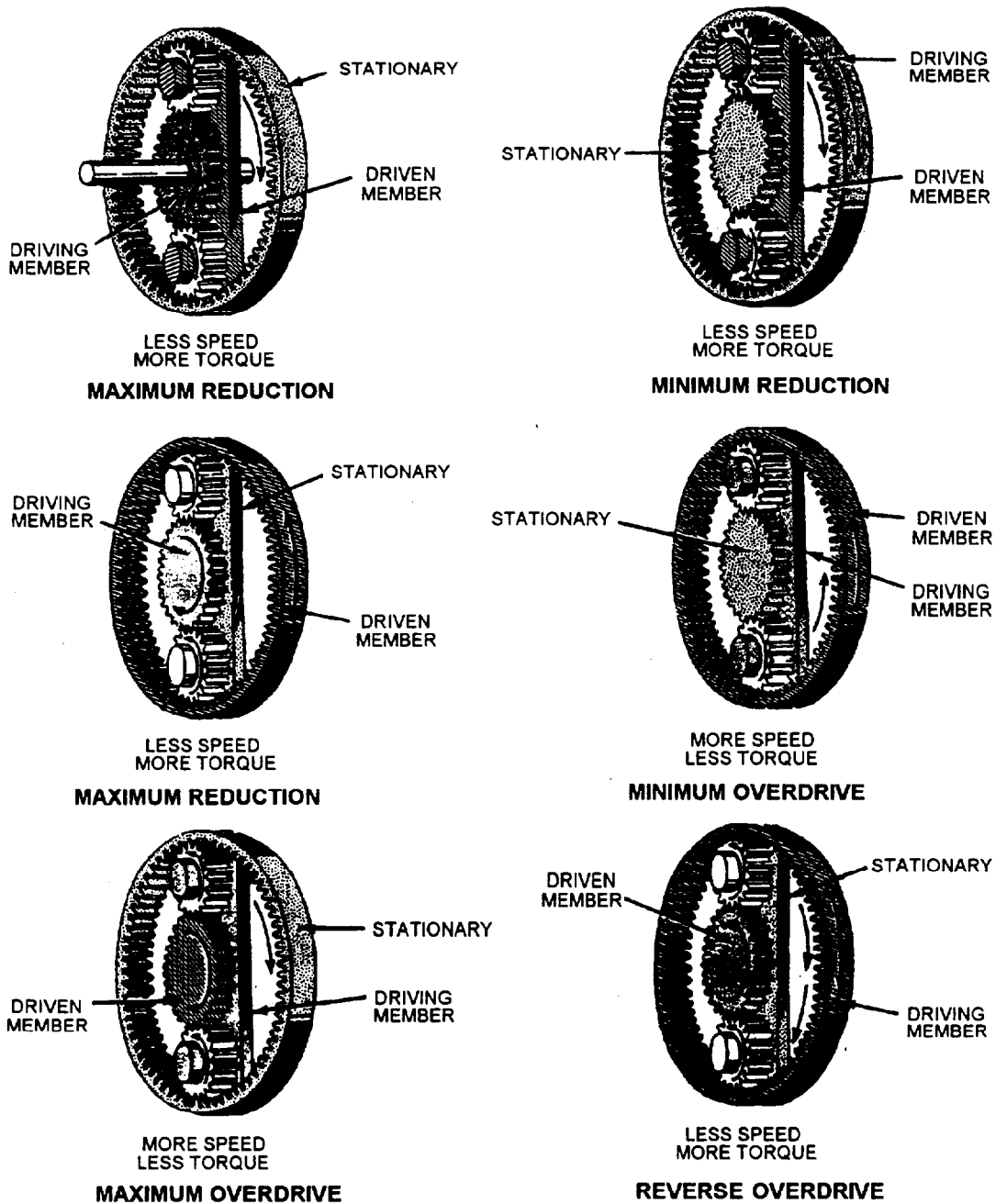

Figure 6-8.—Planetary gearset.





CMB2F250

Figure 6-9.—Planetary gear arrangements that will provide an increase or decrease in speed.

In figure 6-9 notice the direction of rotation as power is applied to the various members and others are stationary. In actual application, planetary gearsets are used as single or multiple units, depending on the number of speed (gear) ranges desired.

On tracked equipment, power for turning the drive sprockets may flow through a planetary gear arrangement that provides maximum reduction (fig. 6-9). The sun gear forces the planetary gears to revolve

in the stationary ring gear and move the carrier in the same direction of rotation as the sun gear. The carrier is connected to the hub on which the sprocket is mounted, causing it to rotate with the carrier. This arrangement produces the maximum torque and speed reduction obtainable from a planetary gearset.

### Planetary Steering

Some tracked equipment may be steered by a system that combines planetary steering and pivot



the steering brake hub. This hub then rotates with the planetary carrier, and no power is transmitted to the sprocket drive shaft.

Occasionally, an adjustment of the steering brake is required to prevent slippage when it is engaged. Consult the manufacturer's service manual for adjustment procedures.

### Pivot Brakes

The pivot brakes on tracked equipment are of the multiple disc type. Pulling the steering brake levers fully to the rear operates them. The middle discs (splined to the sprocket drive shaft) have laminated linings. The intermediate discs (held in position by studs) are smooth steel discs. An actuating disc assembly is two steel plates with steel balls between them. The assembly is located in the center of the discs and is connected to the operating linkage.

Ramps are machined on the steel plate of the actuating disc assembly, so when the brakes are applied, the steel balls move up the ramps and force the plates apart. Movement of the plates causes the discs to be squeezed together and to stop rotation of the sprocket drive shaft. When these brakes are fully applied, the tracks will stop. The steering levers are linked to the brakes independently to actuate them for sharp turns.

Adjustment of the pivot brakes is required to provide adequate braking with the steering levers. An adjustment is required when the steering levers can be pulled against the seat with the engine running. Consult the manufacturer's service manual for proper adjustment procedures.

### HYDROSTATIC DRIVE TRAIN

The hydrostatic drive is an automatic fluid drive that uses fluid under pressure to transmit engine power to the drive wheels or tracks.

Mechanical power from the engine is converted to hydraulic power by a pump-motor team. This power is then converted back to mechanical power for the drive wheels or tracks.

The pump-motor team is the heart of the hydrostatic drive system. Basically, the pump and motor are joined in a closed hydraulic loop; the return line from the motor is joined directly to the intake of the pump, rather than to the reservoir (fig. 6-11). A charge pump maintains system pressure, using supply oil from the reservoir.

The hydrostatic drive functions as both a clutch and transmission. The final gear train then can be simplified with the hydrostatic unit supplying infinite speed and torque ranges as well as reverses speeds.

To understand hydrostatic drive, you must understand two principles of hydraulics:

- Liquids have no shape of their own.
- Liquids are not compressible.

The basic hydrostatic principle is as follows (fig. 6-12):

- Two cylinders connected by a line both filled with oil. Each cylinder contains a piston.
- When a force is applied to one of the pistons, the piston moves against the oil. Since the oil will not compress, it acts as a solid connection and moves the other piston.

In a hydrostatic drive, several pistons are used to transmit power—one group in the PUMP sending power to another group, in the MOTOR. The pistons are in a cylinder block and revolve around a shaft. The pistons also move in and out of the block parallel to the shaft.

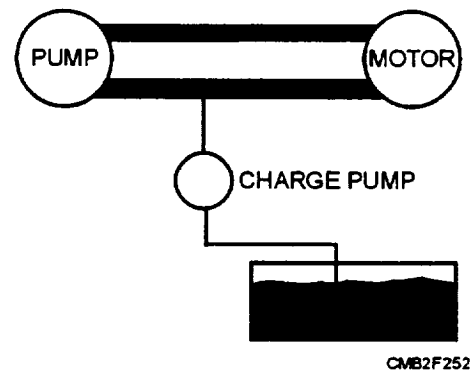

Figure 6-11.—Pump and motor form a closed hydraulic loop.

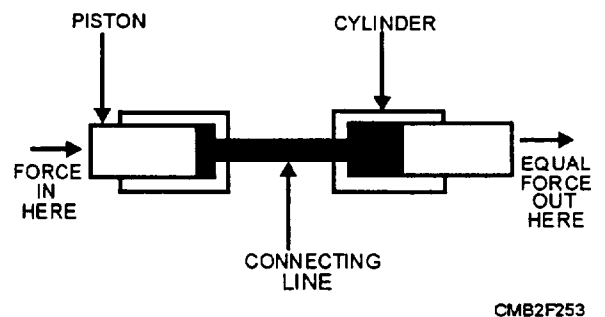

Figure 6-12.—Basic hydrostatic principle.

To provide a pumping action for the pistons, a plate, called a SWASH PLATE, is located in both the pump and motor (fig. 6-13). The pistons ride against the swash plates. The angle of the swash plates can be varied, so the volume and pressure of oil pumped by the pistons can be changed or direction of the oil reversed. A pump or motor with a movable swash plate is called a variable-displacement unit. A pump or motor with a fixed swash plate is called a fixed displacement unit. There are four pump-motor combinations, which are as follows (fig. 6-14):

Fixed displacement pump driving a fixed displacement motor (fig. 6-14, view A). This setup will give you constant horsepower and

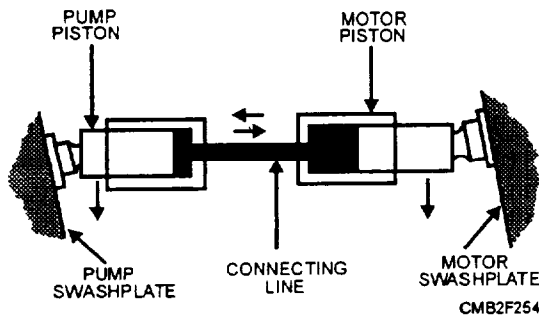

Figure 6-13.—Connected cylinders with swash plates.

torque at the output with a steady input speed. If input speed varied, horsepower and speed will vary but torque will remain constant. Because both the pump and motor are fixed displacement, this system is like a gear drive; it transmits power without altering the speed or horsepower between the engine and the load.

- Variable displacement pump driving a fixed displacement motor (fig. 6-14, view B). Since the pump is variable, output speed is variable and torque output is constant for any given pressure. This setup provides variable speed and constant torque.
- Fixed displacement pump driving a variable displacement motor (fig. 6-14, view C). In this setup changing the motor displacement varies output speed. When motor displacement decreases, output speed increases, but output torque drops. When the setup is balanced, it gives a constant horsepower output.
- Variable displacement pump driving a variable displacement motor (fig. 6-14, view D). This setup gives an output of both constant torque and constant horsepower. It is the most flexible of all the setups, but it is also the most difficult to control.

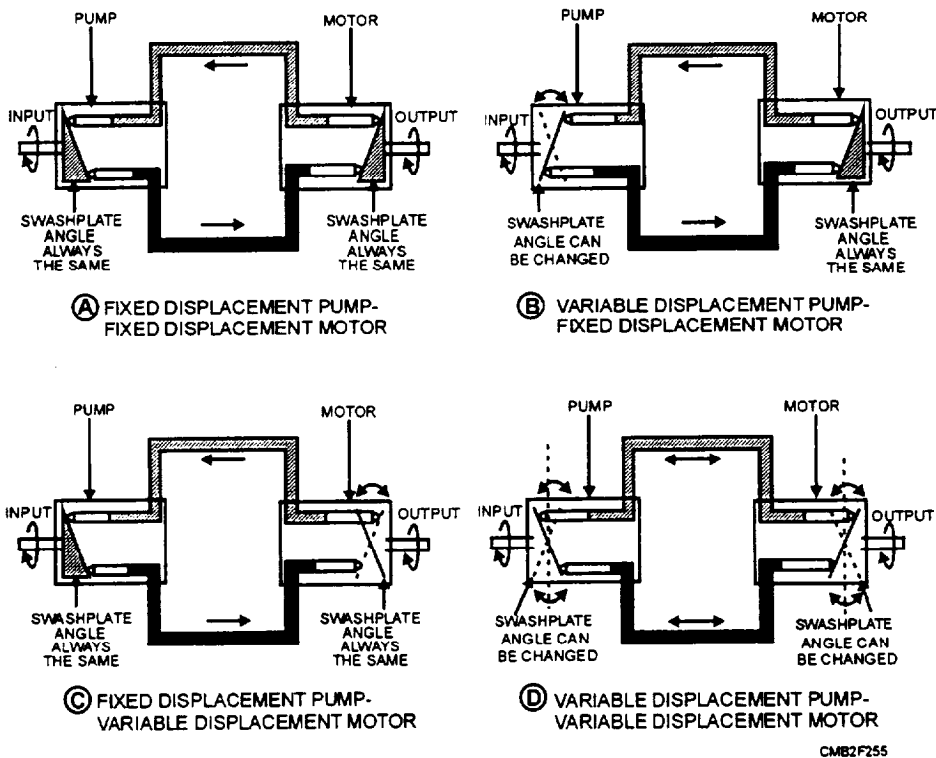

Figure 6-14.—Pump and motor combinations for hydrostatic drives.

The direction of output shaft rotation can be reversed in variable setups by shifting either the pump or the swash plate of the motor over center.

Remember three factors control the operation of a hydrostatic drive. These factors are as follows:

- RATE of oil flow—gives the speed
- DIRECTION of oil flow—gives the direction
- PRESSURE of the oil—gives the power

The pump is driven by the engine of the machine and is linked to the speed set by the operator. It pumps a constant stream of high-pressure oil to the motor. Since the motor is linked to the drive wheels or tracks of the machine, it gives the machine its travel speed.

The advantages of hydrostatic drive are as follows:

- Infinite speeds and torque
- Easy one-lever control
- Smooth shifting
- Shifts "on the go"
- High torque available for starting up

- Flexible location—no drive lines
- Low maintenance and service
- Reduces shock loads
- Compact size
- Eliminates clutches and large gear trains

### Hydrostatic Drive Operation

For you to understand how a hydrostatic drive operates, we will explain the operation of a typical system. The system we will use has an axial piston pump and motor which is the 'most common hydrostatic drive system. The pump has a variable displacement, while the motor has a fixed displacement. Now look at the complete system in operation—forward, neutral, and reverse.

**FORWARD** (fig. 6-15).—When the operator moves the speed control lever forward, the spool in the displacement control valve, also known as the FNR valve (Forward, Neutral, and Reverse), moves from its NEUTRAL position. This action allows pressure oil to flow into the upper servo cylinder forcing the swash

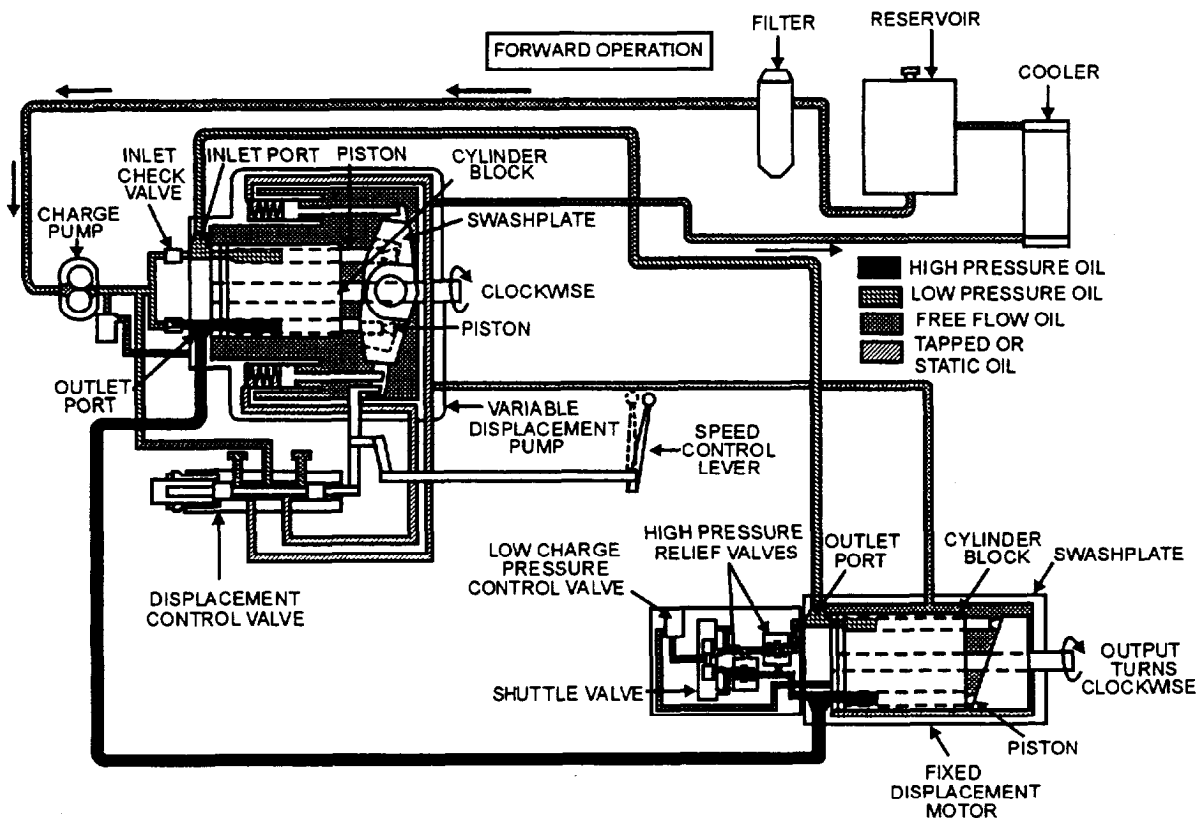

CMB2F256

Figure 6-15.—Forward operation.

plate to tilt. Oil, expelled by the opposing servo cylinder, returns through the displacement control valve (FNR valve) to the pump case.

As the swash plate reaches the tilt set by the speed control lever, the displacement control valve (FNR valve) spool returns to a NEUTRAL position, trapping the oil to both servo cylinders and holds the swash plate in its titled position. The swash plate will remain titled until the operator moves the speed control lever.

With the pump drive shaft and cylinder block rotating clockwise and the swash plate is titled to the rear, it is now time to start pumping. As the cylinder rotates past the pump inlet port, the inlet check valve opens: oil is then forced by the charge pump into the piston bores that align with the inlet port under low charge pressure. As rotation continues, oil is forced out of the outlet port at high pressure by the pump pistons when they align with the outlet port. This flow of oil drives the motor.

The distance the pistons reciprocate in and out of the cylinder block depends on the angle of the swash plate of the pump. This determines the volume of oil displaced per revolution of the pump. The greater the angle, the greater the volume and the more oil flows from the pump. As the angle of the swash plate is varied so will the volume of oil displaced from the pump.

As pressure oil enters the inlet port of the motor, the pistons that align with the inlet port pushes against the swash plate. Since the fixed swash plate is always tilted, the pistons slide down the inclined surface and the resulting forces rotate the cylinder block. This, in turn, rotates the output shaft driving the machine forward.

As the cylinder block continues to rotate clockwise, oil is forced out the outlet port at low pressure and returns to the pump where it is recirculated through the pump and back to the motor.

This is called a “closed system” because the oil keeps circulating between the pump and the motor. The only extra oil comes from the charge pump that maintains a given flow of oil through the system whenever the machine is running.

A shuttle valve, located in the motor manifold and controlled by high oil pressure, prevents high oil pressure from entering the low-pressure side of the system. This action keeps the charge circuit open to the low-pressure valve while the system is running.

The high-pressure relief valve, located in the motor manifold, monitors the pressure of the forward flow of oil and protects the system from too high pressures. If pressure exceeds the rated psi, a relief valve opens and oil bypasses the cylinder block in the motor. This will either slow or stop the machine. The bypassed oil returns to the pump. This action continues until the load is reduced below the rated psi. Then the relief valve closes and oil again flows to the cylinder block, moving the machine forward.

**NEUTRAL** (fig. 6-16).—With the speed control lever in neutral, free oil flows from the reservoir through the oil filter to the charge pump. The charge pump pumps the oil past the high charge pressure control valve and into the main pump housing. The oil circulates through the housing and returns through the oil cooler and back to the reservoir.

Trapped oil is held in the cylinder block of the pump, in the motor, and in the connecting lines between the pump and motor by two check valves in the pump end cap.

When the control lever is in neutral, the swash plate in the pump is also in neutral and the pistons within the pump are not pumping. Therefore no oil is being moved to provide either forward or reverse motion.

The cylinder block in the pump rotates in a clockwise direction and is driven by the engine of the equipment. Rotation is viewed from the drive shaft end of the pump. Because the oil is not being pumped to the motor, the cylinder block in the motor is stationary and the output shaft does not move.

## NOTE

With the drive system in neutral, the high charge pressure control valve, (located at the charge pump) controls pump pressure. When the system is activated for reverse or forward, the low charge pressure control valve located in the motor manifold controls the charge pressure at a lower psi.

**REVERSE** (fig. 6-17).—As the speed control valve is moved to reverse, the spool in the displacement control valve (FNR valve) moves out of neutral allowing pressure oil to flow into the lower servo cylinder, tilting the swash plate forward.

When the swash plate reaches its desired tilt, which is set by the control lever, the displacement control spool returns to neutral. This action traps the

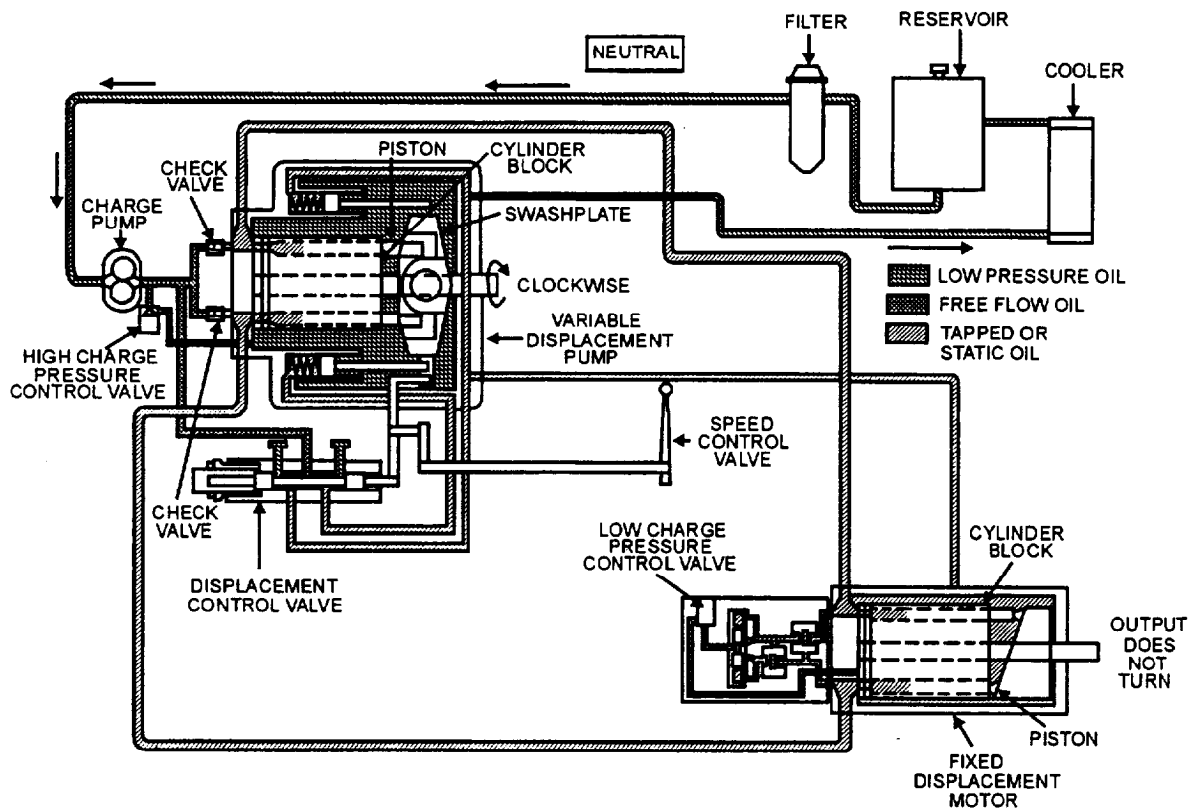

CMB2F257

Figure 6-16.—Neutral operation.

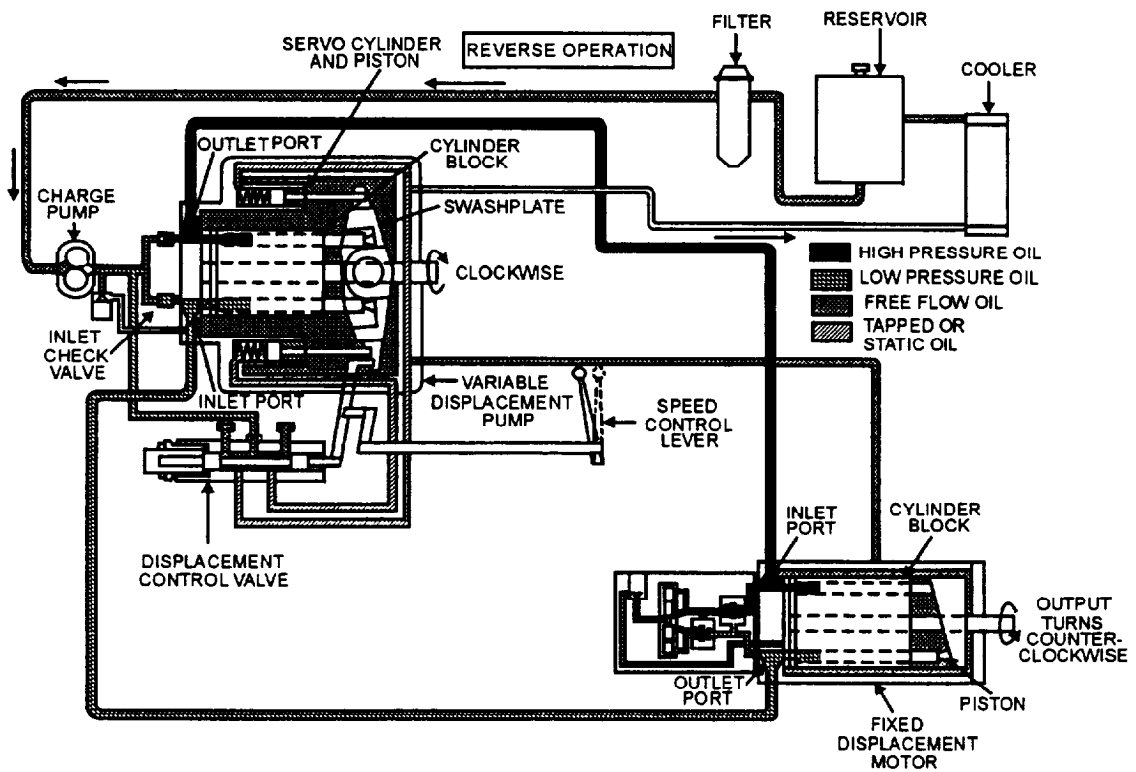

CMB2F258

Figure 6-17.—Reverse operation.

oil to both servo cylinders and keeps the swash plate tilted. The swash plate will remain in position until the speed control lever is moved again by the operator.

With the swash plate tilted forward and the pump drive shaft and cylinder block rotating clockwise, the ports reverse and the inlet port becomes the outlet and the outlet port becomes the inlet. As the pump cylinder block rotates past the pump inlet port, a check valve opens and oil is forced by the charge pump into the piston bores that align with the inlet port of the pump. As rotation continues, the oil is pressurized and forced out of the outlet port of the pump by each of the pistons, as they align with the outlet port. This action forces oil to flow to the motor, and as high-pressure oil from the pump enters the inlet port of the motor, the pistons are pushed against the swash plate. The pistons slide down the inclined surface of the swash plate, rotating the cylinder block. This action rotates the drive shaft counterclockwise, driving the piece of equipment in reverse. As the motor cylinder block continues to rotate, oil is forced out the outlet port at low pressure and returns to the pump.

#### **NOTE**

The PUMP DRIVE SHAFT and cylinder block always rotate clockwise, but the MOTOR DRIVE SHAFT and cylinder block rotate in clockwise and counterclockwise directions, depending on the direction of the oil entering the pump.

### **Maintenance of Hydrostatic Drives**

As with any hydraulic system, the hydrostatic drive system is fairly easy to maintain. The fluid provides a lubricant and protects against overload. Like any other mechanism, it must be operated properly; too much speed, too much heat, too much pressure, or too much contamination will cause damage.

Before removing any part of the system, ensure that the area is clean. Use steam-cleaning equipment if available; however, do NOT let any water into the system. Ensure that all hose and line connections are tight. If steam cleaning is not possible, diesel fuel or a suitable solvent may be used. Be certain to remove all loose dirt and foreign matter that may contaminate the system. Impurities, such as dirt, lint, and chaff, cause more damage than any one thing. Always seal openings when doing work to prevent foreign matter from entering the system.

Clean the workbench or table before disassembling any hydrostatic system component for servicing. Be sure that all tools are clean and free of dirt and grease.

#### **NOTE**

NEVER perform internal service work on the shop floor or ground or where there is a danger of dust or dirt being blown into the parts.

Before disassemble of any system component for internal service, certain items must be available. These items include the following:

- Clean plastic plugs of various sizes to seal the openings when removing hydraulic hoses and lines.
- Clean plastic bags to place over the ends of the lines and hoses. Secure the bags to the line and hoses with rubber bands.
- A container of solvent to clean internal parts. Ensure that all parts are clean before replacing them. Compressed air may be used to dry the parts after cleaning.
- A container of hydraulic fluid to lubricate the internal parts as they are reassembled.
- A container of petroleum jelly to lubricate surfaces where noted by the manufacturer during reassembly.

Anytime the components are serviced and reassembled, always install new O rings, seals, and gaskets. This provides tight seals for mating parts and eliminates leakage.

#### **NOTE**

For instructions on the disassembly and reassembly of hydrostatic components, refer to the manufacturer's service manual.

Never operate the hydraulic system empty. Always check the fluid supply after servicing the system. If fluid is to be added to the system, use ONLY the fluid recommended in the service manual.

### **REVIEW 1 QUESTIONS**

*Q1. A power shift transmission has what total number offorward and reverse speeds?*



- Q2. What shaft in a power shift transmission has the reverse drive gear keyed to the front of the shaft?
- Q3. What components are the heart of a hydrostatic drive system?
- Q4. What component in a hydrostatic drive system maintains system pressure by using oil from the reservoir?
- Q5. A hydrostatic drive pump with a movable swash plate is known as what type of pump?

## TRACK AND TRACK FRAMES

**Learning Objective:** Identify the operational components of the track and track frame. Describe the maintenance procedures used on tracks and track frame assemblies.

The undercarriage of crawler-mounted equipment contains two major components—TRACK ASSEMBLY and TRACK FRAME. This undercarriage (fig. 6-18) is provided on equipment that must have positive traction to operate efficiently.

### TRACK ASSEMBLY

The track assembly consists of a continuous chain surrounding the track frame and drive sprocket. The links of the chain provide a flat surface for the track rollers to pass over, as they support the equipment. Track shoes are bolted to the outside links of the chain and distribute the weight of the equipment over a large surface area.

### Track Chain

Figure 6-19 shows a cutaway view of a section of track chain, showing the internal arrangement of the pins and bushings. As the tractor operates, the drive

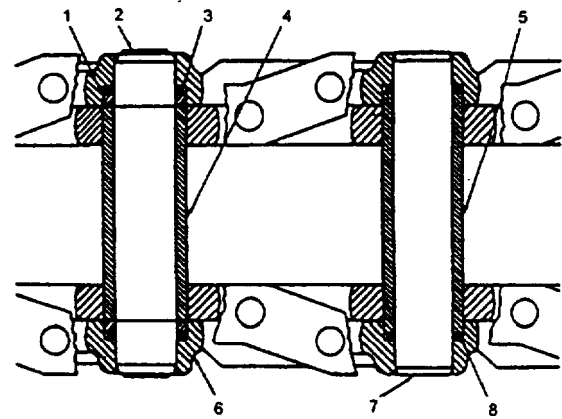

- |                               |                               |
|-------------------------------|-------------------------------|
| 1. SPACER                     | 5. TRACK BUSHING              |
| 2. MASTER PIN                 | 6. LINK                       |
| 3. CONED-DISK<br>SEAL WASHERS | 7. TRACK PIN                  |
| 4. MASTER BUSHING             | 8. CONED-DISK<br>SEAL WASHERS |

CMB2F260

Figure 6-19.—Track chain cutaway.

sprocket teeth contact the track pin bushings and propel the tractor along the track assembly.

The pins and bushings wear much faster than other parts of the track because of their constant pivoting, as the track rotates around the track frame. This pivoting results in internal wear of both the pin and the bushing. As the pins and bushings wear, the track lengthens. When it does, the track is adjusted to remove excessive slack.

Bushings that show lots of wear on the outside are good indicators of inner wear that is also nearing the maximum allowed by the manufacturer, if the track is to be rebuilt. To determine whether the track should be removed for rebuilding or replacement, measure the outside of the bushings and track "pitch" (length of the

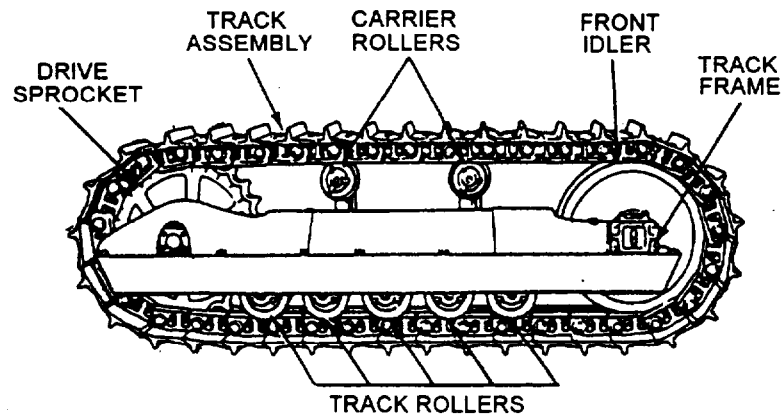

CMB2F259

Figure 6-18.—Side view of crawler tractor chassis.

track). Use an outside caliper and ruler, as shown in figure 6-20. Measure the outside of the bushing where it shows the most wear and compare it to the manufacturer's specifications.

Measure track pitch with a ruler or tape measure after tightening the track to remove any slack, as shown in figure 6-21.

Should the bushing wear or track length be excessive, remove the track for rebuilding unless facilities and time do not permit. Rebuilding a track will nearly double the useful life of the pin and bushings.

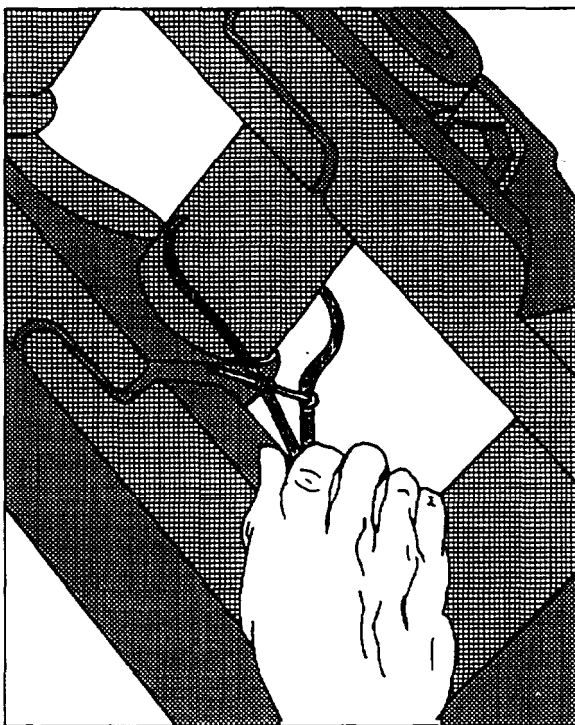

CMB2F261

Figure 6-20.—Bushing wear measurement.

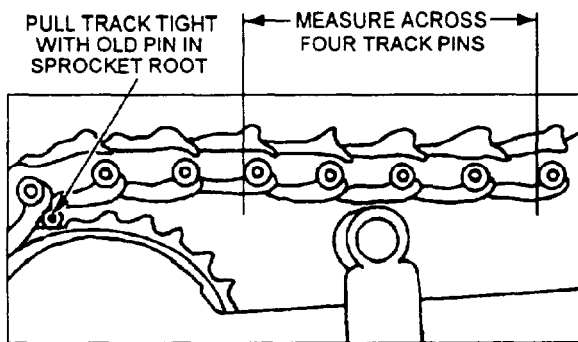

CMB2F262

Figure 6-21.—Track pitch measurement.

### Track Shoes

The most common track shoe is the grouser shoe shown in figure 6-22. This shoe is standard on all crawler-mounted dozers. The extreme service track shoe (fig. 6-23) is equipped on crawler-mounted dozers that operate primarily in rocky locations, such as rock quarries and coral beaches. Notice the grouser, or raised portion of the shoe, is heavier than the standard grouser shoe.

Another shoe common to track-mounted front-end loaders is the multipurpose shoe. This shoe has three grousers that extend a short distance above the shoe and are equally spaced across its face. The multipurpose shoe allows more maneuverability with less wear on the track and track frame components.

#### NOTE

The grouser absorbs most of the wear and its condition indicates when the track needs replacement or overhaul.

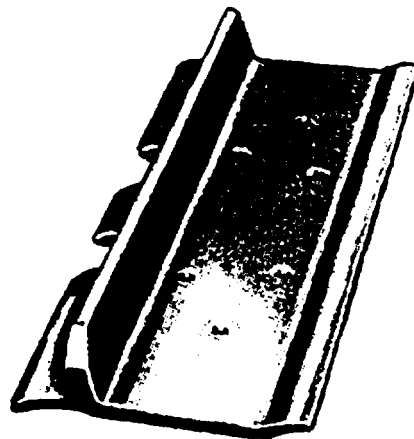

CMB2F263

Figure 6-22.—Standard grouser shoe.

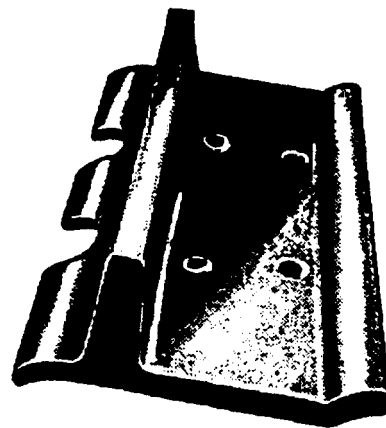

CMB2F264

Figure 6-23.—Extreme service track shoe.

## TRACK FRAME

The track frame, as the name implies, serves as a framework and support for the track assembly, rollers, front idler, recoil spring, and adjusting mechanism.

Track frame alignment may be fixed or shim adjusted depending on the manufacturer. When shims are used, there are a couple of ways alignment may be maintained. One way is using shims where the frame attaches to the rear pivot and also near the center of the track frame where it is mounted against the main frame guide brackets. Another way is to use a diagonal brace and shims at the rear pivot to align the track frame.

### Track Frame Rollers

Two types of track frame rollers are used on tracked equipment—those located on the lower portion of the track frame which supports the weight of the tractor, and those above the track frame which supports the track assembly, as it passes over the track frame.

- Carrier rollers (fig. 6-24) are single-flanged rollers mounted on brackets, which extend above the track frame and supports the track assembly. Two of these rollers are on each side of the tractor. The flange extends upward between the links of the track chain, keeping the chain in alignment between the drive sprocket and the front idler.

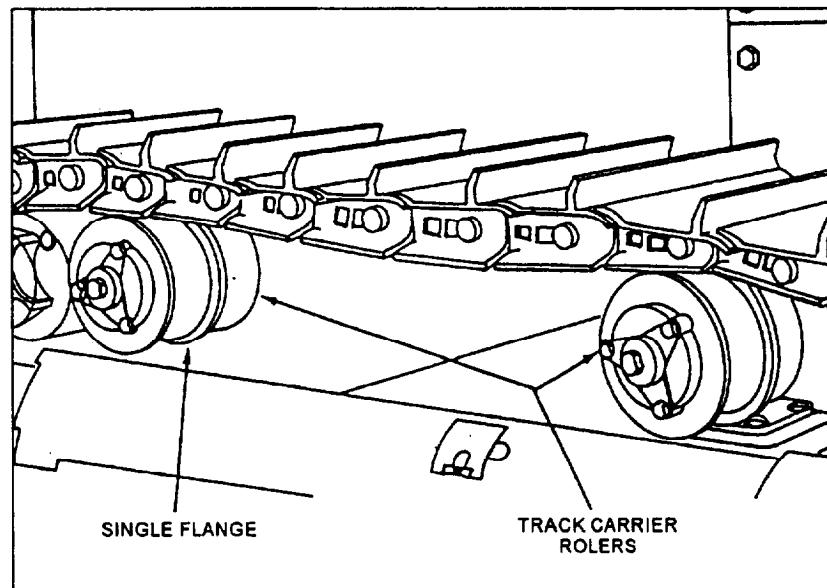
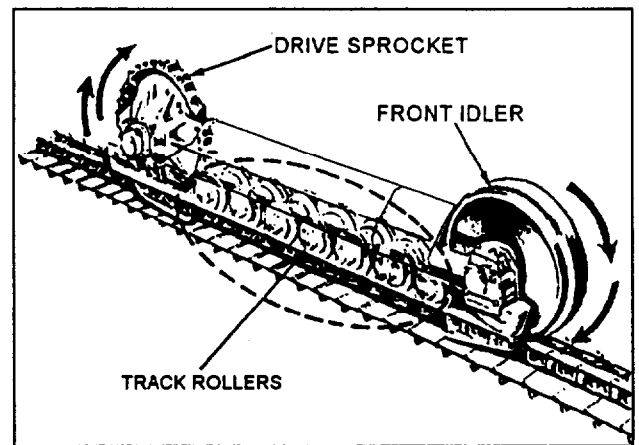

Figure 6-24.—Track carrier rollers.

- Track rollers (fig. 6-25) are double- and single-flanged rollers that supports the weight of the tractor, ensures that the track chain is aligned with the track frame at it passes under the rollers, and prevents side to side track movement and derailment. In a normal arrangement, a double-flanged roller is directly in front of the drive sprocket, followed by a single-flanged roller. The rollers alternate forward to the front idler.

The front idler, as shown in figure 6-25, serves as a guiding support for the track chain. The idler is spring-loaded and mounted on slides or guides that allow it to move back and forth inside the track frame, as the tractor passes over uneven terrain. The spring loading



CMB2F266

Figure 6-25.—Track rollers in position in the track frame..

effect causes the idler to maintain the desired tension regardless of operating conditions.

### Recoil Spring

The recoil spring is a large coil spring placed in the track frame in a way that enables the spring to absorb shock from the front idler. The spring is compressed before installation and held in place by stops or spacers. The track adjusting mechanism, by pressing against the spring stop, maintains the desired tension on the track assembly by holding the idler and yoke in a FORWARD position. The operation of the recoil springs depends on the amount of tension on the track.

### Adjusting Mechanism

The adjusting mechanism must be extended enough to remove slack between the front idler and spring. This adjustment may be made by either manual (fig. 6-26) or hydraulic (fig. 6-27) means. Many older

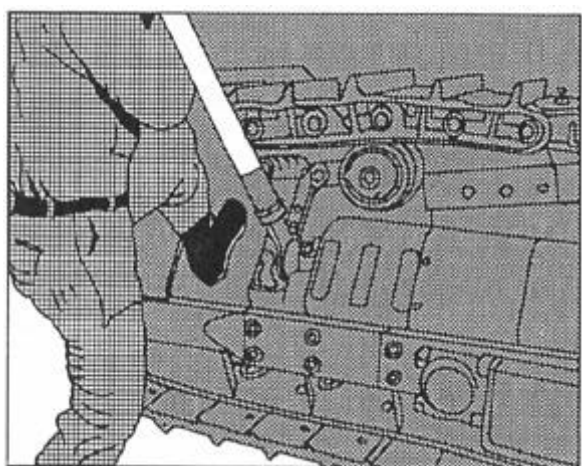

CMB2F267

Figure 6-26.—Manual track adjustment.

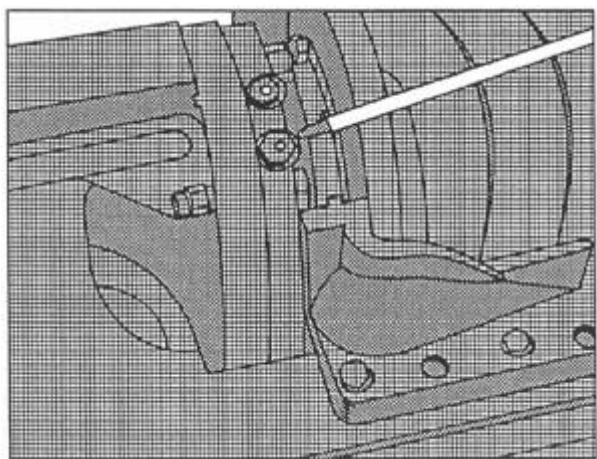

CMB2F268

Figure 6-27.—Hydraulic track adjuster.

tractors have manual adjustments, whereas newer tractors are adjusted hydraulically with a grease gun. Grease is pumped into the yoke cylinder and extends it until enough tension is placed on the recoil spring to remove the slack from the track. Tension is released by loosening the vent screw located next to the adjustment fitting.

### NOTE

DO NOT lubricate the adjustment fitting when performing maintenance on the tractor.

### Track Guiding Guards

Accumulation of rock and dirt packed in the track causes the tracks to tighten, resulting in additional wear and stress on track components. The use of track guiding guards minimizes these sources of possible depreciation. Another function of the track guiding guards is maintaining proper track alignment; this is considered secondary, but actually is the most important function.

Guiding guards should be repaired when damaged, since a damaged guard is worthless as far as protection for track components or assisting in maintaining track alignment. When installing new tracks on a piece of equipment, check the condition of the guards. These guards should be in a condition to guide the track squarely into alignment with the rollers properly. The three guards are as follows:

- The **FRONT GUIDING GUARDS** receive the track from the idler and hold it in line for the first roller. The front roller then can fully be utilized for its intended purpose—carrying its share of the load without having to climb the side of an improperly aligned track.
- The **REAR GUIDING GUARDS** hold the track in correct alignment with the driving sprocket, permitting a smooth even power flow from the sprocket to the track. With proper alignment, gouging of the track link and sprocket teeth is eliminated.
- The **CENTER GUIDING GUARDS** or track roller guards are available as attachments. These center guards keep the track in line between the rollers when operating in rocky, steep, or uneven terrain. The center guards reduce the wear on roller flanges and track links.

## MAINTENANCE OF TRACK AND TRACK FRAME ASSEMBLIES

Some maintenance of track and track frames are performed at the jobsite by the field maintenance crew. This maintenance consists of track adjustment, lubrication based on hours as required by the manufacturer, and inspection of the track and track frame components.

### Track Adjustment

If the tracks are adjusted too tightly, there will be too much friction between the pins and bushings when the track links swivel as they travel around the sprocket and front idler. This friction causes the pins, bushings, links, sprocket, and idler to wear rapidly. Friction in a tight track also robs the tractor of needed horsepower.

Tracks that are too loose fail to stay aligned and tend to come off when the tractor is turned. As a result, the idler flanges, roller flanges, and the sides of the sprocket teeth wear down. A loose track will whip at high tractor ground speed, damaging the carrier rollers and their supports. If loose enough, the drive sprockets will jump teeth (slide over track bushings) when the tractor moves in reverse. Should this happen, the sprocket and bushings will wear rapidly.

One method for determining proper track tension is placing a straightedge over the front carrier roller and idler with all the slack removed from the rest of the track. Using a ruler, measure from the top of the track shoe to the bottom edge of the straightedge (fig. 6-28). For the correct measurement, refer to the manufacturer's manual.

If it becomes necessary to adjust the track in the field, the following method can be used. Remove all

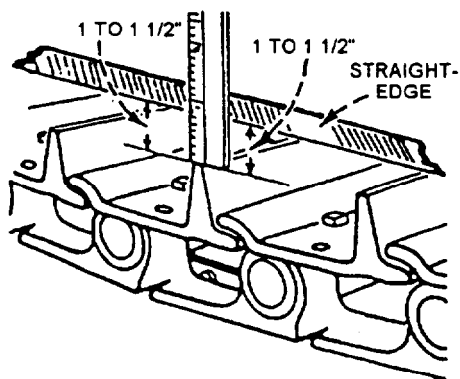

Figure 6-28.—Checking track adjustment.

slack from the track. With all slack removed, release the pressure until the front idler moves back 1/2 inch. This will provide the required slack in the track until the tractor can be readjusted to the manufacturer's specifications.

### NOTE

Always check the manufacturer's maintenance manual for the proper procedures when adjusting tracks.

### Lubrication

The track pins and bushing are hardened and require no lubrication. Many rollers and idlers are equipped with lifetime seals that are factory lubricated and sealed. However, track rollers, carrier rollers, and idlers equipped with grease fittings must be lubricated on a scheduled basis that is set by the manufacturer.

### NOTE

ONLY use a hand-operated grease gun on these fittings and pump only until resistance is felt. Further pumping will damage the seals.

### Inspection

When performing routine maintenance, inspect the complete track and undercarriage for signs of abnormal wear, leaking rollers or idlers, and misaligned, loose, or missing parts. Should you find any loose track shoes, you should check the torque on all the shoe bolts. Any bolts not meeting specifications should be retightened to the prescribed torque.

If the track appears to be out of alignment, report this to your supervisor who shall determine what action is required. Leaking roller and idler seals should be replaced as soon as possible to prevent any further damage to the equipment.

### Shop Repairs

Repairs made to tracks and track frames in the maintenance shop are usually limited to replacing roller or idler seals and bearings or repairing a hydraulic track adjuster. On occasion, you may find a roller or track that is badly worn and requires replacement.

## NOTE

NEVER replace components of the track or track frame without consulting the wear limitation charts in the manufacturer's service manual.

**TRACK REMOVAL** (fig. 6-29).—Steps for the removal of the track are as follows:

1. **RELEASE TRACK TENSION.** Either by manually backing off the track adjuster or loosening the vent screw on the hydraulic track adjuster.

2. **REMOVE THE MASTER PIN.** The master pin can be identified by a locking device or hole drilled in its end that distinguishes it from the other pins in the chain. Move the tractor backward slowly or, on some models, forward to bring the master pin just below the level of the drawbar. Place a block under the grouser on a shoe that allows the master pin to be centered on the front idler. With the master pin centered on the front idler, remove any locking device. If the master pin had a locking device, the pin can be removed by using a sledgehammer and a soft metal driftpin. Should the pin be drilled, a portable press must be used to remove the pin. Do not lose the bushings, which may drop out with the pin.

3. **REMOVE THE TRACK FROM THE CARRIER ROLLERS AND IDLER.** Slowly move the tractor forward or backward away from the loose ends of the track. Make sure no one is in the way of the tractor or the loose end of the track when it falls off the sprocket or front idler.

4. **MOVE THE TRACTOR OFF THE TRACK.** Place a plank at the rear of the track. The plank should be about the same thickness as the track, yet narrow enough to fit between the track frame and guards, and long enough so that the entire tractor can rest on the plank.

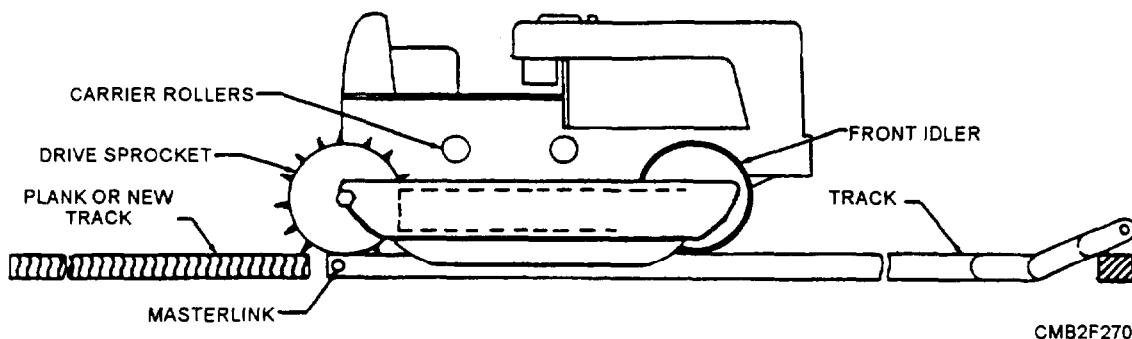

Figure 6-29.—Removing tracks.

## NOTE

After removing the tracks, always see that the tractor is securely blocked while repairs are being performed.

Anytime a track is removed, thoroughly inspect the track frame components for excessive wear and misalignment. Removal, disassembly, and replacement vary by model and manufacturer. Consult the manufacturer's service manual for exact procedures.

**REPLACING TRACKS.**—To replace the tracks, back the tractor off the plank and onto the new tracks so the drive sprocket properly meshes with the track rail. Continue backing until the tractor is just ahead of the rear end of the track. Then place a bar in the track (fig. 6-30), and help the track climb over the sprocket, carrier rollers, and idler as the tractor is driven forward. When the track comes together, install the master pin and any locking device. Once the track is together, adjust the track tension using the manufacturer's recommended procedures.

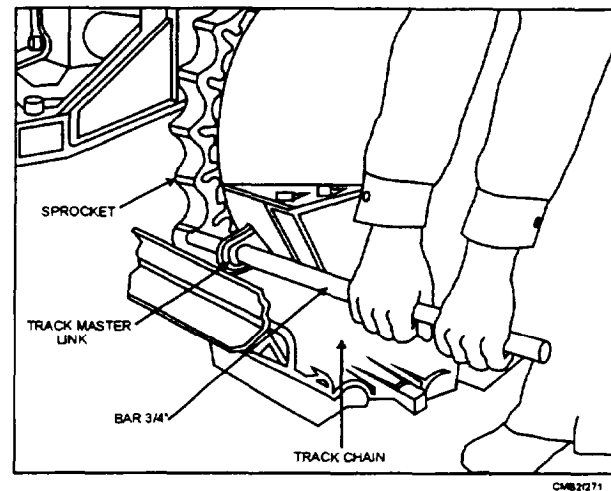

Figure 6-30.—Pulling track over sprocket.

## REVIEW 2 QUESTIONS

- Q1. What components of a track chain wear faster than the other components?
- Q2. What measuring device is used to measure track pitch?
- Q3. What is the most common type of track shoe?
- Q4. What component of the track frame serves as a guiding support for the track chain?
- Q5. What component of the track frame holds the track in correct alignment with the driving sprocket?

## WINCHES AND WIRE ROPE

**Learning Objective:** Describe the operation of a winch. Identify the characteristics and maintenance of wire rope.

Using a winch and some type of rigging, a vehicle can pull itself or another vehicle through such obstacles as muddy or rough terrain. This is the primary reason for providing winches on military vehicles.

In the Naval Construction Force (NCF), an in-depth management program for maintenance and use of all rigging gear is required to ensure all operations are performed safely and professionally. These guidelines are outlined in the COMSECONDCOMTHIRDNCBINST 11200.11, *Use of Wire Rope*

*Slings and Rigging Hardware in the Naval Construction Force and the NAVFAC P-307, Management of Weight Handling Equipment.*

## WINCHES

Most winches that you will encounter are used on tactical vehicles and construction equipment. On tactical equipment, the winch is mounted behind the front bumper and is secured to the front cross member of the frame or between the two side frame rails. In some cases, it may be mounted behind the cab of the vehicle. The typical front-mounted winch is a jaw-clutch worm-gear type (fig. 6-31).

The jaw-clutch winch consists of a worm gear that is keyed to a shaft. A bushed drum is mounted on the worm-gear shaft, which is controlled by a hand-operated sliding clutch. The worm shaft is driven by power from the power takeoff through a solid drive shaft and universal joints. The universal joint yoke, connected to the worm shaft of the winch, has a provision for a shear pin that is made of mild steel. This pin has a predetermined breaking strength that allows it to shear when the winch is overloaded.

A hand-operated sliding clutch is keyed to the worm-gear shaft outside of the winch drum and must be engaged with the jaws on the side of the winch drum when the winch is to be operated. Disengagement of the sliding clutch permits the drum to turn on the worm-gear shaft.

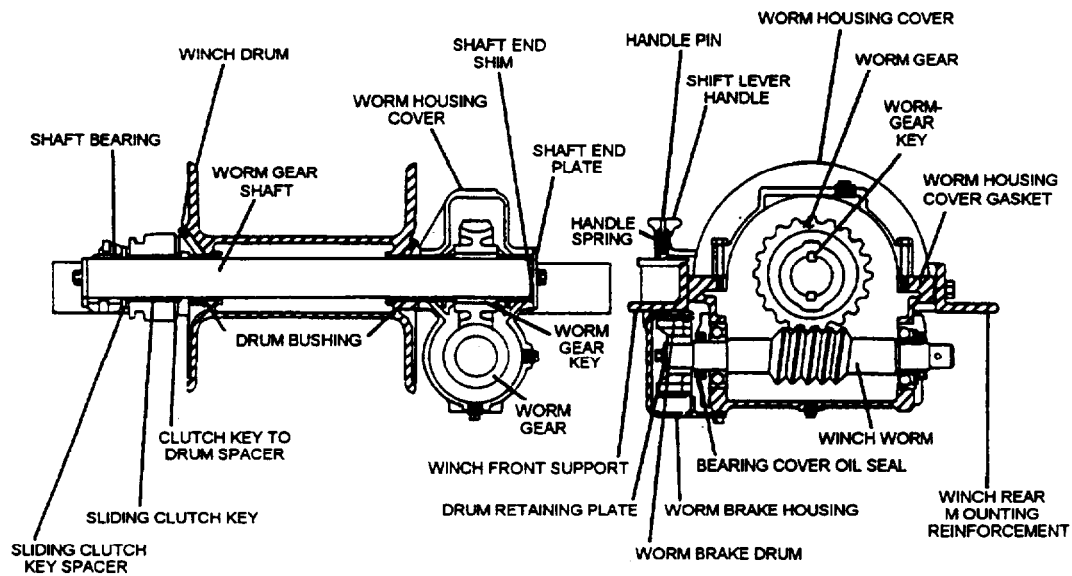

CMB2F272

Figure 6-31.—Jaw-clutch worm-gear winch.

The two brakes that provide control of the winch drum are as follows:

- The WORM BRAKE SHAFT prevents the winch drum from rotating under load when the power takeoff is disengaged.
- The SHIFTER BRACKET BRAKE prevents the drum from overrunning the cable when the cable is being unreeled.

Some winches may be equipped with an automatic level-winding device to spool the cable on the drum in tight, even coils, and layers. This prevents crushing of the cable due to loose, crossed coils and layers, and it allows off leads of the cable while maintaining level winding.

A broken shear pin usually causes faulty operation of winches. Internal damage of the winch can be caused by the use of a shear pin that has too high a breaking strength. Internal winch failure, resulting from overload, is commonly found to be sheared keys or a broken worm shaft. Often, when the cable is wound unevenly under tension, the winch housing will be cracked or broken. This will require replacement of the assembly.

## NOTE

NEVER install a shear pin that is not of the proper shearing strength. Damage to the winch will occur when overloaded.

The winch that you will most likely encounter on construction equipment is the one attached to the rear of a crawler tractor, also known as a dozer. It is mounted on the rear of the dozer (fig. 6-32) and is directly geared to the rear power takeoff. This arrangement permits development of a line of pull that is 50 to 100 percent greater than straight dozer pull. The winch is used for uprooting trees and stumps, hoisting and skidding stress, freeing mired equipment, and support amphibious construction operations.

When performing maintenance on a winch, ensure that the gear case has the recommended amount and type of lubricant. Should disassembly of the winch be required for repairs, follow the procedures given in the manufacturer's manual.

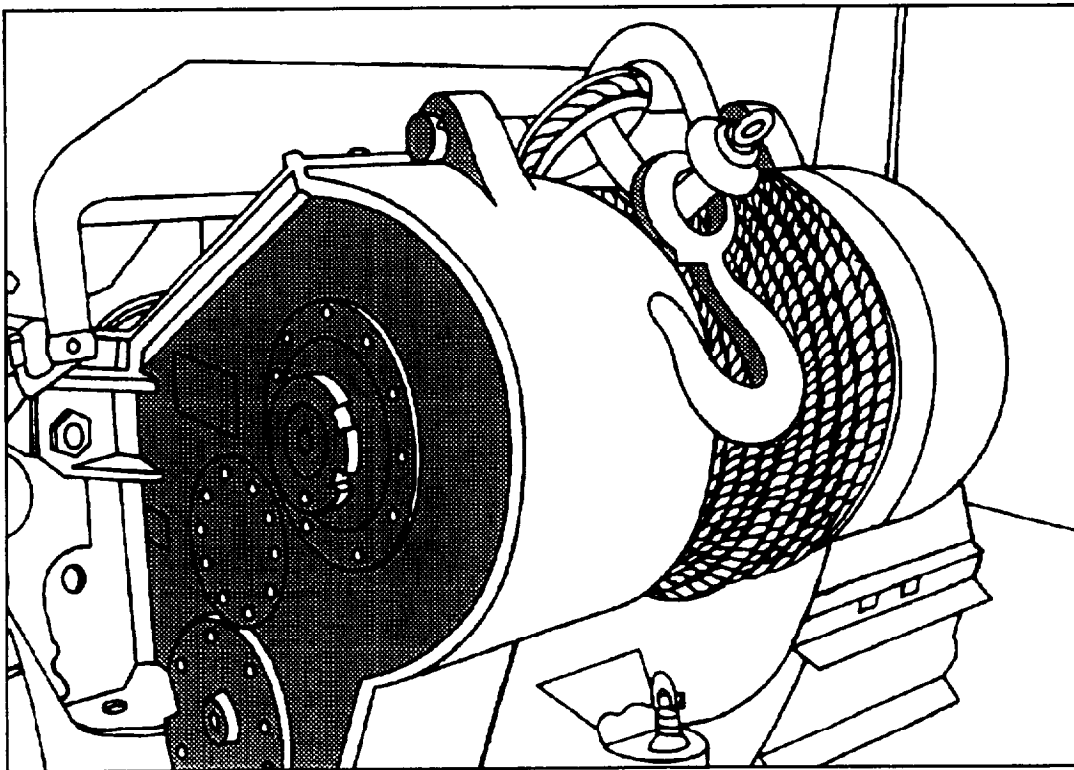

CMB2F273

Figure 6-32.—Winch attachment on a dozer.



## WIRE ROPE

Many of the movable components on cranes and attachments are moved by wire rope. Wire rope is a complex machine, composed of a number of precise moving parts. The moving parts of wire rope are designed and manufactured to bear a definite relationship to one another to have the necessary flexibility during operation.

Wire rope may be manufactured by either of two methods. If the strands, or wires, are shaped to conform to the curvature of the finished rope before laying up, the rope is termed *PREFORMED WIRE ROPE*. If they are not shaped before fabrication, the wire rope is termed *NON-PREFORMED WIRE ROPE*. The most common type of manufactured wire rope is preformed. When cut, the wire rope tends not to unlay and is more flexible than non-preformed wire rope. With non-preformed wire rope, twisting produces a stress in the wires; therefore, when it is cut or broken, the stress causes the strands to unlay.

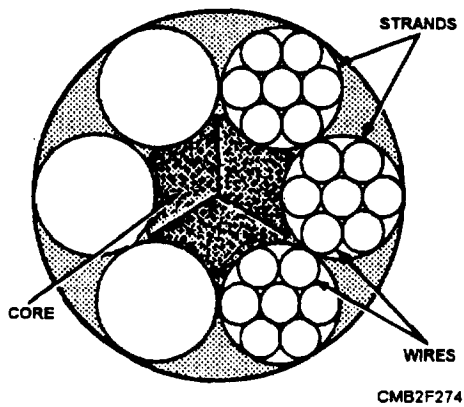

Figure 6-33.—Composition of wire rope.

## CAUTION

When the wire is cut or broken, the almost instantaneous unlaying of the wire or strands of the non-preformed wire rope can cause serious injury. This situation is apt to occur especially to someone who is careless or not familiar with this characteristic of the rope.

### Composition of Wire Rope

Wire rope is composed of three parts—wires, strands, and core (fig. 6-33). A predetermined number of wires of the same or different size are fabricated in a uniform arrangement of definite lay to form a strand. The required number of strands are then laid together symmetrically around the core to form the wire rope.

**WIRE.**—The basic component of the wire rope is the wire. The wire may be made of steel, iron, or other metal in various sizes. The number of wires to a strand varies, depending on the purpose for which the wire rope is intended. The number of strands per rope and the number of wire per strand designate wire rope. Thus a 1/2-inch 6 x 19 rope has six strands with nineteen wires per strand. It has the same outside diameter as a 1/2-inch 6 x 37 rope that has six strands with thirty-seven wires (of a smaller size) per strand.

**STRAND.**—The design arrangement of a strand is called the construction. The wires in the strand may be all the same size or a mixture of sizes. The most common strand constructions are Ordinary, Seale, Warrington, and Filler (fig. 6-34) as follows:

- ORDINARY construction wires are all the same size.

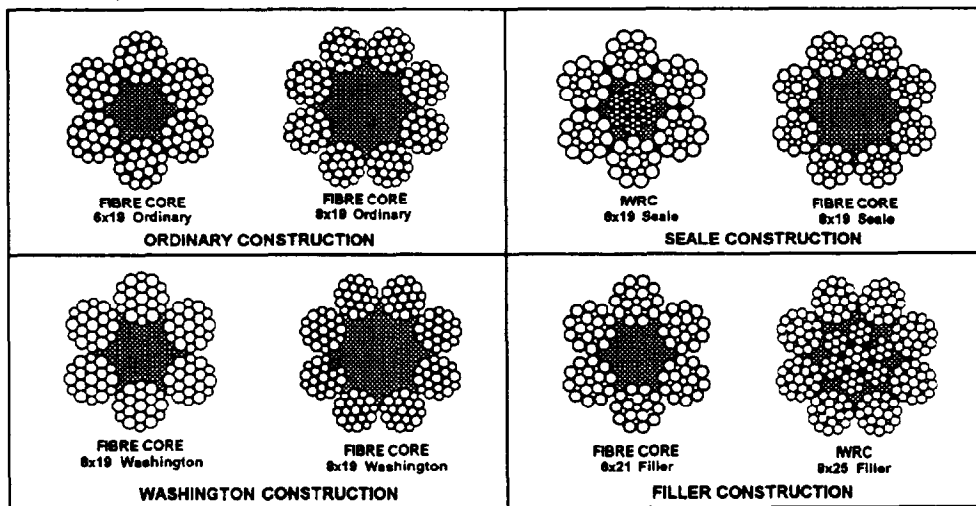

Figure 6-34.—Common strand construction.

- SEALE is where larger diameter wires are used on the outside of the strand to resist abrasion and smaller wires inside to provide flexibility.
- WARRINGTON is where alternate wires are large and small to combine great flexibility with resistance to abrasion.
- FILLER is where very small wires fill in the valleys between the outer and inner rows of wires to provide good abrasion and fatigue resistance.

**CORE.**—The wire rope core supports the strands laid around it. The three types of wire rope cores are fiber, wire strand, and independent wire rope (fig. 6-35).

- A fiber core may be a hard fiber, such as manila hemp, plastic, paper, or sisal. The fiber core offers the advantage of increased flexibility. It also serves as a cushion to reduce the effects of sudden strain and acts as an oil reservoir to lubricate the wire and strands (to reduce friction). Wire rope with a fiber core is used when flexibility of the rope is important.
- A wire strand core resists more heat than a fiber core and also adds about 15 percent to the strength of the rope; however, the wire strand core make the wire less flexible than a fiber core.
- An independent wire rope core is a separate wire rope over which the main strands of the rope are laid. This core strengthens the rope, provides support against crushing, and supplies maximum resistance to heat.

### Grades of Wire Rope

The three primary grades of wire rope are as follows:

- Mild plow steel wire rope is tough and pliable. It can stand repeated strain and stress and has a tensile strength (resistance to lengthwise stress) from 200,000 to 220,000 pounds per square inch

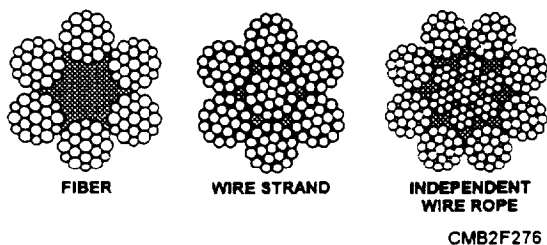

Figure 6-35.—Core construction.

(psi). These characteristics make it desirable for cable tool drilling and other purposes where abrasion is encountered.

- Plow steel wire rope is usually tough and strong. This steel has a tensile strength of 220,000 to 240,000 psi. Plow steel wire rope is suitable for hauling, hoisting, and logging.
- Improved plow steel wire rope is one of the best grades of rope available and is the most common rope used in the NCF. This type of rope is stronger, tougher, and more resistant to wear than the others. Each square inch of improved plow steel can stand a strain of 240,000 to 260,000 psi. This makes it especially useful for heavy-duty service, such as on cranes with excavating and weight-handling equipment.

### Lays of Wire Rope

The term *lay* refers to the direction of the twist of the wires in a strand and to the direction that the strands are laid in the rope. In some instances, both the wires in the strand and the strands in the rope are laid in the same direction; and, in other instances, the wires are laid in one direction and the strands are laid in the opposite direction, depending on the intended use of the rope. Most manufacturers specify the types and lays of wire rope to be used on their piece of equipment. Be sure and consult the operator's manual for proper application.

The five different lays used in wire rope are as follows (fig. 6-36):

- RIGHT REGULAR LAY has the wires in the strands laid to the left, while the strands are laid to the right to form the wire rope.
- LEFT REGULAR LAY has the wires in the strands laid to the right, while the strands are laid to the left to form the wire rope. In this lay, each step of fabrication is exactly opposite from the right regular lay.
- RIGHT LANG LAY has the wires in the strands and the strands in the rope laid to the right.
- LEFT LANG LAY has the wire in the strands and the strands in the rope laid to the left.
- REVERSE LAY has the wires in one strand laid to the right, the wire in the nearby strand are laid to the left, the wire in the next strand are to the right, and so forth, alternating direction from one strand to the other. Then all strands are laid to the right.

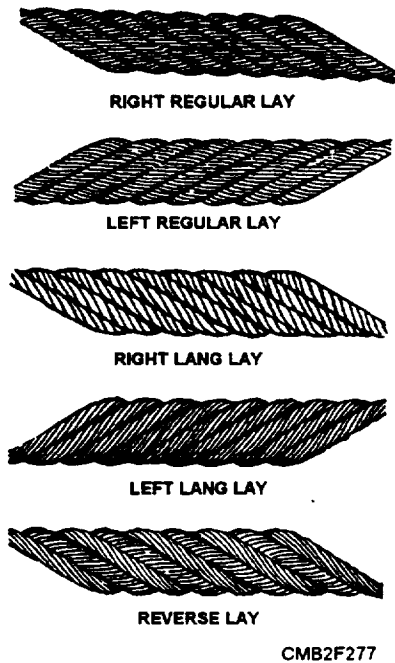

Figure 6-36.—Lays of wire rope.

### Characteristics of Wire Rope

The main types of wire rope used consist of 6, 7, 12, 19, 24, or 37 wires per strand. Usually, the wire rope has six strands laid around the core.

The two most common types of wire rope, 6 x 19 and 6 x 37, are shown in figure 6-37. The 6 x 19 type (having six strands with 19 wires in each strand) are the stiffest and strongest construction of the types of wire rope suitable for general hoisting operations. The 6 x 37 wire rope (six strands with 37 wires in each strand) are very flexible, making it suitable for cranes and similar equipment.

Several factors must be considered whenever a wire rope is selected for use in a particular kind of operation. The manufacture of wire rope which can withstand equally well all kinds of wear and stress, it

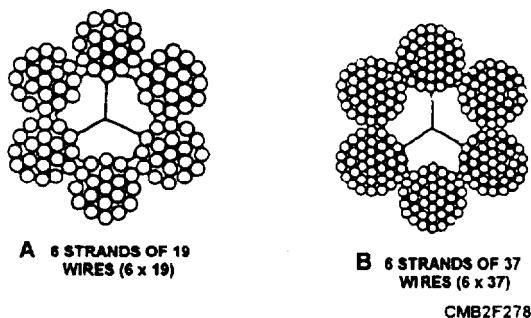

Figure 6-37.—A. 6 x 19 wire rope; B. 6 x 37 wire rope.

may be subjected to, is not possible. Because of this, selecting a rope is often a matter of compromise—sacrificing one quality to have some other more urgently needed characteristic.

**TENSILE STRENGTH.**—Tensile strength is the strength necessary to withstand a certain maximum load applied to the rope. It includes a reserve of strength measured in a so-called factor of safety.

**CRUSHING STRENGTH.**—Crushing strength is the strength necessary to resist the compressive and squeezing forces that distort the cross section of a wire rope, as it runs over sheaves, rollers, and hoist drums when under a heavy load. Regular lay rope distorts less in these situations than lang lay.

**FATIGUE RESISTANCE.**—Fatigue resistance is the ability to withstand the constant bending and flexing of wire rope that runs continuously on sheaves and hoist drums. Fatigue resistance is important when wire rope must run at high speeds. Such constant and rapid bending of the rope can break individual wires in the strands. Lang lay ropes are best for service requiring high fatigue resistance. Ropes with similar wires around the outside of their strands also have a greater resistance, since these strands are more flexible.

**ABRASION RESISTANCE.**—Abrasion resistance is the ability to withstand the gradual wearing away of the outer metal, as the rope runs across sheaves and hoist drums. The rate of abrasion depends mainly on the load carried by the rope and its running speed. Generally, abrasion resistance in a rope depends on the type of metal of which the rope is made and the size of the individual outer wires. Wire rope made of harder steels, such as improved plow steel, has a considerable resistance to abrasion. Ropes that have larger wires forming the outside of their strands are more resistant to wear than rope having smaller wires which wear away more quickly.

**CORROSION RESISTANCE.**—Corrosion resistance is the ability to withstand the dissolution of the wire metal that results from chemical attack by moisture in the atmosphere or elsewhere in the working environment. Ropes that are put to static work, such as guy wires, may be protected from corrosive elements by paints or other special dressings. Wire rope may be galvanized for corrosion protection. Most wire rope used in crane operations must rely on their lubricating dressing to double as a corrosion preventive.

## Measuring Wire Rope

Wire rope is designated by its diameter in inches, as shown in figure 6-38. The correct methods of measuring wire rope is to measure from the top of one strand to the top of the strand directly opposite it. The wrong way is to measure across two strands side by side.

To ensure an accurate measurement of the diameter of a wire rope, always measure the rope at three places at least 5 feet apart. Use the average of the three measurements as the diameter of the rope.

## Wire Rope Safe Working Load

The term safe working load (SWL) of wire rope means the load that can be applied and still obtain the most efficient service and also prolong the life of the rope. For the safe working load of wire rope, refer to the manufacturer's certification of published breaking strength or the actual breaking strength of a piece of wire rope taken from the reel and tested.

## Wire Rope Failure

Some of the common causes of wire rope failure are the following:

- Using incorrect size, construction, or grade
- Dragging over obstacles
- Lubricating improperly
- Operating over sheaves and drums of inadequate size
- Overriding or cross winding on drums
- Operating over sheaves and drums with improperly fitted grooves or broken flanges

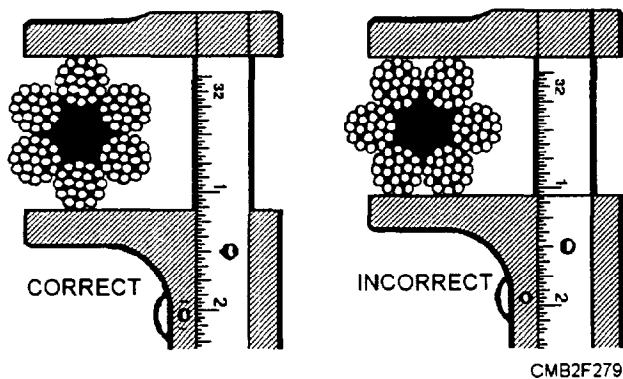

Figure 6-38.—Correct and incorrect methods of measuring wire rope.

- Jumping of sheaves
- Exposing to acid or corrosive liquid or gases
- Using an improperly attached fitting
- Allowing grit to penetrate between the strands promoting internal wear
- Subjecting to severe or continuing overload
- Using an excessive fleet angle

## Handling and Care of Wire Rope

To render safe, dependable service over a maximum period of time, you should take good care and upkeep that is necessary to keep wire rope in good condition. Various ways of caring for and handling wire rope are described below.

**COILING AND UNCOILING.**—Once a new reel has been opened, it may be coiled or faked down, like line. The proper direction of coiling is counterclockwise for left lay and clockwise for right lay wire rope. Because of the general toughness and resilience of wire, it tends now and then to resist being coiled down. When this occurs, it is useless to fight the wire by forcing down the turn because it will only spring up again. But if it is thrown in a back turn, as shown in figure 6-39, it will lie down properly. A wire rope, when faked down, will run right off, like line; but when wound in a coil, it must always be unwound.

Wire rope tends to kink during uncoiling or unreeling, especially if it has been in service long. A kink can cause a weak spot in the rope that wears out quicker than the rest of the rope.

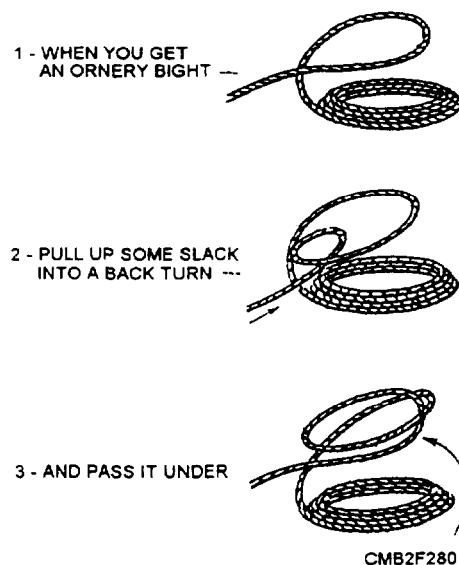

Figure 6-39.—Throwing a back turn.

A good method for unreeling wire rope is to run a pipe or rod through the center and mount the reel on drum jacks or other supports so the reel is off the ground, as shown in figure 6-40. In this way, the reel will turn as the rope is unwound, and the rotation of the reel helps keep the rope straight. During unreeling, pull the rope straightforward, and avoid hurrying the operation. As a safeguard against kinking, NEVER unreel wire rope from a reel that is stationary.

To uncoil a small coil of wire rope, simply stand the coil on edge and roll it along the ground like a wheel, or hoop, as also shown in figure 6-40. NEVER lay the coil flat on the floor or ground and uncoil it by pulling on the end, because such practice can kink or twist the rope.

**KINKS.**—One of the most common forms of damage resulting from improperly handled wire rope is the development of a kink. A kink starts with the formation of a loop, as shown in figures 6-41 and 6-42.

A loop that has not been pulled tight enough to set the wires or strands or the rope into a kink can be removed by turning the rope at either end in the proper direction to restore the lay (fig. 6-43). If this is not done and the loop is pulled tight enough to cause a kink (fig. 6-44), the kink will result in irreparable damage to the rope (fig. 6-45).

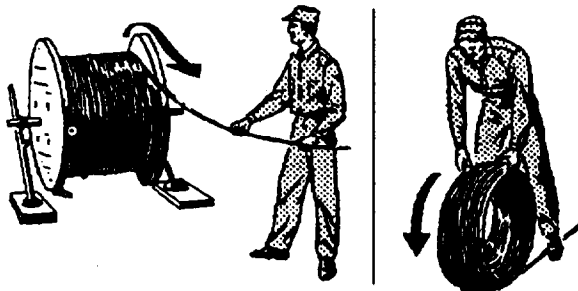

Figure 6-40.—Unreeling wire rope (left); uncoiling wire rope (right).

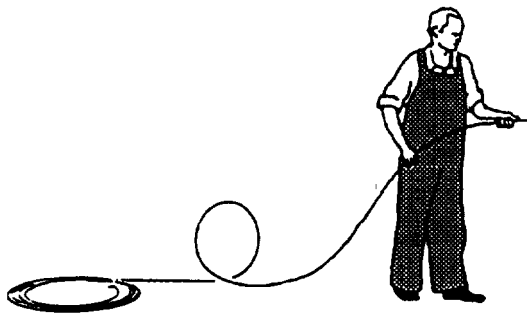
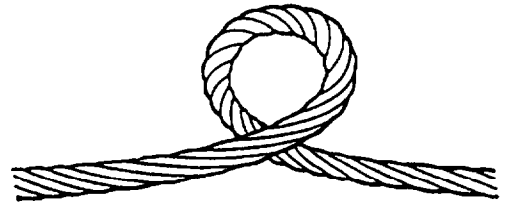
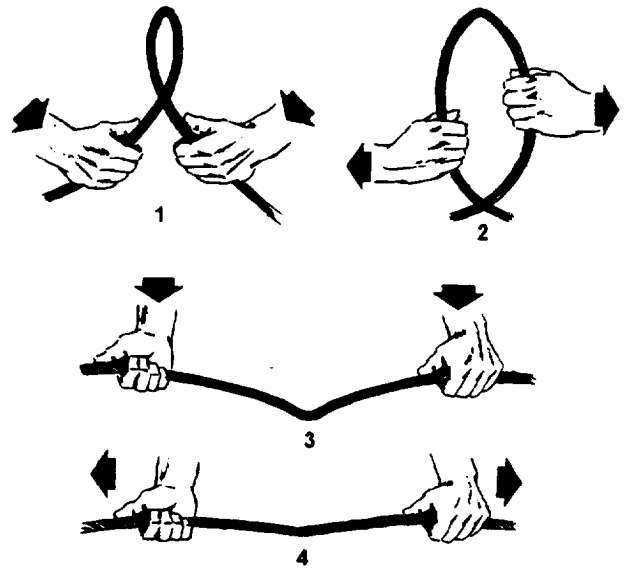

Figure 6-41.—Improper handling.



CMB2F283

Figure 6-42.—Wire rope loop.



CMB2F284

Figure 6-43.—The correct way to take out a loop in a wire rope.



CMB2F285

Figure 6-44.—Wire rope kink.



CMB2F286

Figure 6-45.—Kink damage.

Kinking can be prevented by proper uncoiling and unreeling methods and by the correct handling of the rope throughout its installation.

**DRUM WINDING.**—Spooling wire rope on a crane hoist drum causes a slight rotating tendency of the rope due to the spiral lay of the strands. Two types

of hoist drums used for spooling wire rope are as follows:

1. Grooved drum. When grooved drums are used, the grooves generally give sufficient control to wind the wire rope properly, whether it is right or left lay rope.
2. Smooth-faced drum. Smooth-faced drums are used where the only other influence on the wire rope is winding on the first layer is the fleet angle. The slight rotational tendency of the rope can be used as an advantage in keeping the winding tight and uniform.

**NOTE**

Using the wrong type of wire rope lay causes the rotational tendency of the rope to be a disadvantage, because it results in loose and nonuniform winding of the rope on the hoist drum.

Figure 6-46 shows drum-winding diagrams for selection of the proper lay of rope. Standing behind the hoist drum and looking towards an oncoming

overwind rope, the rotating tendency of right lay rope is toward the left; whereas the rotating tendency of a left lay rope is to the right.

Refer to figure 6-46. With overwind reeving and a right lay rope on a smooth-faced drum, the wire rope bitter end attachment to the drum flange should be at the left flange. With underwind reeving and a right lay rope, the wire rope bitter end should be at the right flange.

When wire rope is run off one reel onto another or onto a winch or drum, it should be run from TOP TO TOP or from BOTTOM TO BOTTOM, as shown in figure 6-47.

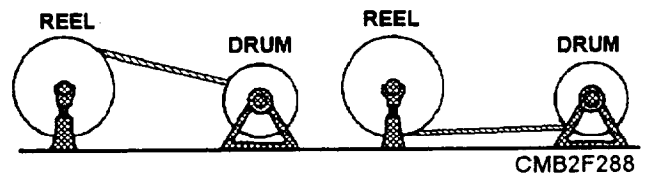
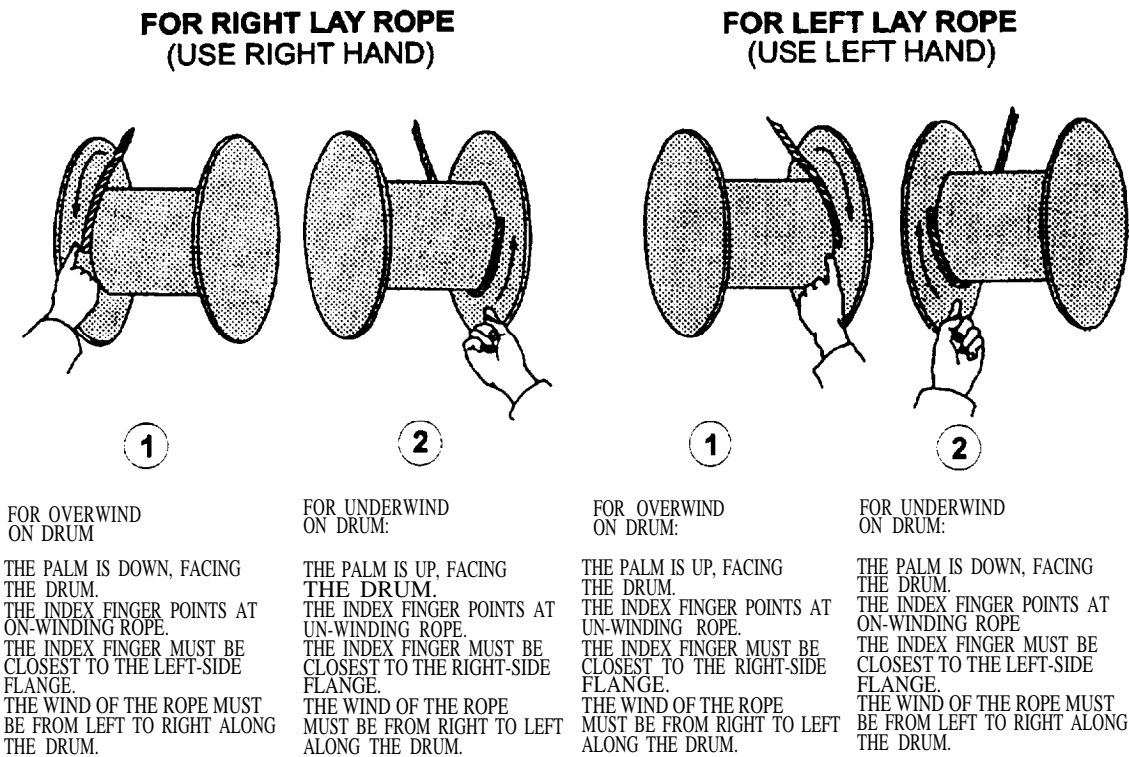

Figure 6-47.—Transferring wire rope from reel to drum.



IF A SMOOTH-FACE DRUM HAS BEEN CUT OR SCORED BY AN OLD ROPE, THE METHODS SHOWN MAY NOT APPLY.

CMB2F287

Figure 6-46.—Different lays of wire rope winding on hoisting drums.

**FLEET ANGLE.**—The fleet angle is formed by running wire rope between a sheave and a hoist drum whose axles are parallel to each other (fig. 6-48). Too large a fleet angle can cause the wire rope to climb the flange of the sheave and can also cause the wire rope to climb over itself on the hoist drum.

**SIZES OF SHEAVES.**—The diameter of a sheave should never be less than 20 times the diameter of the wire rope. An exception is 6 x 37 wire for which a smaller sheave can be used, because it is more flexible.

**REVERSE BENDS.**—Whenever possible, drums, sheaves, and blocks used with wire rope should be placed to avoid reverse or S-shaped bends. Reverse bends cause the individual wires or strands to shift too much and increase wear and fatigue. For a reverse bend, the drums and blocks affecting the reversal should be of a larger diameter than ordinarily used and should be spaced as far apart as possible.

**SEIZING AND CUTTING.**—The makes of wire rope are careful to lay each wire in the strand and each strand in the rope under uniform tension. If the ends of the rope are not secured properly, the original balance of tension will be disturbed. Maximum service is not obtainable because some strands can carry a greater portion of the load than others can. Before cutting steel wire rope, place seizing on each side of the point where the rope is to be cut.

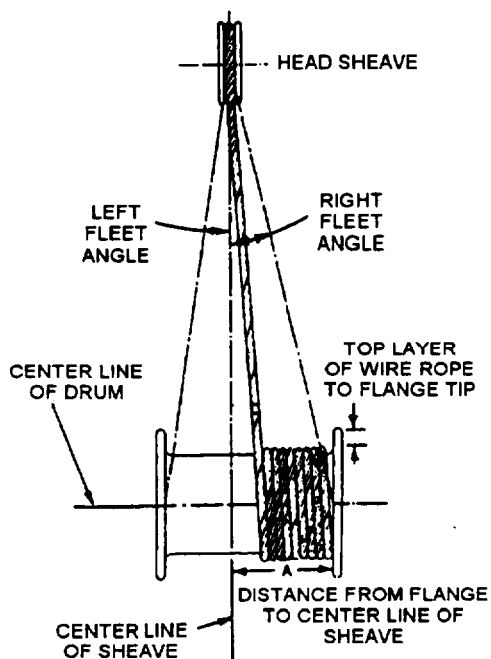

CMB2F289

Figure 6-48.—Fleet angle relationship.

A rule of thumb for determining the size, number, and distance between seizing is as follows:

- The number of seizing to be applied equals approximately three times the diameter of the rope.

Example: 3 x 3/4-inch-diameter rope = 2 1/4 inches. Round up to the next higher whole number and use three seizing.

- The width of each seizing should be 1 to 1 1/2 times as long as the diameter of the rope.

Example: 1 x 3/4-inch-diameter rope = 3/4 inch. Use a 1-inch width of seizing.

- The seizing should be spaced a distance equal to twice the diameter of the wire rope.

Example: 2 x 3/4-inch-diameter rope = 1 1/2 inches. Space the seizing 2 inches apart.

A common method used to make a temporary wire rope seizing is as follows (fig. 6-49):

Wind the seizing wire uniformly, using tension on the wire. After making the required number of turns, as shown in step 1, twist the ends of the wires counterclockwise by hand, so the twisted portion of the wires is near the middle of the seizing, as shown in step 2.

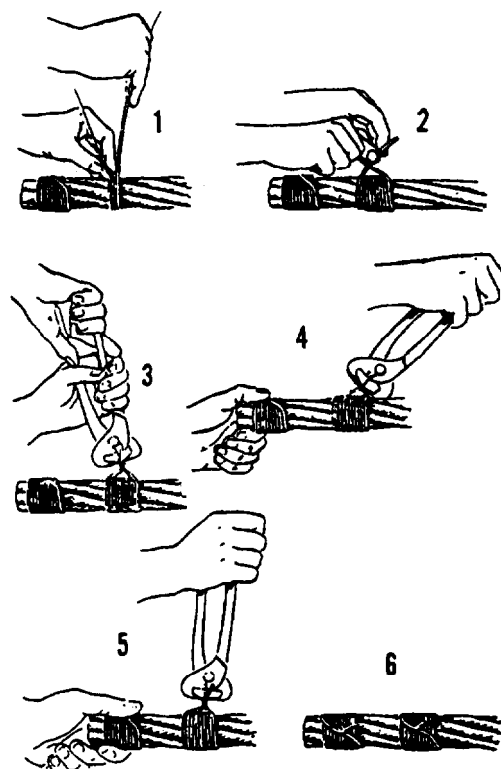

CMB2F290

Figure 6-49.—Seizing wire rope.

Grasp the ends with end-cutting nippers and twist up slack, as shown in step 3. Do not try to tighten the seizing by twisting. Draw up on the seizing, as shown in step 4. Again twist up the slack, using the nippers as shown in step 5. Repeat steps 4 and 5 as needed. Cut the ends and pound them down on the rope, as shown in step 6. If the seizing is to be permanent, use a serving bar, or iron, to increase tension on the seizing wire when putting on the turns.

Wire rope can be cut successfully by a number of methods. An effective and simple method is to use a hydraulic type of wire rope cutter, as shown in figure 6-50. Remember that all wire should be seized before it is cut. For best results in using this method, place the rope in the cutter so the blade comes between the two central seizing. With the release valve closed, jack the blade against the rope at the location of the cut and continue to operate the cutter until the wire rope is cut.

When a hydraulic type of wire cutter is NOT available, other methods can be used, such as a hammer-type wire rope cutter (fig. 6-51), a cutting torch, and, if need be, a hacksaw and cold chisel.

### Wire Rope Maintenance

Wire rope bending around hoist drums and sheaves will wear like any other metal article, so lubrication is just as important to an operating wire rope as it is to any other piece of working machinery.

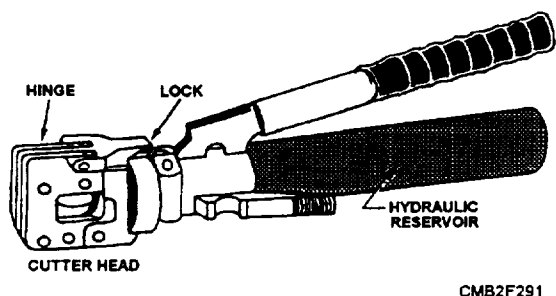

Figure 6-50.—Hydraulic type of wire cutter.

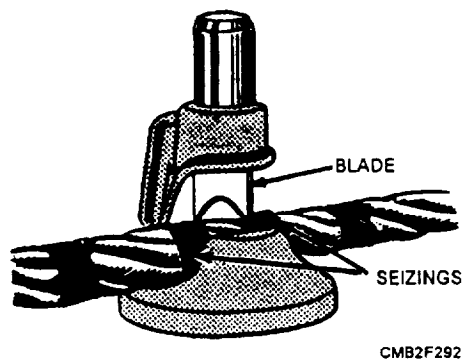

Figure 6-51.—Hammer-type wire rope cutter.

For wire rope to work right, its wires and strands must be free to move. Friction from corrosion or lack of lubrication shortens the service life of wire rope.

Deterioration from corrosion is more dangerous than that from wear because corrosion ruins the inside wires—a process hard to detect by inspection. Deterioration caused by wear can be detected by examining the outside wires of the rope, because these wires become flattened and reduced in diameter, as the wire rope wears.

### NOTE

Replace wire rope that has one third of the original diameter of the outside individual wires.

Both internal and external lubrication protects a wire rope against wear and corrosion. Internal lubrication can be properly applied only when the wire rope is being manufactured, and manufacturers customarily coat every wire with a rust-inhibiting lubricant, as it is laid into the strand. The core is also lubricated in manufacturing.

Lubrication that is applied in the field is designed not only to maintain surface lubrication but also to prevent loss of internal lubrication provided by the manufacturer. The Navy issues an asphaltic petroleum oil that must be heated before using. This lubricant is known as Lubricating Oil for Chain, Wire Rope, and Exposed Gear and comes in two types:

- Type I, Regular: Does not prevent rust and is used where rust prevention is not needed; for example, elevator wires used inside are not exposed to the weather but need lubrication.
- Type II, Protective: A lubricant and an anticorrosive—it comes in three grades: grade A, for cold weather (60°F and below); grade B, for warm weather (between 60°F and 80°F); and grade C, for hot weather (80°F and above).

The oil, issued in 25-pound and 35-pound buckets and in 100-pound drums, can be applied with a stiff brush, or the wire rope can be drawn through a trough of hot lubricant (fig. 6-52). The frequency of application depends upon service conditions; as soon as the last coating has appreciably deteriorated, it should be renewed. A good lubricant to use when working in the field, as recommended by COMSECOND/COMTHRIDNCBINST 11200.11, is a mixture of new motor oil and diesel fuel at a ratio of 70-percent oil and 30-percent diesel fuel.



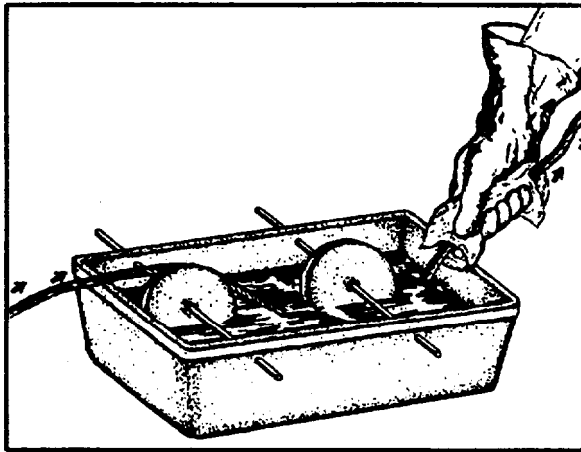

CMB2F293

Figure 6-52.—Trough method of lubricating wire rope.

### CAUTION

Avoid prolonged skin contact with oils and lubricants. Consult the Materials Safety Data Sheets (MSDS) on each item before use for precautions and hazards. See your supervisor for copies of MSDSs.

As a safety precaution, always wipe off any excess oil when lubricating wire rope especially with hoisting equipment. Too much lubricant can get into brakes or clutches and cause them to fail. While in use, the motion of machinery may sling excess oil around over cranes cabs and onto catwalks making them unsafe.

### NOTE

Properly dispose of wiping rags and used or excess lubricants as hazardous waste. See your supervisor for details on local disposal requirements.

### Wire Rope Attachments

Attachments are fitted to the ends of wire rope, so the rope can be connected to other wire ropes, pad eyes, or equipment. The common attachments used are the wedge socket, the speltered socket, wire rope clips, the thimble, swaged connections, and hooks and shackles.

**WEDGE SOCKET.**—The attachment used most often to attach dead ends of wire ropes to pad eyes or like fittings on cranes and earthmoving equipment is the wedge socket (fig. 6-53). The socket is applied to the bitter end of the wire rope.

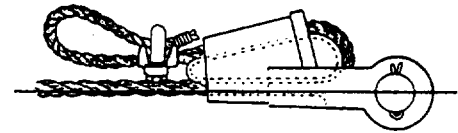

CMB2F294

Figure 6-53.—Wedge socket.

### NOTE

The wedge socket develops only 70 percent of the breaking strength of the wire rope due to the crushing action of the wedge.

**SPELTERED SOCKET.**—Spelting is the best way to attach a closed or open socket in the field. "Spelting" means to attach the socket to the wire rope by pouring hot zinc around it, as shown in figure 6-54. Spelting should be done by qualified personnel.

Forged steel speltered sockets are as strong as the wire rope itself. Speltered sockets are required on all cranes used to lift personnel, ammunition, acids, and other dangerous materials.

### NOTE

Spelter sockets develop 100 percent of the breaking strength of the wire rope.

**WIRE ROPE CLIPS.**—Wire rope clips are used to make eyes in wire rope, as shown in figure 6-55. The U-shaped part of the clip with the threaded ends is called the U-bolt; the other part is called the saddle. The saddle is stamped with the diameter of the wire rope that the clip will fit. Always place a clip with the

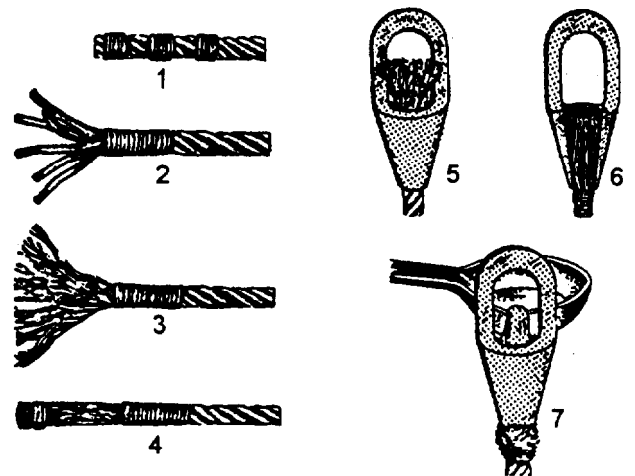

CMB2F295

Figure 6-54.—Spelting a socket.

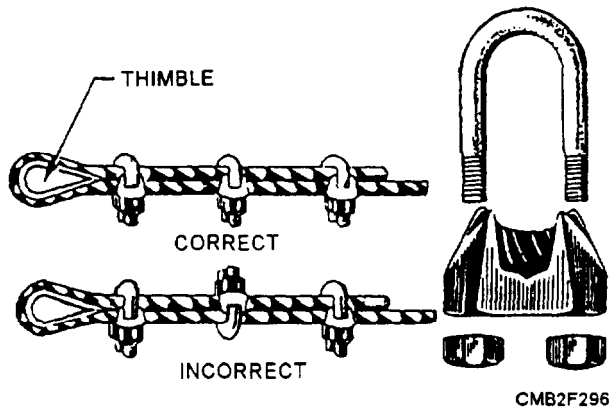

Figure 6-55.—Wire rope clips.

U-bolt on the bitter (dead) end, not on the standing part of the wire rope. If clips are attached incorrectly, the standing part (live end) of the wire rope will be distorted or have mashed spots. A rule of thumb when attaching a wire rope is to NEVER saddle a dead horse.

Two simple formulas for figuring the number of wire rope clips needed are as follows:

- $3 \times \text{wire rope diameter} + 1 = \text{Number of clips}$
- $6 \times \text{wire rope diameter} = \text{Spacing between clips}$

Another type of wire rope clip is the twin-base clip, often referred to as the universal or two clamp (fig. 6-56). Both parts of this clip are shaped to fit the wire rope, so the clip cannot be attached incorrectly. The twin-base clip allows for a clear 360-degree swing with the wrench when the nuts are being tightened.

**THIMBLE.**—When an eye is made in a wire rope, a metal fitting, called a thimble, is placed in the eye, as shown in figure 6-55. The thimble protects the eye against wear. Wire rope eyes with thimbles and wire rope clips can hold approximately 80 percent of the wire rope strength.

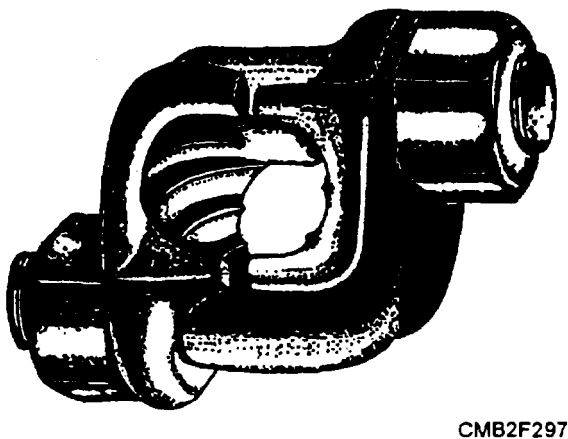

Figure 6-56.—Twin-base wire rope clip.

After the eye made with clips has been strained, the nuts on the clips must be re-tightened. Checks should be made now and then for tightness or the clips will cause damage to the rope.

**SWAGED CONNECTIONS.**—Swaging makes an efficient and permanent attachment for wire rope, as shown in figure 6-57. A swaged connection is made by compressing a steel sleeve over the rope by using a hydraulic press. When the connection is made properly, it provides 100 percent capacity of the wire rope.

Careful inspection of the wires leading into these connections is important because of the pressure put upon the wires in this section. If one broken wire is found at the swaged connection or a crack in the swage, replace the fitting.

**HOOKS AND SHACKLES.**—Hooks and shackles are handy for hauling or lifting loads without tying them directly to the object with line, wire rope, or chain. They can be attached to wire rope, fiber line, blocks, or chains. Shackles should be used for loads too heavy for hooks to handle.

When hooks fail due to overloading, they usually straighten out and lose or drop their load. When a hook has been bent by overloading, it should NEVER be straightened and put back into service. It should be cut in half with a cutting torch and discarded.

Hooks should be inspected at the beginning of each workday and before lifting a full-rated load. If you are not sure a hook is strong enough to lift the load, by all means use a shackle.

Hooks that close and lock should be used where there is a danger of catching *on* an obstruction, particularly in hoisting buckets, cages, or skips, and especially in shaft work. Hooks and rings used with a chain should have about the same strength as the chain.

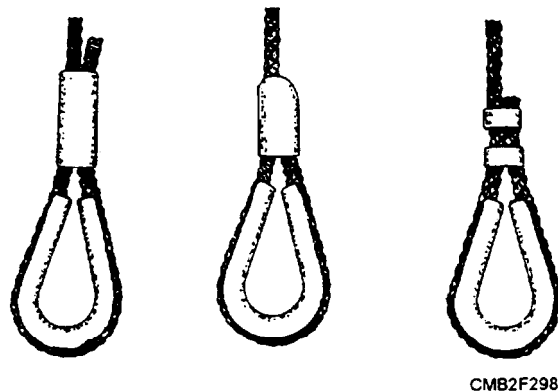

Figure 6-57.—Swaged connections.

The manufacturer's recommendations should be followed in determining the safe working loads of the various sizes and types of specific and identifiable hooks. All hooks for which no applicable manufacturer's recommendations are available should be tested to twice the intended safe working load before they are initially put into service.

Mousing is a technique often used to close the open section of a hook to keep slings, straps, and similar attachments from slipping off the hook, as shown in figure 6-58.

Hooks may be moused with rope yarn, seizing wire, or a shackle. When using rope yarn or wire, make 8 to 10 wraps around both sides of the hook. To finish off, make several turns with the yarn or wire around the sides of the mousing, and then tie the ends securely.

Two types of shackles used in rigging are the anchor (fig. 6-59) and the chain (fig. 6-60). Both are available with screw pins or round pins.

Shackles should be used in the same configuration as they were manufactured. All pins must be straight and cotter pins must be used or all screw pins must be seated. When the original pin is lost or does not fit properly, do not use the shackle. Never replace the shackle pin with a bolt.

A shackle should never be pulled from the side. This causes the shackle to bend reducing its capacity tremendously. Always attach a screw pin shackle with the screw pin on the dead end of the rope. If placed on the running end, the movement of the rope may loosen the pin.

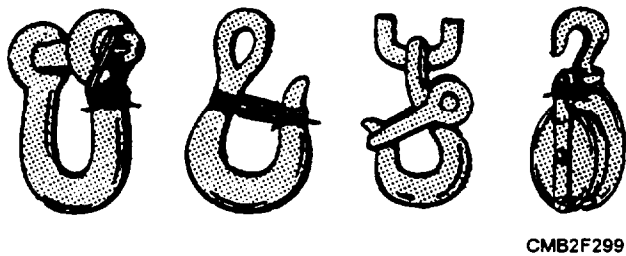
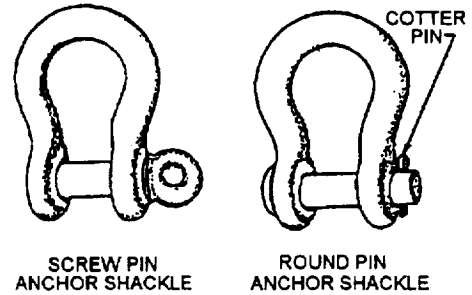
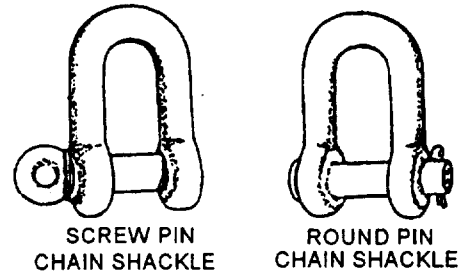

Figure 6-58.—Mousing.



CMB2F300

Figure 6-59.—Anchor shackles.



CMB2F301

Figure 6-60.—Chain shackles.

Shackles are moused whenever there is a chance of the shackle pin working loose and coming out due to vibration. To mouse a shackle, simply take several turns with seizing wire through the eye of the pin and around the bow of the shackle. Refer to figure 6-58 for proper mousing.

### REVIEW 3 QUESTIONS

- Q1. What are the two types of brakes used on a jaw-clutch type winch?
- Q2. What device is used on a winch to prevent crushing of the cable due to loose crossed coils and layers?
- Q3. Wire rope is composed of what total number of parts?
- Q4. What is the most common type of wire rope used by the NCF?
- Q5. What is the recommended ratio of new oil to diesel for the lubrication of wire rope?

### **REVIEW 1 ANSWERS**

- Q1. Two forward and two reverse speeds*
- Q2. Forward clutch shaft*
- Q3. Pump-motor team*
- Q4. Charge pump*
- Q5. Variable displacement*

### **REVIEW 2 ANSWERS**

- Q1. Pins and bushings*
- Q2. Ruler and tape measure*
- Q3. Grouser*
- Q4. Front idler*
- Q5. Rear guiding guards*

### **REVIEW 3 ANSWERS**

- Q1. Worm shaft brake and shifter bracket brake*
- Q2. Automatic level winding device*
- Q3. Three*
- Q4. Improved plow steel wire rope*
- Q5. 70 percent new oil to 30 percent diesel*

# CHAPTER 7

## BRAKES

### INTRODUCTION

**Learning Objective:** Explain the hydraulic and mechanical principles of a brake system. Describe and define the major components of hydraulic, air, and air-over-hydraulic brake systems. Explain the operation of hydraulic, air, and air-over-hydraulic brake systems. Summarize the operation of antilock braking systems.

The brake system is the most important system on a vehicle from a safety standpoint. You, as the mechanic, are trusted to do every service and repair operation correctly. When working on a brake system, always keep in mind that a brake system failure could result in a fatal vehicle accident. It is up to you to make sure the vehicle brake system is in perfect operating condition before the vehicle leaves the shop.

Braking action is the use of a controlled force to accomplish three basic tasks—to slow down, stop, or hold the wheels of a vehicle stationary. Braking action is accomplished by rubbing two surfaces together that cause friction and heat (fig. 7-1). Friction is the resistance to relative motion between two surfaces in contact. The brakes convert kinetic (moving) energy into heat to stop the vehicle. Heat energy is an unwanted product of friction and must be dissipated to the surrounding environment as efficiently as possible.

### HYDRAULIC BRAKE SYSTEM

**Learning Objective:** Describe the operation, terms, and component functions of a hydraulic brake system. Describe the procedures for servicing a hydraulic brake system.

In hydraulic braking systems, the pressure applied at the brake pedal is transmitted to the brake

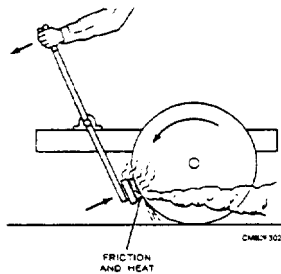

Figure 7-1.—Development of friction and heat.

mechanism by a liquid. To understand how pressure is transmitted by a hydraulic braking system, it is necessary to understand the fundamentals of hydraulics (refer to chapter 3 of this TRAMAN). There are two common types of hydraulic brake systems used on modern vehicles—drum and disc brakes.

### PRINCIPLES OF BRAKING

It is known that to increase the speed of a vehicle requires an increase in the power output of the engine. It is also true, although not so apparent, that an increase in speed requires an increase in the braking action to bring a vehicle to a stop (fig. 7-2). A moving vehicle, just as any other moving body, has what is known as kinetic energy. Kinetic energy is the energy an object possesses due to its relative motion. This kinetic energy, which increases with speed, must be overcome by braking action. If the speed of the vehicle is doubled, its kinetic energy is increased fourfold; therefore, four times as much energy must be overcome by the braking action.

Brakes must not only be capable of stopping a vehicle but must stop in as short a distance as possible. Because brakes are expected to decelerate a vehicle at a faster rate than the engine can accelerate, they must be able to control a greater power than that developed

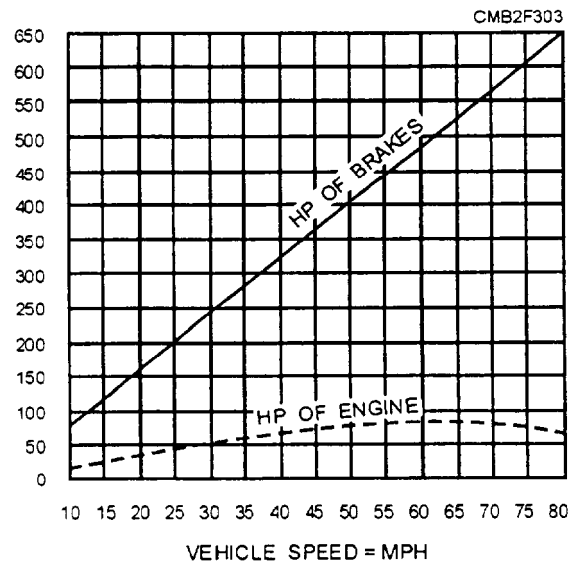

Figure 7-2.—Braking requirements.

by the engine. This is the reason that well-designed, powerful brakes have to be used to control the modern high-speed vehicle.

It is possible to accelerate an average vehicle with an 80 horsepower engine from a standing start to 80 mph in about 36 seconds. By applying the full force of the brakes, such a vehicle can be decelerated from 80 mph to a full stop in about 4.5 seconds. The time required to decelerate to a stop is one eighth of the time required to accelerate from a standing start. Therefore, the brakes harness eight times the power developed by the engine. Thus about 640 (8 x 80) horsepower has to be spent by the friction surfaces of the brakes of an average vehicle to bring it to a stop from 80 mph in 4.5 seconds.

### Vehicle Stopping Distance

Operator reaction time is the time frame between the instant the operator decides that the brakes should be applied and the moment the brake system is activated. During the time that the operator is thinking about applying the brakes and moving his or her foot to do so, the vehicle will travel a certain distance depending on the speed of the vehicle. After the brakes are applied, the vehicle will travel an additional distance before it is brought to a stop.

Total stopping distance of a vehicle is the total of the distance covered during the operator's reaction time and the distance during which the brakes are applied before the vehicle stops. Figure 7-3 shows the total stopping distance required at various vehicle speeds, assuming the average reaction time of 3/4 second and that good brakes are applied under most favorable road conditions.

### Braking Temperature

Brakes are devices that convert the energy of a moving vehicle into heat whenever the brakes are applied. This heat must be absorbed and dissipated by the brake parts. Unless the heat is carried away as fast as it is produced, brake part temperatures will rise.

Since the heat generated by brake applications usually is greater than the rate of heat dissipation, high brake temperatures result. Ordinarily, the time interval between brake applications avoids a heat buildup. If, however, repeated panic stops are made, temperatures become high enough to damage the brake linings, brake drums, brake fluid, and, in some extreme cases, even tires have been set on fire.

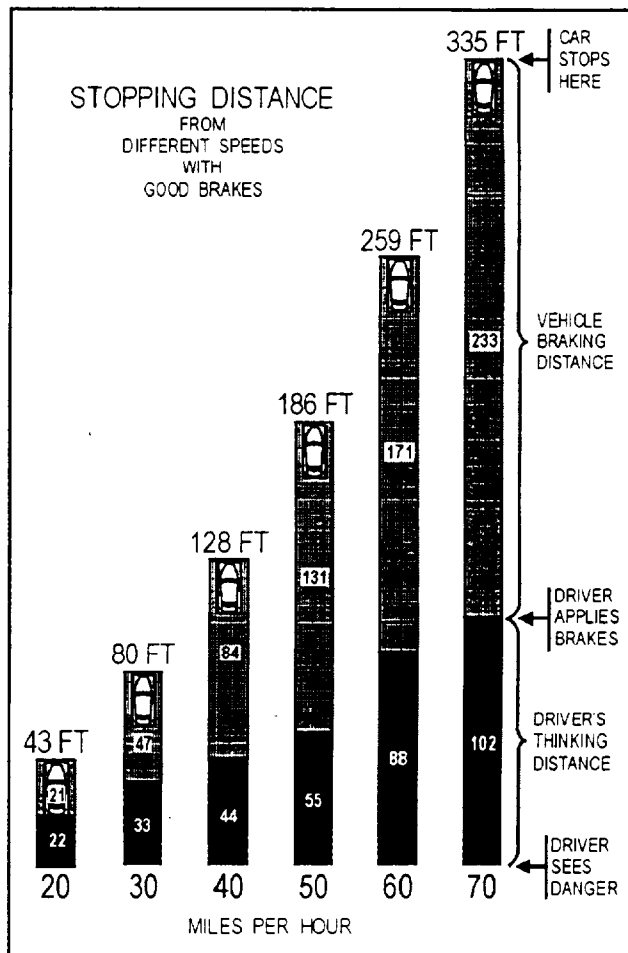

CMB2F304

Figure 7-3.—Total vehicle stopping distance of an average vehicle.

Factors that tend to increase brake temperatures include the following:

- Load on the vehicle
- Operator abuse
- Speed of the vehicle
- Maladjustment of brakes
- Incorrect installation of brake parts
- Unbalanced braking

If road speeds are increased and/or more weight is placed in the vehicle, brake temperatures increase. In fact, under extreme conditions of unbalanced brakes on a heavy truck making an emergency stop from high speed, enough heat is generated to melt a cube of iron weighing 11.2 pounds.

## Braking Ratio

Braking ratio refers to the comparison of front-wheel to rear-wheel braking effort. When a vehicle stops, its weight tends to transfer to the front wheels. The front tires are pressed against the road with greater force. The rear tires lose some of their grip on the road. As a result, the front wheels do more of the braking than the rear.

For this reason, many vehicles have disc brakes on the front and drum brakes on the rear. Disc brakes are capable of producing more stopping effort than drum brakes. If drum brakes are used on both the front and rear wheels, the front shoe linings and drums typically have a larger surface area.

Typically, front-wheel brakes handle 60 to 70 percent of the braking power. Rear wheels handle 30 to 40 percent of the braking. Front-wheel drive vehicles, having even more weight on the front wheels, have even a higher braking ratio at the front wheels.

## HYDRAULIC SYSTEM

The hydraulic system applies the brakes at all four wheels with equalized pressure. It is pedal operated. The system consists of the master cylinder, the wheel cylinder, the brake lines and hoses, and the brake fluid.

### Master Cylinder

The master cylinder is the primary unit in the brake system that converts the force of the operator's foot into fluid pressure to operate the wheel cylinders. It is normally mounted to the firewall, which allows for easy inspection and service, and is less prone to dirt

and water. The master cylinder has four basic functions that are as follows:

- It develops pressure, causing the wheel cylinder pistons to move towards the drum or rotor.
- After all of the shoes or pads produce sufficient friction, the master cylinder assists in equalizing the pressure required for braking.
- It keeps the system full of fluid as the brake linings wear.
- It can maintain a slight pressure to keep contaminants (air and water) from entering the system.

In its simplest form, a master cylinder consists of a housing, a reservoir, a piston, a rubber cup, a return spring, a rubber boot, and a residual pressure check valve (fig. 7-4). There are two ports (inlet port and compensating port) drilled between the cylinder and reservoir. The description of the components of a master cylinder is as follows:

- The master cylinder housing is an aluminum or iron casting having either an integral or detachable reservoir. A cylinder is machined in the housing of the master cylinder. The spring, the cups, and the metal piston move within this cylinder.
- The piston is a long spoonlike member with a rubber secondary cup seal at the outer end and a rubber primary cup at the inner end, which are used to pressurize the brake system. The primary cup is held against the end of the piston by the return spring. A steel stop disc, held in the outer end of the cylinder by a retainer spring, acts as a piston stop.

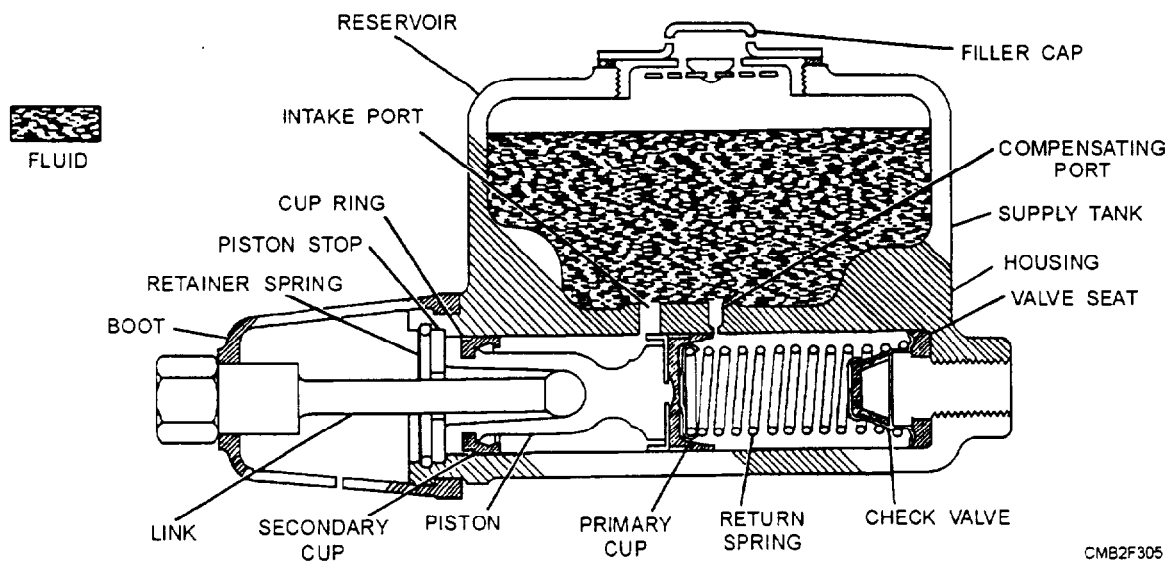

Figure 7-4.—Cutaway view of a single master cylinder.

A rubber boot prevents dust, dirt, and moisture from entering the back of the master cylinder. The boot fits over the master cylinder housing and the brake pedal pushrod.

- The reservoir carries a sufficient reserve of fluid to allow for expansion and contraction of brake fluid and brake lining wear. The reservoir is filled at the top and is well sealed by a removable filler cap containing a vent. Integral reservoirs are made of the same material as the cylinder, whereas detachable reservoirs are made of plastic.

- The intake port or vent allows fluid to enter the rear of the cylinder, as the piston moves forward. Fluid flows out of the reservoir, through the intake port, and into the area behind the piston and cup.

- The compensating port releases extra pressure when the piston returns to the released position. Fluid can flow back into the reservoir through the

compensating port. The action of both ports keeps the system full of fluid.

- The residual pressure check valve maintains residual fluid pressure of approximately 10 psi. This pressure prevents fluid from seeping past the cups in the wheel cylinders and also prevents air from entering the hydraulic passages when the brakes are released.

Older vehicles used single piston, single reservoir master cylinders that were dangerous. If a fluid leak developed (cracked brake hose, seal damage, or line rupture), a sudden loss of braking ability occurred. Modern vehicles use dual master cylinders. These master cylinders provide an additional safety feature in that should one portion of the brake system fail, the other system will allow the vehicle to maintain some braking ability.

The dual master cylinder (fig. 7-5), also called a tandem master cylinder, has two separate hydraulic

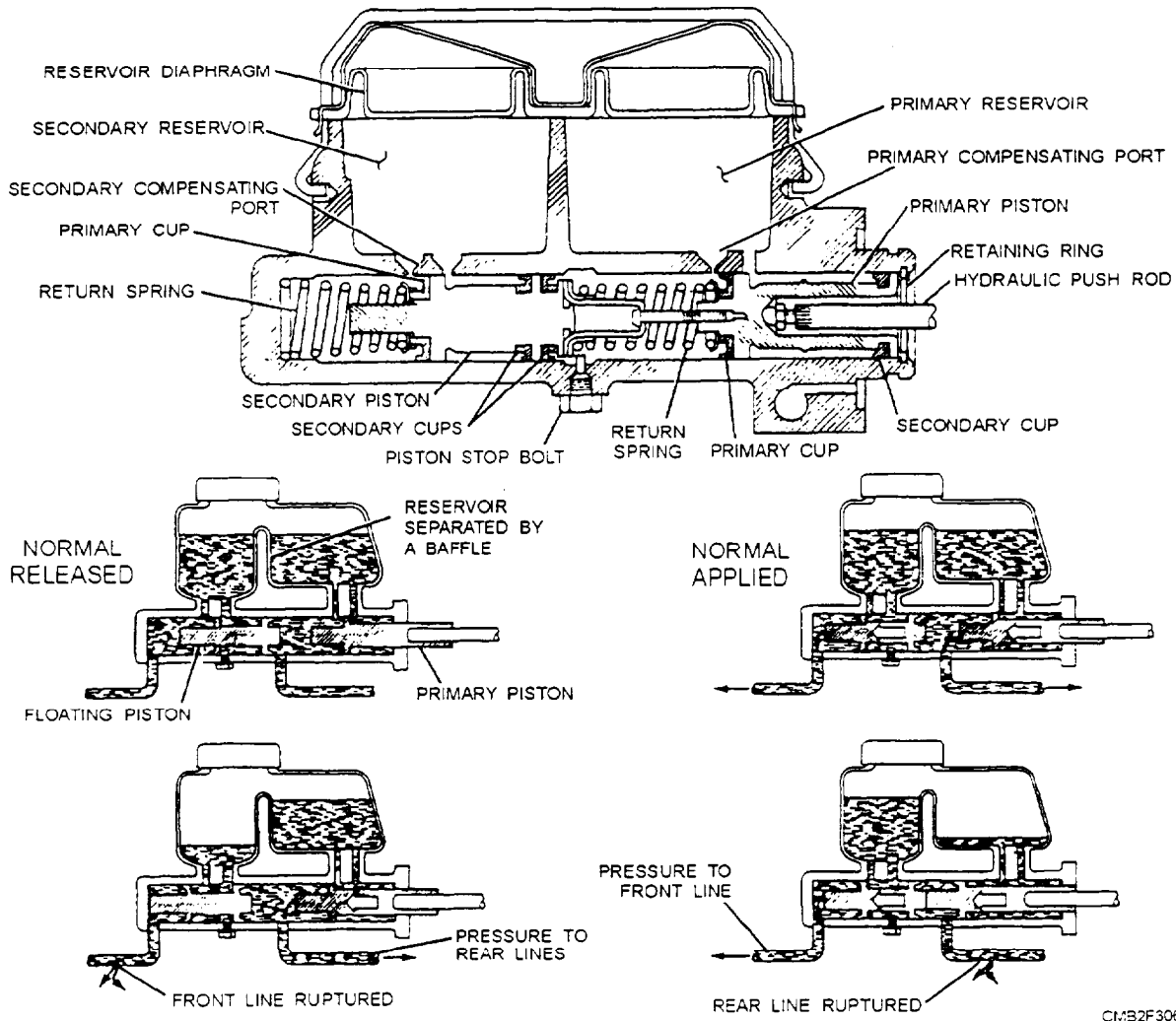

Figure 7-5.—Dual master cylinder.



pistons and two fluid reservoirs. In the dual master cylinder, the rear piston assembly is termed the *primary piston* and the front piston is termed the *secondary piston*.

In some dual master cylinders, the individual systems are designed where one master cylinder piston operates the front brake assemblies and the other operates the rear brake assemblies. This is known as a longitudinally split system (fig. 7-6). A system that has each master cylinder piston operating the brake assembly on opposite corners of the vehicle is known as a diagonally split system (fig. 7-6). In either system, if there is a leak, the other master cylinder system can still provide braking action on two wheels.

When the systems are intact (no leaks), the pistons produce and supply pressure to all four of the wheel cylinders. However, if there is a pressure loss in the primary circuit of the brake system (rear section of the master cylinder), the primary piston slides forward and pushes on the secondary piston. As shown in figure 7-5, this action forces the secondary piston forward mechanically, building pressure in two of the wheel cylinder assemblies. Should the secondary circuit fail, braking for the other two wheels would still be

available. The secondary piston slides completely forward in the cylinder, as shown in figure 7-5. Then the primary piston provides hydraulic pressure to the other two brake assemblies. It is very unlikely that both systems will fail at the same time.

When performing maintenance on a dual master cylinder, you may notice that the front reservoir is larger than the rear. This is a longitudinally split system. The larger reservoir is for disc brakes. The larger reservoir is necessary because as the disc pads wear, they move outward creating a larger cavity in the caliper cylinder and fluid moves from the master cylinder to fill the additional area. To allow this action to occur, the front reservoir of a longitudinally split system has no residual check valve. However, with a diagonally split system both reservoirs are the same size and the residual check valve for the rear brakes are located in the tees that split the system front to rear.

### Wheel Cylinder

A wheel cylinder (fig. 7-7) changes hydraulic pressure into mechanical force that pushes the brake shoes against the drums. Other than the standard wheel cylinder, there are two other types that you may come in contact with—the stepped wheel cylinder and the single-piston wheel cylinder.

- The stepped wheel cylinder (fig. 7-7) is used to compensate for a faster rate of wear on the front shoe than on the rear shoe because of the self-energizing action of the brakes. This condition requires a stepped wheel cylinder with two bore sizes.

- The single-piston wheel cylinder (fig. 7-7) is used when it is desired that both brake shoes be independently self-energizing, especially on the front wheels. With this design it is necessary to have two wheel cylinders, one for each shoe. Each cylinder has a single piston and is mounted on the opposite side of the brake backing plate from the other cylinder. Such an arrangement is shown in figure 7-8.

### NOTE

For further information on wheel cylinders, refer to "Drum Brake Assemblies" in this chapter.

### Brake Lines and Hoses

Brake lines and hoses transmit fluid under pressure from the master cylinder to the wheel cylinders. The brake lines are made of double-wall steel tubing with double-lap flares on their ends. Rubber brake hoses are

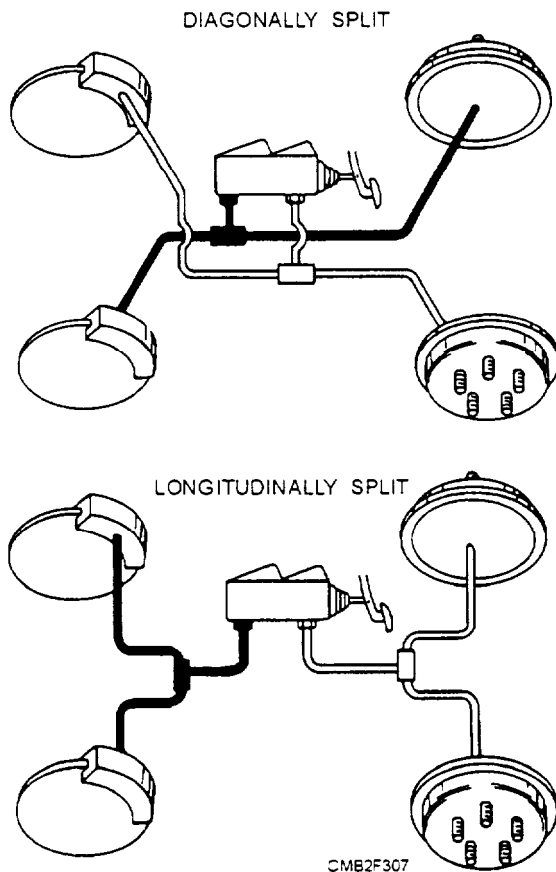

Figure 7-6.—Dual master cylinder braking systems.

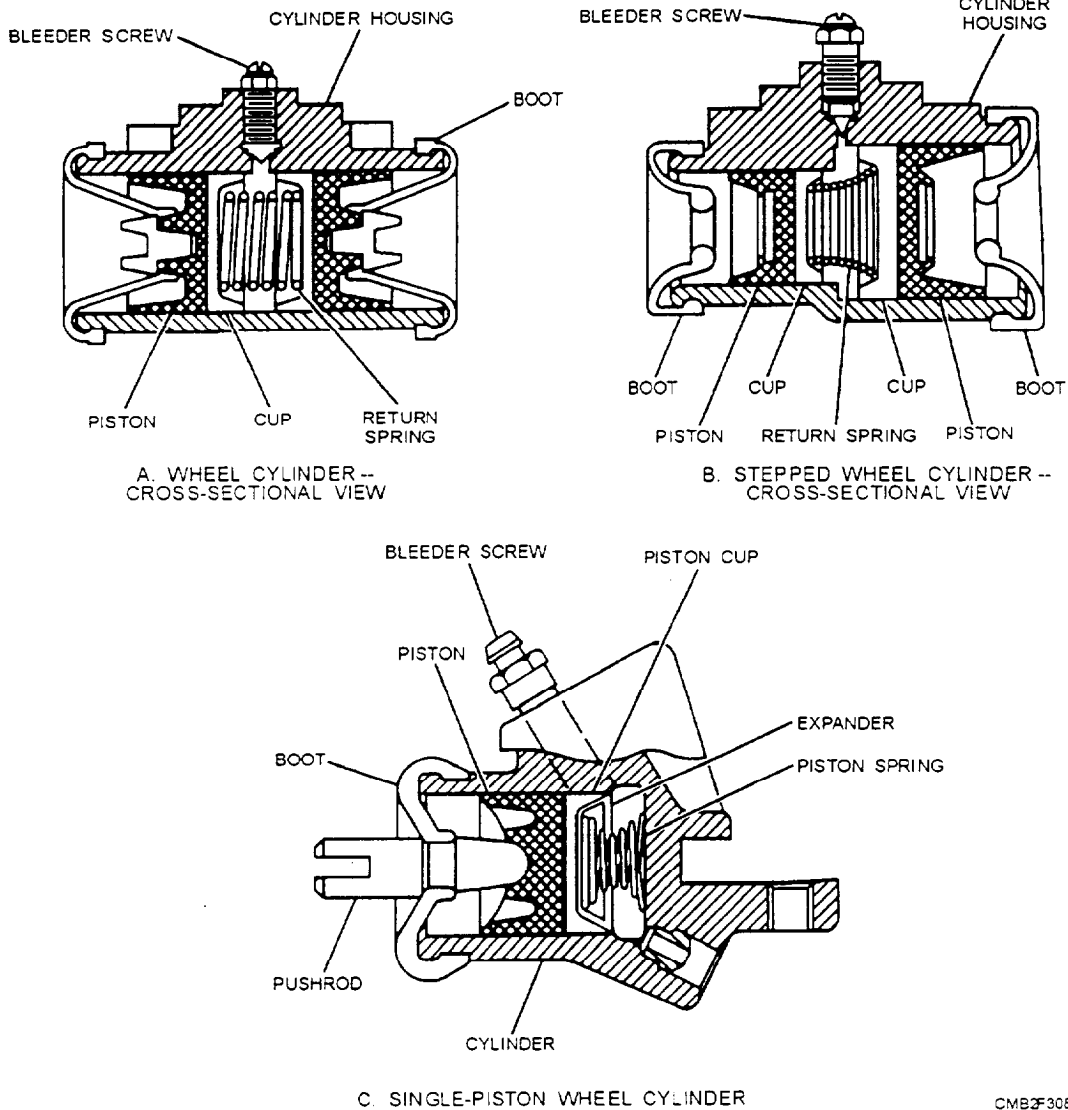

Figure 7-7.—Wheel cylinder configurations.

CMB2F308

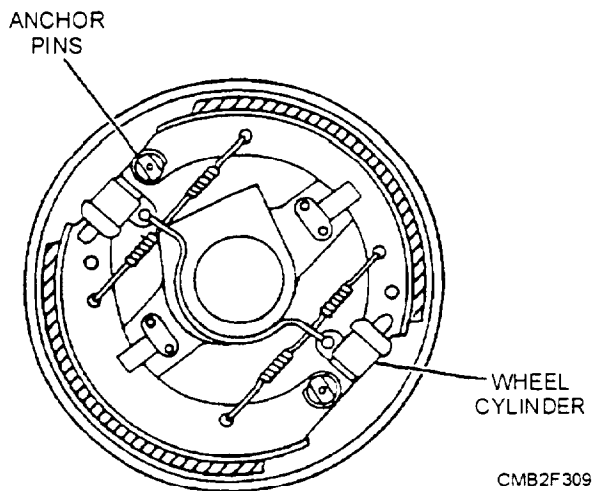

Figure 7-8.—Double-anchor, double-wheel cylinder configuration.

used where a flexing action is required. For example, a brake hose is used between the frame and the front-wheel cylinders or disc brake calipers. This design allows the wheels to move up and down, as well as side to side without damaging the brake line. Figure 7-9 shows the details of how brake lines and brake hoses fit together.

A junction block is used where a single brake line must feed two wheel cylinders or calipers. It is a simply a hollow fitting with one inlet and two or more outlets.

Mounting brackets and clips are used to secure brake lines and hoses to the unibody or frame of the vehicle. The mounting brackets help hold the assemblies secure and reduce the vibration which causes metal fatigue, thereby preventing line breakage.

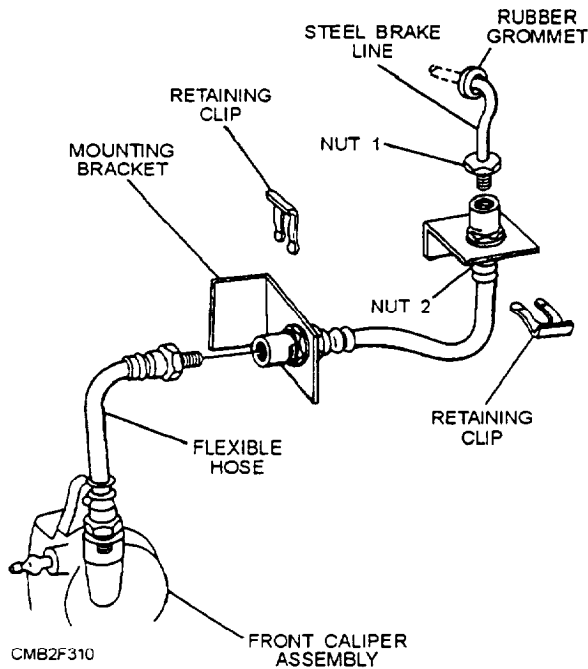

Figure 7-9.—Brake lines and hoses.

Steel lines seldom need replacing except in areas where they rust from exposure to salt air or constant high humidity. Flexible hoses should be inspected at regular maintenance periods for any signs of cracking or abrasion. Should the outer protective covering be cracked or badly abraded, it should be replaced.

### Brake Fluid

Brake fluid is a specially blended hydraulic fluid that transfers pressure to the wheel cylinders or calipers. Brake fluid is one of the most important components of a brake system because it ties all of the other components into a functioning unit.

Vehicle manufacturers recommend brake fluid that meets or exceeds SAE (Society of Automotive Engineers) and DOT (Department of Transportation) specifications.

Brake fluid must have the following characteristics:

- Low freezing point (not freeze during cold weather)
- Water tolerance (absorb moisture that collects in the system)
- Lubricate (reduce wear of pistons and cups)
- Noncorrosive (not attack metal or rubber brake system components)

- Maintain correct viscosity (free flowing at all temperatures)
- High boiling point (remains liquid at the highest system operating temperature)

Standard brake fluid (DOT 3) is composed chiefly of equal parts of alcohol and castor oil. This combination of fluids works well under normal conditions but it easily boils and becomes a vapor under heavy-duty applications. Standard fluid also tends to separate when exposed to low temperatures. The increasing requirements of brake fluid led to the development of silicone brake fluid.

After many years of research and development, a brake fluid that was acceptable under extreme operating conditions was developed. This fluid achieved low water pickup and good corrosion protection. The fluid also provides good lubrication qualities and rubber compatibility. Silicone brake fluid has been used in most military vehicles since the end of 1982.

## DRUM BRAKES

There are many types of brake system designs in use on modern vehicles. Regardless of the design, all systems require the use of rotating and nonrotating units. Each of these units houses one of the braking surfaces, which, when forced together, produce the friction for braking action. The rotating unit on many motor vehicle wheel brakes consists of a drum that is secured to and driven by the wheel. The nonrotating unit consists of the brake shoes and linkage required to applying the shoes to the drum.

### Drum Brake Assemblies

Drum brakes have a large drum that surrounds the brake shoes and hydraulic wheel cylinder. Drum brake assemblies consist of a backing plate, wheel cylinder, brake shoes and linings, retracting springs, hold-down springs, brake drum, and adjusting mechanism.

**BACKING PLATE.**—The backing plate holds the brake shoes, springs (retracting and hold-down), wheel cylinder, and other associated parts inside the brake drum. It also assists in keeping road dirt and water out of the brakes. The backing plate bolts to the axle housing or spindle.

**WHEEL CYLINDER.**—The wheel cylinder assembly uses master cylinder pressure to force the brake shoes out against the brake drum. It is normally bolted to the top of the backing plate. The wheel

cylinder consists of a cylinder or housing, expander spring, rubber cups, pistons, dust boots, and bleeder screw (fig. 7-10).

- The wheel cylinder housing encloses all the other parts of the assembly. It has a precision cylinder in it for the pistons, cups, and spring.
- The expander spring assists in holding the rubber cups against the pistons when the assembly is NOT pressurized. Sometimes the end of the springs has metal expanders (cup expanders) that help to press the outer edges of the cups against the wall of the wheel cylinder.
- The wheel cylinder cups are special rubber seals that keeps fluid from leaking past the pistons. They fit in the cylinder and against the pistons.
- The wheel cylinder pistons transfer force out of the wheel cylinder. These metal or plastic plungers act on pushrods that are connected to or directly on the brake shoes.
- The dust boots keep road dirt and water from entering the cylinder. They snap into grooves that are cast on the outside of the housing.
- The bleeder screw provides a means of removing air from the brake system. It threads into a hole in the back of the wheel cylinder. When the screw is loosened, hydraulic pressure is used to force air and fluid out of the system.

**BRAKE SHOES.**—Brake shoes are used to support, strengthen, and move the brake lining. Because the brake lining material is soft and brittle, it is necessary to add a supportive foundation to the lining so it will not collapse and break during use. The brake shoes also serve to attach the brake lining to a stationary unit, usually the backing plate, so braking action can be accomplished.

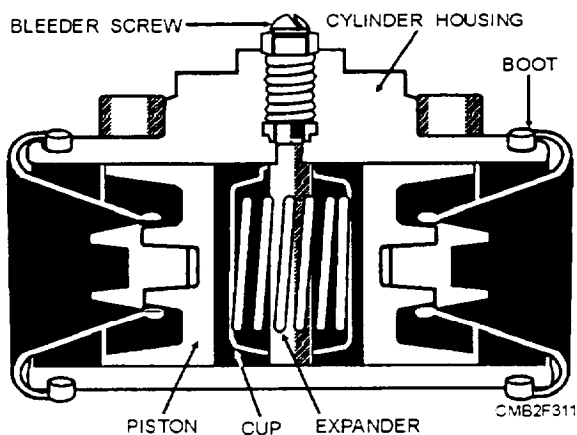

Figure 7-10.—Cross section of a wheel cylinder.

Brake shoes are made of malleable iron, cast steel, drop forged steel, pressed steel, or cast aluminum. Pressed steel is the most common because it is cheaper to produce in large quantities. Steel shoes expand at about the same rate as the drum when heat is generated by braking application, thereby maintaining the correct clearance between the brake drum and brake shoe under most conditions.

Automotive brake shoes consist of a primary and secondary shoe. The primary brake shoe is the front shoe and normally has a slightly shorter lining than the secondary shoe. The secondary shoe is the rear shoe and has the largest lining surface area.

Variation in brake design and operating conditions makes it necessary to have different types of brake linings. Brake linings come in woven and molded form (fig. 7-11).

The molded form is currently used on modern vehicles. Molded brake lining is made of dense, compact, asbestos fibers, sometimes impregnated with fine copper wire, and cut into sizes to match the brake shoe. Depending on how much metal fiber is used in their construction determines how they are classified, either as nonmetallic, semimetallic, and metallic linings.

- Nonmetallic linings contain very few metal fibers. This type of lining is used on many vehicles because of its quiet operation and good heat transfer qualities. Because of the lack of metal particles, the nonmetallic linings wear well with brake drums and do not tend to wear the drum excessively.

- Semimetallic linings have some metal particles in their composition. They also have good wearing properties and are quiet during application.

- Metallic linings have a high degree of metal fiber in their construction and are generally characterized by small pads bonded or welded to the brake shoe. The pads may have a small space between them to aid in cooling. The metallic linings operate at high temperatures and may require the use of special high-temperature brake parts. Metallic brake linings are generally used for heavy-duty brake application where large loads must be stopped or brakes are applied often.

Brake lining is riveted or bonded to the face of the brake shoe. Semitubular brass rivets are used to attach the lining to the shoe. Brass rivets are chosen over other types because brass does not score the brake drums excessively if the lining should be neglected and worn past the point of replacement.

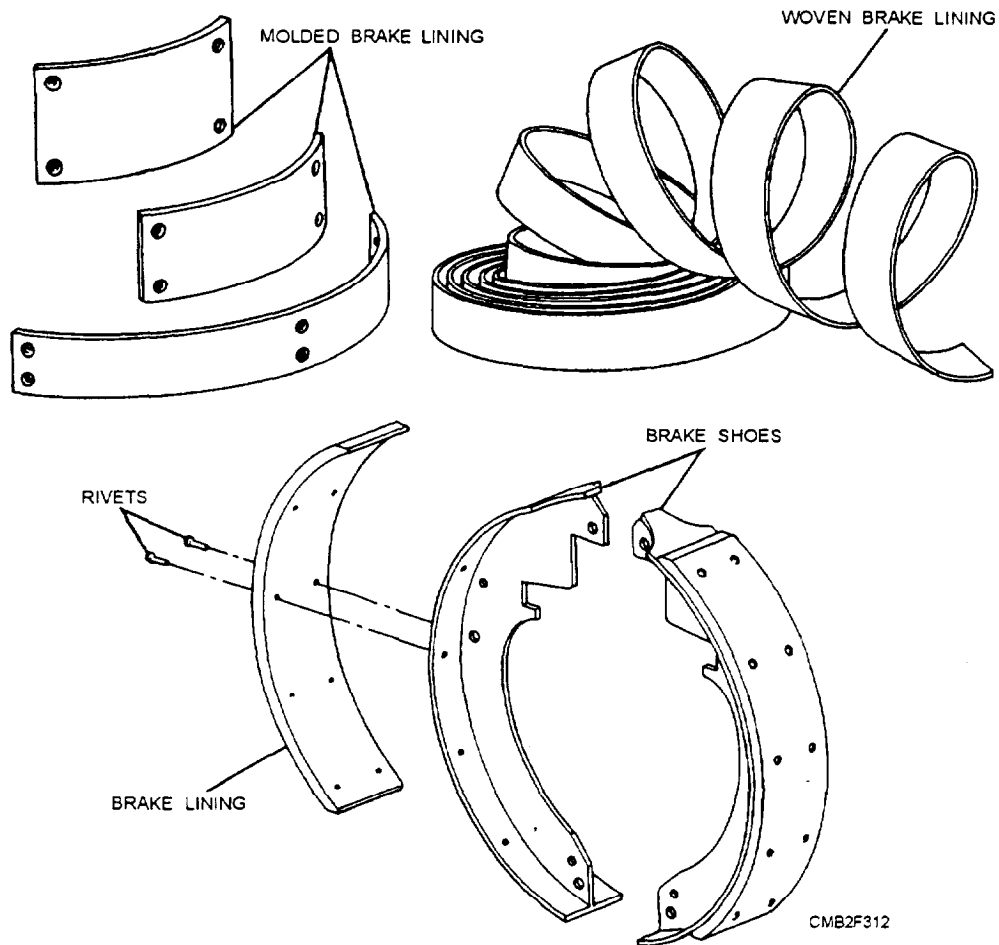

Figure 7-11.—Brake shoes and brake lining.

The lining may also be bonded directly to the brake shoe. In this process, a special bonding agent (glue) is used to adhere the lining to the brake shoe. After application, the shoe is baked at a predetermined temperature to ensure proper setting of the bonding agent.

**BRAKE SPRINGS.**—The brake springs within the brake drum assembly are the retracting springs and the hold-down springs. The retracting springs pull the brake shoes away from the brake drum when the brake pedal is released. The springs apply pressure to the brake shoes which push the wheel cylinder pistons inward. The retracting springs fit in holes in the brake shoes and around the anchor pin at the top of the backing plate.

Hold-down springs hold the brake shoes against the backing plate when the brakes are in a released position. A hold-down pin fits through the back of the backing plate, the spring placed over the pin, and a metal cup locks onto the pins to secure the hold-down springs to the shoes. Other springs are used on the adjusting mechanism. Brake springs are high quality,

capable of withstanding the high temperatures encountered inside the brake drum.

**BRAKE DRUMS.**—The brake drum is attached to the wheel and provides the rotating surface for the brake linings to rub against to achieve braking action. The brake drum is grooved to mate with a lip on the backing plate that provides the rotating seal to keep water and dirt from entering the brake assembly.

Brake drums may be made of pressed steel, cast iron, a combination of the two metals, or aluminum. Cast-iron drums dissipate the heat generated by friction faster than steel drums and have a higher coefficient of friction with any particular brake lining. However, cast-iron drums of sufficient strength are heavier than steel drums. To provide lightweight and sufficient strength, use CENTRIFUSE brake drums (fig. 7-12). These drums are made of steel with a cast-iron liner for the braking surface. A solid cast-iron drum of the same total thickness as the centrifuse drum would be too weak, while one of sufficient strength would be too heavy for the average vehicle.

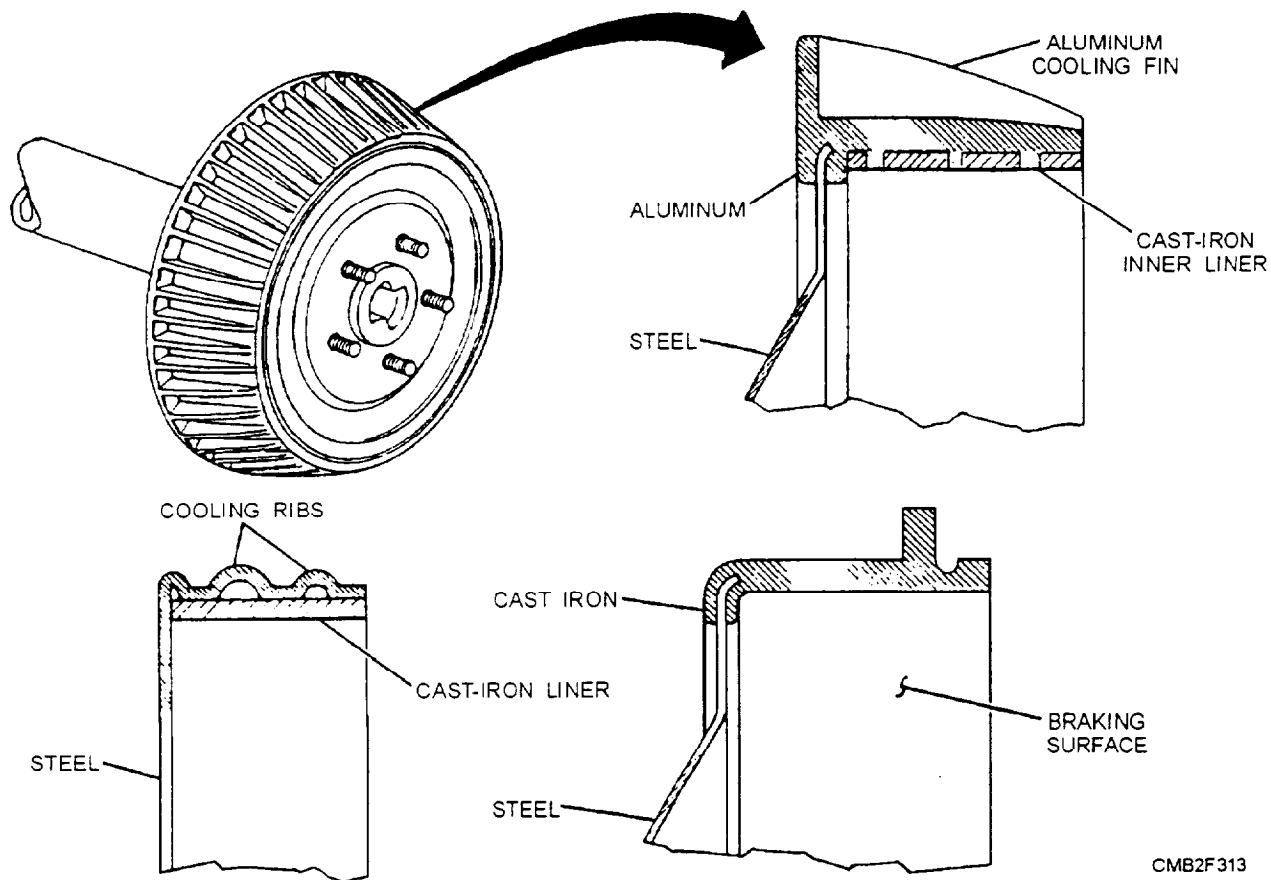

Figure 7-12.—Brake drum construction.

Aluminum brake drums are constructed similar to the centrifuse drums. They consist of an aluminum casting with a cast-iron liner for a braking surface. This design allows heat to be transferred to the surrounding atmosphere more readily and also reduces weight.

Cooling fins or ribs are added to most brake drums. The fins or ribs increase the surface area of the outside portion of the brake drum, allowing the heat to be transferred to the atmosphere more readily, which keeps the drum cooler and helps minimize brake fade.

For good braking action, the brake drum should be perfectly round and have a uniform surface. Brake drums become out-of-round from pressure exerted by brake shoes and from heat developed by application of the brakes. The brake drum surface becomes scored when it is worn by braking action. When the braking surface is scored or the brake drum is out-of-round, it may be necessary to machine the brake drum until it is smooth and true again. Care must be taken not to exceed the maximum allowable diameter according to the manufacturer's specification. Each drum is stamped with the maximum diameter information and.

if exceeded, it should be discarded and replaced with a new one.

**BRAKE SHOE ADJUSTERS.**—Brake shoe adjusters maintain correct drum-to-lining clearance, as the brake linings wear. Automatic brake shoe adjusters normally function when the brakes are applied with the vehicle moving in reverse. If there is too much lining clearance, the brake shoes move outward and rotate with the drum enough to operate the adjusting lever. This lengthens the adjusting mechanism, and the linings are moved closer to the brake drum, thereby maintaining the correct lining-to-drum clearance.

Many vehicles use a star wheel (screw) type brake shoe adjusting mechanism. This type consists of a star wheel (adjusting screw assembly), adjuster lever, adjuster spring, and an adjusting mechanism. The adjustment system may be grouped as follows (fig. 7-13):

- Cable type—The cable type self-adjusting system (fig. 7-13) uses a braided steel cable and the expanding action of both brake shoes to accomplish the self-adjusting action in forward and reverse directions. A one-piece cable is attached to the adjusting lever and passes through a cable guide on the primary shoe. The

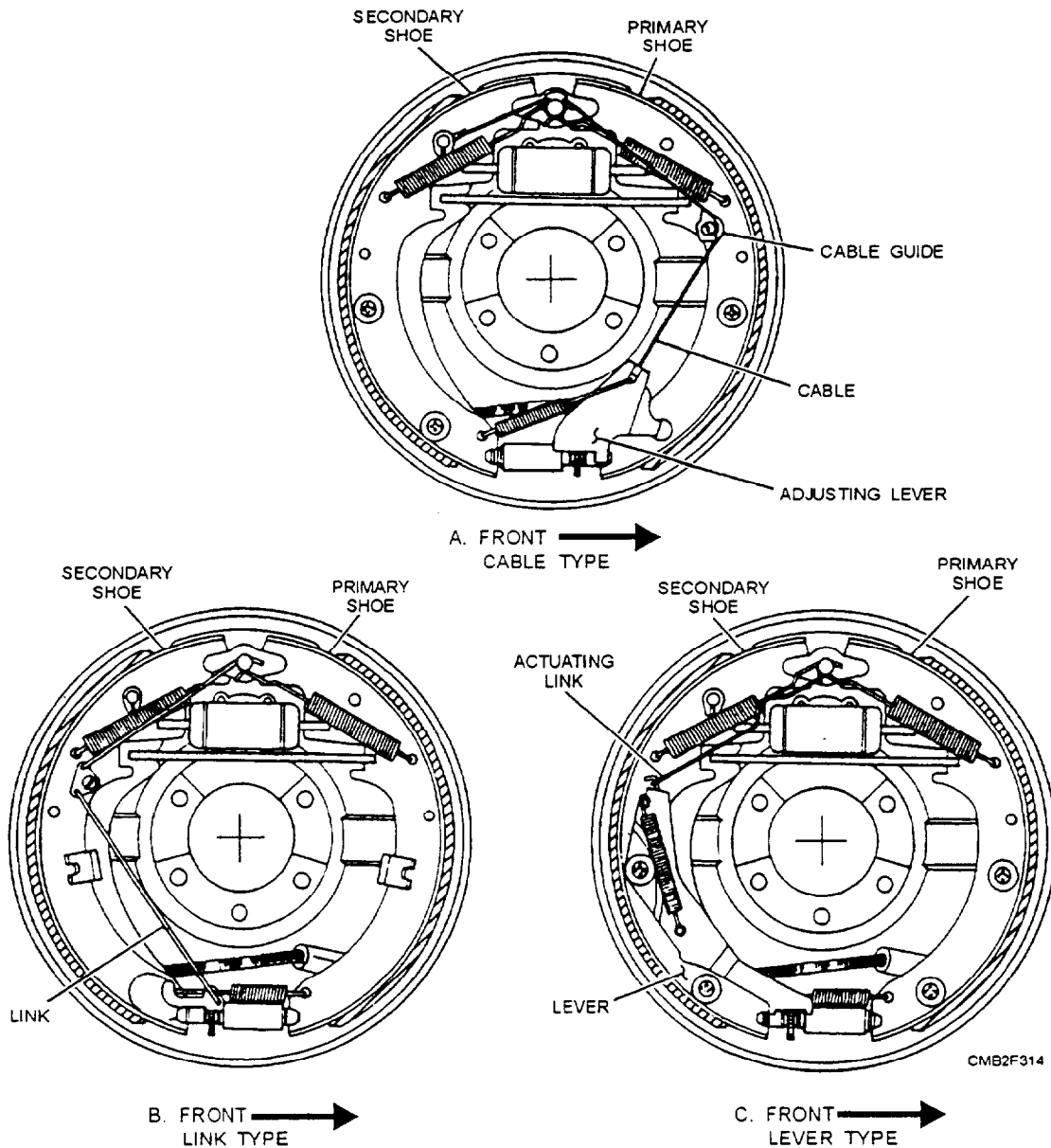

Figure 7-13.—Self-adjusting mechanisms.

cable then is passed up and over the anchor and attached to the secondary shoe. Operation is as follows:

1. Brakes are applied and the shoes expand and contact the drum.
2. The primary shoe self-energizes, and, through servo action, applies the secondary shoe.
3. The heel of the secondary shoe is lodged against the anchor pin.
4. The movement of the primary shoe tightens the cable by shifting the cable guide outward and in the direction of rotation.
5. The cable then moves the adjusting lever upward. If enough shoe-to-drum clearance is available,

the adjusting lever will engage the next tooth on the star wheel. The brake shoes retract and the cable slackens, as the brakes are released. The return spring then helps force the adjusting lever downward, rotating the star wheel, which expands the brake shoes. In the reverse direction, the toe of the primary shoe is forced against the anchor, and the secondary shoe moves around to tighten the adjusting cable. The adjusting process is then completed.

- Link type—The link type self-adjusting system (fig. 7-13) uses solid linkage rods to connect the adjusting lever to the stationary anchor point. The two linkage rods, connected together by a bell crank that pivots on the secondary brake shoe, operate the adjuster. One rod attaches to the anchor point and the bell crank,

while the other rod connects the bell crank and the adjusting lever. In this configuration, the self-adjuster works only in reverse direction. As the vehicle is backing up and the brakes are applied, the adjusting process is as follows:

1. The secondary, shoe moves away from the anchor because of the self-energizing action.
2. The pivot point of the bell crank is moved in the direction of rotation.
3. The lever moves up on the star wheel through the connection of the linkage. If enough clearance is available between the brake shoes and the drum, the lever will engage another tooth on the star wheel. As the brakes are released, the shoes retract and the return spring helps force the adjusting lever down, rotating the star wheel and expanding the adjusting screw to remove excess shoe-to-drum clearance.

- **Lever type**—The lever type self-adjusting system (fig. 7-13) is similar to the link type, in that it operates in reverse direction only. While the link type system uses linkage rods to perform the adjusting process, the lever type uses a stamped metal lever to engage the star wheel and actuating link to connect to the anchor pin. The adjusting process is the same as the link type system.

### **Brake Shoe Energization**

The primary function of the brake drum assembly is to force the brake shoes against the rotating drum to provide the braking action. When the brake shoes are forced against the rotating drum, they are pulled away from their pivot point by friction. This movement, called self-energizing action (fig. 7-14), draws the shoes tighter against the drum.

As the brake actuating mechanism forces the brake shoes outward, the top of the brake shoe tends to stick or wedge to the rotating brake drum and rotates with it. This effect on brake shoes greatly reduces the amount of effort required to stop or slow down the vehicle.

With most drum brake designs, shoe energization is supplemented by servo action. When two brake shoes are linked together, as shown in figure 7-14, the application of the brakes will produce a self-energizing effect and also a servo effect. Servo action is a result of the primary (front) shoe attempting to rotate with the brake drum. Because of the fact that

both shoes are linked together, the rotating force of the primary shoe applies the secondary, (rear) shoe.

In the forward position, the anchor point for both brake shoes is at the heel of the secondary, shoe. As the vehicle changes direction from forward to reverse, the toe of the primary shoe becomes the anchor point, and the direction of self-energization and servo action changes (fig. 7-14). The most popular brake drum configurations (fig. 7-15) are as follows:

- **Single anchor, self-energizing servo action** (fig. 7-15)—In this configuration both brake shoes are self-energizing in both forward and reverse directions. The brake shoes are self-centering and provide servo action during brake application. This system is provided with one anchor pin, which is rigidly mounted to the backing plate and is nonadjustable. Both forward and reverse torque is transmitted to the backing plate through the anchor pin. One wheel cylinder with dual pistons is used in this system.

- **Single anchor, self-centering** (fig. 7-15)—In this configuration only the primary brake shoe is self-energizing in the forward direction; therefore, it provides the majority of the brake force. This system is self-centering in that the lower brake shoe anchor does not fix the position of the brake shoes in relation to the drum. The shoes are allowed to move up and down as needed. Some systems provide eccentric cams for front and rear brake shoe adjustments. One wheel cylinder is provided in this system.

- **Double anchor, single cylinder** (fig. 7-15)—In this arrangement, each brake shoe is anchored at the bottom by rotating eccentric-shaped anchor pins. Only the primary shoe is self-energizing, and the system does not develop servo action. Spring clips are used in the middle of the shoe to hold the shoes against the backing plate. Brake shoes are adjusted manually by rotating the anchor pins. One wheel cylinder is provided in this arrangement.

- **Double anchor, double cylinder** (fig. 7-15)—In this system the brake shoes are provided with an anchor at each heel. The anchors are eccentric-shaped to allow for adjustment and centering. Each shoe has a single piston wheel cylinder mounted at the toe of the brake shoe. Which allows both shoes to be self-energizing in the forward direction only. Eccentrics mounted in the middle of the shoe also allow for brake adjustment.

### **Disadvantages of Drum Brakes**

The drum brake assembly, although well suited for wheeled vehicles, has some disadvantages. One



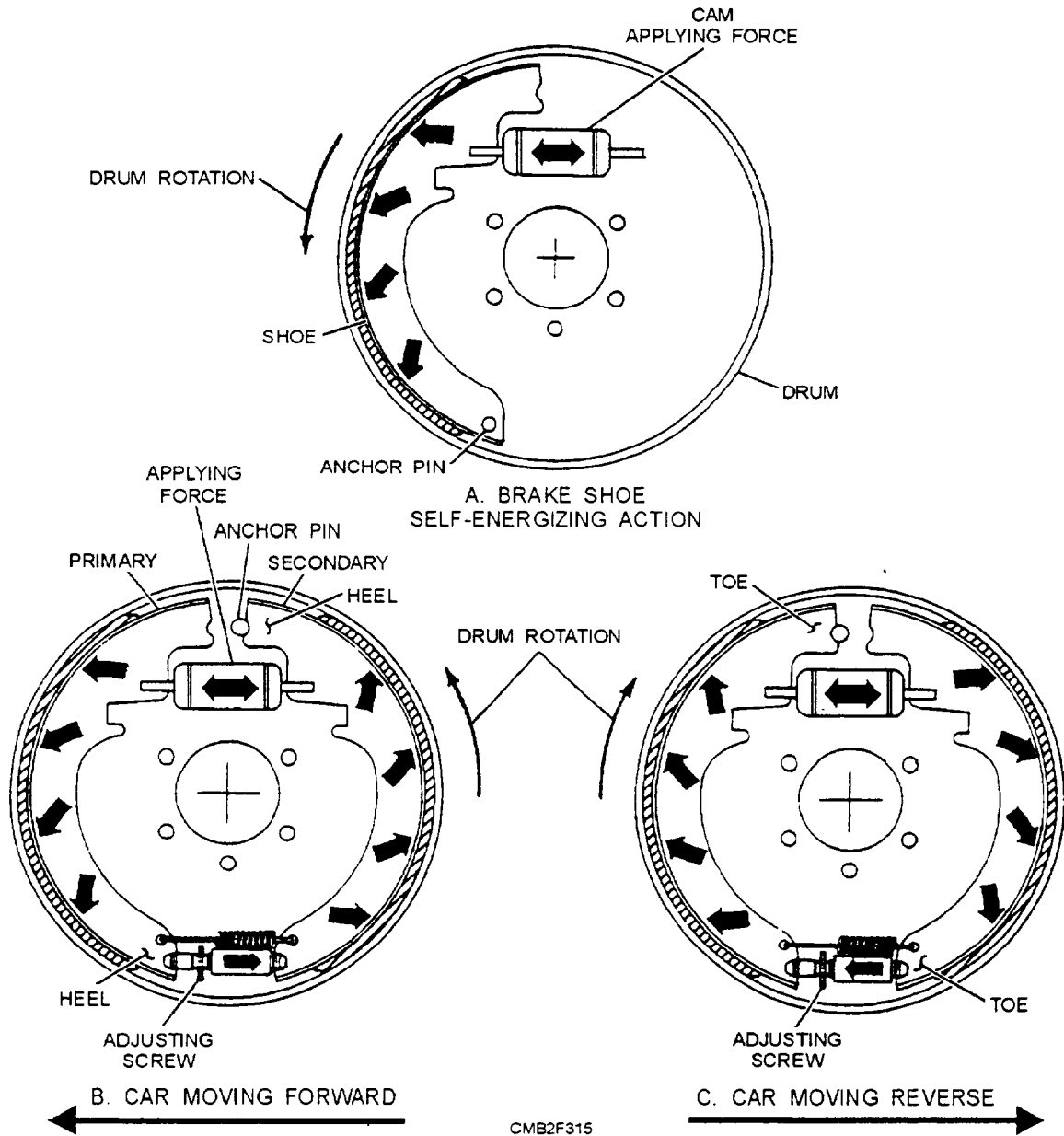

Figure 7-14.—Self-energizing and servo action.

problem that occurs during heavy braking is brake fade. During panic stops or repeated harsh stops, the brake linings and drum develop large amounts of heat that reduces the amount of friction between the brake shoe and drum. This reduction in friction greatly decreases the stopping ability of the vehicle, and, in most cases, additional pressure directed on the brake pedal would not increase the stopping performance of the vehicle.

The enclosed design of the brake drum assembly does not allow for cooling air to enter the assembly and therefore heat developed during braking must be dissipated through the brake drum and backing plate. As the brakes heat up due to repeated application,

cooling air flowing past the drums and backing plates is limited. This condition causes the radius of the drum to increase more than the radius of the brake shoe. As a result, a change in pressure distribution between the linings and the drum occurs, which reduces the braking ability of a vehicle by up to 20 percent.

The enclosed design also does not allow for water to be expelled rapidly should the brake cavity become wet due to adverse weather conditions. The water reduces the frictional properties of the brake system and must be removed to restore braking ability. This is a very dangerous situation and drastically reduces the stopping ability of the vehicle until the system is dry.

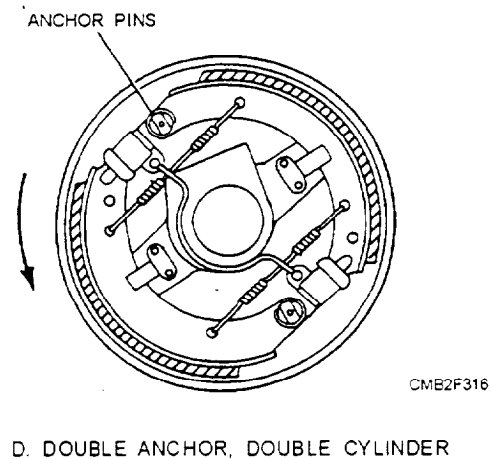
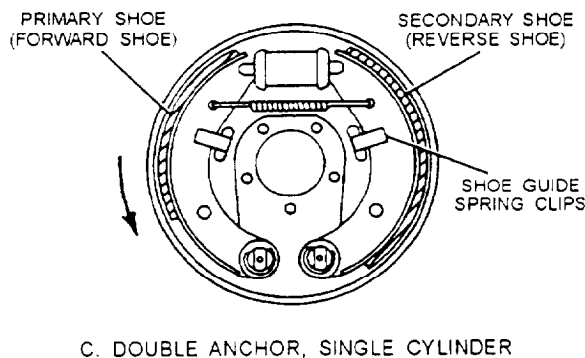
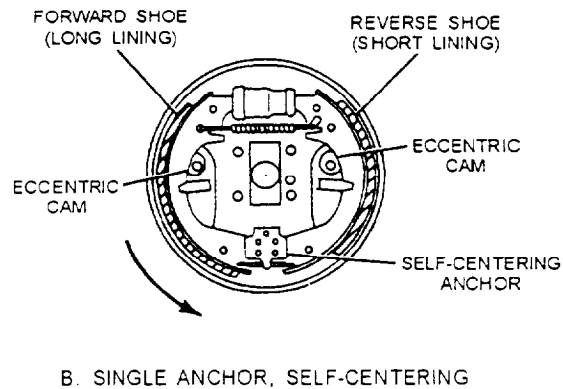
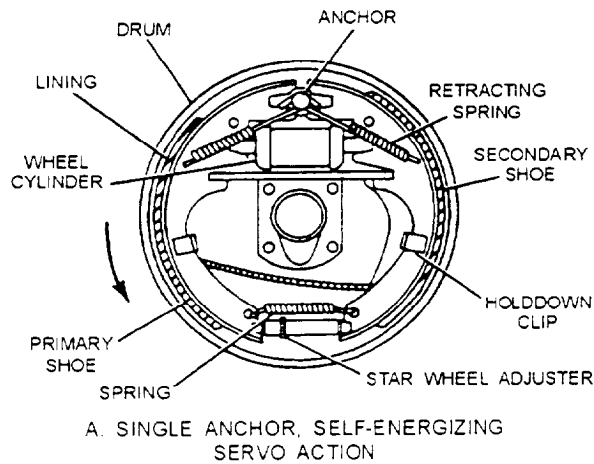

Figure 7-15.—Brake drum configurations.

The use of many clips and springs makes overhaul of the brake drum assembly very time-consuming. Because of the enclosed drum, asbestos dust is collected in the brake cavity and certain parts of the brake drum.

### CAUTION

Asbestos can cause cancer. Grinding brake lining and cleaning of the brake assembly can cause small particles of asbestos to become airborne. Always wear personal protection equipment. Dispose of waste material and cleaning rags as hazardous waste. For more information, see OPNAVINST 4110.2, *Hazardous Material Control and Management*.

### DISC BRAKES

With the demands for increased safety in the operation of automotive vehicles, many are now equipped with disc brakes. The major advantage of the disc brake is a great reduction in brake fade and the

consequent marked reduction in the distance required to stop the vehicle.

Braking with disc brakes is accomplished by forcing friction pads against both sides of a rotating metal disc, or rotor. The rotor turns with the wheel of the vehicle and is straddled by the caliper assembly. When the brake pedal is depressed, hydraulic fluid forces the pistons and friction linings (pads) against the machined surfaces of the rotor. The pinching action of the pads quickly creates friction and heat to slow down or stop the vehicle.

Disc brakes do not have servo or self-energizing action. Therefore, the applying force on the brake pedal must be very great in order to obtain a brake force comparable to that obtained with the conventional drum brake. Consequently, disc brakes are provided with a power or booster unit and a conventional master cylinder.

In many installations, disc brakes are used only on the front wheels and drum brakes are continued on the rear. However, you may on occasion find disc brakes used on all four wheels.

## Disc Brake Assembly

Disc brakes are basically like the brakes on a ten-speed bicycle. The friction elements are shaped like pads and are squeezed inwards to clamp a rotating disc or wheel. A disc brake assembly consists of a caliper, brake pads, rotor, and related hardware (bolts, clips, and springs), as shown in figure 7-16.

**BRAKE CALIPER.**—The caliper is the nonrotating unit in the system and it may be mounted to the spindle or splash shield to provide support. The brake caliper assembly includes the caliper housing, the piston(s), the piston seal(s), the dust boot(s), the brake pads or shoes, and the bleeder screw.

The caliper is fitted with one or more pistons that are hydraulically actuated by the fluid pressure developed in the system. When the brake pedal is applied, brake fluid flows into the caliper cylinder. The piston is then forced outward by fluid pressure to apply the brake pads to the rotor.

The piston seal in the caliper cylinder prevents pressure leakage between the piston and cylinder. The piston seal also helps pull the piston back into the cylinder when the brakes are released. The elastic action of the seal acts as a spring to retract the piston and maintain a clearance of approximately 0.005 inch when the brakes are released.

The piston boot keeps road dirt and water off the caliper piston and wall of the cylinder. The boot and seal fit into grooves cut in the caliper cylinder and piston.

A bleeder screw allows air to be removed from the hydraulic system. It is threaded into the top or side of

the caliper housing. When loosened, system pressure is used to force fluid and air out of the bleeder screw.

**DISC BRAKE PADS.**—Disc brake pads consist of steel shoes to which the lining is riveted or bonded. Brake pad linings are made of either asbestos (asbestos fiber filled) or semimetallic (metal particle filled) friction material. Many new vehicles, especially those with front-wheel drive, use semimetallic linings. Semimetallic linings withstand higher operating temperatures without losing their frictional properties.

Antirattle clips are frequently used to keep the brake pads from vibrating and rattling. The clip snaps onto the brake pad to produce a force fit in the caliper. In some cases, an antirattle spring is used instead of a clip.

A pad wear indicator (a metal tab) informs the operator of worn brake pad linings. The wear indicator produces an audible high-pitch squeak or squeal, as it scrapes against the brake disc. This harsh noise is a result of the linings wearing to a point, allowing the indicator to rub against the brake disc, as the wheel turns.

**BRAKE DISC.**—Also called brake rotor, the brake disc uses friction from the brake pads to slow or stop the vehicle. Made of cast iron, the rotor may be an integral part of the wheel hub. However, on many front-wheel drive vehicles, the disc and hub are separate units.

The brake disc may be a ventilated rib or solid type. The ventilated rib disc is hollow that allows cooling air to circulate inside the disc.

### Disc Brake Types

Disc brakes can be classified as floating, sliding, and fixed caliper types. Floating and sliding are the most common types. The fixed caliper may be found on older vehicles.

**FLOATING CALIPER.**—The floating caliper type disc brake (fig. 7-17) is designed to move laterally on its mount. This movement allows the caliper to maintain a centered position with respect to the rotor. This design also permits the braking force to be applied equally to both sides of the rotor. The floating caliper usually is a one-piece solid construction and uses a single piston to develop the braking force.

Operation of a floating caliper is as follows:

- Fluid under pressure enters the piston cavity and forces the piston outward. As this happens the brake pad contacts the rotor.

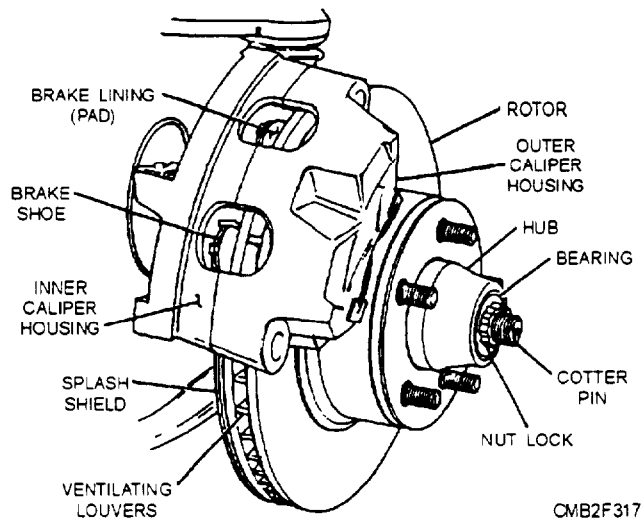

Figure 7-16.—Disc brake assembly.

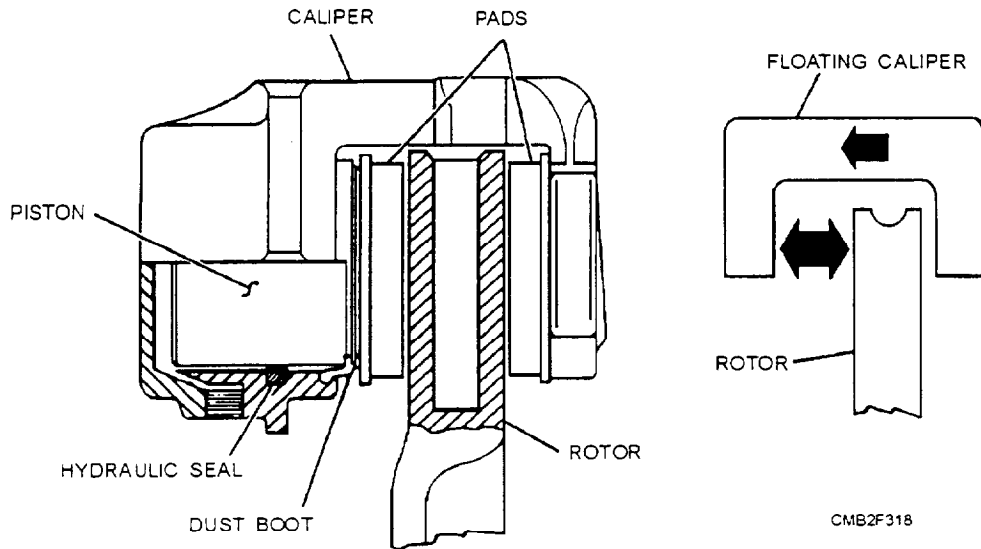

Figure 7-17.—Floating caliper.

- Additional pressure then forces the caliper assembly to move in the opposite direction of the piston, thereby forcing the brake pad on the opposite side to contact the rotor.
- As pressure is built up behind the piston, it forces the brake pads to tighten against the rotor. This action develops additional braking force.

**SLIDING CALIPER TYPE.**—The sliding caliper type disc brake (fig. 7-18) is mounted in a slot in the caliper adapter. It is a variation of the floating caliper, using a single piston and operating on the same principle, whereby the piston applies pressure to one brake pad and the movable caliper applies pressure to the other.

This design has two major sections—the sliding caliper and the caliper adapter (anchor plate). Each has two angular machined surfaces: this is where the sliding contacts come into play. The machined surfaces of the caliper housing slide on the mated

surfaces of the caliper adapter when the brakes are applied.

**FIXED CALIPER.**—The fixed caliper disc brake (fig. 7-19) is rigidly mounted to the spindle or splash shield. In this design, the caliper usually is made in two pieces and has two or more pistons in use.

The pistons accomplish the centering action of the fixed caliper, as they move in their bores. If the lining should wear unevenly on one side of the caliper, the piston would take up the excess clearance simply by moving further out of the bore.

As the brakes are applied, fluid pressure enters the caliper on one side and is routed to the other through an internal passage or by an external tube connected to the opposite half of the caliper. As pressure is increased, the pistons force the brake pads against the rotor evenly, therefore maintaining an equal amount of pressure on both sides of the rotor.

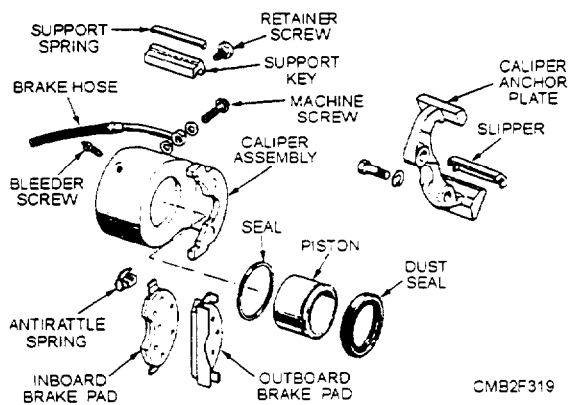

Figure 7-18.—Sliding caliper.

## BRAKE SWITCHES AND CONTROL VALVES

There are several types of switches and control valves used in hydraulic brake systems. Switches are normally safety devices, and there are two types used—the stoplight switch and the braking warning light switch. Control valves regulate pressure within the braking system, and there are three types—the metering valve, the proportioning valve, and the combination valve.

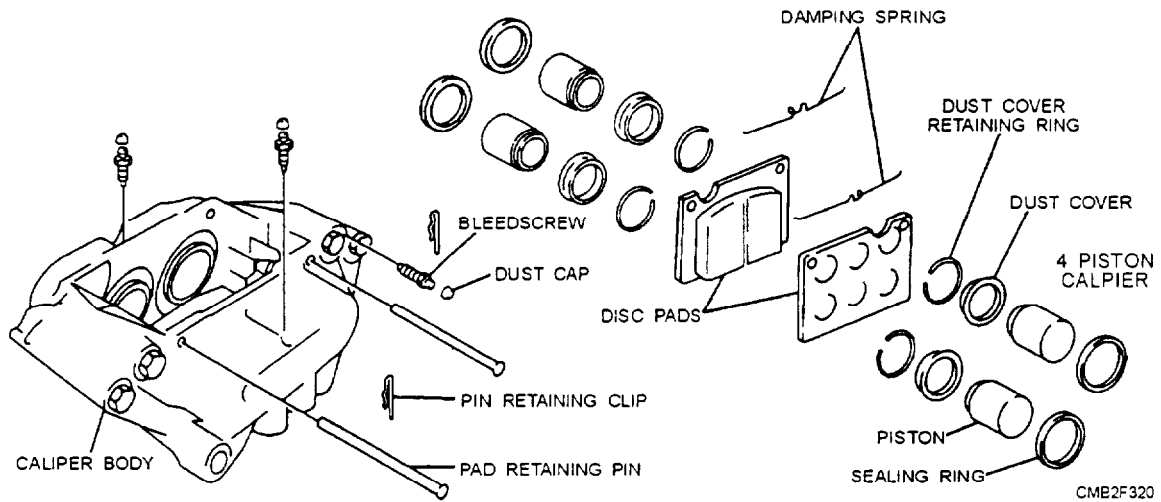

Figure 7-19.—Fixed multipiston caliper.

### Stoplight Switch

The stoplight switch is a spring-loaded electrical switch that operates the rear brake lights of the vehicle. Most modern vehicles use a mechanical switch on the brake pedal mechanism. The switch is normally open, and when the brake pedal is depressed, the switch closes and turns on the brake lights.

On some older vehicles you may find hydraulically operated stoplight switches. In this system, brake pressure acts on a switch diaphragm, which closes the switch to turn on the brake lights.

#### NOTE

Brake light circuits are covered in chapter 2 of this TRAMAN.

### Brake Warning Light Switch

The brake Learning light switch, also called the pressure differential valve, warns the operator of a pressure loss on one side of a dual brake system. If a leak develops in either the primary or secondary brake system, unequal pressure acts on each side of the warning light piston, moving the piston to one side thereby grounding the switch.

### Metering Valve

The metering valve is designed to equalize braking action at each wheel during light brake applications. A metering valve is used on vehicles with front disc brakes and rear drum brakes and is located in the line to the disc brakes. The metering valve functions by

preventing the disc brakes from applying until approximately 75 to 135 psi has built up in the system.

### Proportioning Valve

The proportioning valve also equalizes braking action with front disc brakes and rear drum brakes. It is located in the brake line to the rear brakes. The function of the proportioning valve is to limit pressure to the rear brakes when high pressure is required to apply the front disc. This prevents rear wheel lockup and skidding during heavy brake applications.

### Combination Valve

The combination valve (fig. 7-20) combines several valve functions into a single assembly. It functions as a—

- Metering valve—holds off front disc braking until the rear drum brakes make contact with the drums.
- Proportioning valve—improves front to rear brake balance at high deceleration by reducing rear brake pressure to delay rear wheel skid.
- Brake light warning switch (pressure differential valve)—lights a dash-warning lamp if either front or rear brake systems fail.

### ANTILOCK BRAKE SYSTEM (ABS)

The antilock brake system (ABS) is used because it provides CONTROL. Skidding causes a high percentage of vehicle accidents on the highway and the ABS (fig. 7-21), also known as a skid control brake system, uses wheel speed sensors, hydraulic valves, and the on-board computer to prevent or limit tire

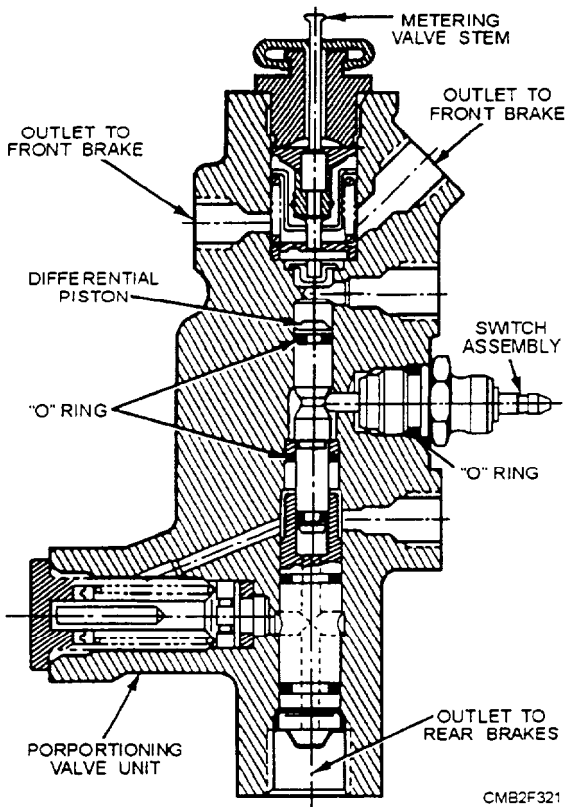

Figure 7-20.—Combination valve.

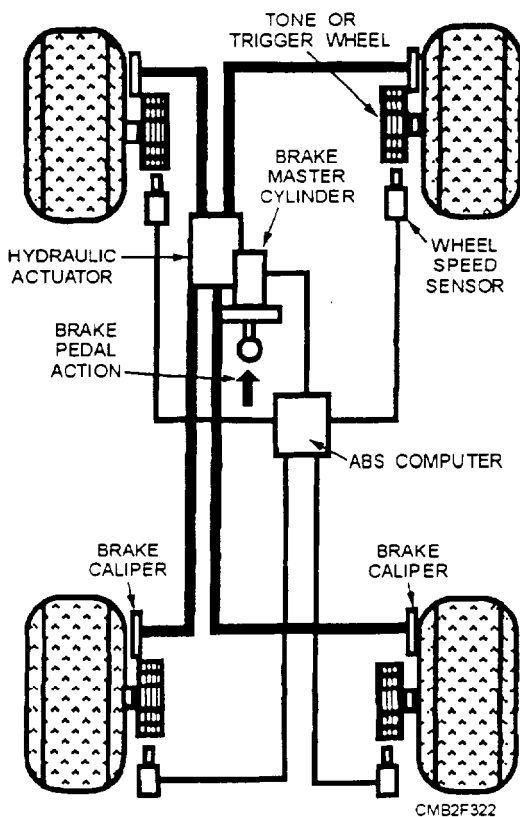

Figure 7-21.—Basic antilock brake system.

lockup. The basic parts of an antilock brake system are as follows:

- **ABS COMPUTER**—a microcomputer that functions as the "brain" of the ABS system. The computer receives wheel-end performance data from each wheel speed sensor. When the wheels try to lock, the computer delivers commands to operate the hydraulic actuator to control brake pressure. The computer also monitors brake pedal position, detects and prevents potential wheel lockup conditions while maintaining optimum braking performance, stores and displays diagnostic codes, and alerts the operator of a system malfunction by turning on the system lamp.
- **HYDRAULIC ACTUATOR**—an electric-hydraulic valve that modulates the amount of braking pressure (psi) going to a specific wheel circuit.
- **TRIGGER WHEELS**—a toothed ring that is mounted on each wheel spindle or hub.
- **WHEEL SPEED SENSORS**—a magnetic sensor that uses trigger wheel rotation to produce a weak alternating current.

The operation of an antilock brake system is as follows:

- A wheel speed sensor is mounted at each wheel to measure trigger wheel rotation in rpms. The sensor sends alternating or pulsing current signals to the ABS computer.
- If one or more wheels decelerate at a rate above an acceptable perimeter, the sensor signals reduce frequency and the ABS computer activates the hydraulic actuators. The actuator then cycles ON and OFF as much as 15 times per second to reduce braking pressure to the brake assembly for that wheel. This action prevents the vehicle from skidding.
- The ABS computer will continue to modulate brake pressure until the operator releases the brake pedal, the wheel speed sensor no longer detects a lockup condition, or the vehicle stops.

Tips on using antilock braking systems are as follows:

- Always "brake and steer" when using antilock brakes. Most operators were taught to pump the brakes and turn hard to the right or left to compensate for skidding. With antilock brakes, all an operator needs to do is "brake and steer." With four-wheel antilock brakes, push the brake pedal hard while steering normally and keep your foot firmly on the brake pedal until the vehicle comes to a complete stop. Operators

with rear-wheel antilock brakes should step firmly with care. and if they feel the wheel locking, they should release some pressure.

- Expect noise and vibration in the brake pedal when antitock brakes are in use. The mechanical noise or pulsation of antilock brakes when in use might catch an operator by surprise; however, these sensations tell you that the system is working.

- Remember that you can steer while braking with a four-wheel antilock brake system. Steering is not always instinctive in an emergency. But steer out of danger while braking with antilock brakes. And remember that while you have steering capability, your vehicle may not turn as quickly while braking on a slippery road, as it would on dry pavement.

- The rear-wheel antitock brakes typically found on light-duty trucks provide vehicle stability but do not give you the steering capability of four-wheel antilock brakes.

- Anti lock brakes can often stop more quickly than conventional brakes but they can't overcome the law of physics. Antilock brakes function well on wet-paved surfaces and icy or packed snow-covered roads. Stopping times will be longer on gravel or fresh snow, although operators won't experience the dangerous lockup of wheels usually associated with conventional brakes.

- Drive safely because antilock brakes are only as good as the operators using them. Antilock brakes cannot compensate for driving too fast, too aggressively or failing to maintain a safe distance between vehicles. They cannot guarantee recovery from a spin or skid before braking. Also avoid extreme steering maneuvers while antilock brakes are engaged.

- Your antilock braking system instrument panel light will go on for a few seconds after starting the ignition. The light goes on so the system can conduct the normal system test. If the light does not go on during ignition or if the light goes on during normal driving, this means that a problem has been detected and the antilock braking system has been shut off. Conventional braking will continue. Consult the manufacturer's service manual if this problem occurs.

Since exact antitock brake systems vary, consult the vehicle manufacturer's service and repair manuals for more details of system operation.

## **POWER BRAKES**

Power brakes systems are designed to reduce the effort required to depress the brake pedal when

stopping or holding a vehicle stationary. The booster is located between the brake pedal linkage and the master cylinder.

Most power brake systems use the difference between intake manifold vacuum and atmospheric pressure to develop the additional force required to apply the brakes. When the operator depresses the brake pedal, the power booster increases the amount of pressure applied to the piston within the master cylinder without the operator having to greatly increase brake pedal pressure.

When a vehicle is powered by a diesel engine, the absence of intake manifold vacuum requires the use of an auxiliary vacuum pump. This pump may be driven by the engine or by an electric motor.

### **Vacuum Boosters**

On many modern vehicles, vacuum boosters are used with the hydraulic brake system to provide easier brake application. In a hydraulic brake system there are limitations as to the size of the master cylinder and wheel cylinders that can be practically employed. Furthermore, the physical strength of the operator limits the amount of force that can be applied, unless the brakes are self-energizing. These factors restrict the brake shoe to brake drum pressure obtainable. Vacuum boosters increase braking force.

A vacuum booster consists of a round enclosed housing and a diaphragm. The power brake vacuum booster uses engine vacuum (or vacuum pump action on a diesel engine) to apply the hydraulic brake system. Vacuum boosters are classified into two types (fig.7-22)—atmospheric suspended and vacuum suspended. The descriptions of the two types are as follows:

- An atmospheric suspended brake booster (fig. 7-22) has normal air pressure on both sides of the diaphragm when the brake pedal is released. As the brakes are applied, a vacuum is formed in one side of the booster. Atmospheric pressure then pushes on and moves the diaphragm.

- An vacuum suspended brake booster (fig. 7-22) has vacuum on both sides of the diaphragm when the brake pedal is released. Pushing down on the brake pedal releases vacuum on one side of the booster. The difference in air pressure pushes the diaphragm for braking action.

Air has a weight of approximately 15 pounds per square inch at sea level. The weight of the air or atmospheric pressure is what is used to operate the vacuum booster.

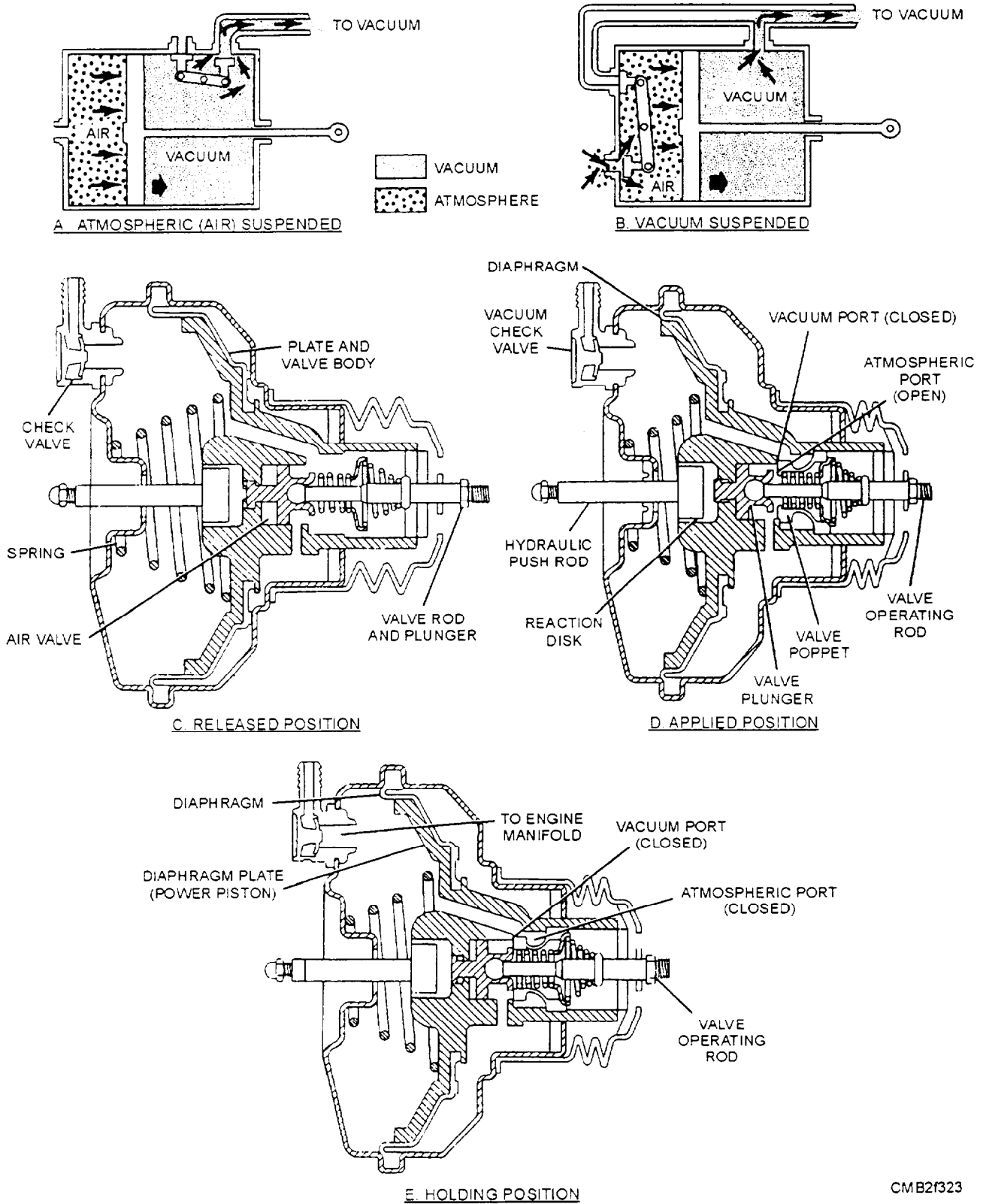

CMB2f323

Figure 7-22.—Vacuum power booster and operation.

It is impossible to create a perfect vacuum, but by pumping air from a container, it is possible to obtain a difference in pressure between the outside and inside of the container, or a partial vacuum. If the container

were suddenly opened, outside air would rush into the container to equalize the pressure. It is upon this principle that the power cylinder of a vacuum booster system operates.



The power brake operates during three phases of braking application—brakes released, brakes applied, and brakes holding. The operations of a typical vacuum-suspended power booster are as follows:

- **RELEASED POSITION** (fig. 7-22)—With the brakes fully released and the engine operating, the rod and plunger return spring moves the valve operating rod and valve plunger to the right. As this happens, the right end of the valve plunger is pressed against the face of the poppet valve, closing off the atmospheric port and opening the vacuum port. With the vacuum port opened, vacuum is directed to both sides of the diaphragm, and the return spring holds the diaphragm away from the master cylinder.

- **APPLIED POSITION** (fig. 7-22)—As the brake pedal is depressed, the valve operating rod moves to the left, which causes the valve plunger to move left also. The valve return spring is then compressed as the plunger moves and the poppet valve comes in contact with the vacuum port seat. As this happens, the vacuum port closes off. Continued application of the brake pedal causes the valve rod to force the valve plunger from the poppet, thereby opening the atmospheric port. Atmospheric pressure then rushes into the control vacuum chamber and applies pressure to the hydraulic pushrod.

- **HOLDING POSITION** (fig. 7-22)—As the operator stops depressing the brake pedal, the plunger will also stop moving. The reaction of the brake fluid transmitted through the reaction disc now will shift the valve plunger slightly to the right, shutting off the atmospheric port. As this position is held, both sides of the diaphragm contain unchanging amounts of pressure, which exerts a steady amount of pressure on the cylinder piston.

On many installations a vacuum reservoir is inserted between the power booster and the intake manifold. The purpose of the reservoir is to make vacuum available for a short time to the booster unit should the vehicle have to stop quickly with a stalled engine. A check valve in the reservoir maintains a uniform vacuum within the system should engine vacuum drop off. This check valve prevents vacuum from bleeding back to the intake manifold when manifold vacuum is less than the vacuum in the reservoir.

All modern power brakes retain some pedal resistance, permitting the operator to maintain a certain amount of pedal feel. For example, a light pressure upon the pedal will give a light braking force,

while heavy pressure upon the brake pedal will cause severe brake application. If the vacuum section of the power booster should fail, brake application can still be obtained by direct mechanical pressure on the master cylinder piston. However, the operator must apply a greater force to the brake pedal to achieve even minimal braking force.

The vacuum-hydraulic power booster, used in most passenger vehicles and light trucks, is of the integral type, so-called because the power booster and the master cylinder are combined in a single assembly. The most common integral types all use a single or tandem diaphragm (fig. 7-23) and are of the vacuum suspended type. The power unit uses a master cylinder constructed in the same manner as the conventional dual master cylinder.

If brake trouble is encountered, check the brake system in the same manner as for conventional brakes. When a vehicle has vacuum type power brakes, you should inspect the brake booster and vacuum hose. Make sure the vacuum hose from the engine is in good condition. It should not be hardened, cracked, or swollen. Also check the hose fitting in the booster. If the system is not performing properly, you should check the power booster for correct operation as follows:

- Stop the engine and apply the brakes several times to deplete the vacuum reserve in the system.
- Partly depress the brake pedal, and while holding it in this position, start the engine.
- If the booster is operating properly, the brake pedal will move downward slightly. If no action is felt, the booster is not functioning.

If the power unit is not giving enough assistance, check the engine vacuum. If engine vacuum is abnormally low (below 14 inches at idle), tune up the engine to raise the vacuum reading and again try the brakes. A steady hiss, when the brake pedal is depressed, indicates a vacuum leak, preventing proper operation of the booster.

Vacuum failure, which results in a hard pedal, may be due to a faulty check valve, a collapsed vacuum hose to the intake manifold, or an internal leak in the power booster.

A tight pedal linkage (insufficient pushrod clearance) will also result in a hard pedal. If this connection is free and the brakes still fail to release properly, the power booster must be replaced.

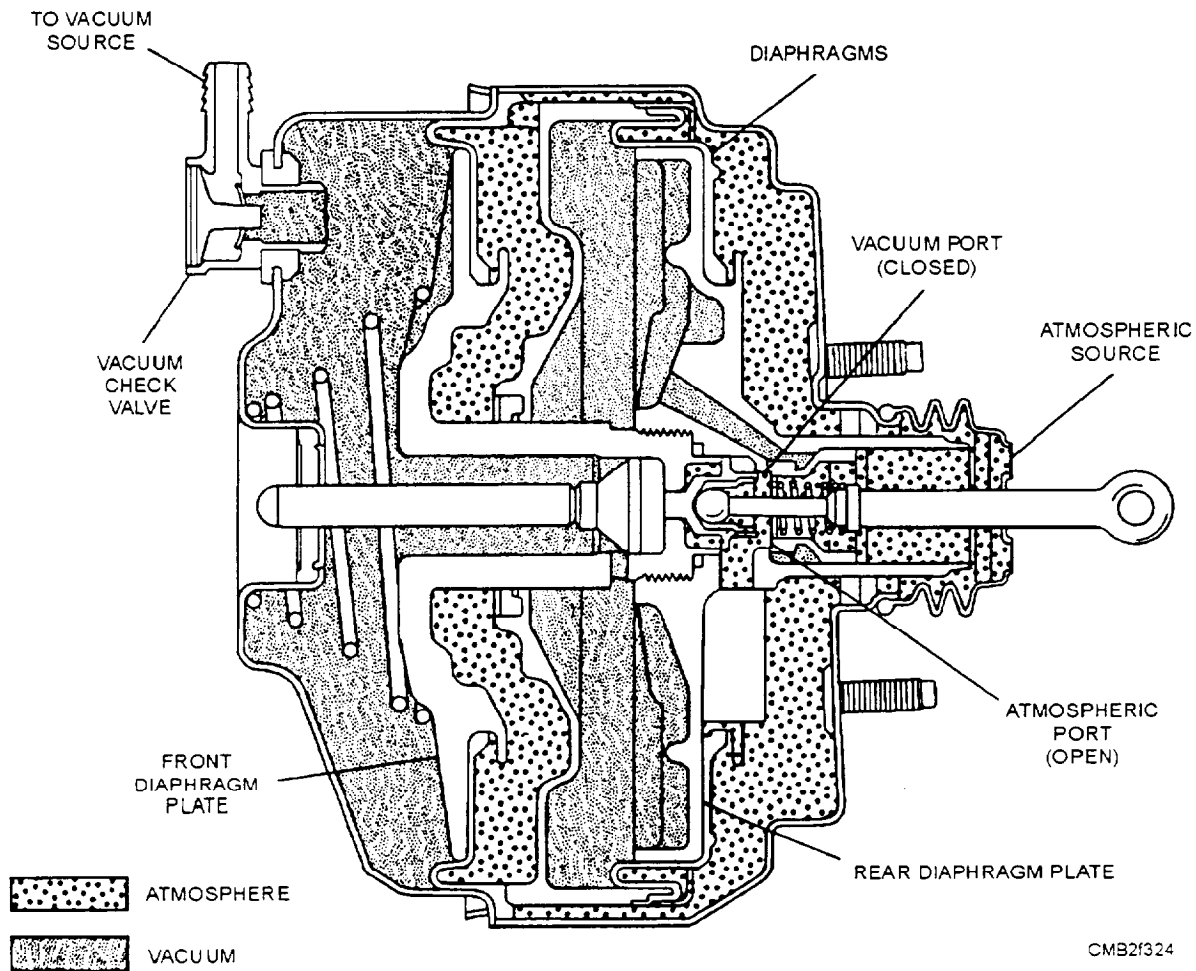

Figure 7-23.—Tandem-type booster.

In addition to hydraulic system problems, the brakes may fail to release as a result of a blocked passage in the power piston, a sticking air valve, or a broken air valve spring.

Any malfunction occurring in the power booster will require removing the booster from the vehicle for repair or replacement. Some power boosters may be rebuilt or repaired; others are sealed and cannot be disassembled. Should you have any questions concerning repairs on the power brake system you are working on, consult the manufacturer's service manual for proper procedures to follow when testing or repairing a unit.

### Hydraulic Boosters

The hydraulic-power booster, also called a hydroboost (fig. 7-24), is attached directly to the master cylinder and uses power steering pump pressure to assist the operator in applying the brake pedal. The hydraulic booster contains a spool valve that has an open center that controls the pump pressure

as braking occurs. A lever assembly has control over the valve position and the boost piston provides the necessary force that operates the master cylinder. See figure 7-25 for a parts breakdown of a booster assembly.

The hydroboost system has an accumulator built into the system. The accumulator, which is either spring-loaded or pressurized gas, is filled with fluid and pressurized whenever the brakes are applied. Should the power steering system fail because of lack of fluid or a broken belt, the accumulator will retain enough fluid and pressure for at least two brake applications.

### PARKING BRAKES

Parking/emergency brakes are essential to the safe operation of any piece of automotive or construction equipment. Parking brakes interconnected with service brakes are usually found on automotive vehicles (fig. 7-26). A foot pedal actuates this type of parking/emergency brake or a dash-mounted handle.

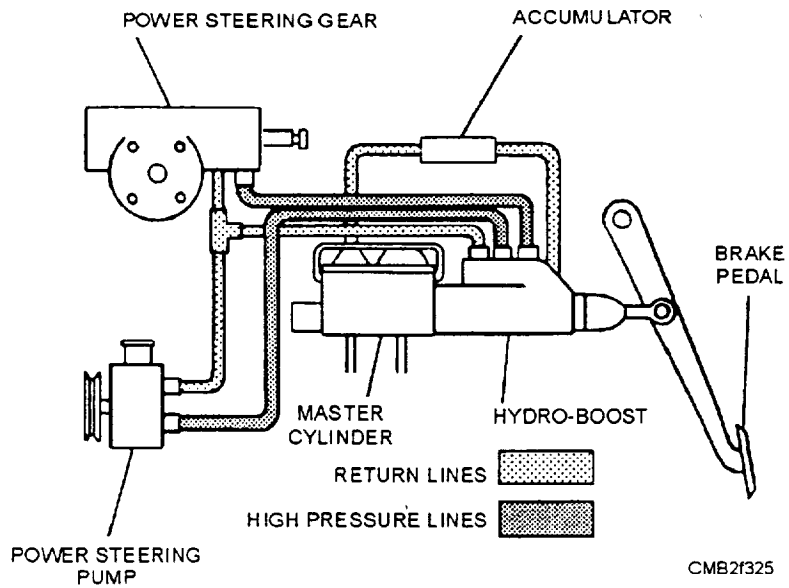

Figure 7-24.—Hydraulic power booster system.

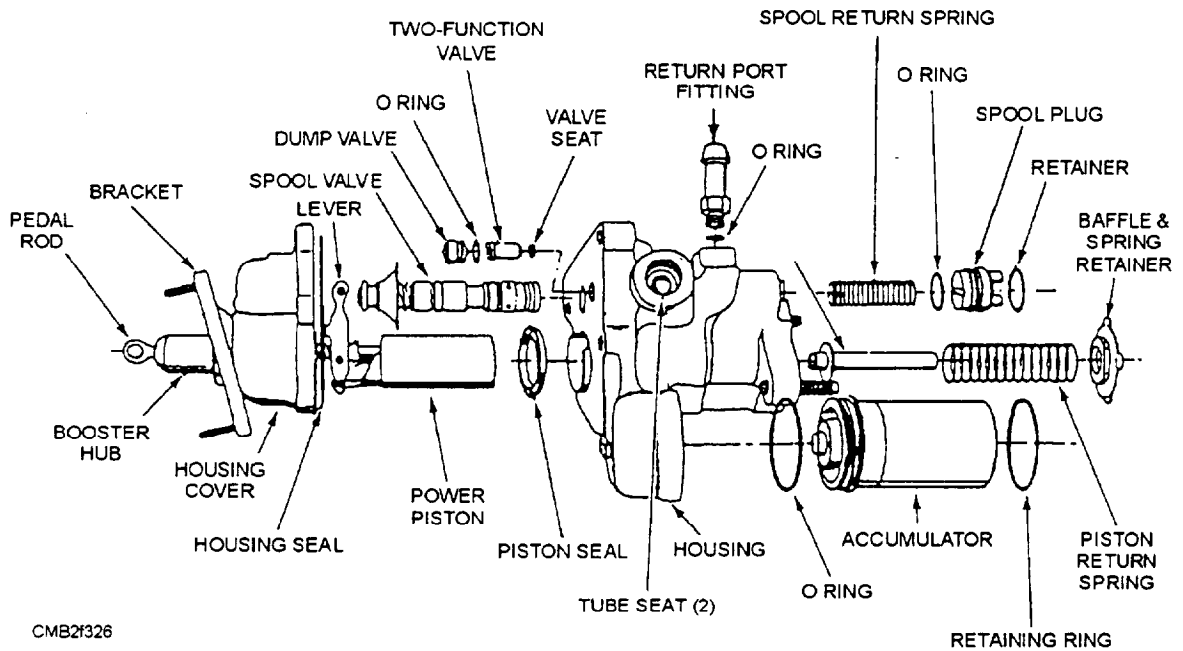

Figure 7-25.—Hydraulic power booster assembly.

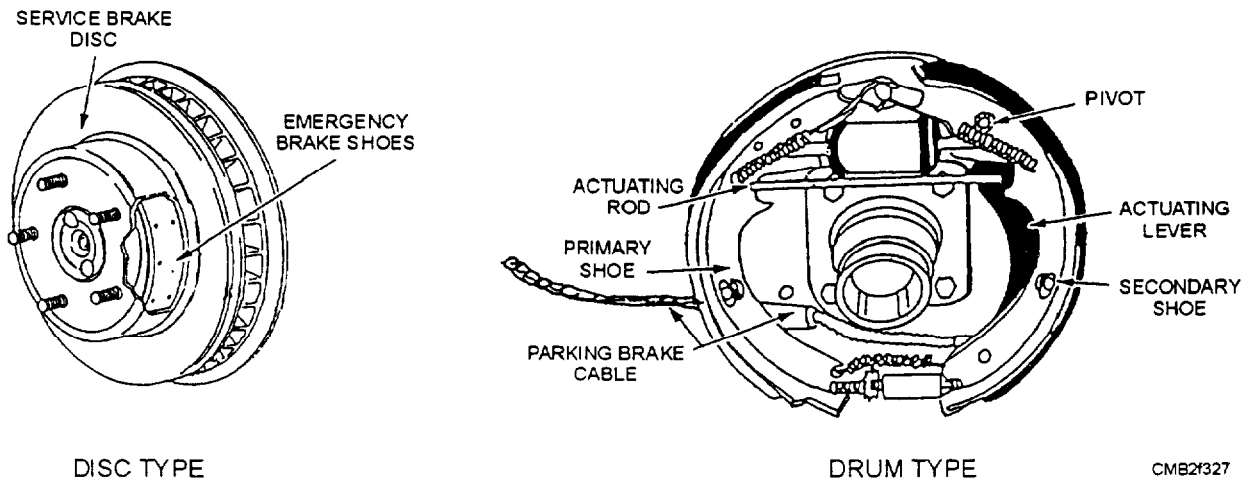

Figure 7-26.—Automotive type parking/emergency brakes, axle mounted.

They are connected through a linkage to an equalizer lever (fig. 7-27) rod assembly, and cables connected to the parking/emergency brake mechanism within the drums/discs (fig. 7-26) at the rear wheels.

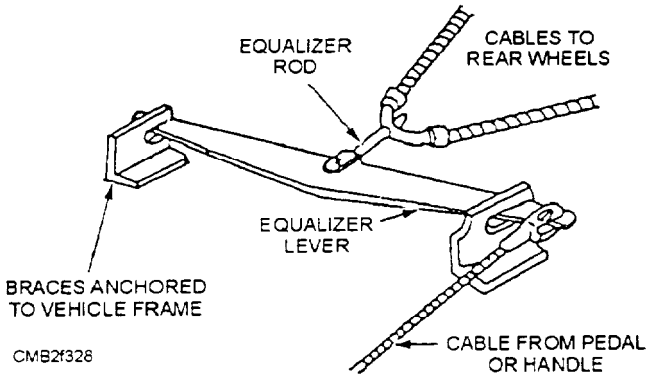

Figure 7-27.—Equalizer linkage.

Several types of parking/emergency brakes are manufactured for construction equipment, such as the external contracting, the drum, and the disc types (fig. 7-28). These are drive line brakes common to heavy construction equipment. They are usually mounted on the output shaft of the transmission or transfer case directly in the drive line.

Theoretically, this type of system is preferred for heavy equipment because the braking force is multiplied through the drive line by the final drive ratio. Also, braking action is equalized perfectly through the differential. There are some drawbacks to this system, however—severe strain is placed on the transmission system, and also the vehicle may move when being lifted since the differential is not locked out.

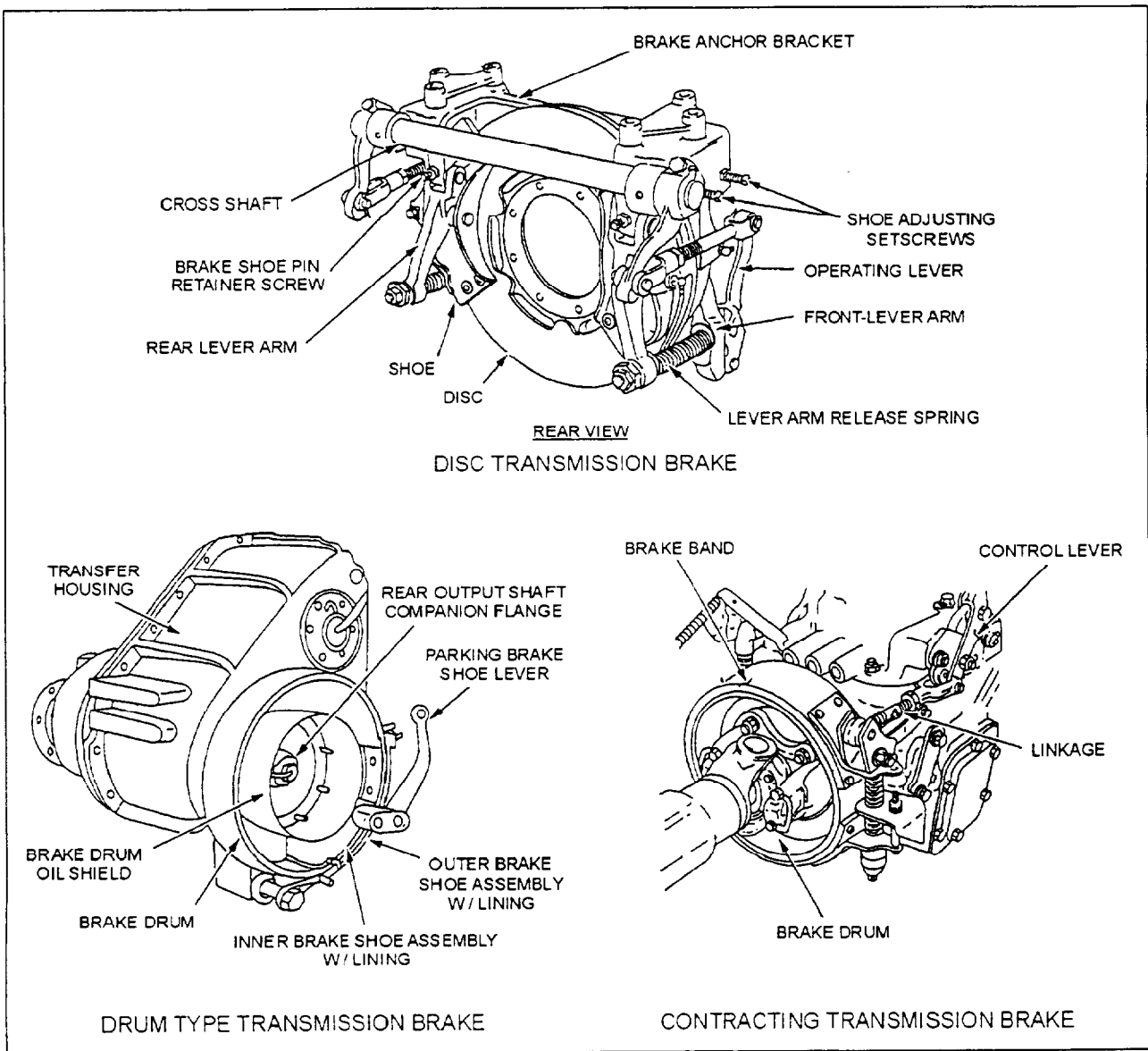

Figure 7-28.—Examples of drive line parking/emergency brakes, transmission mounted.

The parking/emergency brake must hold the vehicle on any grade. This requirement covers both passenger and commercial motor vehicles equipped with either the enclosed type brake at each rear wheel or a single brake mounted on the drive line. The *Federal Motor Carrier Safety Regulations Pocketbook*, par. 393-52. lists emergency brake requirements.

## **BRAKE SYSTEM INSPECTION**

Most vehicle manufacturers recommend periodic inspection of the brake system. This involves checking the fluid level in the master cylinder, brake pedal action, condition of the lines and hoses, and the brake assemblies. These checks are to be performed during the preventive maintenance (PM) cycle.

### **Checking Master Cylinder Fluid Level**

An important part of the brake system inspection is checking the level of the brake fluid. To check the fluid, remove the master cylinder cover, either by unbolting the cover or prying off the spring clip. The brake fluid level should be 1/4 inch from the top of the reservoir.

### **CAUTION**

Use only the manufacturer's recommended type of brake fluid. Keep grease, oil, or other contaminants out of the brake fluid. Contamination of the brake fluid can cause deterioration of the master cylinder cups, resulting in a sudden loss of braking ability.

### **Brake Pedal Action**

A quick and accurate way to check many of the components of the brake system is by performing a brake pedal check. Applying the brake pedal and comparing its movement to the manufacturer's specifications does this. The three brake pedal application distances are as follows:

- **BRAKE PEDAL FREE PLAY**, which is the amount of pedal movement before the beginning of brake application. It is the difference between the "at rest" and initially applied position. Free play is required to prevent brake drag and overheating. If pedal free play is NOT correct, check the adjustment of the master cylinder pushrod. If this adjustment is correct, check for a worn pedal bushing or a bad return spring, which can also increase pedal free play.

- **BRAKE PEDAL HEIGHT**, which is the distance from the pedal to the floor with the pedal at rest. If the height is incorrect, there may be worn pedal bushings, weak return springs, or a maladjusted master cylinder pushrod.

- **BRAKE PEDAL RESERVE DISTANCE**, which is measured from the floor to the brake pedal with the brake applied. The average brake pedal reserve distance is 2 inches for manual brakes and 1 inch for power brakes. If the reserve distance is incorrect, check the master cylinder pushrod adjustment. Also, there may be air in the system or the automatic brake adjusters may not be working.

### **Brake System Leaks**

If the fluid level in the master cylinder is low, you should check the system for leaks. Check all brake lines, hoses, and wheel cylinders. Brake fluid leakage will show up as a darkened, damp area around one of the components.

### **Checking Brake Assemblies**

When inspecting the brake system, remove one of the front and rear wheels. This will let you inspect the condition of the brake linings and other components.

**INSPECTING DISC BRAKES.**—Areas to check when inspecting disc brakes are the pads, the disc, and the caliper. You should check the thickness of the brake pad linings. Pads should be replaced when the thinnest (most worn) part of the lining is approximately 1/8 inch thick.

Check the caliper for fluid leakage at the piston seal and missing or damaged clips/springs. The disc should be checked for damage, such as heat cracks, heat checks (overheating causes small hardened and cracked areas), and scoring. Wheel bearings should be checked and adjusted if necessary. To check for rattles, strike the caliper with a soft-faced rubber mallet. To repair any of these problems, consult the manufacturer's service manual.

**INSPECTING DRUM BRAKES.**—Areas to check when inspecting drum brakes are the brake shoes, the brake drums, the wheel cylinders, and other related parts. Once the wheel is removed, you must remove the brake drum that will expose all parts requiring inspection.

The brake shoe linings must NOT be worn thinner than 1/16 inch. They also should NOT be glazed or coated with grease, brake fluid, or differential fluid. Any of these conditions require lining replacement.

Check the brake drum for cracks, heat cracks, heat checks, hard spots, scoring, or worn beyond specifications. Damaged drums may be machined (turned) as long as they still meet the manufacturer's specifications. Badly damaged or worn drums must be replaced.

To check the wheel cylinder for leakage, pull back the cylinder boots. If the boot is full of fluid, the wheel cylinder should be rebuilt or replaced. Also, check the return springs and the automatic adjusting mechanism.

## **SERVICING THE MASTER CYLINDER**

When major brake service is being performed, the master cylinder is to be inspected for proper operation. A faulty master cylinder usually leaks externally out the rear piston or leaks internally. You are able to detect external brake fluid leaks by checking the master cylinder boot for fluid or dampness on the firewall. When the leak is internal, the brake pedal will slowly move to the floor. Inoperative valves in the master cylinder are also a reason for service.

To remove the master cylinder, disconnect the brake lines from the master cylinder using tubing wrenches. With the brake lines disconnected, unbolt the master cylinder from the brake booster or firewall. In some cases, the pushrod must be disconnected from the brake pedal.

Many shops, however, simply replace a bad master cylinder with a factory rebuild or a new one. A replacement master cylinder is normally cheaper than the labor cost and parts for an in-shop rebuild.

### **NOTE**

NCF units require replacement of faulty master cylinders. Rebuilding of master cylinders is NOT authorized.

To rebuild a master cylinder, drain the fluid from the reservoir. Disassemble the master cylinder following the instructions in the manufacturer's service manual. After disassembly, clean the parts in brake fluid or a recommended cleaner.

### **WARNING**

Do NOT clean the hydraulic parts of the brake system with conventional parts cleaners. They can destroy the rubber cups in the brake system. Only use brake fluid or a manufacturer's suggested cleaner (denatured alcohol, for example).

If the cylinder is not pitted, scored, or corroded badly, it may be honed using a cylinder hone. When the cylinder is honed, the hone is ran ONLY once in and out. After honing, measure the piston-to-cylinder clearance, using a telescoping gauge and an outside micrometer or a narrow (1/8" to 1/4" wide) 0.006" feeler gauge. When a feeler gauge is used, if the gauge can be inserted between the cylinder wall and the piston, the master cylinder must be replaced. The cylinder must NOT be tapered or worn beyond the manufacturer's specifications. Replace the master cylinder if the cylinder is not in perfect condition after honing.

Blow-dry all parts with low-pressure compressed air. Blow out the ports and check for obstructions. Lubricate all parts with the recommended brake fluid and assemble the master cylinder, using the manufacturer's service manual.

After the master cylinder is reassembled, it is good practice to bench bleed a new or rebuilt master cylinder before installation on the vehicle. A master cylinder is bled to remove air from the inside of the cylinder. Bench bleeding procedures are as follows:

- Mount the master cylinder in a vise
- Install short sections of brake line and bend them back into each reservoir
- Fill the reservoir with approved brake fluid
- Pump the piston in and out by hand until air bubbles no longer form in the fluid
- Remove the brake lines and install the reservoir cover

Once the master cylinder has been bench bled, it is ready to be reinstalled on the vehicle. Bolt the master cylinder to the booster or firewall. Check the adjustment of the pushrod if there is a means of adjustment provided. Without cross threading the fittings, screw the brake lines into the master cylinder, and lightly snug the fittings. Then bleed (remove air from) the system. Tighten the brake line fittings. Refill the reservoir to the proper level and check brake pedal fall. Last but not least, test the vehicle.

## **SERVICING DRUM BRAKES**

You should understand the most important methods for servicing a drum brake. However, specific procedures vary and you should always consult the manufacturer's service manual. Brake service is required anytime you find faulty brake components. A leaking wheel cylinder, worn linings, scored drum, or

other troubles require immediate repairs. A complete drum brake service involves the following:

- Removing, cleaning, and inspecting parts from the backing plate
- Replacing brake shoes
- Resurfacing brake drums
- Replacing or rebuilding wheel cylinders
- Lubricating and reassembling brake parts
- Readjusting, bleeding, and testing the brakes

### Servicing Wheel Cylinders

Normally, faulty wheel cylinders are detected when fluid leaks appear or the pistons stick in the cylinders, preventing brake application. Many shops service the wheel cylinders anytime the brake linings are replaced.

#### NOTE

NCF units require replacement of faulty wheel cylinders. Rebuilding of wheel cylinders is NOT authorized.

To rebuild a wheel cylinder, remove the boots, the pistons, the cups, and the springs. Most wheel cylinders can be disassembled and rebuilt on the vehicle. However, many manufacturers recommend that the wheel cylinder be removed from the backing plate and serviced on the bench. This makes it easier to properly clean, inspect, and reassemble. A rebuild normally involves honing the cylinder and replacing the cups and boots.

It is important that the cylinder be in good condition. Inspect the cylinder bore for signs of pitting, scoring, or scratching. Any sign of pitting, scoring, or scratching requires cylinder replacement.

A brake cylinder hone is used when honing is required. With the cylinder hone attached to an electric drill, lubricate the hone with brake fluid and insert into the cylinder. Turn the drill on and move the hone back and forth one time ONLY. The cylinder bore must not be honed more than 0.003 inch larger than the original diameter. Replace the cylinder if the scoring cannot be cleaned out or if the clearance between the bore and pistons is excessive.

#### CAUTION

When honing a wheel cylinder, do not let the hone pull out of the cylinder. The spinning hone can fly apart causing bodily harm. Wear eye protection.

After honing, clean the cylinder thoroughly using clean rags and recommended brake fluid. Make sure the cylinder is clean and in perfect condition before reassembly. The slightest bit of grit or roughness can cause cup leakage.

When reassembling the wheel cylinder, make sure the new wheel cylinder cups are the same size as the originals. Cup size is normally printed on the face of the cup. Lubricate all parts with clean brake fluid and reassemble.

#### NOTE

Never allow any grease or oil to contact the rubber parts or other internal components. Grease or oil will cause the rubber parts to swell, which will lead to brake failure.

### Replacing Brake Shoe Linings

To replace the brake shoes, first remove the wheel and brake drum. With the drum removed, note how the springs and retainers are installed before attempting to remove the shoes from the backing plate. This will assist you during reassembly.

If hydraulic brakes are being repaired, install a wheel cylinder clamp (fig. 7-29) to prevent the pistons from coming out of the wheel cylinder. Next, remove the retracting springs with brake spring pliers or a removal and installation tool (fig. 7-30). The brake

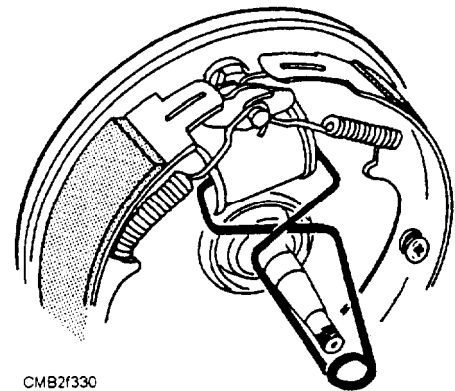

CMB2f330

Figure 7-29.—Wheel cylinder clamp in use.

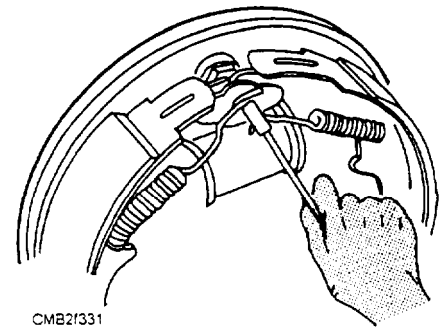

CMB2f331

Figure 7-30.—Removal of the brake return springs.

shoe retainers must be removed next. Figure 7-31 shows one type being removed with a pair of ordinary combination pliers. Heavy-duty brake shoes are mounted on separate anchor pins. Some of these installations require the removal of the anchor pins, while others require the removal of clips on the end of these pins before the brake shoes can be removed.

On light-duty applications, you can now grasp the shoes (fig. 7-32) and lift them off the backing plate. After they are removed, allow the shoes to move together (fig. 7-33). This allows easy removal of the spring and adjusting screw assembly. Disassemble the adjusting screw and lubricate with a high-temperature lubricant.

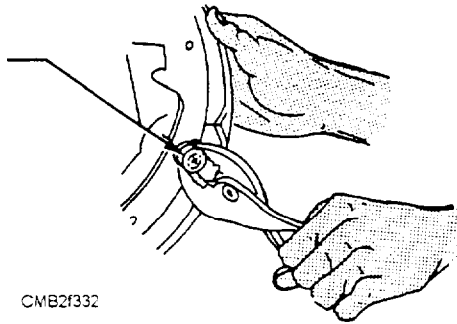

Figure 7-31.—Removal of a brake shoe retainer.

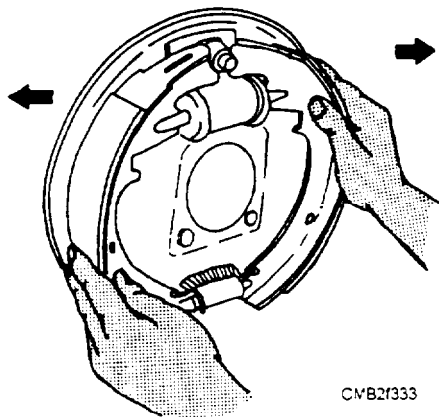

Figure 7-32.—Removing shoes from the backing plate.

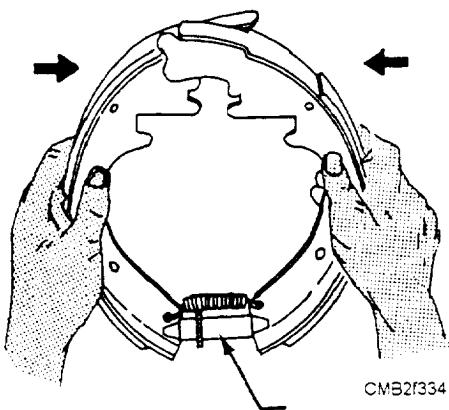

Figure 7-33.—Removing adjusting screw assembly.

If the lining is riveted and is to be replaced, you should mark the front and rear shoe. This action will aid in reassembly. Wipe off the backing plate thoroughly with a rag. If the backing plate is coated with brake fluid or axle lubricant, wash it with an approved cleaner. Once the backing plate is clean, apply a light coat of high-temperature lubricant to the raised pads on the backing plate. This will keep the shoes from squeaking after they are reassembled. Avoid using too much lubricant or the linings can become contaminated and ruined.

New linings are secured to the shoes by riveting or bonding. Bonded brake linings are supplied with the linings already attached to the shoes. At some activities, the old shoes must be exchanged when issued new shoes from the parts room. Linings that require rivets to attach the linings to the shoes are provided in kits. These kits provide enough linings and rivets for one or more wheels. The linings are predrilled and countersunk for the rivets and arced to match the brake shoes.

Some shops have specialized equipment to remove and replace the riveted linings. However, if the equipment is not available, the old linings can be removed with a drill and oversized bit, punch, and hammer. Take care not to enlarge the rivet holes in the shoes. If the rivet holes are enlarged, the shoe should be discarded.

Most NCF shops have a device for installing rivets. This device comes with adapters for use with various size rivets. When installing rivets, you always start in the center of the lining and work alternately to each end. Make sure the rivets are tight enough to hold the lining securely without splitting the lining at the rivet holes.

For installation of the new shoes, refer to the manufacturer's service manual. Your service manual will have illustrations for the particular brake design being serviced. Use them to ensure all parts are positioned correctly, on the backing plate. When reassembling the brake assemblies, ask yourself the following questions:

- Are the wheel cylinders in perfect condition and assembled properly?
- Did I lubricate the backing plate and star wheel?
- Is the primary (smaller) lining facing the front of the vehicle and the secondary (larger) lining facing the rear?



- Are the brake shoes centered on the backing plate and contacting the anchor pin correctly?
- Are all springs installed properly?
- Does the automatic adjusting mechanism work?
- Are the linings perfectly clean (sand if needed)?
- Do I need to bleed the brakes?

### Servicing Brake Drums

With the drum removed, inspect the shoes to determine the condition of the drum. For instance, if the linings are worn thin on one side, the drums are likely to be tapered or bell-shaped. Linings with ridges in their contact surfaces point out the need for resurfacing (turning) the drum to remove the matching ridges.

Resurfacing is needed when the drum is scored, out-of-round, or worn unevenly. Some shops resurface a drum anytime the brake linings are replaced, others only when needed. Drums are resurfaced using a lathe in the machine shop of an NMCB and at some shore installations. Commercial brake drum lathes can be found in some shops. Make sure you know how to operate the lathe before attempting to resurface a drum. Using the wrong procedures will damage the drum and possibly deadline the vehicle.

Before resurfacing the drum, check the specifications that are cast into the drum (fig. 7-34) or are provided in the maintenance manual. These specifications tell you the maximum amount of surface material that can be removed from the drum and still provide adequate braking. Typically, a brake drum should not be more than .060 inch oversize. For example, a drum that is 9 inches in diameter, when new, must not be over 9.060 after resurfacing. To measure brake drum diameter, use a special brake drum micrometer (fig. 7-35). It will measure drum

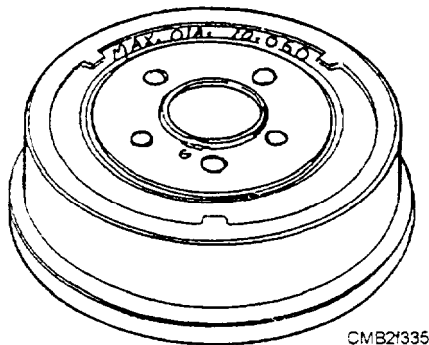

Figure 7-34.—Example of specification cast into a brake drum.

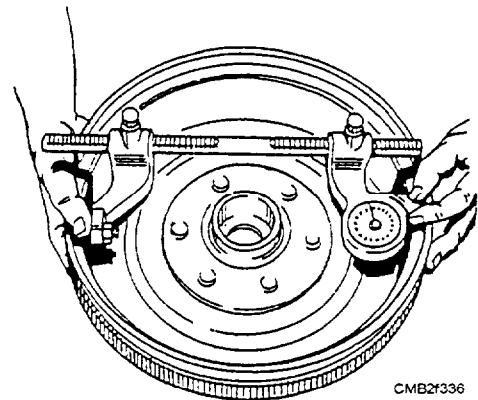

Figure 7-35.—Using a drum micrometer to measure a brake drum.

diameter quickly and accurately. Replace the drum if it is worn beyond specifications.

For maximum braking efficiency after the drums have been resurfaced, the arc of the shoes must match the drums. This means that the linings must be ground to match the curvature of the drum when it is resurfaced. There should be a small clearance between the ends of the lining and the drum. The shoes should rock slightly when moved in the drum. If the center of the linings is not touching the drum, the linings should be arced (ground). Shops equipped with a commercial brake lathe have a special attachment to perform this task. If no attachment is available, the shoes can be installed but the brakes will not become fully effective until the linings wear enough to match the braking surface of the drum. Frequent adjustments will be needed until they wear sufficiently.

### SERVICING DISC BRAKES

All disc brake services begin with sight, sound, and stopping test. The feel of the brake pedal adds a check on the condition of the hydraulic system.

Stopping the vehicle will indicate whether the brakes pull in one direction, stop straight, or require excessive effort to stop. Listening while stopping permits a fair diagnosis of braking noises, such as rattles, groans, squeals, or chatters. Visually inspecting the parts provides valuable information on the condition of the braking system.

A complete disc brake service typically involves four major operations, which are as follows:

- Replacing worn brake pads
- Rebuilding the caliper assembly
- Resurfacing the brake discs
- Bleeding the system

Depending on the condition of the parts, the mechanic may need to do one or more of the operations. In any case, you must make sure the brake assembly is in sound operating condition.

## Disc Brake Pad Replacement

Disc brakes have flat linings bonded to a metal plate or shoe. The pad is not rigidly mounted inside the caliper assembly; thus, it is said to float. These pads are held in position by retainers or internal depressions (pockets machined into the caliper).

A visual inspection on the condition of the pads can be made after the wheel and tire is removed. The inner shoe and lining can be viewed through a hole in the top of the caliper, whereas the outer shoe and linings can be viewed from the end of the caliper.

A good rule in determining the need for pad replacement is to compare lining thickness to the thickness of the metal shoe. If the lining is not as thick as the metal shoe, it should be replaced. The basic steps for disc brake service are as follows:

1. Siphon two thirds of the brake fluid from the master cylinder. This action prevents fluid overflow when the caliper piston is pushed back.
7. Remove the caliper guide pins that holds the caliper to the adapter. In typical applications, positioners and bushings will come off with the pins.
3. Lift the caliper off the adapter and away from the rotor. Do NOT let the caliper hang by the brake hose. Hook or tie the caliper to a suspension member. This will allow the rotor to be tested and inspected.
4. Remove old pads from the caliper and adapter. Note the position of antirattle clips because they may be reused if they are in good condition.
5. Using a C-clamp or large screwdriver, force the piston back into the caliper. This action will open the caliper wide enough for new, thicker pads.
6. Install the antirattle clips on the new pads. Fit the pads back into the caliper.
7. Slide the caliper assembly over the rotor. Assemble the caliper mounting hardware in reverse order of disassembly. Make sure all bolts are torqued to the manufacturer's specifications.

8. After new pads are installed, road test the vehicle to make sure that the brakes are operating properly and also seat the new pads. Several (3 to 3) heavy braking applications will work.

## NOTE

It is acceptable to service just the rear or front disc brakes. However, NEVER service only the left or right brake assemblies; always replace both sets to assure equal braking action.

Since disc brake systems vary, consult the vehicle manufacturer's service and repair manuals for specific details on the type of disc brakes you are working on.

## Servicing Caliper Assemblies

When a caliper is frozen, leaking, or has extremely high mileage, it is to be serviced. Servicing disc brake caliper assemblies involve the replacement of the piston, seals, and dust-boots. To perform this type of service, it is necessary to remove the caliper assembly from the vehicle. Basic steps for servicing the caliper assemblies are as follows:

1. Remove the piston from the caliper by using air pressure to push the piston from the cylinder. Keep your fingers out of the way when using compressed air to remove the pistons from the caliper. Serious hand injuries can result.
2. With the piston removed, pry out the old dust boot and seal from the caliper. Keep all parts organized on the workbench. Do not mix up right and left side or front and rear parts.
3. Check the caliper cylinder wall for scoring, pitting, and wear. Light surface imperfections can usually be cleaned with a cylinder hone or emery cloth. When honing, use brake fluid to lubricate the hone. If excessive honing is required, replace the caliper.
4. Check the piston for wear and damage. If any problems are found, replace the piston. The piston and cylinder are critical and must be in perfect condition.
5. Clean all parts with an approved cleaner. Wipe the parts with a dry, clean rag. Then coat the parts with brake fluid.
6. Assemble the caliper in reverse order of disassembly. Using new seals and boots, fit the

new seal in the cylinder bore groove. Work the seal into its groove with your fingers. Install the new boot in its groove. Coat the piston with more brake fluid. Spread the boot with your fingers and slide the piston into the cylinder. The caliper can now be reinstalled on the vehicle.

Carefully follow the procedures given in the manufacturer's service and repair manuals for specific details when removing, repairing, and reinstalling disc brake caliper assemblies.

### Brake Disc (Rotor) Service

It is important to check the condition of the brake disc when servicing the brake system. Vehicle manufacturers provide specifications for minimum disc thickness and maximum disc runout. The disc must also be checked for scoring, cracking, and heat checking. Disc resurfacing is required to correct runout, thickness variation, or scoring.

**MEASURING DISC THICKNESS.**—To measure disc thickness, use an outside micrometer. Disc thickness is measured across the two friction surfaces in several locations. Variation in disc thickness indicates wear. Compare your measurements to the manufacturer's specifications.

Minimum disc thickness will sometimes be printed on the side of the disc (fig. 7-36). If not, refer to the manufacturer's service manual or a brake specification chart. If disc thickness is under specifications, replace the disc, because a thin disc cannot dissipate heat properly and may warp or fail during service.

**BRAKE DISC RUNOUT.**—The amount of side-to-side movement, measured near the outer friction surface of the disc, is known as brake disc runout. Runout is measured using a dial indicator.

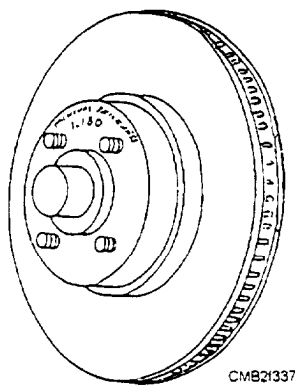

Figure 7-36.—Example of minimum thickness specification cast into a brake disc.

Using a magnetic base, attach the dial indicator to the hub. Position the dial indicator so it touches the face of the disc. Rotate the disc by hand and read the indicator.

Compare the indicator reading to factory specifications. Typically, disc runout should not exceed .004 inch. If runout is beyond specifications, resurface the disc to its true friction surface.

**RESURFACING A BRAKE DISC.**—When a disc is in good condition, most manufacturers do NOT recommend disc resurfacing. Disc resurfacing is done when absolutely necessary.

When using a brake lathe to resurface a brake disc, you use the appropriate spacers and cones to position the disc on the arbor of the machine. Wrap a spring or rubber damper around the disc to prevent vibration. Follow the directions provided with the brake lathe.

### WARNING

Do not attempt to operate a brake lathe without first obtaining proper training. Damage to the machine or injury to the operator can occur as a result of incorrect operating procedures.

Only take off enough metal to true the disc. Then without touching the machined surfaces with your fingers, remove the disc. This prevents body oil from penetrating the machined surfaces. Check the disc for thickness and reinstall on the vehicle.

### BRAKE SYSTEM BLEEDING

Brake system bleeding is the use of fluid pressure to force air from the system. The brake system must be free of air to function properly. Air in the system will compress, causing a springy or spongy brake pedal. Air may enter the system any time a hydraulic component (wheel cylinder, master cylinder, hose, or brake line) is disconnected or removed. There are two methods of bleeding brakes—manual bleeding and pressure bleeding.

#### Manual Bleeding

Manual bleeding uses master cylinder pressure to force fluid and trapped air out of the system. To bleed the system, proceed as follows:

- Fill the master cylinder reservoir with brake fluid to 1/4 inch from the top, and keep it full during bleeding operations.

- Attach a short length of a rubber hose to the wheel cylinder bleeder screw and allow the other end of the hose to be submerged in a jar halfway filled with brake fluid (fig. 7-37).
- Have an assistant push on the brake pedal to apply pressure on the brake system. It may be necessary to pump the brake six to seven times to build up pressure in the system.
- Open the bleeder screw while watching for air bubbles in the fluid located in the jar.
- Close the bleeder screw and tell your assistant to release the brake pedal. Repeat this procedure until no air bubbles come out of the hose.

Bleed one wheel cylinder at a time. Do the one farthest away from the master cylinder first and work your way to the closest. This ensures that all the air possible can be removed at the first bleeding operation.

### Pressure Bleeding

Pressure bleeding of a brake system is preferred to the method just described but requires equipment of the type shown in figure 7-38. Pressure bleeding a brake system is done using air pressure trapped inside a metal air tank (bleeder ball). Pressure bleeding is quick and easy because of the following:

- It does not require an assistant.
- It maintains a constant pressure in the system.
- It keeps the master cylinder full during bleeding

To pressure bleed the system, proceed as follows:

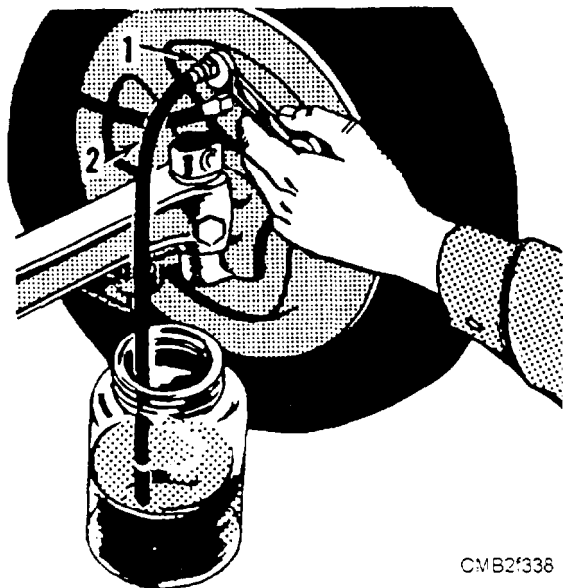

Figure 7-37.—Manual bleeding brake lines: (1) Bleeder screw; (2) Bleeder hose.

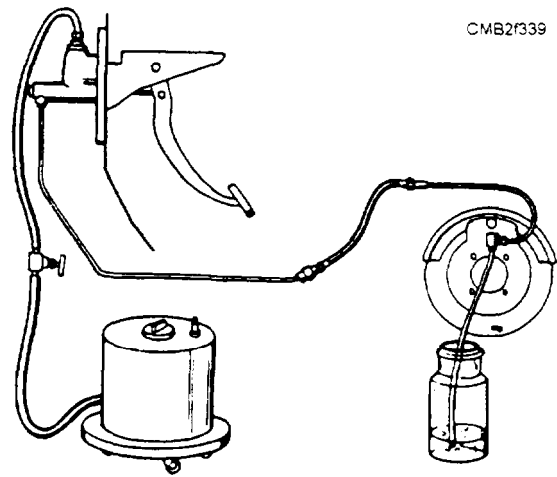

Figure 7-38.—Pressure bleeding a brake system.

- Pour enough brake fluid in the bleeder ball to reach the prescribed level. Charge the ball with 10 to 15 psi of air pressure.
- Fill the master cylinder with brake fluid. Install the adapter and hose on the master cylinder. Open the valve on the hose.

### NOTE

A special pressure-bleeding adapter is required on master cylinders using a PLASTIC RESERVOIR. Use an adapter that seals over the ports in the bottom of the master cylinder. This will avoid possible reservoir damage.

- Attach a bleeder hose to the farthest wheel cylinder bleed screw. Submerge the free end of the hose in a glass container halfway filled with brake fluid.
- Loosen the bleed screw. When fluid coming from the submerged end of the hose is free of air bubbles, close off the bleed screw and remove the bleeder hose. Repeat bleeding operation on the other wheel cylinders in proper order.

When the bleeding operation is completed, close the valve at the bleeder ball hose and disconnect the bleeder from the master cylinder. Check the brake fluid level in the reservoir, ensuring it is within 1/4 inch from the top and install the master cylinder cover.

### REVIEW 1 QUESTIONS

- Q1. The time frame between the instant the operator decides to apply the brakes and the moment the brake system is activated is known by what term?

- Q2. What term is used to refer to the comparison of front-wheel to rear-wheel braking effort?
- Q3. Typically, what percentage of the braking does the rear brake handle?
- Q4. What component of a hydraulic brake system converts the force of an operator's foot into hydraulic pressure?
- Q5. In a vehicle using a dual master cylinder, what type of system operates the brake assemblies on opposite corners?
- Q6. What component in a hydraulic brake system is used where a single brake line feeds two wheel cylinders?
- Q7. What type of self-adjusting system uses braided steel cable?
- Q8. Disc brakes use servo actions. (T/F)
- Q9. What are the three types of brake shoes?
- Q10. What component of a disc brake system is a nonrotating unit?
- Q11. Why is a metering valve used?
- Q12. Describe a combination valve.
- Q13. What component of an ABS system uses a wheel speed sensor signal to operate the hydraulic actuator?
- Q14. What component of an ABS system is mounted on each spindle or hub?
- Q15. A hydroboostpower brake system uses pressure from the power steering pump. (T/F)
- Q16. What are the three brake pedal application distances?
- Q17. At what thickness should disc brake pads be replaced?
- Q18. What action should be taken before installing a new master cylinder on a vehicle?
- Q19. What device is used to measure brake drum diameter?
- Q20. The amount of side-to-side movement of a brake disc is known by what term?
- Q21. How much metal is to be removed when resurfacing a brake disc?
- Q22. When pressure bleeding a brake system, what is the charging pressure of the bleeder ball?

## AIR BRAKE SYSTEM

**Learning Objective:** Describe the operation, terms, and component functions of an air brake system. Describe the procedures for servicing an air brake system.

Unlike liquids, gases are compressed easily. If a gas, such as air, is contained and a force applied to it, it is compressed and has less volume. Placing a weight on a piston that fits in the container can exert such a force. The air that originally filled the entire container is pressed into only a portion of the container due to the force of the weight upon it. The pressure of the compressed air, resulting from the force exerted upon it by the weight, will be distributed equally in all directions just as it is in a liquid.

An air brake system performs the following basic actions:

- An air pump or compressor driven by the engine is used to compress air and force it into a reservoir where it is forced under pressure and made available for operating the brakes.
- Air under pressure in the reservoir is released to the brake lines by an air valve operated by the brake pedal.
- This released air goes to brake chambers (located at each wheel) that contains a flexible diaphragm. Against this diaphragm is a plate that is connected directly to the mechanism on the wheel brakes by linkage.
- The force of the compressed air admitted to the brake chamber causes the diaphragm to move the plate and operate the brake shoes through the linkage.

Considerable force is available for braking because the operating pressure may be as high as 110 psi. All brakes on a vehicle, and on a trailer when one is used, are operated together by means of special regulating valves. A diagram of a typical air brake system is shown in figure 7-39.

## COMPRESSOR, GOVERNOR, AND UNLOADER ASSEMBLY

The COMPRESSOR is driven from the engine crankshaft or one of the auxiliary shafts. The three common methods of driving the compressor from the engine are gear, belt, and chain. The compressor may be lubricated from the engine crankcase or self-lubricating. Cooling may be either by air or liquid

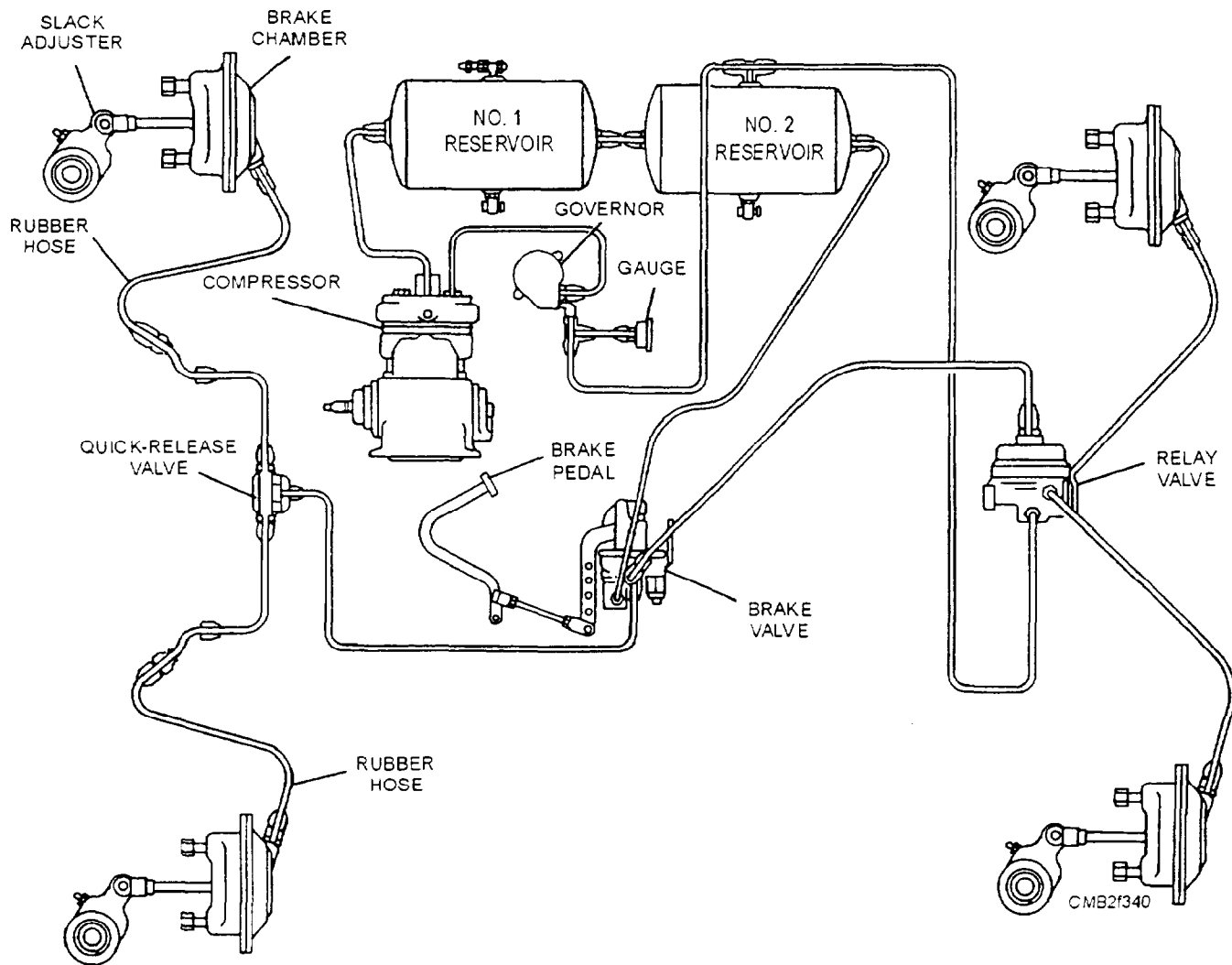

Figure 7-39.—Typical air brake system.

from the engine. Compressors, having a displacement of approximately 7 cubic feet per minute (cfm), have two cylinders, while those with a displacement of 12 cfm have three cylinders.

The reciprocal air compressor (fig. 7-40) operates continuously while the engine is running, but the governor controls the actual compression. The operation of the compressor is as follows:

- The partial vacuum created on the piston downstroke draws air through the air strainer and intake ports into the cylinder.
- As the piston starts its upstroke, the intake ports are closed off, and the air trapped in the cylinder is compressed.
- The pressure developed lifts the discharge valve, and the compressed air is discharged to the reservoirs. As the piston starts its downstroke, pressure is relieved, closing the discharge valve.

The purpose of the compressor GOVERNOR is to maintain the air pressure in the reservoir between the maximum pressure desired (100 to 110 psi) and the minimum pressure required automatically for safe operation (80 to 85 psi) by controlling the compressor unloading mechanism.

In the type O-1 governor (fig. 7-41) air pressure from the reservoir enters the governor through the strainer and is always present below the tower valve and in the spring tube. As the air pressure increases, the tube tends to straighten out and decrease pressure on the valve.

When the reservoir air pressure reaches the cutout setting of the governor (100 to 110 psi), the spring load of the tube on the tower valve has been reduced enough to permit air pressure to raise the tower valve off its seat. This movement of the lower valve raises the upper valve to its seat, which closes the exhaust port. Air then flows up through the small hole in the lower

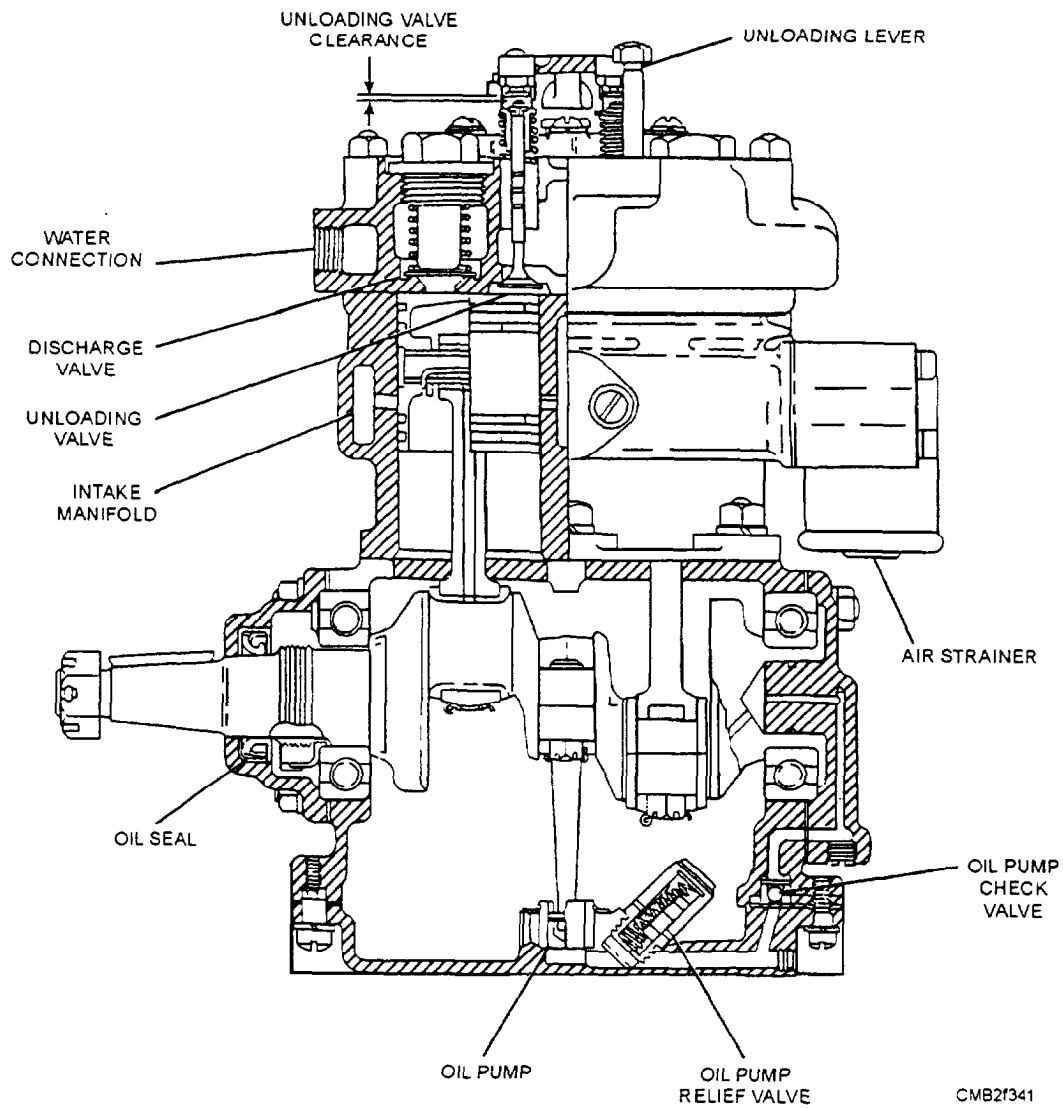

Figure 7-40.—Typical two-cylinder reciprocal air compressor.

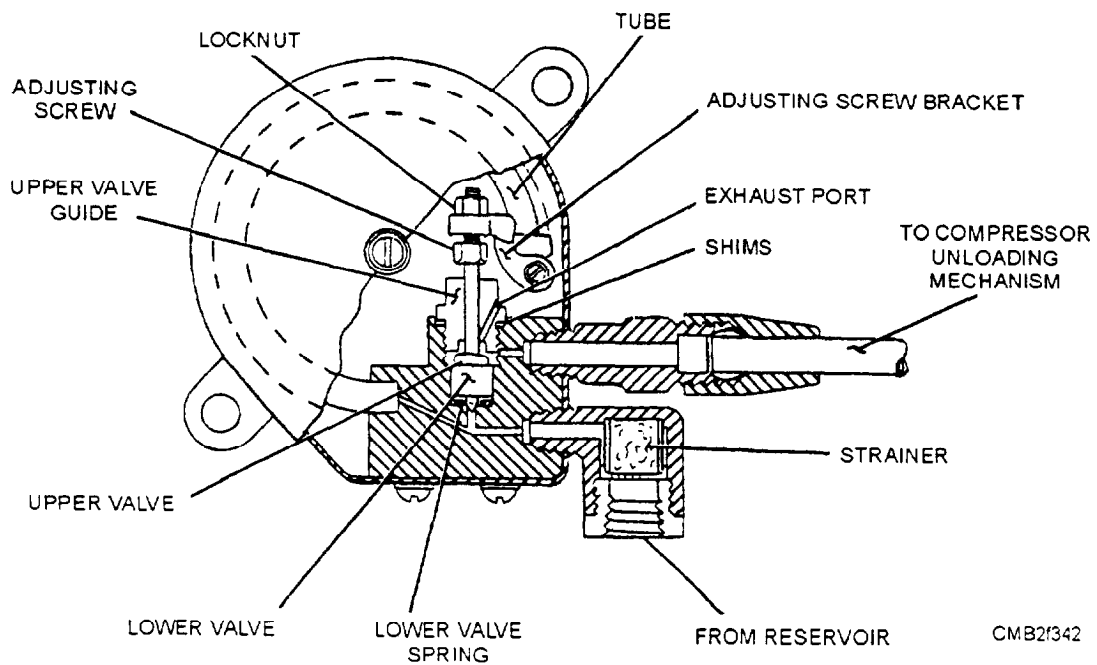

Figure 7-41.—Type O-1 governor.

valve and out the upper connection to the unloader assembly located in the compressor cylinder head. When the unloader valves open, the compression of air is stopped.

When reservoir pressure is reduced to the cut-in setting of the compressor governor (80 to 85 psi), the governor tube again exerts sufficient spring pressure on the valve mechanism to depress and close the lower valve and open the upper valve, thereby shutting off and exhausting the air from the compressor unloading mechanism and compression is resumed.

The pressure range and setting should be checked periodically using an air gauge known to be accurate. Pressure range may be changed in the type O-1 governor by adding shims beneath the upper valve guide to decrease the range, or removing shims to increase the range. Pressure settings may be changed, if necessary, by turning the adjusting screw to the left to increase the setting or to the right to decrease the setting.

The strainer should be removed periodically and cleaned. Check the governor periodically for excessive leakage in both the cut-in and cutout positions. If the governor fails to operate properly, it should be repaired or replaced.

In the type D governor (fig. 7-42) when the reservoir pressure reaches the cut-out setting (100 to 110 psi), the governor diaphragm is subjected to sufficient air pressure to overcome the spring loading.

This action allows the valve mechanism to move up, permitting the exhaust stem to close the exhaust valve and to open the inlet valve. Reservoir pressure then passes through the governor to operate the compressor unloading mechanism, stopping further compression of the air compressor.

When the reservoir pressure is reduced to the cut-in setting (80 to 85 psi), the spring loading within the governor overcomes the air pressure under the diaphragm. The valve mechanism is actuated, closing the inlet valve and opening the exhaust valve, thereby shutting off and exhausting the air from the compressor unloading mechanism and compression is resumed.

Pressure range and setting should be checked periodically, using an accurate air gauge. The pressure range (pressure differential) between loading and unloading of the type D governor is a function of the design of the unit and should not be changed. The designed range for this governor is approximately 20 percent of the cutout pressure setting. The pressure settings of the type D governor may be adjusted by turning the adjusting nut clockwise to increase or counterclockwise to decrease the settings.

Both strainers should be removed periodically and cleaned or replaced. The governor should periodically be checked for leakage at the exhaust port in both the cut-in and cutout positions. If the governor fails to operate properly, it should be repaired or replaced.

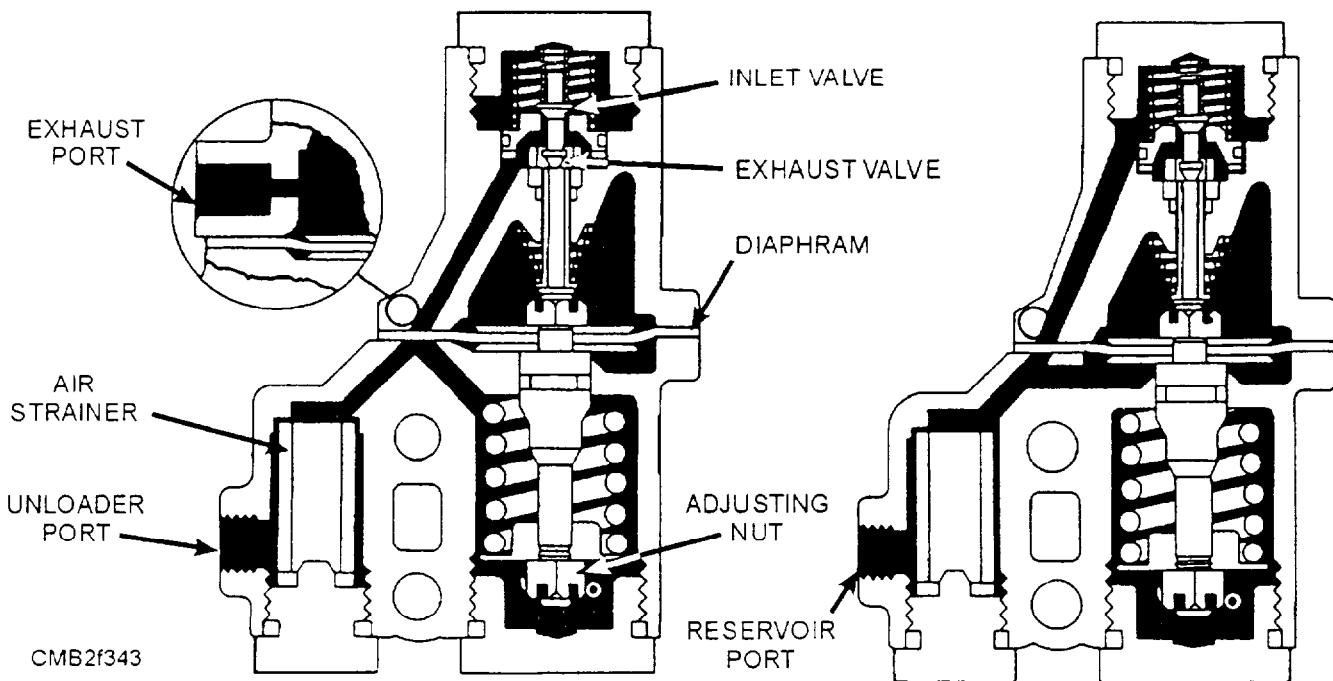

Figure 7-42.—Type D governor.



The UNLOADER assembly (fig. 7-43) is mounted in the compressor head and controlled by the governor. The unloader valve may be either a poppet-type or a spring-loaded control valve. Air pressure from the governor opens the unloader valves to unload or stop compression in the compressor.

When the reservoir air pressure reaches the maximum setting of the governor, air under pressure is allowed by the governor to pass into a cavity below an unloading diaphragm. This air pressure lifts one end of the unloading lever, which pivots on its pin and forces the unloading valves off their seats. With the unloading valves off their seats, the unloading cavity forms a passage between the cylinders above the pistons. Air then passes back and forth through the

cavity between the cylinders and compression is stopped. A drop in air pressure below the minimum setting of the governor causes it to release the air pressure from beneath the unloading diaphragm, allowing the unloading valves to return to their seats resuming compression.

### AIR TANKS (RESERVOIRS)

The two steel air tanks, commonly known as reservoirs, are used to cool, store, remove moisture from the air, and give a smooth flow of air to the brake system.

At the bottom of each tank is a drain valve (fig. 7-44). This valve is used to allow the operator a means to drain the air from the tanks daily, thereby preventing

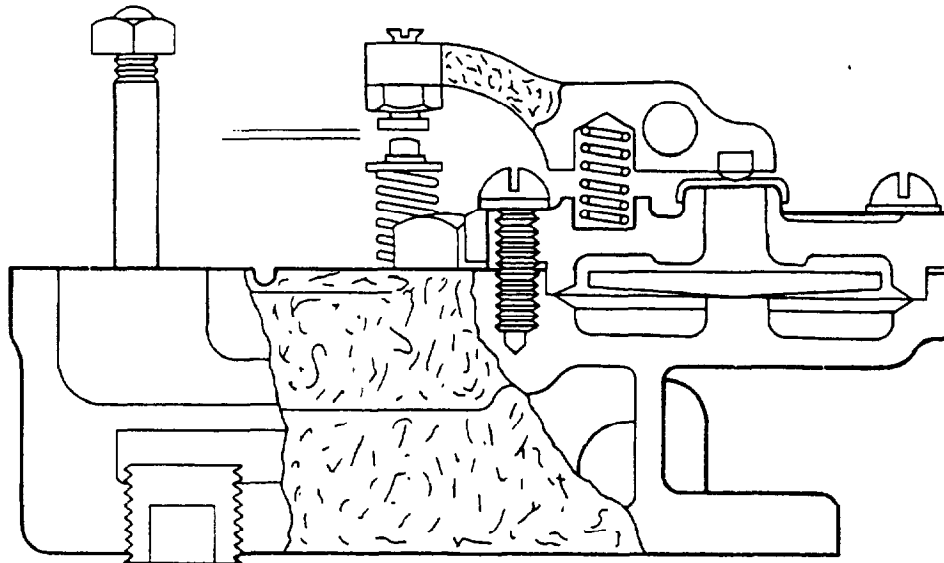
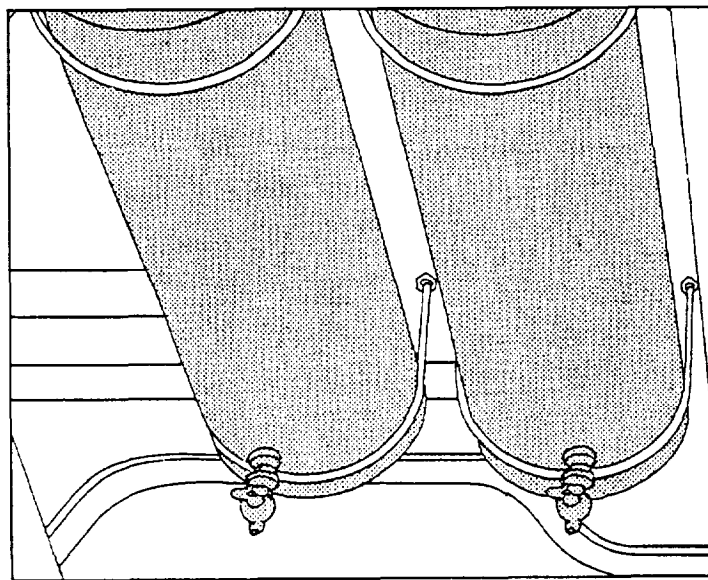

Figure 7-43.—Unloader assembly.



CMB27345

Figure 7-44.—Air reservoir with an air drain valve.

any moisture buildup in the system. Moisture in the system prevents the brakes from actuating smoothly.

A safety valve is located on top of the first reservoir and consists of an adjustable spring-loaded bail-check valve in a body. It is used to protect the system against excessive pressures, normally set at approximately 150 psi.

### BRAKE CHAMBERS

The brake chamber (fig. 7-45) converts the energy of the compressed air into mechanical force to operate the brakes. When the brake pedal is actuated, air under pressure enters the brake chamber behind the diaphragm and forces the pushrod out against the return spring force. Because the yoke on the end of the pushrod is connected to the slack adjuster, this movement rotates the slack adjuster, brake camshaft, and cam to apply the brakes.

When the pedal is released, air is forced from the brake chamber by the brake shoe return spring acting on the linkage. After the shoes reach the fully released position, the return springs acting on the diaphragm causes it to return to its original position in the chamber.

When performing maintenance of the brake system, check the brake chamber alignment to avoid binding action. Check the pushrod travel periodically, and when necessary, adjust the brakes so that pushrod travel is as short as possible without the brakes dragging. The pushrod length should be adjusted so that the angle between the center line of the slack adjuster and the brake chamber pushrod is 90 degrees when the pushrod is extended to the center of its working stroke.

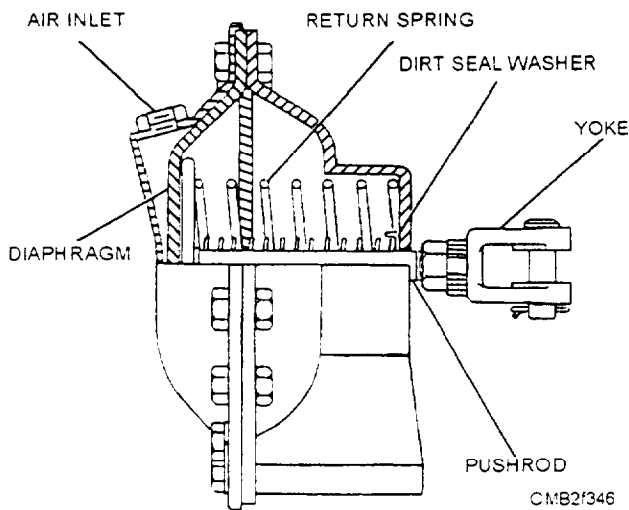

Figure 7-45.—Brake chamber.

Replace the diaphragm if it is worn or leaking. Replace the boot if it is worn or cracked. With the brakes applied, cover the edges of the diaphragm and bolt with soapy water to detect leakage. If leaks are present, tighten the bolts uniformly until the leaks stop. Bolts should not be tightened so that the diaphragm shows signs of bulging or distortion.

### SLACK ADJUSTERS

The slack adjusters (fig. 7-46) function as adjustable levers and provide a means of adjusting the brakes to compensate for wear of linings. Air pressure, admitted to the brake chamber when the brake pedal is depressed, moves the slack adjuster toward the position indicated by the dotted lines.

The entire slack adjuster rotates as a lever with the brake camshaft, as the brakes are applied or released. Turning the adjusting screw makes the brake adjustments necessary to maintain proper slack adjuster arm travel (shoe and drum clearance). This action rotates the worm gear, camshaft, and cam, expanding the brake shoes so that the slack caused by brake lining wear is eliminated and the slack adjuster arm travel is returned to the correct setting. The movement of the cam forces the brake shoes against the brake drum. Friction of the brake lining against the drum stops the turning movement of the wheel. When the brakes are released, the brake shoe return spring pulls the shoes back to a DISENGAGED position.

### BRAKE VALVES

There are numerous brake valves used in an air brake system. These valves either apply or release air

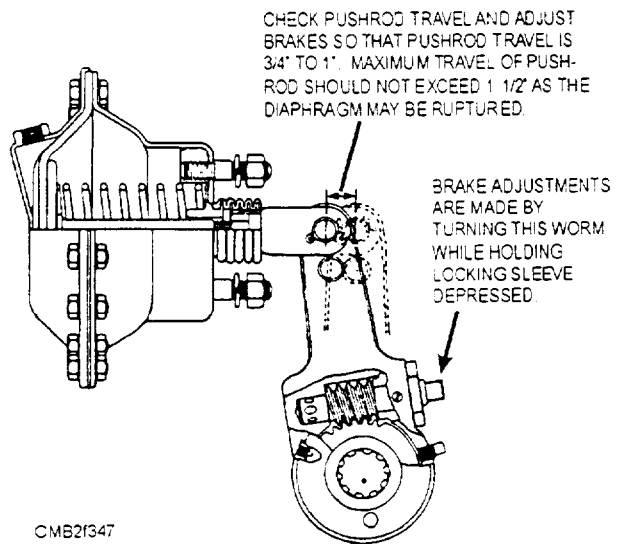

Figure 7-46.—Slack adjuster.

from the brakes and work together to ensure control and safe braking application. These valves are as follow:

- Treadle valve (brake valve)
- Trailer control valve (brake valve)
- Quick-release valve
- Combined-limiting and quick-release valve
- Tractor protection valve
- Relay emergency valve
- Check valves

In the following paragraphs we will discuss each valve in more detail.

### **Treadle Valve**

The treadle valve (fig. 7-47) controls the air pressure delivered to the brake chambers. When the treadle valve is depressed, force is transmitted to the pressure regulating spring and diaphragm that is

moved downward and contacts the exhaust valve and closes it. Continued movement opens the inlet valve and air pressure from the reservoir flows through the valve and into the delivery lines to apply the brakes. As the air pressure increases below the diaphragm, it overcomes the force above the diaphragm and the diaphragm raises slightly. This action allows the inlet valve to close but also keeps the exhaust valve closed, thereby obtaining a balanced position. Further depression of the treadle valve increases the forces above the diaphragm and correspondingly increases the delivered air pressure until a new balanced position is reached.

Maintenance of the treadle valve consists of periodic lubrication of the hinge and roller. Should the valve malfunction, it can be disassembled and cleaned. After cleaning, the internal parts should be lubricated with Vaseline before reassembly. This prevents moisture in the air system from causing corrosion and freezing of the valve. If cleaning does not remedy the malfunction, the valve must be replaced.

**Figure 7-47.—Treadle valve.**

## Trailer Control Valve

The independent trailer control valve (fig. 7-48) provides the operator with control of the trailing load at all times. This valve functions in the same manner as the treadle valve except that the handle is turned, rather than depressed, to operate the valve.

## Quick-Release Valve

The quick-release valve (fig. 7-49) exhausts brake chamber air pressure and speeds up brake release by reducing the distance the air would have to travel back to the brake valve exhaust port.

When the brakes are engaged, air from the brake valve enters into the quick-release valve, forcing the diaphragm down and closing off the exhaust port. This action allows air pressure to rush through the quick-release valve outlet ports to the wheel brake chambers. When the brakes are released, the air pressure above the quick-release diaphragm is

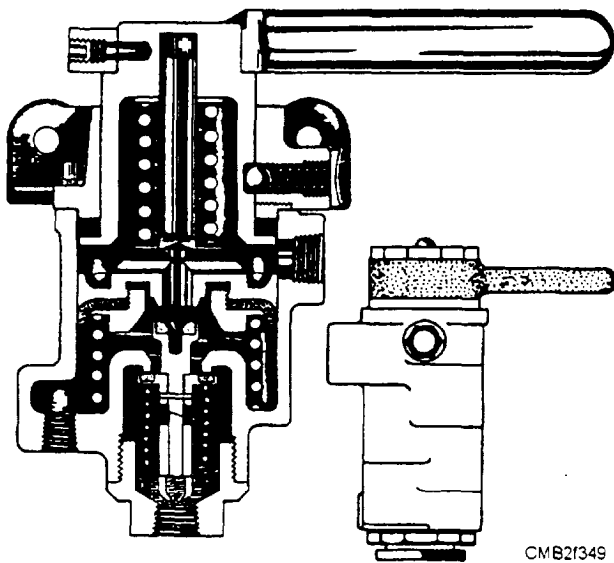

Figure 7-48.—Trailer control valve.

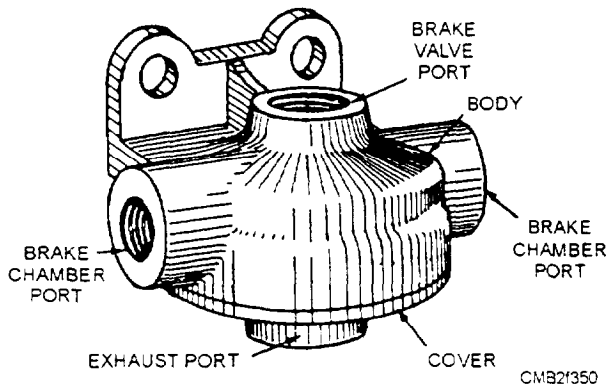

Figure 7-49.—Quick-release valve.

exhausted at the brake valve. As air pressure above the diaphragm is released, the air pressure below the diaphragm raises off the exhaust port. This action allows the air in the brake chambers to exhaust at the quick-release valve.

When air is leaking from the system, a leakage test can determine if there is air leaking at the quick-release valve. The leakage test is performed with the brakes applied and coating the exhaust port with soapsuds. If air bubbles form, this is a sign of a defective valve, which can be corrected by either cleaning and replacing worn parts or by replacing the unit. Dirt, worn diaphragm, or a worn seat causes leakage.

## Combined-Limiting and Quick-Release Valve

The combined-limiting and quick-release valve (fig. 7-50) is used in combination with a two-way check valve in the air brake system of trucks and tractors. The combined-limiting and quick-release valve is interchangeable in mounting with the quick-release valve and serves the same purpose with the additional function of providing an automatic reduction of front-wheel brake pressure, at the option of the operator, on slippery roads.

## Tractor Protection Valve

The primary purpose of the tractor protection valve (fig. 7-51) is to protect the tractor air brake system under trailer breakaway conditions and under conditions where severe leakage develops in the tractor or trailer.

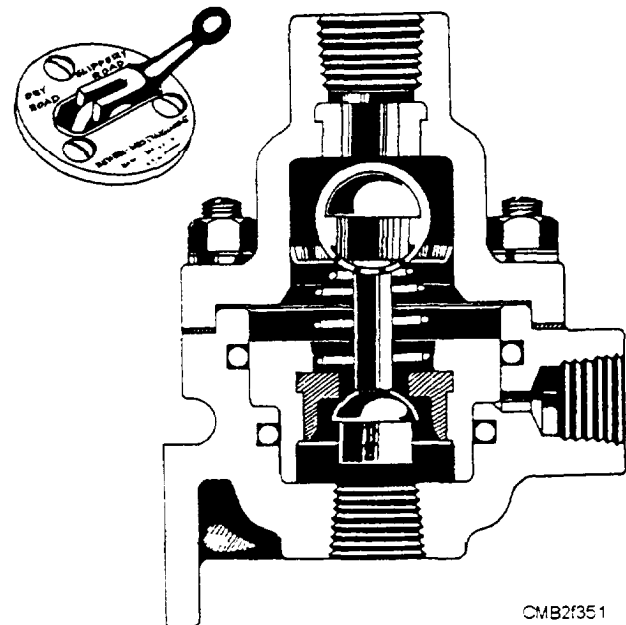

Figure 7-50.—Combined-limiting and quick-release valve.

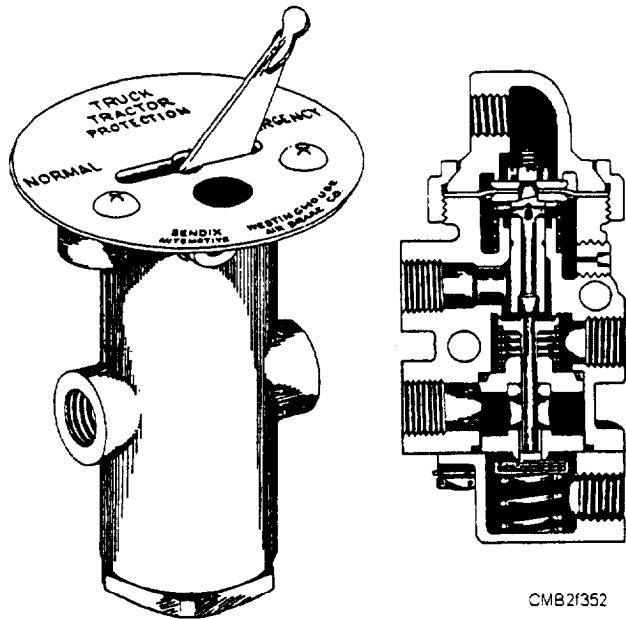

Figure 7-51.—Tractor protection valve and switch.

The tractor protection system functions as a set of remotely controlled cutout valves (fig. 7-52). The trailer service and emergency lines pass through the valve. When the control valve is in the NORMAL position, service and emergency braking functions of both the tractor and trailer are normal. When the valve lever is in the EMERGENCY position, the trailer air brakes lines are closed off.

Should a condition resulting in severe air loss from the tractor or trailer air brake system be detected or if for any other reason it is desirable to cause an emergency application of the trailer brakes, the operator can move the control valve lever to the EMERGENCY position. At this time both the trailer service and emergency brake line will be closed off at the tractor protection valve. Such operation offers a convenient daily check of the relay emergency valve on the trailer where tractors and trailers are not

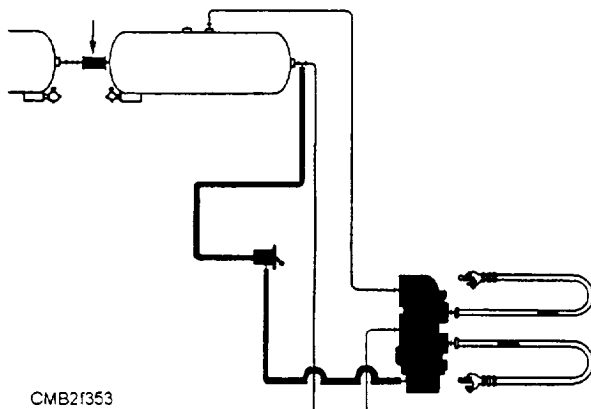

Figure 7-52.—Tractor protection valve piping.

disconnected over long periods of time. The operator should move the control to the EMERGENCY position when disconnecting a trailer or when operating a tractor without a trailer if cut-off valves are not installed in the trailer connections on the tractor. The tractor protection valve should NOT be used as a parking brake, because it was not designed for that purpose.

### Relay Emergency Valve

The relay emergency valve (fig. 7-53) acts as a relay station to speed up the application and release of trailer brakes. It automatically applies the trailer brakes when the emergency line of the trailer is broken, disconnected, or otherwise vented to the atmosphere if the trailer air brake system is charged. It is used on trailers that require an emergency brake application upon breakaway from the truck or tractor.

When a tractor is connected to a trailer and the service and emergency lines are opened, the relay emergency valve permits charging the trailer air brake reservoir to approximately the same air pressure as that in the tractor reservoirs. During normal operation of a tractor-trailer unit, the relay emergency valve functions as a relay valve and synchronizes trailer service brake air pressure and tractor service brake air pressure, as the treadle valve on the tractor is operated. The trailer brakes can also be applied independently of the tractor brakes by use of the hand control on the tractor protection valve on the tractor and the relay emergency valve on the trailer.

If a trailer is disconnected from a tractor for loading or unloading or if the trailer is separated from the tractor under emergency breakaway conditions or if the emergency line of the trailer is vented to the atmosphere by other means, the relay emergency valve applies the trailer brakes. This is automatically achieved by using the existing trailer reservoir air pressure. If the trailer is to remain parked under these conditions, the wheels should be blocked to prevent the possibility of a runaway.

If you are required to release the emergency brake application on a trailer under these conditions, the trailer reservoir drain valve can be opened or the trailer air brake system can be recharged through the trailer emergency line.

You can check the relay emergency valve by moving the tractor protection valve control lever to the EMERGENCY position, if tractor protection equipment is installed. If no tractor protection is

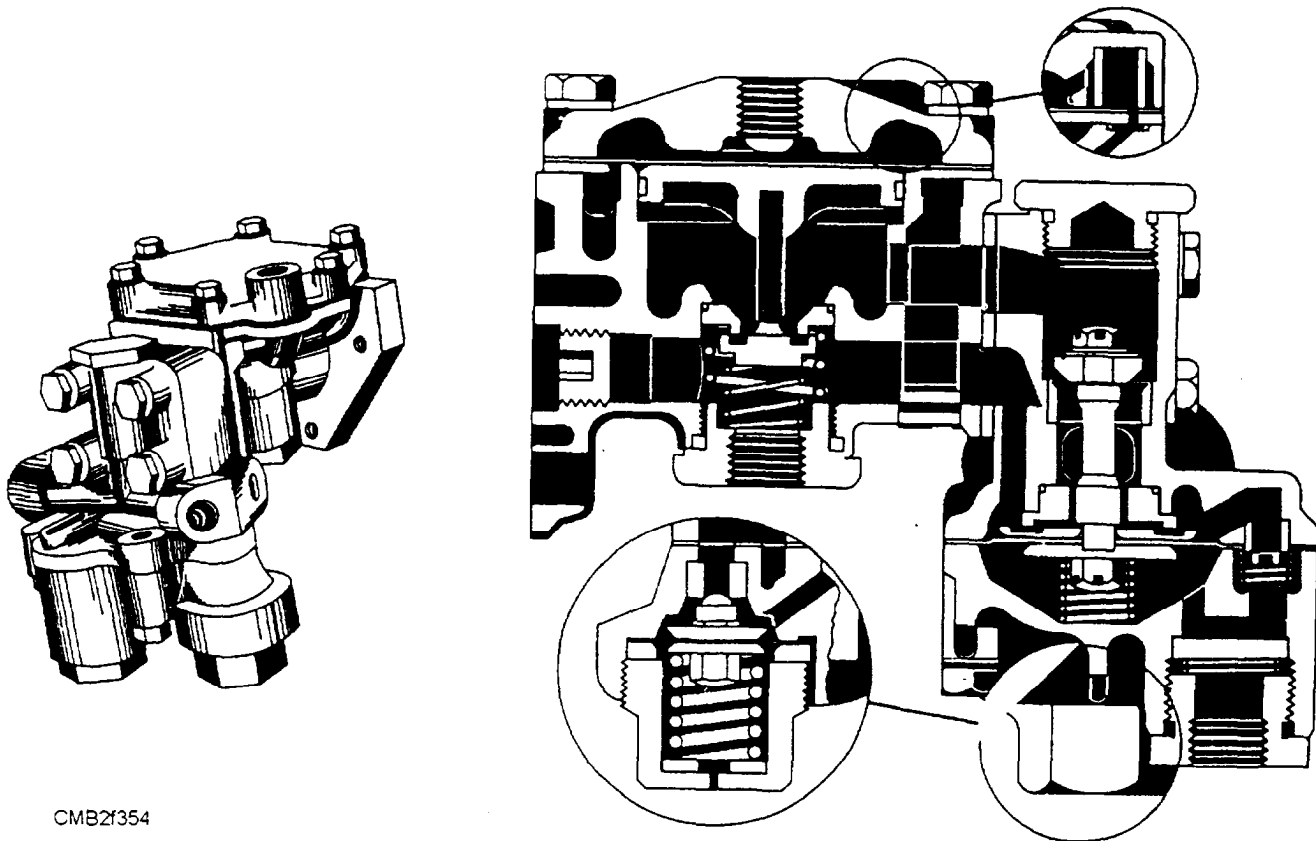

CMB2f354

Figure 7-53.—Relay emergency valve.

installed, by closing the emergency line cutout valve and uncoupling the emergency brake line, the valve can be checked. Either way the trailer brakes should apply automatically. Trailer brakes should release, in the first case, when the tractor protection valve control lever is moved to the NORMAL position, and, in the second case, when the emergency line is coupled and the cutout valve is opened.

The relay emergency valve is checked for leakage by application of soapsuds with the brakes released. Check the emergency air line coupling with soapsuds to determine leakage with the valve in emergency application position. Leakage may be caused by dirt or worn parts which may be corrected by cleaning and/or replacing the unit.

### Check Valves

Check valves are located in the lines of air brake systems to prevent the loss of air should the line

rupture while in operation. These are placed at the entrance of the main air tanks and prevent the loss of air should the inlet line from the compressor fail. The ball-type check valve (fig. 7-54) is typical of the type used on trailer braking systems. Check valves may be either disc or ball and double or single units. Regardless of their design, their function is the same.

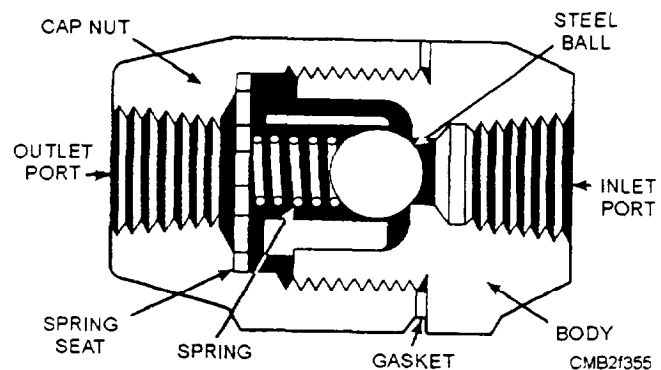

Figure 7-54.—Ball-type single check valve.

## AIR HOSES AND FITTINGS

Air hoses and fittings (fig. 7-55) provide a means of making a flexible air connection between points on a vehicle which change their position in relation to each other or between two vehicles. All air brake assemblies used to connect the air brake systems from one vehicle to another are equipped with detachable fittings and spring guards.

When installing a hose assembly where both ends are permanently connected, use the air hose connector assembly at each end as the union to permit tightening the hose connectors in place. Loosen the nut on one of the connector assemblies and then turn the hose in the loose connector to avoid kinking the hose.

To prevent dirt and moisture from entering unused air lines, use dummy couplings (fig. 7-56). The two types of dummy couplings are as follows:

- Bracket-type couplings are mounted to the vehicle for storage of unused hose.
- Chain-type couplings are attached to the vehicle by a chain and placed in couplings mounted on the vehicle.

## SYSTEM SWITCHES AND INDICATORS

The switches and indicators in an air brake system are designed as safety devices. The two most common safety devices found in an air brake system are the low-pressure warning indicator and the stoplight switch.

### Low-Pressure Warning Indicator

The low-pressure warning indicator (fig. 7-57) is an electro-pneumatic switch connected with a warning buzzer and, in some designs, a warning light or both. It remains in the OPEN position when air pressure is above approximately 60 psi. When pressure drops below 60 psi, the spring forces the diaphragm down and closes the contacts, which operate the warning

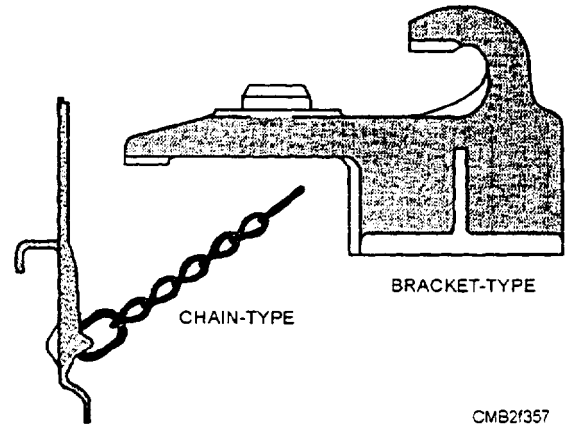

Figure 7-56.—Dummy couplings.

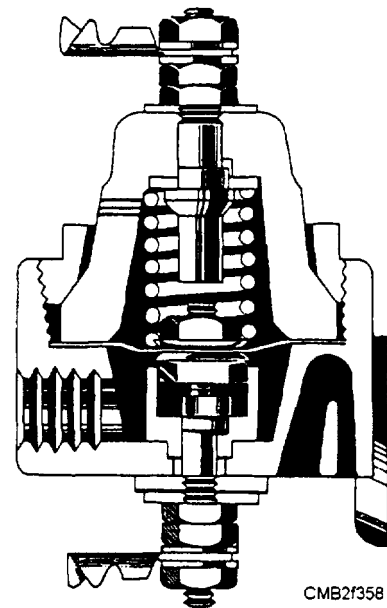

Figure 7-57.—Low-pressure warning indicator.

device. Normal operating pressure is 60 psi, plus or minus 6 pounds.

### Stoplight Switches

Stoplight switches (fig. 7-58) in an air brake system are electro-pneumatic devices, which operate in conjunction with the treadle valve to close the

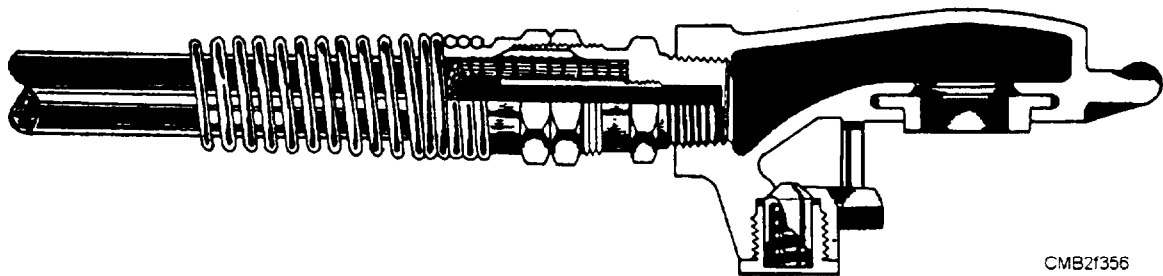

Figure 7-55.—Air hose and fittings.

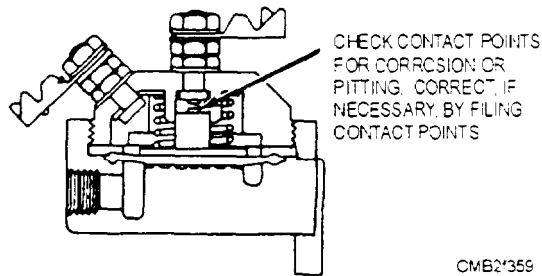

Figure 7-58.—Stoplight switch.

stoplight circuit when the brakes are applied. When air pressure from the treadle valve enters the cavity on the one side of the diaphragm, the diaphragm changes position. This action overcomes the force of the spring and moves the contact plunger until the contacts close. This closes the stoplight electrical circuit causing the brake lights to come on. The switch is designed to close as soon as 5 psi is delivered to it. This means that the stoplight circuit closes immediately on brake application.

## SERVICING AIR BRAKES

Servicing is the most important part of air brake maintenance. If the air brake system is kept clean, tight, and moisture-free, brake failures will be few and far between. Particular care must be taken to keep the air compressor intake filters clean and foreign material out of the lines.

The basic test made to an air brake system is the operational test. This test may be performed on the road or in the shop. During an operational test, the brakes are applied and released while observing for equal application, sluggish engagement or release, binding linkage, and exhaust of units.

To check the leakage of the overall system, fully charge the system, shut off the ignition, and observe the pressure drop on the gauge mounted on the vehicle dash. The maximum leakage will be expressed in pounds per a specific time.

### NOTE

Before making any leakage or pressure test, consult the manufacturer's specifications for correct pressure and maximum leakage.

To determine if leakage of various components is within permissible or authorized limits, use the soapsuds test. To make this test, use a thick mixture of soapsuds: do not use lye soap. This mixture is applied to places in the system where leakage may occur.

While some places are authorized some amount of leakage, others are not. For example, castings and the tube in the governor should have no leakage. Points with authorized leakage will have a specified maximum in pounds per a specified time.

Soapsuds can also be used to check the internal condition of a component. By covering exhaust ports or casting openings, you can check the condition of the diaphragms and valves. For example, to check the condition of the treadle valve, release the brakes and cover the exhaust ports with soapsuds. Engage the brakes: any leakage indicates the valve is not sealing properly. If the diaphragm in the brake chamber is faulty, leakage will appear around the pushrod with the brakes applied.

As with the drum brake system the linings used with air brakes gradually wear from use and require periodic adjustment or replacement. Always consult the manufacturer's specifications before making any adjustments to the air brake system. This is to ensure that the correct adjustment is made and that any variations in procedure are followed.

## REVIEW 2 QUESTIONS

- Q1. What are the three common methods for driving the air compressor from the engine?
- Q2. What is the purpose of the governor in an air brake system?
- Q3. What component controls the compressor unloading mechanism?
- Q4. On a type O-1 air compressor the pressure range may be adjusted by adding or removing shims from what location?
- Q5. What valve controls the air pressure delivered to the brake chambers?
- Q6. What is the function of the relay emergency valve?
- Q7. What component is used to prevent dirt and moisture entering unused air lines?

## AIR-OVER-HYDRAULIC BRAKE SYSTEM

**Learning Objective:** Describe the operation, terms, and component functions of an air-over-hydraulic brake system.



The air-over-hydraulic brake system is shown in figure 7-59. This system combines the use of compressed air and hydraulic pressure for brake application. Air pressure is supplied by a compressor and stored in reservoirs as with the air brake system. The master cylinder, wheel cylinders, and brake construction are very similar to that used in a hydraulic brake system. The essential difference between the straight hydraulic brake system and the air-over-hydraulic system lies in the AIR-HYDRAULIC-POWER CYLINDER.

### AIR-HYDRAULIC-POWER CYLINDER (AIR PAK)

The air-hydraulic-power cylinder (fig. 7-60) is a self-contained power brake unit. The three essential components of the air-hydraulic-power cylinder are as follows:

- The COMPRESSED AIR CYLINDER consists of a large diameter air piston operating within a cylinder body. This piston actuates a pushrod, which is attached to the hydraulic piston within the slave cylinder.

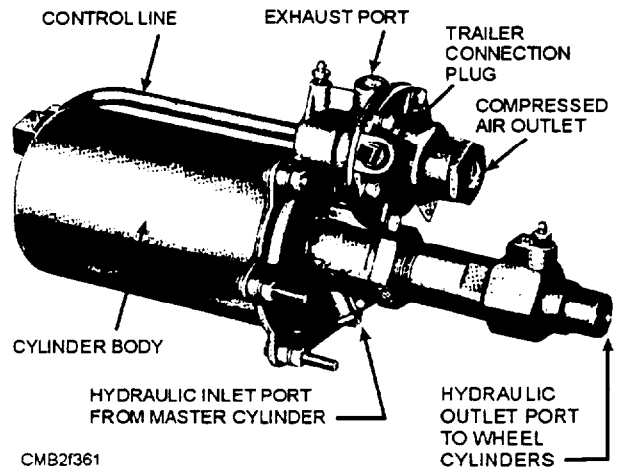

Figure 7-60.—Air-hydraulic power cylinder assembly (Air-Pak).

Movement of the piston in the compressed air cylinder is controlled by the amount of air, under pressure, that is allowed to enter through the control valve. The compressed air cylinder body is attached to the end plate on which the slave cylinder and control valve is

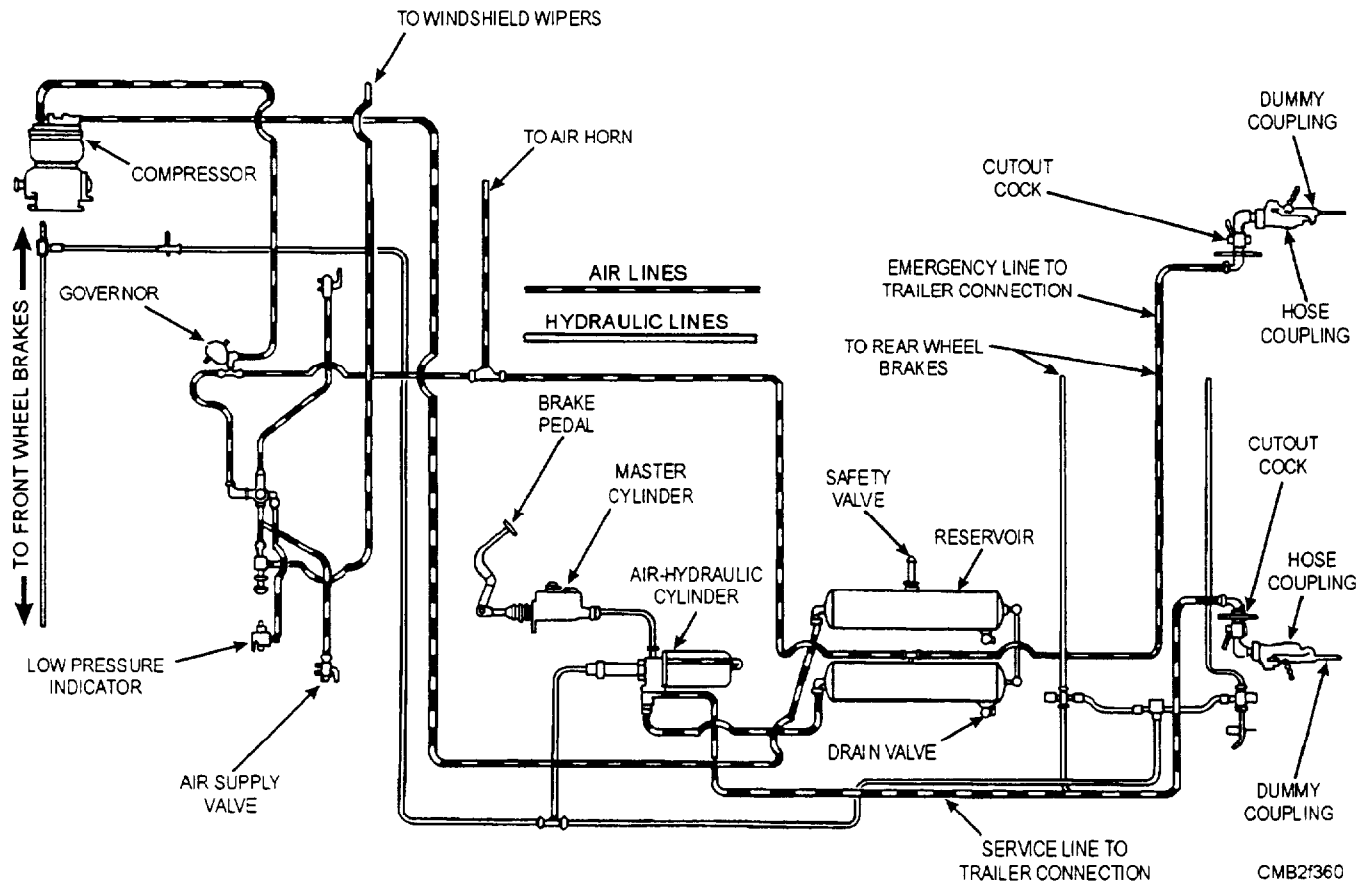

Figure 7-59.—Air-over-hydraulic brake system.

mounted. A return spring forces the power piston to the released position when the brake pedal is released.

- The **SLAVE CYLINDER** consists of a cylindrical housing in which a small diameter hydraulic piston operates. The outlet cap houses a residual check valve and a ball-check valve is located in the hydraulic piston.

- The **CONTROL VALVE** consists of two poppets operating within a housing and actuated by a hydraulic relay piston and a reactionary-type diaphragm. An air control line connects the control valve to the compressed air cylinder.

### **AIR-OVER-HYDRAULIC BRAKE OPERATION**

The air-over-hydraulic cylinder consists of an air cylinder and hydraulic cylinder in tandem, each fitted with a piston with a common piston rod between. The air piston is of greater diameter than the hydraulic piston. This difference in areas of the two pistons gives a resultant hydraulic pressure much greater than the air pressure admitted to the air cylinder. Automatic valves, actuated by fluid pressure from the master cylinder, control the air admitted to the air cylinder. Thus fluid pressure in the brake lines is always in direct ratio to foot pressure on the brake pedal.

Figure 7-61 shows the air-hydraulic power cylinder in the released position. Views A and B show the position of the valves and slave cylinder during light and heavy brake pedal application.

When the brakes are applied, as shown in view A of figure 7-61, pressure is transmitted by the brake fluid to the hydraulic piston in the slave cylinder and

the relay piston in the control valve. As hydraulic pressure builds, the relay piston moves the control valve diaphragm forward, closing the atmospheric poppet and slightly opening the air pressure poppet. Air under pressure then passes through the air control line forcing the power piston in the air cylinder forward until the air pressure on the diaphragm, in combination with spring pressure, allows the air poppet to close. The degree of brake application is determined by the amount of compressed air trapped in the power cylinder when brake pedal movement is stopped. Unless more pressure is applied or the brake pedal is released, the brakes will remain in the partially applied position.

View B of figure 7-61 shows the effect of applying high brake pedal pressure. Under this condition, the air pressure poppet is held open, allowing a full volume of compressed air to enter the air cylinder and cause full brake application.

As in a conventional hydraulic brake system the residual check valve maintains a small amount of pressure in the hydraulic system when the brakes are released. This prevents the cups in the wheel cylinders from collapsing and leaking.

### **REVIEW 3 QUESTIONS**

- Q1. What are the three essential components of an air-hydraulic-power cylinder?*
- Q2. In what component of the air-hydraulic-power cylinder is the residual check valve located?*
- Q3. What action actuates the automatic valves that control the air pressure admitted to the air cylinder?*

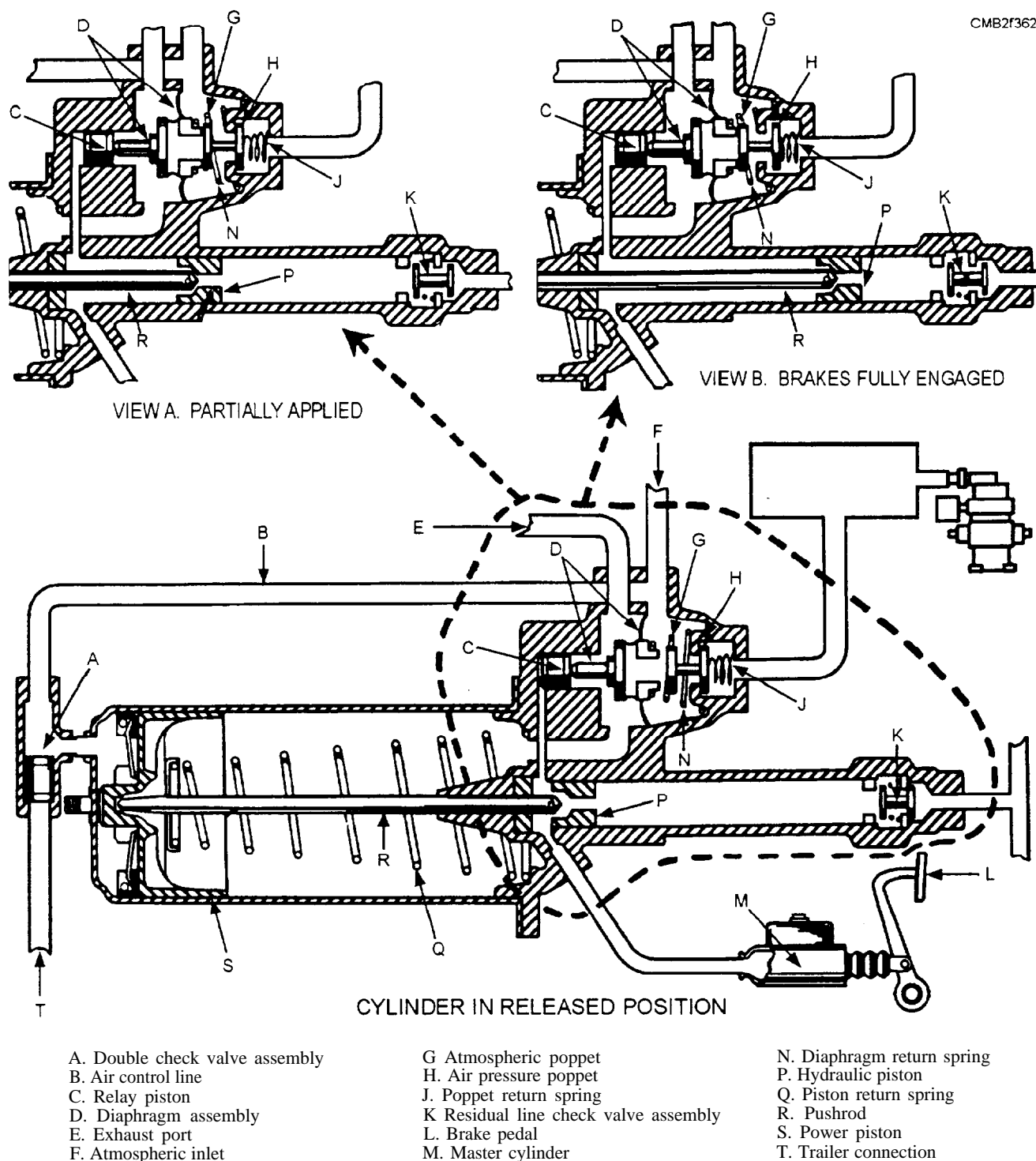

Figure 7-61.—Air-hydraulic power cylinder (Air-Pak) during operation.

## REVIEW 1 ANSWERS

- Q1. Operator reaction time*
- Q2. Braking ratio*
- Q3. 30 to 40 percent*
- Q4. Master cylinder*
- Q5. Diagonally split*
- Q6. Junction block*
- Q7. Cable type*
- Q8. False*
- Q9. Nonmetallic, semimetallic, and metallic*
- Q10. Caliper*
- Q11. Equalizes braking action at each wheel during light brake applications*
- Q12. A valve combining several valve junctions into a single assembly*
- Q13. ABS computer*
- Q14. Trigger wheels*
- Q15. True*
- Q16. Brake pedal free play, brake pedal height, and brake pedal reserve distance*
- Q17. 1/8 inch*
- Q18. Bench bleed the master cylinder*
- Q19. Brake drum micrometer*
- Q20. Brake disc runout*
- Q21. Only enough to true the disc*
- Q22. 10 to 15 psi*

## REVIEW 2 ANSWERS

- Q1. Gear, belt, and chain*
- Q2. To maintain the air pressure in the reservoirs between maximum and minimum pressure automatically*
- Q3. Governor*
- Q4. Beneath the upper valve guide*
- Q5. Treadle valve*
- Q6. Acts as a relay station to speed up the release and application of trailer brakes*
- Q7. Dummy couplings*

## REVIEW 3 ANSWERS

- Q1. Compressed air cylinder, slave cylinder, and control valve*
- Q2. Slave cylinder*
- Q3. Fluid pressure from the master cylinders off*

## CHAPTER 8

# AUTOMOTIVE CHASSIS AND BODY

### INTRODUCTION

**Learning Objective:** Identify the types of automotive suspension and steering systems, their components, their functions, and maintenance requirements. State the characteristics and basic construction of a tire. Describe the procedures for maintaining tires, wheels, and wheel bearings. State the purpose of each wheel alignment setting. Describe the different types of equipment used during wheel alignment service. Describe the procedures for repairing and refinishing automotive bodies.

The automotive chassis provides the strength necessary to support the vehicular components and the payload placed upon it. The suspension system contains the springs, the shock absorbers, and other components that allow the vehicle to pass over uneven terrain without an excessive amount of shock reaching the passengers or cargo. The steering mechanism is an integral portion of the chassis, as it provides the operator with a means of controlling the direction of travel. The tires grip the road surface to provide good traction that enables the vehicle to accelerate, brake, and make turns without skidding. Working in conjunction with the suspension, the tires absorb most of the shocks caused by road irregularities. The body of the vehicle encloses the mechanical components and

passenger compartment. It is made of relatively light sheet metal or composite plastics. The components which make up the chassis are held together in proper relation to each other by the frame.

### FRAMES

**Learning Objective:** Describe the function, construction, and types of frames used on wheeled vehicles.

The separate frame and body type of vehicle construction (fig. 8-1) is the most common technique used when producing most full-sized and cargo vehicles. In this type of construction, the frame and the vehicle body are made separately, and each is a complete unit by itself. The frame is designed to support the weight of the body and absorb all of the loads imposed by the terrain, suspension system, engine, drive train, and steering system, and the body merely contains and, in some cases, protects the cargo. The body generally is bolted to the frame at a few points to allow for flexure of the frame and to distribute the loads to the intended load-carrying members. The components of this type of frame are as follows (fig. 8-2):

- The **SIDE MEMBERS** or rails are the heaviest part of the frame. The side members are shaped to

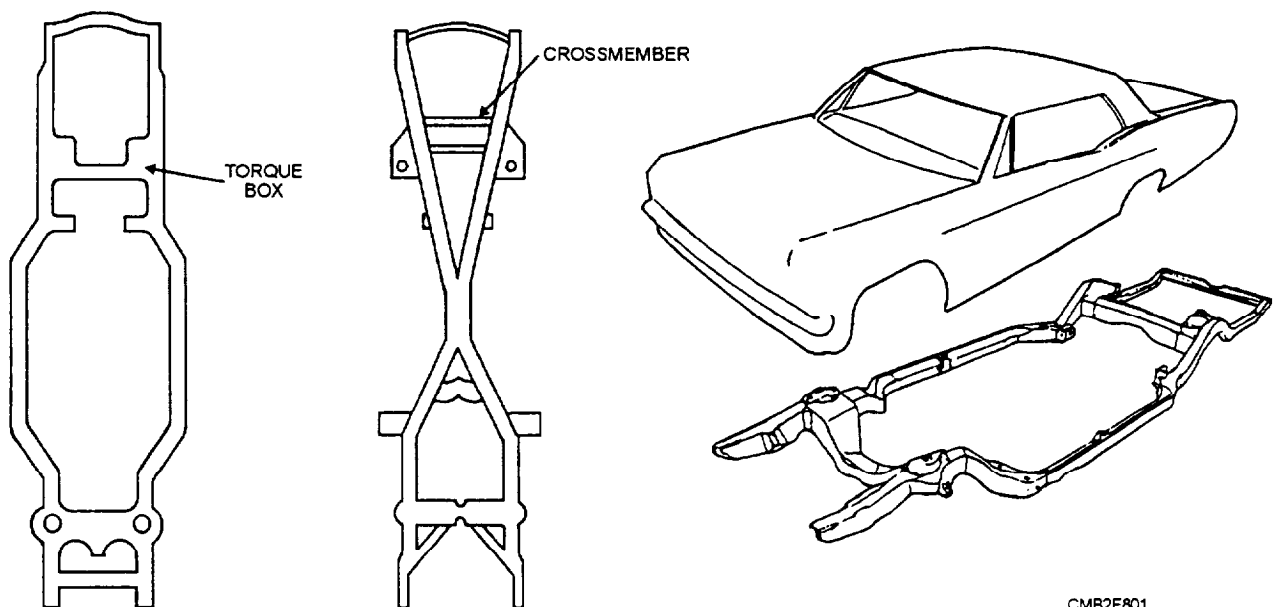
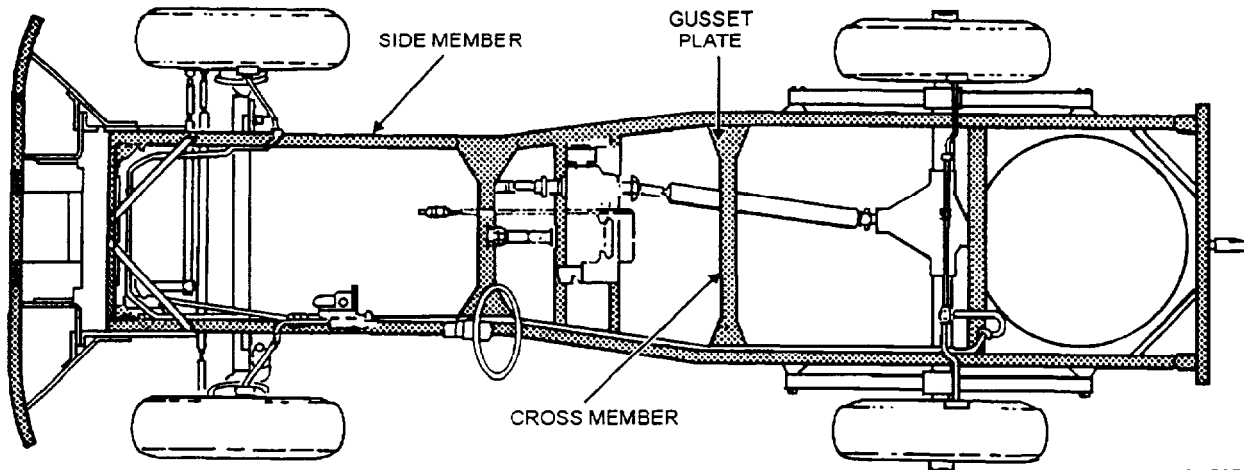

Figure 8-1.—Separate frame and body.

CMB2F801



CMB2F802

Figure 8-2.—Components of a typical frame design.

accommodate the body and support the weight. They are narrow toward the front of the vehicle to permit a shorter turning radius for the wheels and then widen under the main part of the body where the body is secured to the frame. Trucks and trailers commonly have frames with straight side members to accommodate several designs of bodies and to give the vehicle added strength to withstand heavier loads.

- The CROSS MEMBERS are fixed to the side members to prevent weaving and twisting of the frame. The number, size, and arrangement of the cross members depend on the type of vehicle for which the frame was designed. Usually, a front cross member supports the radiator and the front of the engine. The rear cross members furnish support for the fuel tanks and rear trunk on passenger cars and the tow bar connections for trucks. Additional cross members are added to the frame to support the rear of the engine or power train components.

- The GUSSET PLATES are angular pieces of metal used for additional reinforcement on heavy-duty truck frames.

With this type of frame construction, the body structure only needs to be strong and rigid enough to contain the weight of the cargo and resist any dynamic loads associated with cargo handling and cargo movement during vehicle operation and to absorb shocks and vibrations transferred from the frame. In some cases, particularly under severe operating conditions, the body structure may be subjected to some torsional loads that are not absorbed completely by the frame. This basically applies to heavy truck and not passenger vehicles. In a typical passenger vehicle, the frame supplies approximately 37 percent of the torsional rigidity and approximately 34 percent of the

bending rigidity; the balance is supplied by the body structure. The most important advantages of the separate body and frame construction are as follows:

- Ease of mounting and dismounting the body structure.
- Versatility; various body types can be adapted to a standard truck chassis.
- Strong, rugged designs are achieved easily; however, vehicle weight is increased.
- Isolation of noise generated by drive train components from the passenger compartment through the use of rubber mounts between the frame and the body.
- Simplistic design that yields a relatively inexpensive and easy manufacturing process.

Frame members serve as supports to which springs, independent suspensions, radiators, or transmissions may be attached. Additional brackets, outriggers, and engine supports are added for the mounting of running boards, longitudinal springs, bumpers, engines, towing blocks, shock absorbers, gas tanks, and spare tires.

### INTEGRATED FRAME AND BODY (MONOCOQUE)

The integrated frame and body type of construction (fig. 8-3) also referred to as unitized construction, combines the frame and body into a single, one-piece structure. This is done by welding the components together, by forming or casting the entire structure as one piece, or by a combination of these techniques. Simply by welding a body to a conventional frame, however, does not constitute an

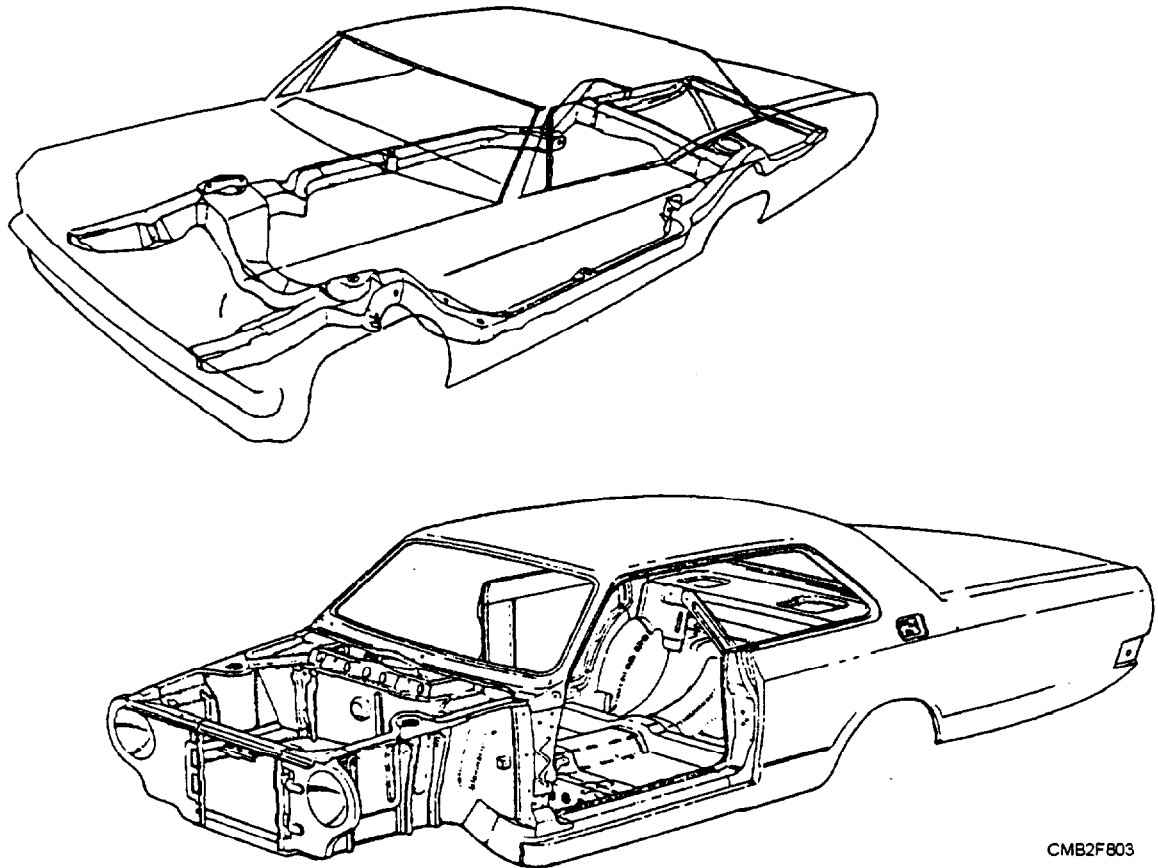

CMB2F803

Figure 8-3.—Integrated frame and body.

integral frame and body construction. In a truly integrated structure, the entire frame-body unit is treated as a load-carrying member that reacts to all loads experienced by the vehicle—road loads as well as cargo loads.

Integrated-type bodies for wheeled vehicles are fabricated by welding preformed metal panels together. The panels are preformed in various load-bearing shapes that are located and oriented so as to result in a uniformly stressed structure. Some portions of the integrated structure resemble framelike components, while other resembles bodylike panels. This is not surprising, because the structure must perform the functions of both of these elements.

An integrated frame and body type construction allows an increase in the amount of noise transmitted into the passenger compartment of the vehicle. However, this disadvantage is negated by the following advantages:

- Substantial weight reduction, which is possible when using a well-designed unitized body
- Lower cargo floor and vehicle height

- Protection from mud and water required for drive line components on amphibious vehicles
- Reduction in the amount of vibration present in the vehicle structure

### TRUCK FRAME (LADDER)

The truck frame (fig. 8-4) allows for different types of truck beds or enclosures to be attached to the frame. For larger trucks, the frames are simple, rugged, and of channel iron construction. The side rails are parallel to each other at standardized widths to permit the mounting of stock transmissions, transfer cases, rear axles, and other similar components. Trucks that are to be used as prime movers have an additional reinforcement of the side rails and rear cross members to compensate for the added towing stresses.

### FRAME MAINTENANCE

Frames require little, if any, maintenance. However, if the frame is bent enough to cause misalignment of the vehicle or cause faulty steering, the vehicle should be removed from service. Drilling the frame and fishplating can temporarily repair small

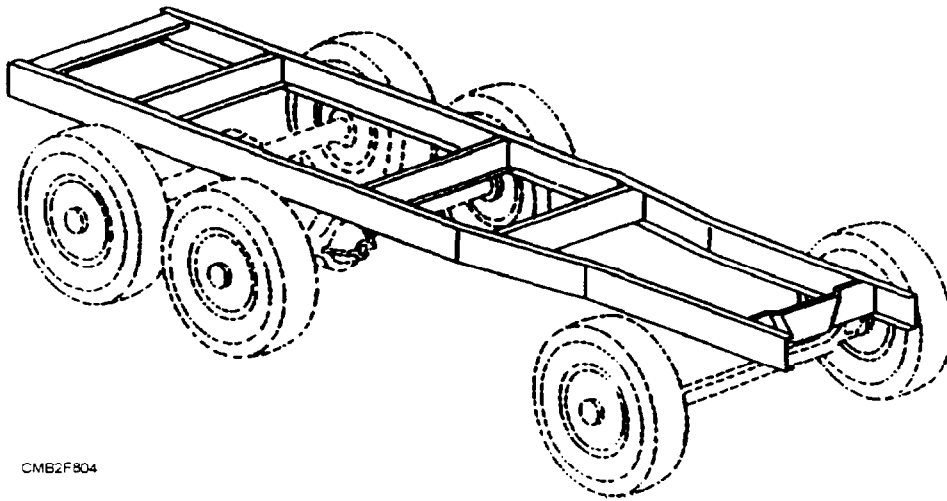

CMB2F804

Figure 8-4.—Truck frame (Ladder).

cracks in the frame side rails. Care should be exercised when performing this task, as the frame can be weakened. The frame of the vehicle should not be welded by gas or arc welding unless specified by the manufacturer. The heat removes temper from the metal, and, if cooled too quickly, causes the metal to crystallize. Minor bends can be removed by the use of hydraulic jacks, bars, and clamps.

### REVIEW 1 QUESTIONS

- Q1. What component of the frame prevents the side members from weaving and twisting the frame?
- Q2. The integrated frame and body type of construction is also known by what term?
- Q3. One advantage of an integrated frame and body is that the amount of noise transmitted into the passenger compartment is decreased. (T/F)

### SUSPENSION SYSTEMS

**Learning Objective:** Identify automotive suspension components, their functions, and maintenance requirements.

The suspension system works with the tires, frame or unitized body, wheels, wheel bearings, brake system, and steering system. All of the components of these systems work together to provide a safe and comfortable means of transportation. The suspension system functions are as follows:

- Support the weight of the frame, body, engine, transmission, drive train, passengers, and cargo.

- Provide a smooth, comfortable ride by allowing the wheels and tires to move up and down with minimum movement of the vehicle.
- Work with the steering system to help keep the wheels in correct alignment.
- Keep the tires in firm contact with the road, *even* after striking bumps or holes in the road.
- Allow rapid cornering without extreme body roll (vehicle leans to one side).
- Allow the front wheels to turn from side to side for steering.
- Prevent excessive body squat (body tilts down in rear) when accelerating or with heavy loads.
- Prevent excessive body dive (body tilts down in the front) when braking.

The suspension systems are grouped into two categories, which are as follows:

- **NONINDEPENDENT SUSPENSION (Solid Axle)** (fig. 8-5)—The nonindependent suspension has both left and right wheels attached to the same solid axle. When one tire hits a bump in the road, its upward movement causes a slight tilt in the other wheel. With a solid axle setup, the steering knuckle and wheel spindle assemblies are connected to the axle beam by bronze-bushed kingpins, or spindle bolts, which provide pivot points for each wheel.

- **INDEPENDENT SUSPENSION** (fig. 8-6)—The independent suspension allows one wheel to move up and down with a minimum effect on the other wheels. Since each wheel is attached to its own suspension unit, movement of one wheel does NOT cause direct movement of the wheel on the opposite side of the



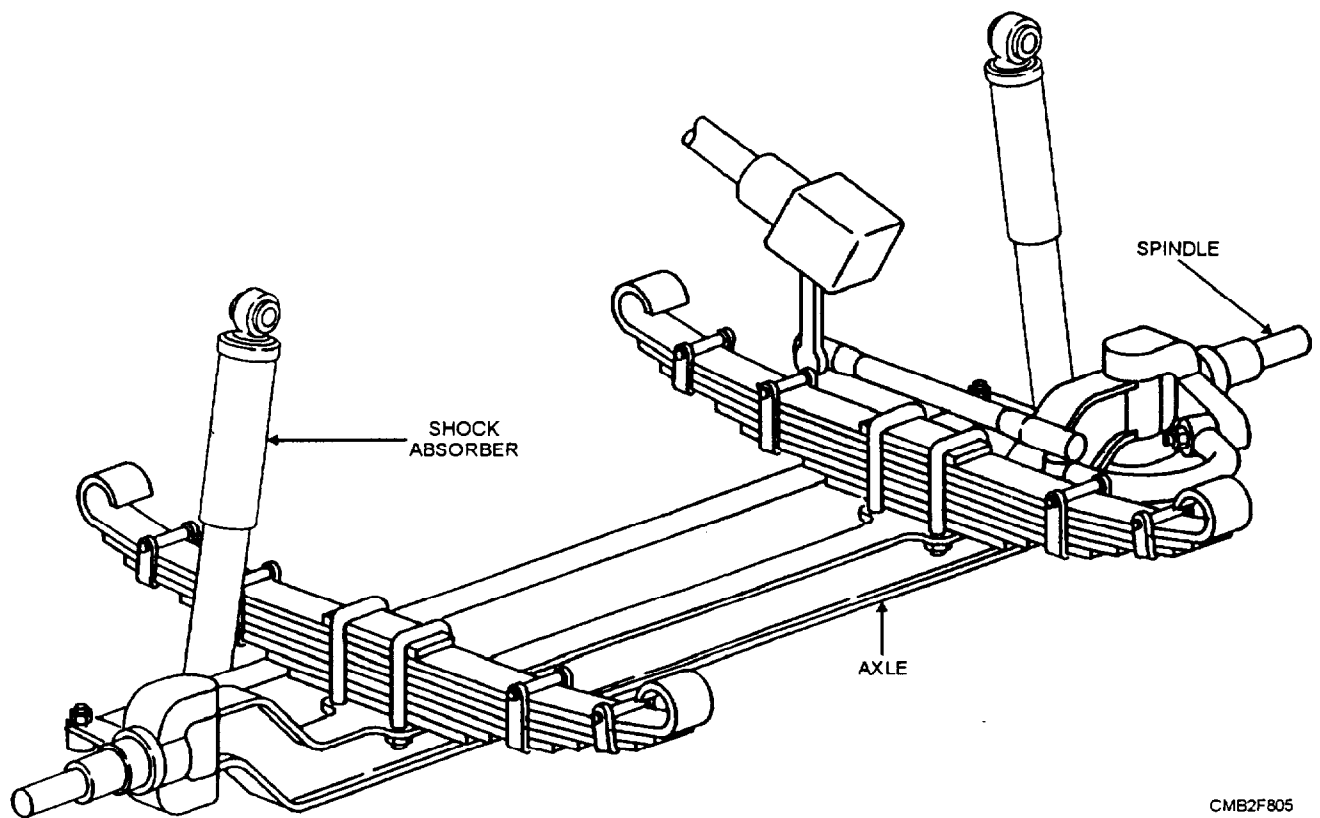

CMB2F805

Figure 8-5.—Nonindependent suspension system.

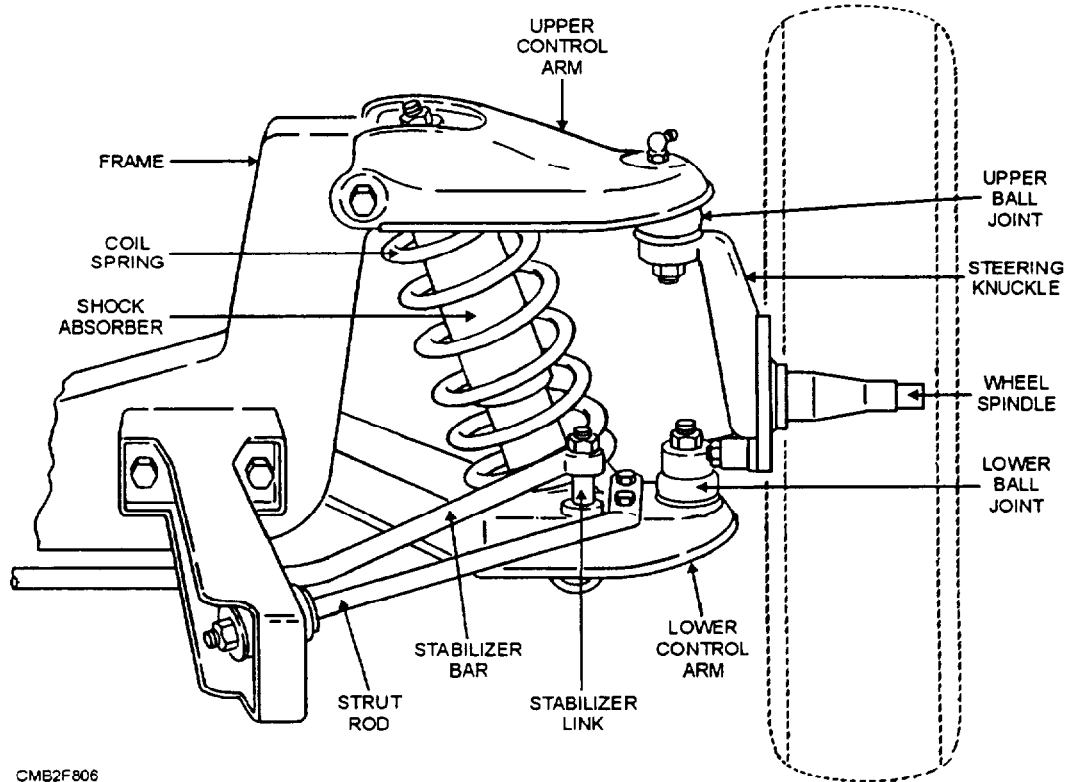

CMB2F806

Figure 8-6.—Independent suspension.

vehicle. With the independent front suspension the use of ball joints provides pivot points for each wheel. In operation, the swiveling action of the ball joints allows the wheel and spindle assemblies to be turned left and right and to move up and down with changes in road surfaces. This type of suspension is most widely used on modern vehicles.

## SUSPENSION SYSTEM COMPONENTS

The basic components of a suspension system are as follows:

- **CONTROL ARM** (a movable lever that fastens the steering knuckle to the vehicle frame or body)
- **CONTROL ARM BUSHING** (a sleeve, which allows the control arm to move up and down on the frame)
- **STRUT ROD** (prevents the control arm from swinging to the front or rear of the vehicle)
- **BALL JOINTS** (a swivel joint that allows the control arm and steering knuckle to move up and down, as well as side to side)
- **SHOCK ABSORBER** or **STRUT** (keeps the suspension from continuing to bounce after spring compression and extension)
- **STABILIZER BAR** (limits body roll of the vehicle during cornering)
- **SPRING** (supports the weight of the vehicle; permits the control arm and wheel to move up and down)

### Control Arms and Bushings

The control arm, as shown in figure 8-6, holds the steering knuckle, bearing support, or axle housing in position, as the wheel moves up and down. The outer end of the control arm has a ball joint and the inner end has bushings. Vehicles, having control arms on the rear suspension, may have bushings on both ends.

The control arm bushings act as bearings, which allows the control arm to move up and down on a shaft bolted to the frame or suspension unit. These bushings may be either pressed or screwed into the openings of the control arm.

### Strut Rods

The strut rod, as shown in figure 8-6, fastens to the outer end of the lower control arm and to the frame.

This prevents the control arm from swinging toward the rear or front of the vehicle. The front of the strut rod has rubber bushings that soften the action of the strut rod. These bushings allow a controlled amount of lower control arm movement while allowing full suspension travel.

### Ball Joints

The ball joints (fig. 8-7) are connections that allow limited rotation in every direction and support the weight of the vehicle. They are used at the outer ends of the control arms where the arms attach to the steering knuckle. In operation, the swiveling action of the ball joints allows the wheel and steering knuckle to be turned left or right and to move up and down with changes in road surface.

Since the ball joint must be filled with grease, a grease fitting and grease seal are normally placed on the joint. The end of the stud on the ball joint is threaded for a large nut. When the nut is tightened, it force fits the tapered stud in the steering knuckle or bearing support.

### Shock Absorbers and Struts

Shock absorbers are necessary because springs do not "settle down" fast enough. After a spring has been compressed and released, it continues to shorten and lengthen for a time. Such spring action on a vehicle would produce a very bumpy and uncomfortable ride. It would also be dangerous because a bouncing wheel makes the vehicle difficult to control; therefore, a dampening device is needed to control the spring

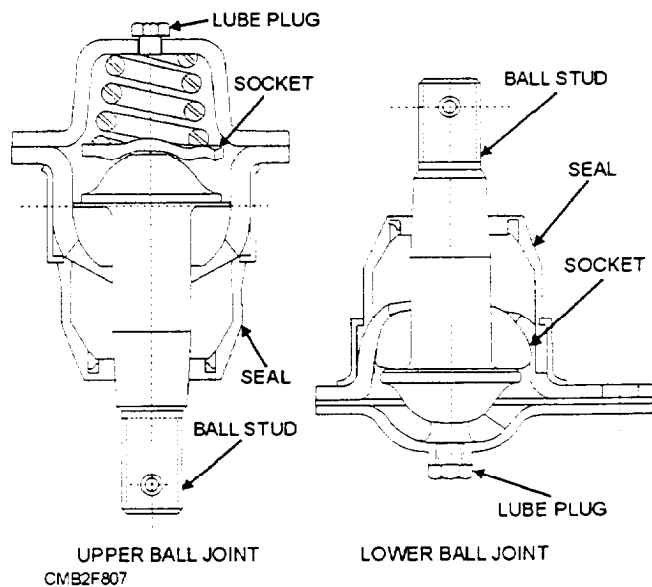

Figure 8-7.—Upper and lower ball joint.

oscillations. This device is the shock absorber. The most common type of shock absorber (fig. 8-8) used on modern vehicles is the double-acting, direct-action type, because it allows the use of more flexible springs.

The direct-action shock absorber consists of an inner cylinder filled with special hydraulic oil divided into an upper and lower chamber by a double-acting piston. In operation, the shock absorbers lengthen and shorten, as the wheels meet irregularities in the road. As they do this, the piston inside the shock absorber moves within the cylinder filled with oil; therefore, the fluid is put under high pressure and forced to flow through small openings. The fluid can only pass through the openings slowly. This action slows piston motion and restrains spring action.

During compression and rebound, the piston is moving. The fluid in the shock absorber is being forced through small openings which restrains spring movement. There are small valves in the shock absorber that open when internal pressure becomes

excessive. When the valves are open, a slightly faster spring movement occurs; however, restraint is still imposed on the spring.

An outer metal cover protects the shock absorber from damage by stones that may be kicked up by the wheels. One end of the shock absorber connects to a suspension component, usually a control arm. The other end fastens to the frame. In this way, the shock absorber piston rod is pulled in and out and resists these movements.

The strut assembly, also called a MacPherson strut, is similar to a conventional shock absorber. However, it is longer and has provisions (brackets and connections) for mounting and holding the steering knuckle (front of vehicle) or bearing support (rear of vehicle) and spring. The strut assembly consists of a shock absorber, coil spring (in most cases), and an upper damper unit. The strut assembly replaces the upper control arm. Only the lower control arm and strut are required to support the front-wheel assembly. The

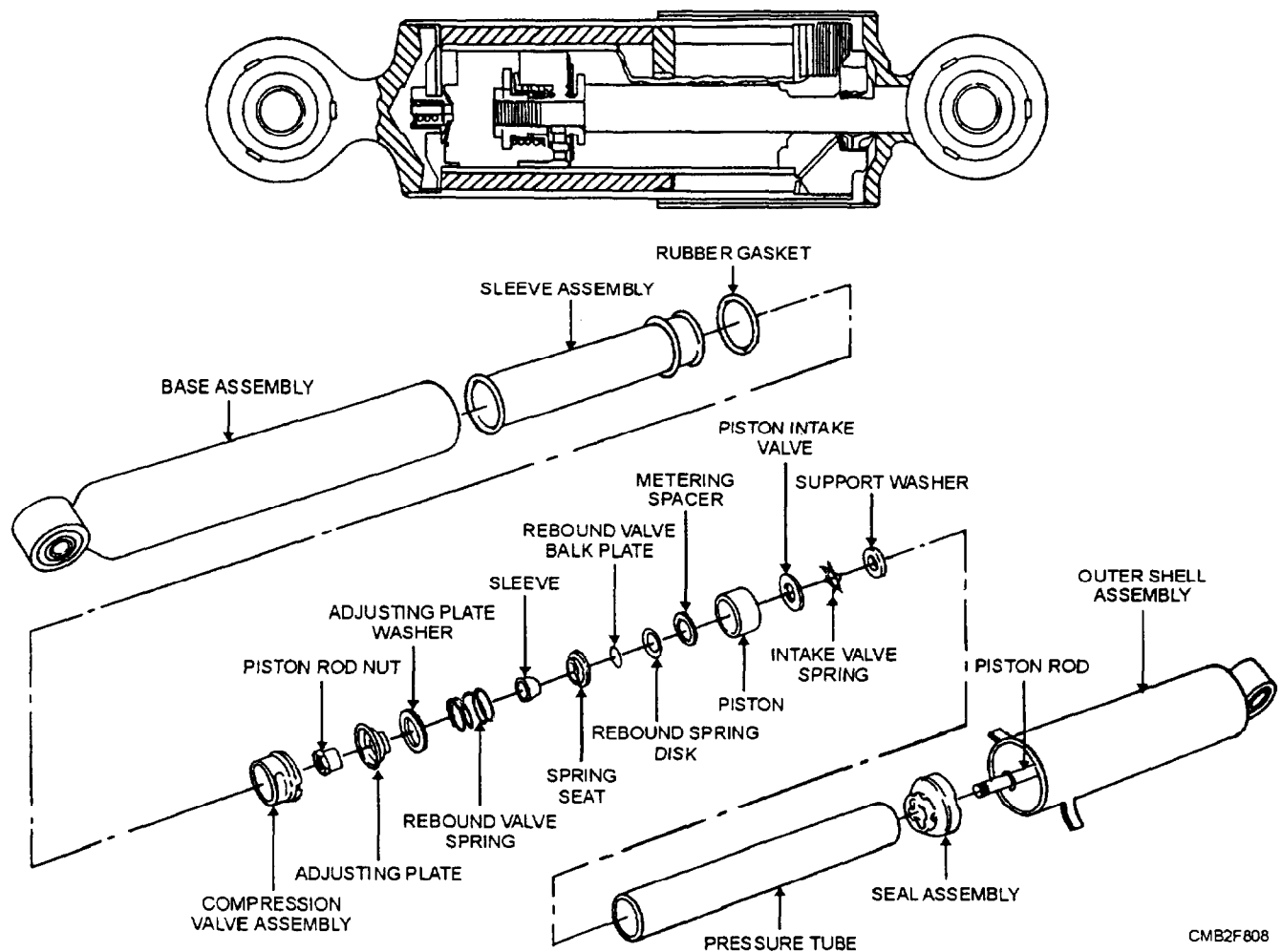

Figure 8-8.—Double-acting, direct-action type shock absorber.

basic components of a typical strut assembly, are as follows (fig. 8-9):

- **STRUT SHOCK ABSORBER**—piston-operated oil-filled cylinder that prevents coil spring oscillations.
- **DUST SHIELD**—metal shroud or rubber boot that keeps road dirt off the shock absorber.
- **LOWER SPRING SEAT**—lower mount formed around the body of the shock absorber for the coil spring.
- **COIL SPRING**—supports the weight of the vehicle and allows for suspension action.
- **UPPER STRUT SEAT**—holds the upper end of the coil spring and contacts the strut bearing.
- **STRUT BEARING**—a ball bearing that allows the shock absorber and coil spring assembly to rotate for steering action.

- **RUBBER BUMPERS**—jounce and rebound bumpers which prevent metal-to-metal contact during extreme suspension compression and extension.
- **RUBBER ISOLATORS**—parts of the strut damper which prevents noise from being transmitted into the body structure of the vehicle.
- **UPPER STRUT RETAINER**—mounting that secures the upper end of the strut assembly to the frame or unitized body.

In a MacPherson strut type suspension, only one control arm and a strut is used to support each wheel assembly. A conventional lower control arm attaches to the frame and to the lower ball joint. The ball joint holds the control arm to the steering knuckle or bearing support. The top of the steering knuckle or bearing support is bolted to the strut. The top of the strut is

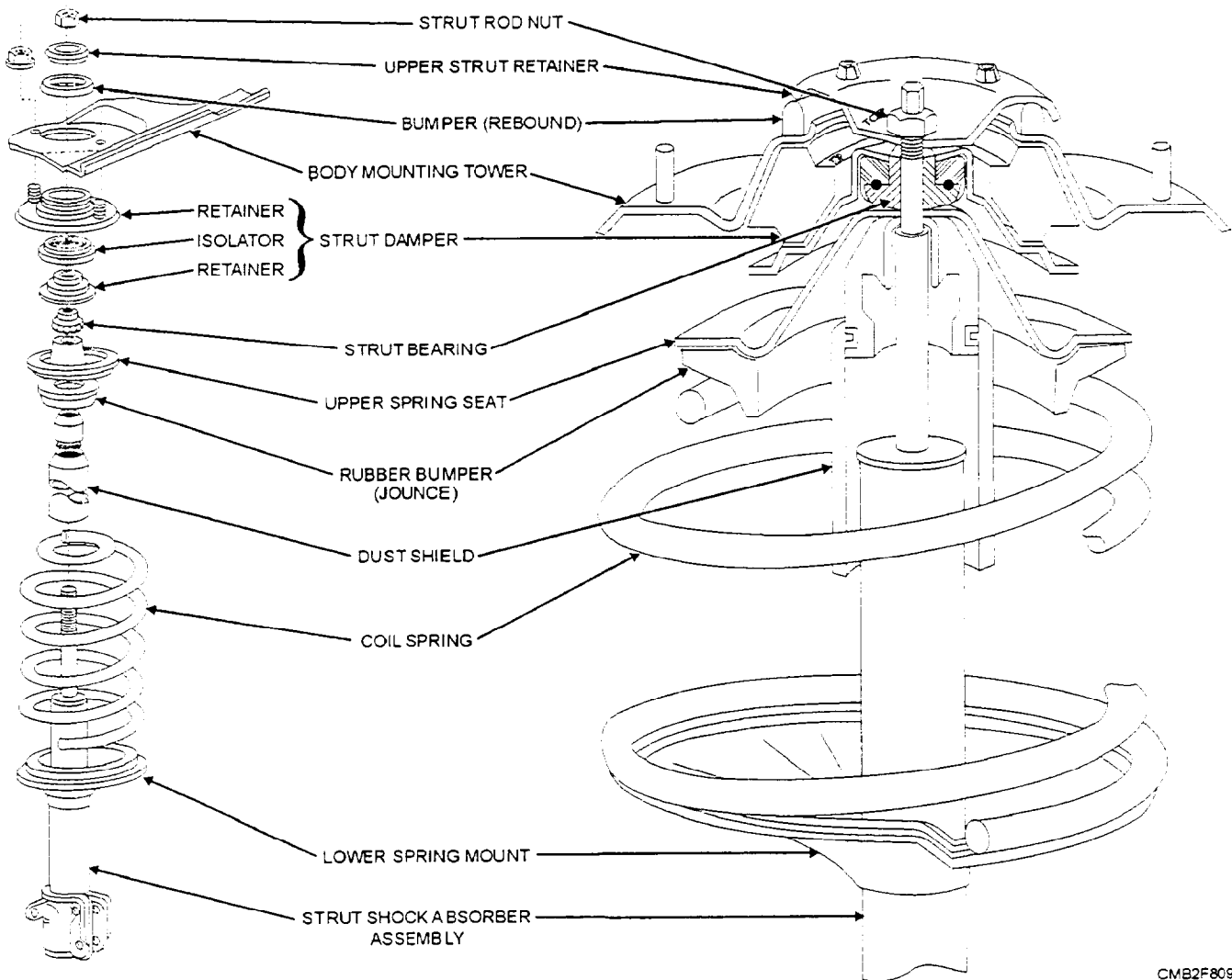

CMB2F809

Figure 8-9.—Exploded and cutaway views of a strut assembly.

bolted to the frame or reinforced body structure. This type of suspension is the most common type used on late model passenger vehicles. The advantages are a reduced number of parts in the suspension system, lower unsprung weight, and a smoother ride.

On some vehicles you may find a **MODIFIED STRUT SUSPENSION** that has the coil springs mounted on the top of the control arm, not around the strut.

### **Stabilizer Bar**

The stabilizer bar, as shown in figure 8-6, also called the sway bar, is used to keep the body of the vehicle from leaning excessively in sharp turns. Made of spring steel, the stabilizer bar fastens to both lower control arms and to the frame. Rubber bushings fit between the stabilizer bar, the control arms, and the frame.

When the vehicle rounds a corner, centrifugal force tends to keep the vehicle moving in a straight line. Therefore, the vehicle “leans out” on the turn. This lean out is also called a body roll. With lean out, or body roll, additional weight is thrown on the outer spring. This puts additional compression on the outer spring, and the control arm pivots upward. As the control arm pivots upward, it carries its end of the stabilizer bar up with it. At the inner wheel on the turn, there is less weight on the spring. Weight has shifted to the outer spring because of centrifugal force. Therefore, the inner spring tends to expand. The expansion of the inner spring tends to pivot the lower control arm downward. As this happens, the lower control arm carries its end of the stabilizer bar downward.

The outer end of the stabilizer bar is carried upward by the outer control arm. The inner end is carried downward. This combined action twists the stabilizer bar. This action twists the stabilizer bar and its resistance to this twisting action limits body lean in corners.

### **SUSPENSION SYSTEM SPRINGS**

The vehicle body or frame supports the weight of the engine, the power train, and the passengers. The body and frame is supported by the springs on each wheel. The weight of the frame, body, and attached components applies an initial compression to the springs. The springs compress further as the wheels of the vehicle hit bumps or expand such as when the wheels drop into a hole in the road. The springs cannot do the complete job of absorbing road shocks. The tires

absorb some of the irregularities in the road. The springs in the seats of the vehicle also help absorb shock. However, the passengers feel little shock from road bumps and holes.

The ideal spring for an automotive suspension should absorb road shock rapidly and then return to its normal position slowly; however, this action is difficult to attain. An extremely flexible, or soft, spring allows too much movement. A stiff, or hard, spring gives too rough a ride. To attain the action to produce satisfactory riding qualities, use a fairly soft spring with a shock absorber.

### **Spring Terminology**

There are three basic types of automotive springs—coil, leaf, and torsion bar. Before discussing these types of springs, you must understand three basic terms—spring rate, sprung weight, and unsprung weight.

- **SPRING RATE** refers to the stiffness or tension of a spring. The rate of a spring is the weight required to deflect it 1 inch. The rate of most automotive springs is almost constant through their operating range, or deflection, in the vehicle. Hooke’s law, as applied to coil springs states: that a spring will compress in direct proportion to the weight applied. Therefore, if 600 pounds will compress a spring 3 inches, then 1,200 pounds will compress the spring twice as far, or 6 inches.

- **SPRUNG WEIGHT** refers to the weight of the parts that are supported by the springs and suspension system. Sprung weight should be kept **HIGH** in proportion to unsprung weight.

- **UNSPRUNG WEIGHT** refers to the weight of the components that are **NOT** supported by the springs. The tires, wheels, wheel bearings, steering knuckles, or axle housing is considered unsprung weight. Unsprung weight should be kept **LOW** to improve ride smoothness. Movement of high unsprung weight (heavy wheel and suspension components) will tend to transfer movement into the passenger compartment.

The coil spring is made of round spring steel wound into a coil (fig. 8-10). Because of their simplicity, they are less costly to manufacture and also have the widest application. This spring is more flexible than the leaf spring, allowing a smoother reaction when passing over irregularities in the road. Coil springs are frictionless and require the use of a shock absorber to dampen vibrations. Their cylindrical

shape requires less space to operate in. Pads are sometimes used between the spring and the chassis to eliminate transferring vibrations to the body. Because of its design, the coil spring cannot be used for torque reaction or absorbing side thrust. Therefore, control arms and stabilizers are required to maintain the proper geometry between the body and suspension system. This is the most common type of spring found on modern suspension systems.

Coil spring mountings are quite simple in construction. The hanger and spring seat are shaped to fit the coil ends and hold the spring in place. Cups that fit snugly on each coil end are often used for mounting. The upper cup can be formed within the frame, in the control arms, or part of a support bracket rigidly fixed to the cross member or frame rail. The lower cup is fastened to a control arm hinged to a cross member or frame rail. Rubber bumpers are included on the lower spring support to prevent metal-to-metal contact between the frame and control arm, as the limits of compression are reached.

### Leaf Spring

The leaf spring acts as a flexible beam on self-propelled vehicles and transmits the driving and breaking forces to the frame from the axle assembly. Leaf springs are semi-elliptical in shape and are made of high quality alloy steel. There are two types of leaf springs—single leaf and multileaf (fig. 8-11). The single leaf spring, or monoleaf, is a single layer spring

that is thick in the center and tapers down at each end. Single leaf springs are used in lighter suspension systems that do not carry great loads. A multileaf spring is made up of a single leaf with additional leaves. The additional leaves make the spring stiffer, allowing it to carry greater loads.

The most common type is the multileaf spring (fig. 8-12) that consists of a single leaf with a number of additional leaves attached to it using spring clips. Spring clips, also known as rebound clips, surround the leaves at intervals along the spring to keep the leaves from separating on the rebound after the spring has been depressed. The clips allow the springs to slide, but prevent them from separating and causing the entire rebound stress to act on the master leaf. The multileaf spring uses an insulator (frictional material) between the leaves to reduce wear and eliminate any squeaks that might develop. To keep the leaves equally spaced lengthwise, use a center bolt for the multileaf spring. The center bolt rigidly holds the leaves together in the middle of the spring, preventing the leaves from moving off center. Each end of the largest leaf is rolled into an eye, which serves as a means of attaching the spring to the vehicle. Leaf springs are attached to the vehicle using a spring hanger that is rigidly mounted to the frame in the front and the spring shackle in the rear, which allows the spring to expand and contract without binding as it moves through its arc. Bushings and pins provide the bearing or support points for the vehicle. Spring bushings may be made of bronze or rubber and are pressed into the spring eye. The pins that pass

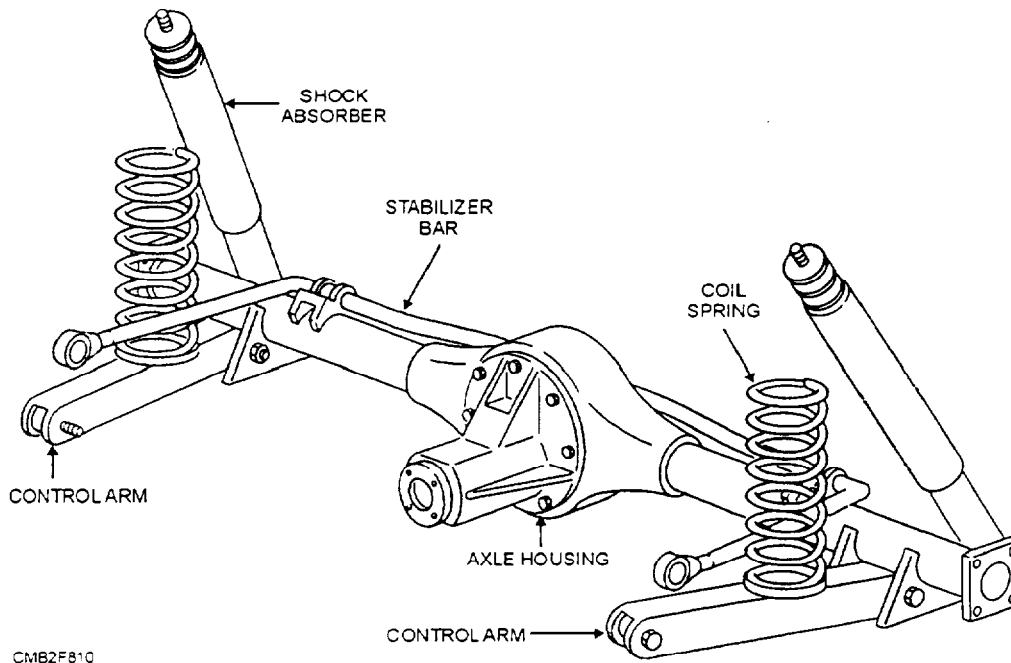
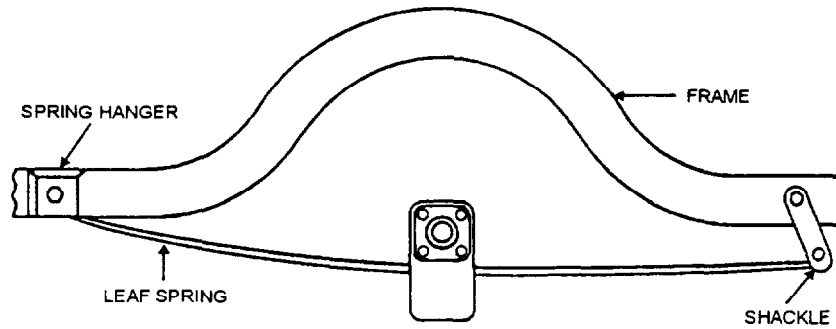
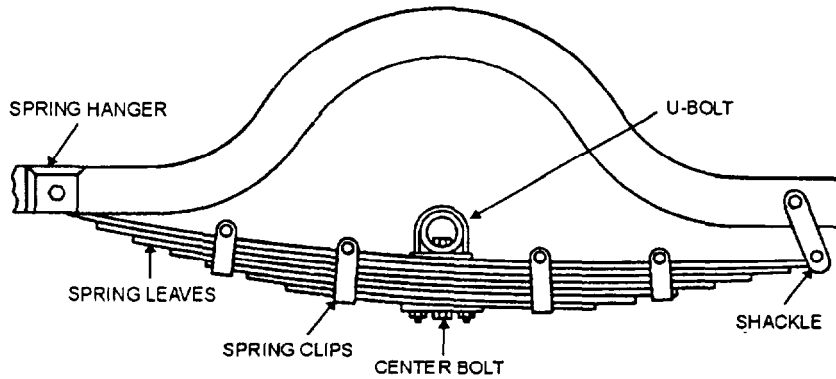

Figure 8-10.—Coil springs.



A. SINGLE LEAF SPRING



B. MULTILEAF SPRING

CMB2F811

Figure 8-11.—Leaf springs.

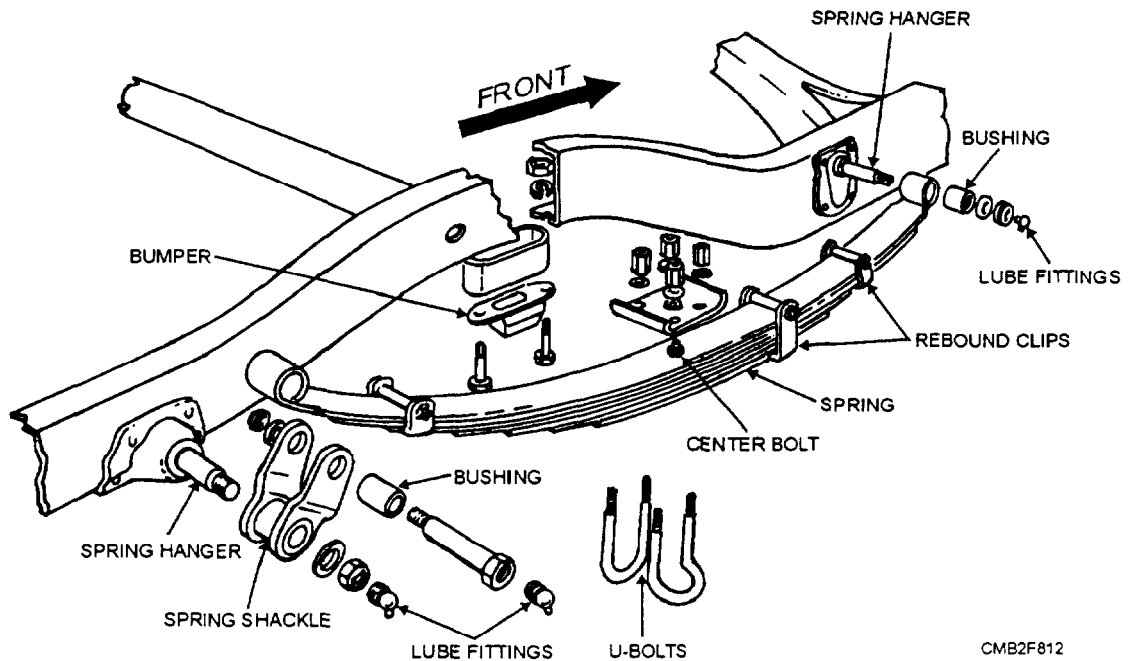

CMB2F812

Figure 8-12.—Multileaf spring.

through the bushings may be plain or threaded. Threaded bushings and pins offer a greater bearing surface and are equipped with lubrication fittings.

Leaf springs are used on the front and rear of heavy-duty trucks and the rear of passenger vehicles

and light trucks. Trucks that carry a wide variety of loads use an auxiliary or overload spring. This auxiliary spring (fig. 8-13) may be mounted on top of the rear springs and clamped together with long U-bolts, or it may be located under the axle separate

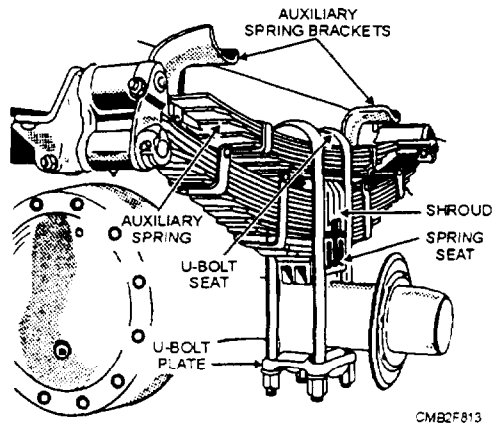

Figure 8-13.—Auxiliary spring.

from the main spring. In either case, the ends of the spring has it own support brackets. When the truck is under a load, the auxiliary spring assumes part of the load when its ends contact the bearing plates or special brackets attached to the frame side rails.

A large portion of six-wheel drive vehicles utilize a bogie suspension (fig. 8-14) which uses leaf springs. This suspension is a unit consisting of two axles joined by torque rods. A trunnion axle acts as a pivot for the drive axles and is supported by bearings that are part of the spring seat. The ends of each spring rest in the guide brackets bolted to the axle housings. Mounting the springs on central pivots enable them to distribute half of the rear load onto each axle. As a result, this type of suspension allows the vehicle to carry a much

heavier load than a single axle without losing its ability to move over unimproved terrain.

When one wheel of a bogie suspension is moved up or down because of an irregularity in the road, the spring pivots on the trunnion shaft and both ends of the spring deflect to absorb the road shock. This causes the load to be placed on the center of the spring resulting in equal distribution of the load to both axles. The torque rods ensure proper spacing and alignment of the axles and transmit the driving and braking forces to the frame.

### Torsion Bar

The torsion bar consists of a steel rod made of spring steel and treated with heat or pressure to make it elastic, so it will retain its original shape after being twisted. Torsion bars, like coil springs, are frictionless and require the use of shock absorbers. The torsion bar is serrated on each end and attached to the torsion bar anchor at one end and the suspension system at the other end (fig. 8-15). Torsion bars are marked to indicate proper installation by an arrow stamped into the metal. It is essential that they be installed properly because they are designed to take the stress in one direction only. The up-and-down movement of the suspension system twists the steel bar. The torque resistance will return the suspension to its normal position in the same manner as a spring arrangement.

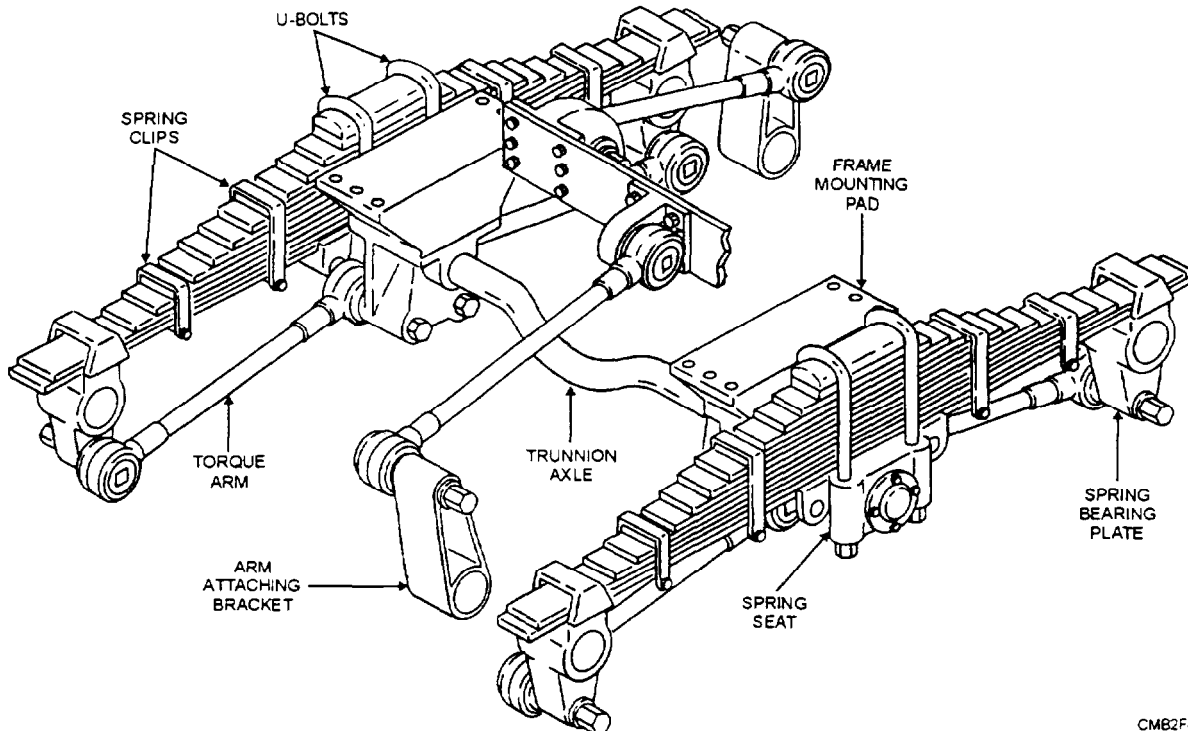

Figure 8-14.—Bogie suspension.



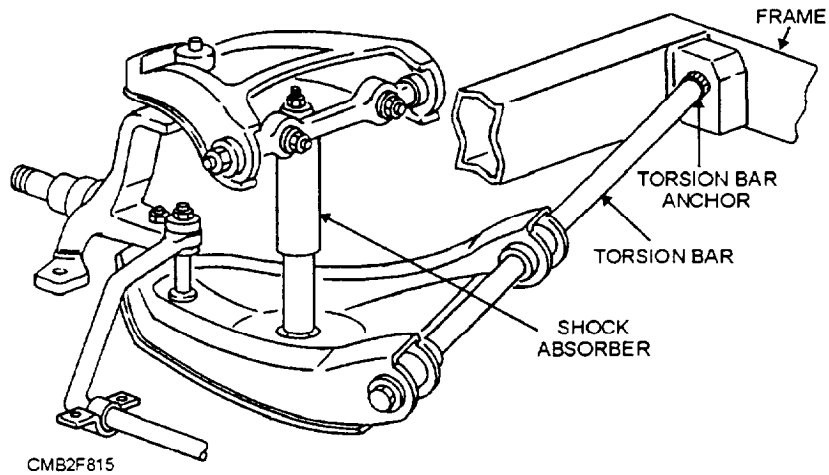

Figure 8-15.—Torsion bar.

## SUSPENSION SYSTEM SERVICE

A suspension system takes a tremendous "pounding" during normal vehicle operation. Bumps and potholes in the road surface cause constant movement, fatigue, and wear of the shock absorbers, or struts, ball joints, bushings, springs, and other components. Suspension system problems usually show up as abnormal noises (pops, squeaks, and clunks), tire wear, steering wheel pull, or front end shimmy (side-to-side vibration). Suspension system wear can upset the operation of the steering system and change wheel alignment angles. Proper service and maintenance of these components greatly increase roadability, reliability, and vehicle life.

### Suspension Bushing Service

Rubber bushings are commonly used in the inner ends of front control arms and rear control arms. These bushings are prone to wear and should be inspected periodically.

Worn control arm bushings can let the control arms move sideways. This action causes tire wear and steering problems. To check for control arm bushing wear, try to move the control arm against normal movement. For example, pry the control arm back and forth while watching the bushings. If the control arm moves in relation to its shaft, the bushings are worn and must be replaced.

Generally, to replace the bushings in a front suspension requires the removal of the control arm. This usually requires the separation of the ball joints and compression of the coil spring. The stabilizer bar and strut rod are also unbolted from the control arm. The bolts passing through the bushings are then removed which allows for the control arm to be

removed from the vehicle. With the control arm placed in a vise, either press or screw out the old bushings and install new ones.

With new bushings installed, replace the control arm in reverse order. Torque all bolts to the manufacturer's specifications. Install the ball joints cotter pin. Check the manufacturer's service manual for information concerning preloading control arm bushings.

### NOTE

Always refer to the manufacturer's service manual for exact directions and specifications. This will assure a safe, quality ride.

### Ball Joint Service

Worn ball joints cause the steering knuckle and wheel assembly to be loose on the control arm. A worn ball joint may make a clunking or popping sound when turning or driving over a bump. Ball joint wear is usually the result of improper lubrication or prolonged use. The load-carrying ball joints support the weight of the vehicle while swiveling into various angles. If the joints are improperly lubricated (dry), the swiveling action will cause them to wear out quickly.

Grease fittings are provided for ball joint lubrication. If the ball joint has a lube plug, it must be removed and replaced with a grease fitting. Using a hand-powered grease gun, inject only enough grease to fill the boot of the ball joint. Do not overfill the boot, because too much grease will rupture the boot. A ruptured boot will allow dirt to enter the joint, which causes them to wear out quicker.

Ball joints can be checked for wear while the wheel is supported, as shown in figures 8-16 and 8-17. Axial play or tolerance, also called vertical movement, is checked by moving the wheel straight up and down. The actual amount of play in a ball joint is measured with a dial indicator. Figure 8-18 shows the dial indicator clamped to the lower control arm. The dial indicator tip rests against the leg of the steering knuckle. With a pry bar, try to raise and lower the steering knuckle. If you use too much force, the ball joint may give you a false reading. You want to measure the movement of the wheel and ball joint, as the joint is moved up to the LOAD position. Note the movement as indicated on the dial indicator.

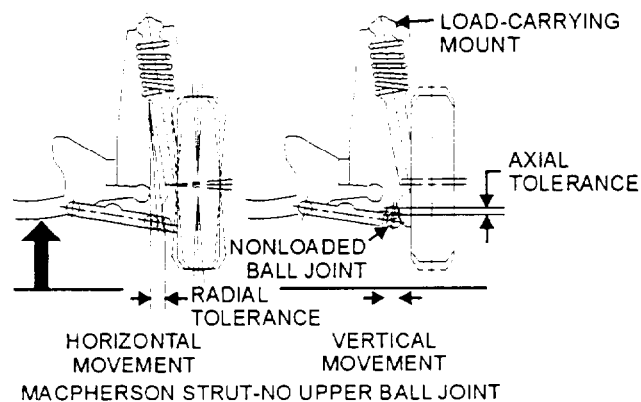

CMB2F816

Figure 8-16.—Support points for checking ball joints in various front suspension systems using coil springs.

Rocking the wheel in and out at the top and bottom checks radial play or tolerance. This action also is known as horizontal movement. Grasp the tire at the top and bottom, and try to wobble it. However, now we are assuming that the wheel bearings have been checked and either adjusted or properly tightened. Therefore, we are now checking the horizontal movement of the ball joints. Some manufacturers do not accept horizontal movement as an indicator of ball joint wear.

The actual specifications for allowable wear limits of the ball joints are listed in the manufacturer's service manual. Refer to the specifications for the vehicle you are checking. Any ball joint should be replaced if there is excessive play.

Ball joint replacement can usually be done without removing the control arm. Generally, place the vehicle on jack stands. Remove the shock absorber and install a spring compressor on the coil spring. Unbolt the steering knuckle and separate the steering knuckle and

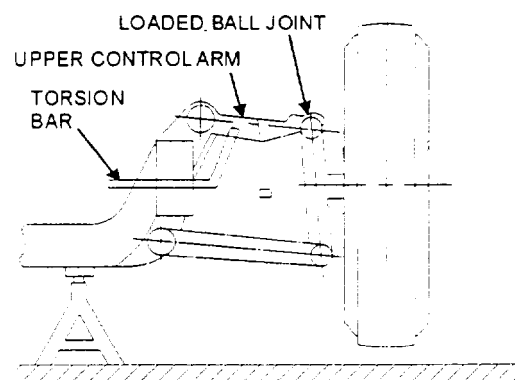

TORSION BAR ON UPPER CONTROL ARM

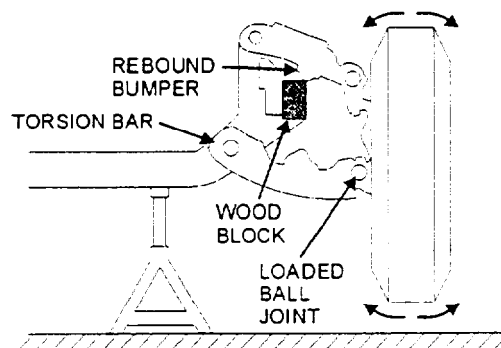

TORSION BAR ON LOWER CONTROL ARM

CMB2F817

Figure 8-17.—Support points for checking ball joints in front suspension system using torsion bars.

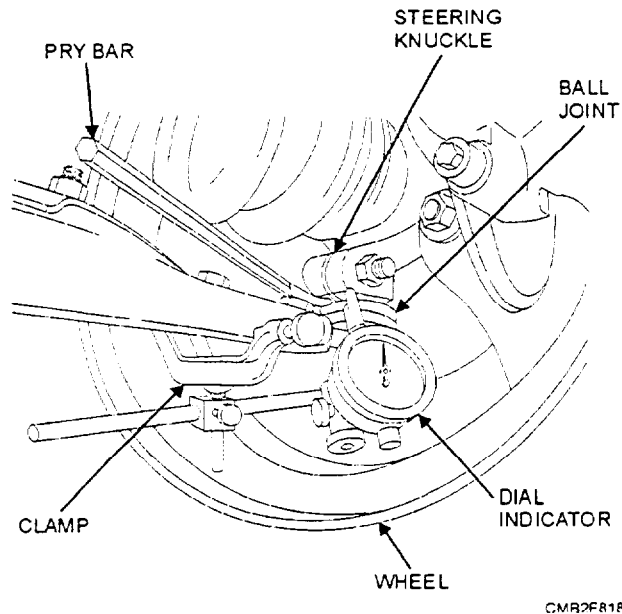

Figure 8-18.—A dial indicator mounted to measure the amount of play in a ball joint.

ball joint. The ball joint may be pressed, riveted, bolted, or screwed into the control arm. If the ball joint is riveted to the control arm, replace the rivets with bolts.

#### NOTE

For exact ball joint removal and installation procedures, consult the manufacturer's service manual.

### Shock Absorber Service

Worn shock absorbers will cause the vehicle to ride poorly on rough roads. When the tire strikes a bump, a bad shock will not dampen spring oscillations. The suspension system will continue to rebound and bounce. This move is then transferred to the frame, the body, and the passenger compartment.

Loose or damaged shocks produce a loud clanking or banging sound. The rapid up-and-down movement of the suspension can hammer the loose shock absorber against the body, the shock tower, or the control arm.

To check shock absorber condition, locate any problems with a bounce test and a visual inspection. To perform a shock absorber bounce test, simply push up and down on each corner of the vehicle body. Then release the body and count the number of times the vehicle moves up and down. Generally a GOOD shock absorber should stop movement in two to three

rebounds. A BAD shock absorber will let the body bounce over three times.

Visually inspect the shock absorbers for any signs of leakage (oily wetness) and damage. Also, check the bushing on each end of the shock for being smashed or split. Make sure that the shock absorber fasteners are tight. When shock absorber replacement is required, ALWAYS replace them as a pair, even if but one is defective. This action ensures the riding equilibrium of the vehicle.

#### NOTE

For instructions on removal and installation of shock absorbers, refer to the manufacturer's service manual.

#### CAUTION

With many suspension systems, you must place jack stands or lift devices under the control arms or axle when replacing the shock absorbers. This will keep the control arms or axle from flying downward when the shock is unbolted.

### Strut Service

The most common trouble with a strut type suspension is worn shock absorbers. Just like conventional shock absorbers, the pistons and cylinders inside the struts can begin to leak. This reduces the dampening action and the vehicle rides poorly. As with the conventional shock absorber when a strut shock absorber leaks, it must be replaced, and ALWAYS as a pair.

Basically, strut removal involves unbolting the steering knuckle (front suspension) or bearing support (rear suspension), any brake lines, and the upper strut assembly-to-body fasteners. Remove the strut assembly (coil spring and shock) as a single unit.

#### CAUTION

Do NOT remove the nut on the end of the shock rod or the unit can fly apart.

A strut spring compressor is required to remove the coil spring from the strut. After the coil spring is compressed, remove the upper damper assembly. With the upper damper assembly removed, release the tension on the coil spring and lift the spring off the strut. Inspect all parts closely for damage.

## WARNING

When compressing any suspension system spring, be extremely careful to position the spring compressor properly. If the spring were to pop out of the compressor, serious injuries or death could result.

With the coil spring and upper damper unit removed, you can now remove the shock cartridge. A new shock cartridge can be installed in the strut outer housing to restore the strut to perfect condition. Some manufacturers recommend that the strut shock absorber be rebuilt once the strut shock absorber is repaired or replaced. The strut can be reassembled and installed in reverse order of disassembly.

## NOTE

For exact procedures for the removal, repair, and installation of a strut assembly, refer to the manufacturer's service manual.

## Spring Service

Springs require very little periodic service. Leaf spring service usually involves bushing replacement. Torsion bars require adjustment and coil springs require no periodic service.

Spring service requirements can be found in the service manual of the vehicle you are working on.

Spring fatigue (weakening) can occur after prolonged service. The fatigue lowers the height of the vehicle, allowing the body to settle toward the axles. This settling or sagging changes the position of the control arms, resulting in misalignment of the wheels. This condition also affects the ride and appearance of the vehicle.

To check spring condition or torsion bar adjustment, measure CURB HEIGHT (distance from a point on the vehicle to the ground). Place the vehicle on a level surface. Then measure from a service manual specified point on the frame, body, or suspension down to the shop floor. Compare the measurement to the specifications in the service manual. If the curb height is too low (measurement too small), replace the fatigued springs or adjust the torsion bar.

## NOTE

For instructions on the removal and installation of springs, refer to the manufacturer's service manual.

The vehicle should also be at CURB WEIGHT when checking spring condition and curb height. Curb weight is generally the total weight of the vehicle with a full tank of fuel and no passengers or cargo. Also, make sure nothing is in the passenger compartment that could possibly increase curb weight. Curb weight is given in pounds or kilograms.

## REVIEW 2 QUESTIONS

- Q1. What component of the suspension system prevents the control arm from swinging to the front or rear of the vehicle?*
- Q2. In the suspension system, what is the function of the stabilizer bar?*
- Q3. At what location on the control arm is the ball joint attached?*
- Q4. What is the most common type of shock absorber used on modern vehicles?*
- Q5. On a vehicle that uses struts on the front, the struts replace what suspension component?*
- Q6. What term is used to describe the stiffness or tension of a spring?*
- Q7. The radial play of a ball joint can be checked by moving the wheel straight up and down. (T/F)*
- Q8. What tool is required to remove the coil spring from the strut?*

## STEERING SYSTEM

**Learning Objective:** Identify the major components of a steering system. Explain the operating principles of steering systems. Describe the differences between the linkage and rack and pinion type steering. Describe the operation of power steering. Describe service and repair procedures for manual and rack and pinion type steering mechanisms. Explain the service procedures for servicing power steering belts, hoses, and fluid.

The steering system allows the operator to guide the vehicle along the road and turn left or right as desired. The system includes the steering wheel, which the operator controls, the steering mechanism, which changes the rotary motion of the steering wheel into straight-line motion, and the steering linkage. Most systems were manual until a few years ago. Then power steering became popular. It is now installed in most vehicles manufactured today. The steering

system must perform several important functions, which are as follows:

- Provide precise control of front-wheel direction.
- Maintain the correct amount of effort needed to turn the front wheels.
- Transmit road feel (slight steering wheel pull caused by road surface) to the operator's hands.
- Absorb most of the shock going to the steering wheel, as the tires hit bumps and holes in the road.
- Allow for suspension action.

## STEERING LINKAGE

Steering linkage is a series of arms, rods, and ball sockets that connect the steering mechanism to the steering knuckles. The steering linkage used with most manual and power steering mechanisms typically includes a pitman arm, center link, idler arm, and two tie-rod assemblies. This configuration of linkage is known as parallelogram steering linkage (fig. 8-19) and is used on many passenger vehicles.

### Pitman Arm

The pitman arm transfers steering mechanism motion to the steering linkage (fig. 8-19). The pitman arm is splined to the steering mechanism's output shaft (pitman arm shaft). A large nut and lock washer secure the pitman arm to the output shaft. The outer end of the

pitman arm normally uses a ball-and-socket joint to connect to the center link.

### Center Link

The parallelogram steering linkage (fig. 8-19) uses a center link, otherwise known as an intermediate rod, track rod, or relay rod, which is simply a steel bar that connects the steering arms (pitman arm, tie-rod ends, and idler arm) together. The turning action of the steering mechanism is transmitted to the center link through the pitman arm.

### Idler Arm

The center link is hinged on the opposite end of the pitman arm by means of an idler arm (fig. 8-19). The idler arm supports the free end of the center link and allows it to move left and right with ease. The idler arm bolts to the frame or subframe.

### Ball Sockets

Ball sockets (fig. 8-19) are like small ball joints; they provide for motion in all directions between two connected components. Ball sockets are needed so the steering linkage is NOT damaged or bent when the wheels turn or move up and down over rough roads. Ball sockets are filled with grease to reduce friction and wear. Some have a grease fitting that allows chassis grease to be inserted with a grease gun. Others are sealed by the manufacturer and cannot be serviced.

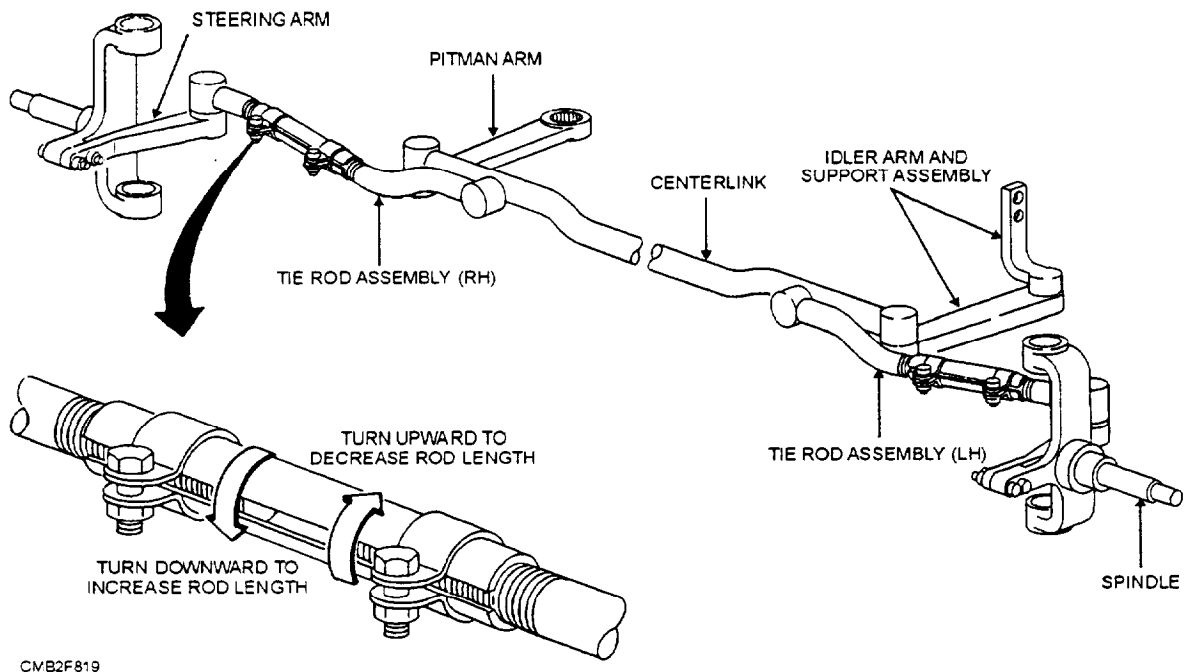

Figure 8-19.—Parallelogram steering linkage.

## Tie-Rod Assemblies

Two tie-rod assemblies (fig. 8-19) are used to fasten the center link to the steering knuckles. Ball sockets are used on both ends of the tie-rod assembly. An adjustment sleeve connects the inner and outer tie rods. These sleeves are tubular in design and threaded over the inner and outer tie rods. The adjusting sleeves provide a location for toe adjustment. Clamps and clamp bolts are used to secure the sleeve. Some manufacturers require the clamps be placed in a certain position in relation to the tie rod top or front surface to prevent interference with other components.

## STEERING RATIO

One purpose of the steering mechanism is to provide mechanical advantage. In a machine or mechanical device, it is the ratio of the output force to the input force applied to it. This means that a relatively small applied force can produce a much greater force at the other end of the device.

In the steering system, the operator applies a relatively small force to the steering wheel. This action results in a much larger steering force at the front wheels. For example, in one steering system, applying 10 pounds to the steering wheel can produce up to 270 pounds at the wheels. This increase in steering force is produced by the steering ratio.

The steering ratio is a number of degrees that the steering wheel must be turned to pivot the front wheels 1 degree. The higher the steering ratio (30:1 for example), the easier it is to steer the vehicle, all other things being equal. However, the higher steering ratio, the more the steering wheel has to be turned to achieve steering. With a 30:1 steering ratio, the steering wheel must turn 30 degrees to pivot the front wheels 1 degree.

Actual steering ratio varies greatly, depending on the type of vehicle and type of operation. High steering ratios are often called slow steering because the steering wheel has to be turned many degrees to produce a small steering effect. Low steering ratios, called fast or quick steering require much less steering wheel movement to produce the desired steering effect.

Steering ratio is determined by two factors—steering-linkage ratio and the gear ratio in the steering mechanism. The relative length of the pitman arm and the steering arm determines the steering linkage ratio. The steering arm is bolted to the steering spindle at one end and connected to the steering linkage at the other.

When the effective lengths of the pitman arm and the steering arm are equal, the linkage has a ratio of 1:1. If the pitman arm is shorter or longer than the steering arm, the ratio is less than or more than 1:1. For example, the pitman arm is about twice as long as the steering arm. This means that for every degree the pitman arm swings, the wheels will pivot about 2 degrees. Therefore, the steering linkage ratio is about 1:2.

Most of the steering ratio is developed in the steering mechanism. The ratio is due to the angle or pitch of the teeth on the worm gear to the angle or pitch on the sector gear. Steering ratio is also determined somewhat by the effective length and shape of the teeth on the sector gear.

In a rack-and-pinion steering system, the steering ratio is determined largely by the diameter of the pinion gear. The smaller the pinion, the higher the steering ratio. However, there is a limit to how small the pinion can be made.

## MANUAL STEERING SYSTEMS

Manual steering is considered to be entirely adequate for smaller vehicles. It is tight, fast, and accurate in maintaining steering control. However, larger and heavier engines, greater front overhang on larger vehicles, and a trend toward wide tread tires have increased the steering effort required. Steering mechanisms with higher gear ratios were tried, but dependable power steering systems were found to be the answer. There are several different types of manual steering systems, which are as follows:

- Worm and sector
- Worm and rotter
- Cam and lever
- Worm and nut
- Rack and pinion

### Worm and Sector

In the worm and sector steering gear (fig. 8-20), the pitman arm shaft carries the sector gear that meshes with the worm gear on the steering gear shaft. Only a sector of gear is used because it turns through an arc of approximately 70 degrees. The steering wheel turns the worm on the lower end of the steering gear shaft, which rotates the sector and the pitman arm through the use of the shaft. The worm is assembled between tapered rotter bearings that take up the thrust and load.

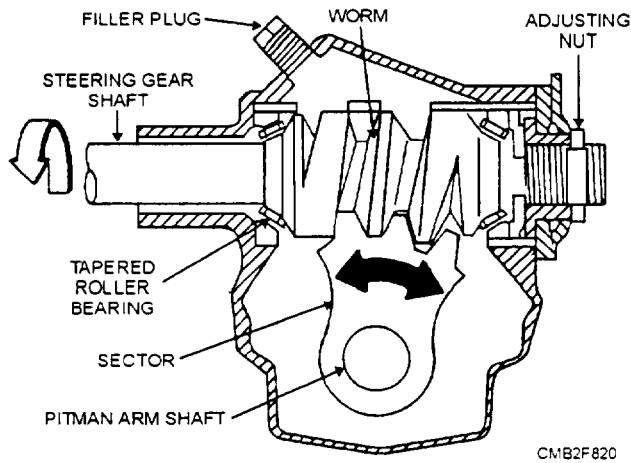

Figure 8-20.—Worm and sector steering gear.

An adjusting nut or plug is provided for adjusting the end play of the worm gear.

### Worm and Roller

The worm and roller steering gear (fig. 8-21) is quite similar to the worm and sector, except a roller is supported by ball or roller bearings within the sector mounted on the pitman arm shaft. These bearings assist in reducing sliding friction between the worm and sector. As the steering wheel turns the worm, the roller turns with it, forcing the sector and pitman arm shaft to rotate.

The hourglass shape of the worm, which tapers from both ends to the center, affords better contact between the worm and roller in all positions. This design provides a variable steering ratio to permit faster and more efficient steering.

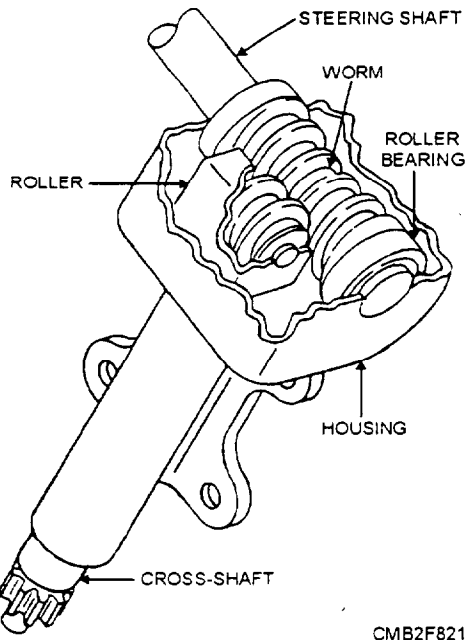

Figure 8-21.—Worm and roller steering gear.

"Variable steering ratio" means that the ratio is larger at one position than another. Therefore the wheels are turned faster at certain positions than at others. At the center or straight-ahead position, the steering gear ratio is high, giving more steering control. However, as the wheels are turned, the ratio decreases so that the steering action is much more rapid. This design is very helpful for parking and maneuvering the vehicle.

### Cam and Lever

The cam and lever steering gear, in which the worm is known as a cam and the sector as the lever, is shown in figure 8-22. The lever carries two studs that are mounted in bearings and engage the cam. As the steering wheel is turned, the studs move up and down on the cam. This action causes the lever and pitman arm shaft to rotate. The lever moves more rapidly as it nears either end of the cam. This action is caused by the increased angle of the lever in relation to the cam. Like the worm and roller, this design allows for variable steering ratio.

### Worm and Nut

The worm and nut steering gear is made in several different combinations. A nut is meshed with and screws up and down on the worm gear. The nut may operate the pitman arm directly through a lever or through a sector on the pitman arm shaft.

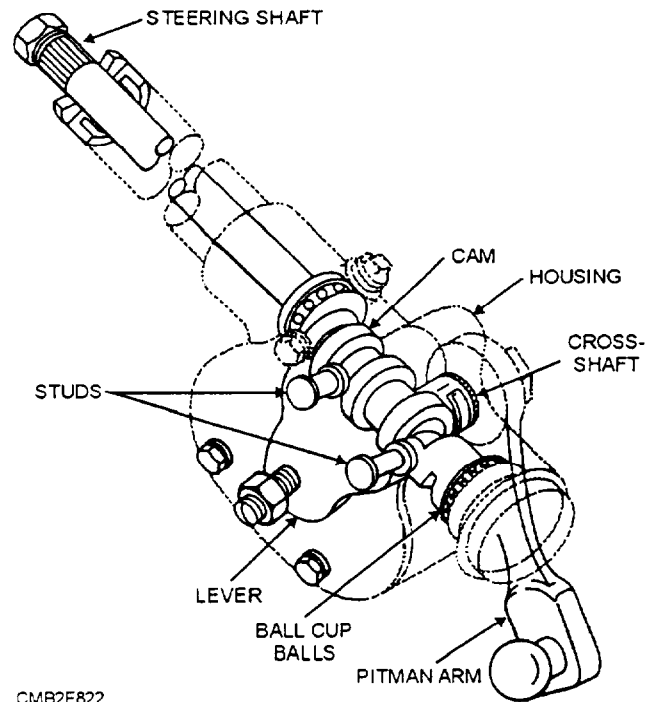
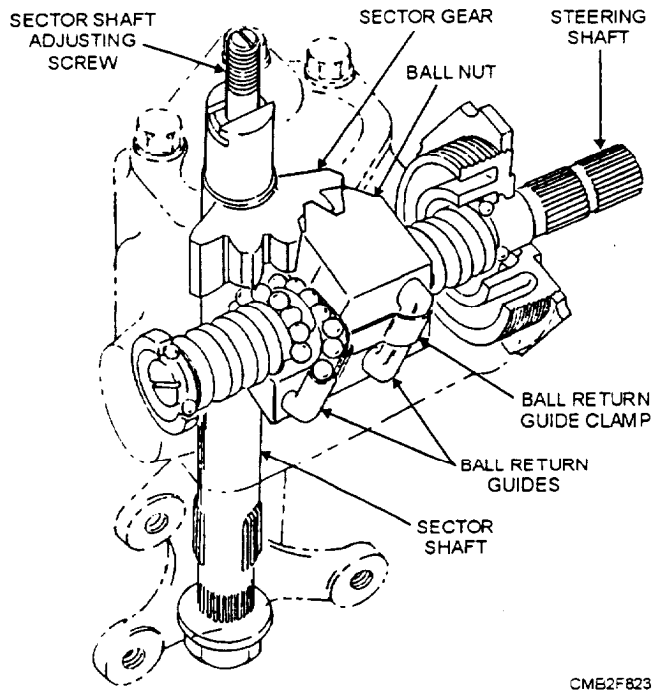

Figure 8-22.—Cam and lever steering gear

The recirculating ball is the most common type of worm and nut steering gear (fig. 8-23). In this steering gear, the nut, which is in the form of a sleeve block, is mounted on a continuous row of balls on the worm gear to reduce friction. Grooves are cut into the ball nut to match the shape of the worm gear. The ball nut is fitted with tubular ball guides to return the balls diagonally across the nut to recirculate them, as the nut moves up



CME2F823

Figure 8-23.—Worm and nut steering gear (recirculating ball type).

and down on the worm gear. With this design, the nut is moved on the worm gear by rolling instead of sliding contact. Turning the worm gear moves the nut and forces the sector and pitman arm shaft to turn.

### Rack and Pinion

The rack-and-pinion steering gear has become increasingly popular on smaller passenger vehicles. It is simpler, more direct acting, and may be straight mechanical or power-assisted.

The manual rack-and-pinion steering gear basically consists of a steering gear shaft, pinion gear, rack, thrust spring, bearings, seals, and gear housing. In the rack-and-pinion steering system the end of the steering gear shaft contains a pinion gear, which meshes with a long rack (fig. 8-24). The rack is connected to the steering arms by tie rods, which are adjustable for maintaining proper toe angle. The thrust spring preloads the rack-and-pinion gear teeth to prevent excessive gear backlash. Thrust spring tension may be adjusted by using shims or an adjusting screw.

As the steering wheel is rotated, the pinion gear on the end of the steering shaft rotates. The pinion gear moves the rack from one side to the other. This action pushes or pulls on the tie rods, forcing the steering knuckles or wheel spindles to pivot on their ball joints. This turns the wheels to one side or the other so the vehicle can be steered.

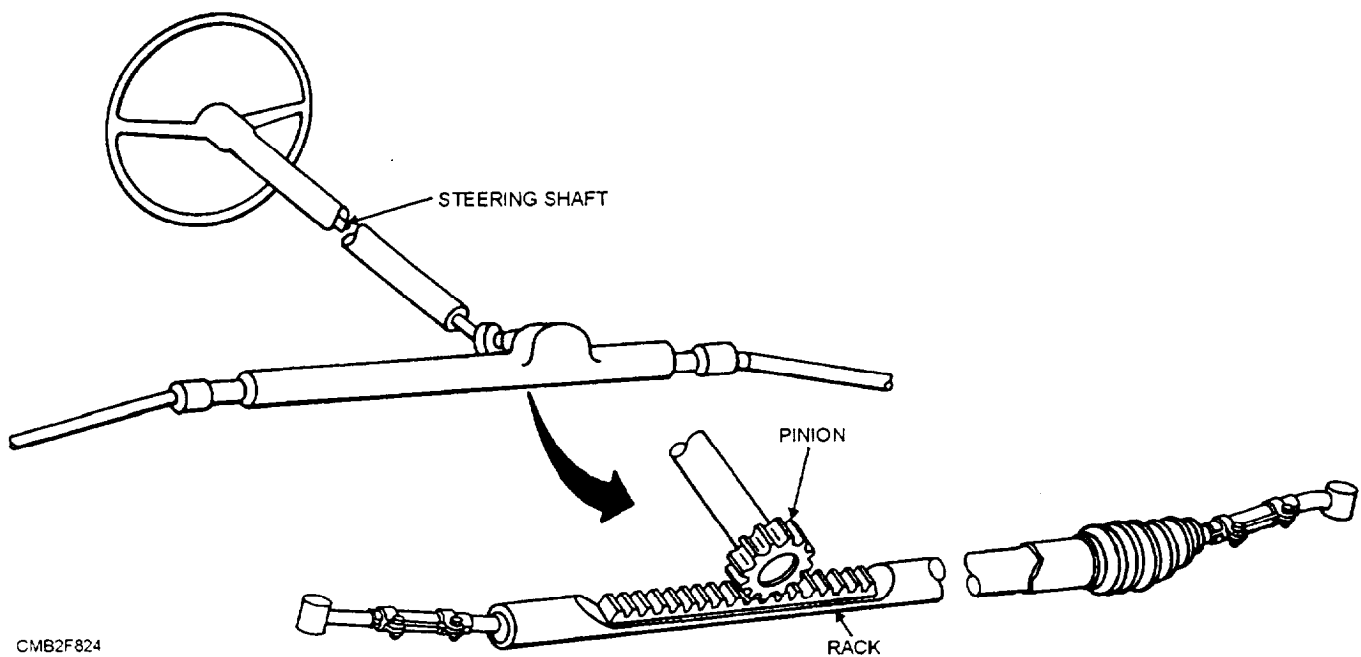

CMB2F824

Figure 8-24.—Rack-and-pinion steering gear.



## POWER STEERING SYSTEMS

Power steering systems normally use an engine-driven pump and hydraulic system to assist steering action. Pressure from the oil pump is used to operate a piston and cylinder assembly. When the control valve routes oil pressure into one end of the piston, the piston slides in its cylinders. Piston movement can then be used to help move the steering system components and front wheels of the vehicles.

The components that are common to all power steering systems are as follows:

- **POWER STEERING PUMP** (fig. 8-25)—The power steering pump is engine-driven and supplies hydraulic fluid under pressure to the other components

in the system. There are four basic types of power steering pumps—vane, roller, slipper, and gear types. A belt running from the engine crankshaft pulley normally powers the pump. During pump operation, the drive belt turns the pump shaft and pumping elements. Oil is pulled into one side of the pump by vacuum. The oil is then trapped and squeezed into a smaller area inside the pump. This action pressurizes the oil at the output, as it flows to the rest of the system. A pressure relief/flow valve is built into the pump to control maximum oil pressure. This action prevents system damage by limiting pressure developed throughout the different engine speeds.

- **CONTROL VALVE** (fig. 8-26)—The control valve (rotary or spool type), which is actuated by steering wheel movements, is designed to direct the

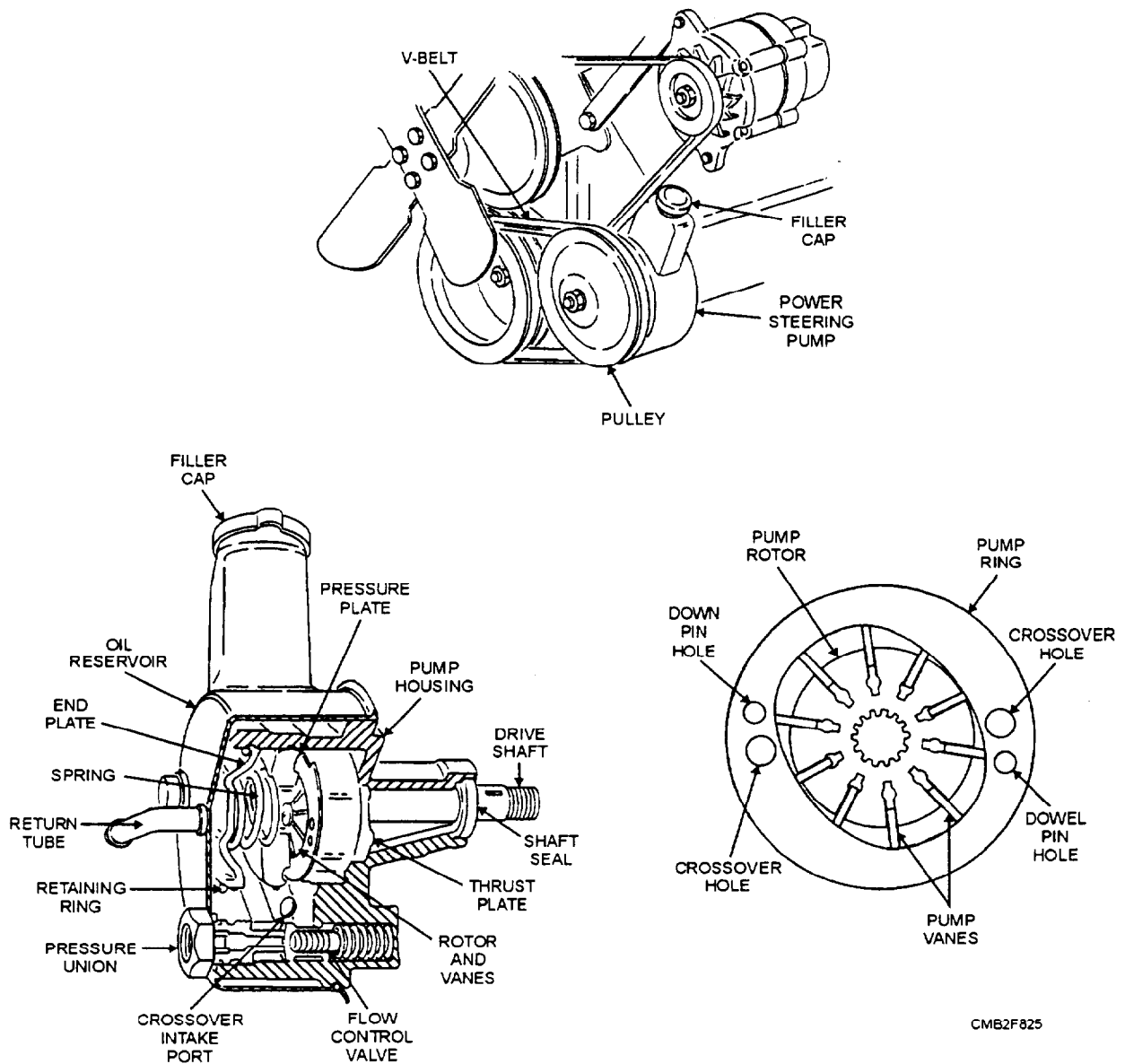

Figure 8-25.—Typical power steering pump.

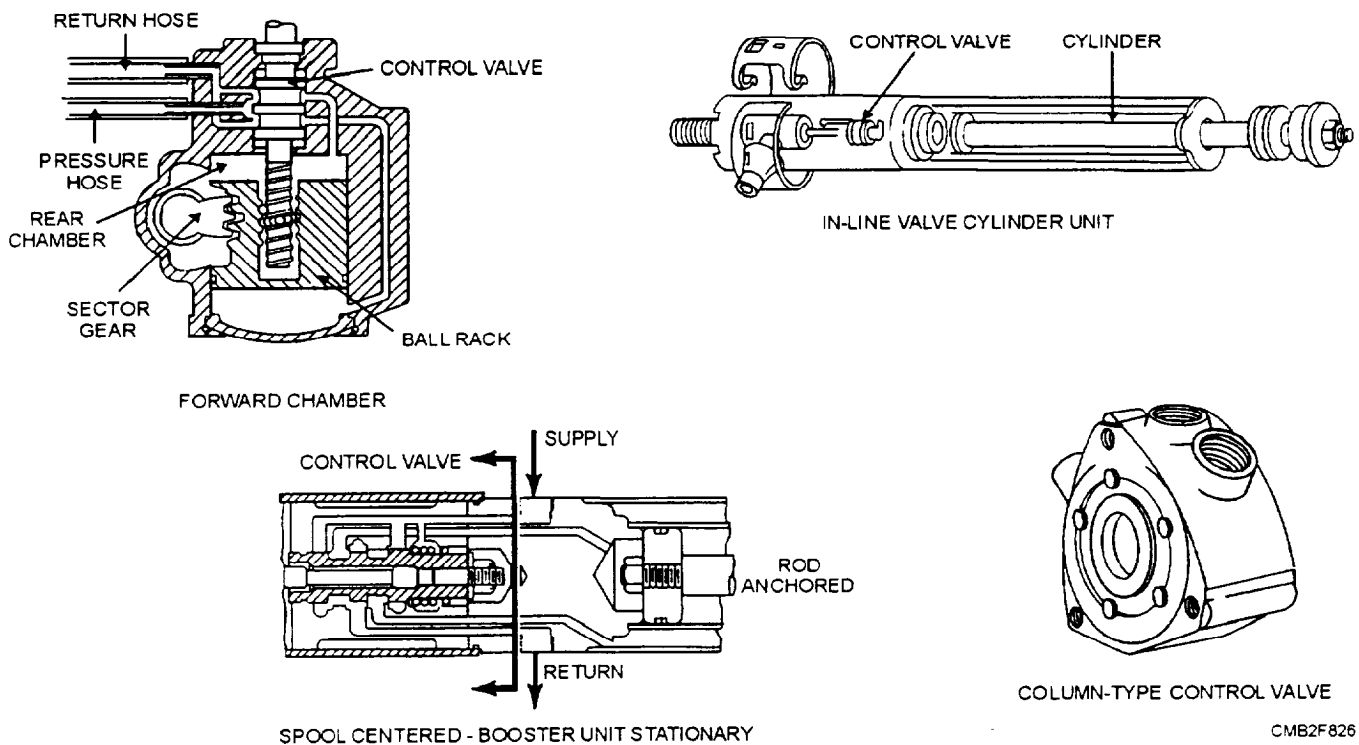

Figure 8-26.—Control valve.

hydraulic fluid under pressure to the proper location in the steering system. The control valve may be mounted either in the steering mechanism or on the steering linkage, depending on which system configuration is used.

- **POWER STEERING HOSES**—Power steering hoses are high-pressure, hydraulic rubber hoses that connect the power steering pump and the integral gearbox or power cylinder. One line serves as a supply line, the other acts as a return line to the reservoir of the power steering pump.

There are three major types of power steering systems used on modern passenger vehicles (fig. 8-27)—integral piston (linkage type), external cylinder (linkage type), and rack and pinion. The rack and pinion can further be divided into integral and external power piston. The integral rack and pinion steering system is the most common.

### Integral Piston (Linkage Type)

The integral piston (linkage type) power steering system has the hydraulic piston mounted inside the steering gearbox. This is the most common type of power steering system. Basically, this system consists

of a power steering pump, hydraulic lines, and a special integral power-assist gearbox.

The integral piston power steering gearbox (fig. 8-28) contains a conventional worm and sector gear arrangement, a hydraulic piston, and a control valve. The control valve may be either a spool valve or a rotary valve depending upon manufacturer.

The operation of an integral power steering system is as follows:

- With the steering wheel held straight ahead or in NEUTRAL position, the control valve balances hydraulic pressure on both sides of the power piston. Oil returns to the pump reservoir from the control valve.
- For a right turn, the control valve routes oil to the left side of the power piston. The piston is pushed to the right in the cylinder to aid pitman shaft rotation.
- For a left turn, the control valve routes oil to the right side of the power piston. The piston is pushed to the left in the cylinder to aid pitman shaft rotation.

In both left and right turns piston movement forces oil on the nonpressurized side of the piston back through the control valve and to the pump.

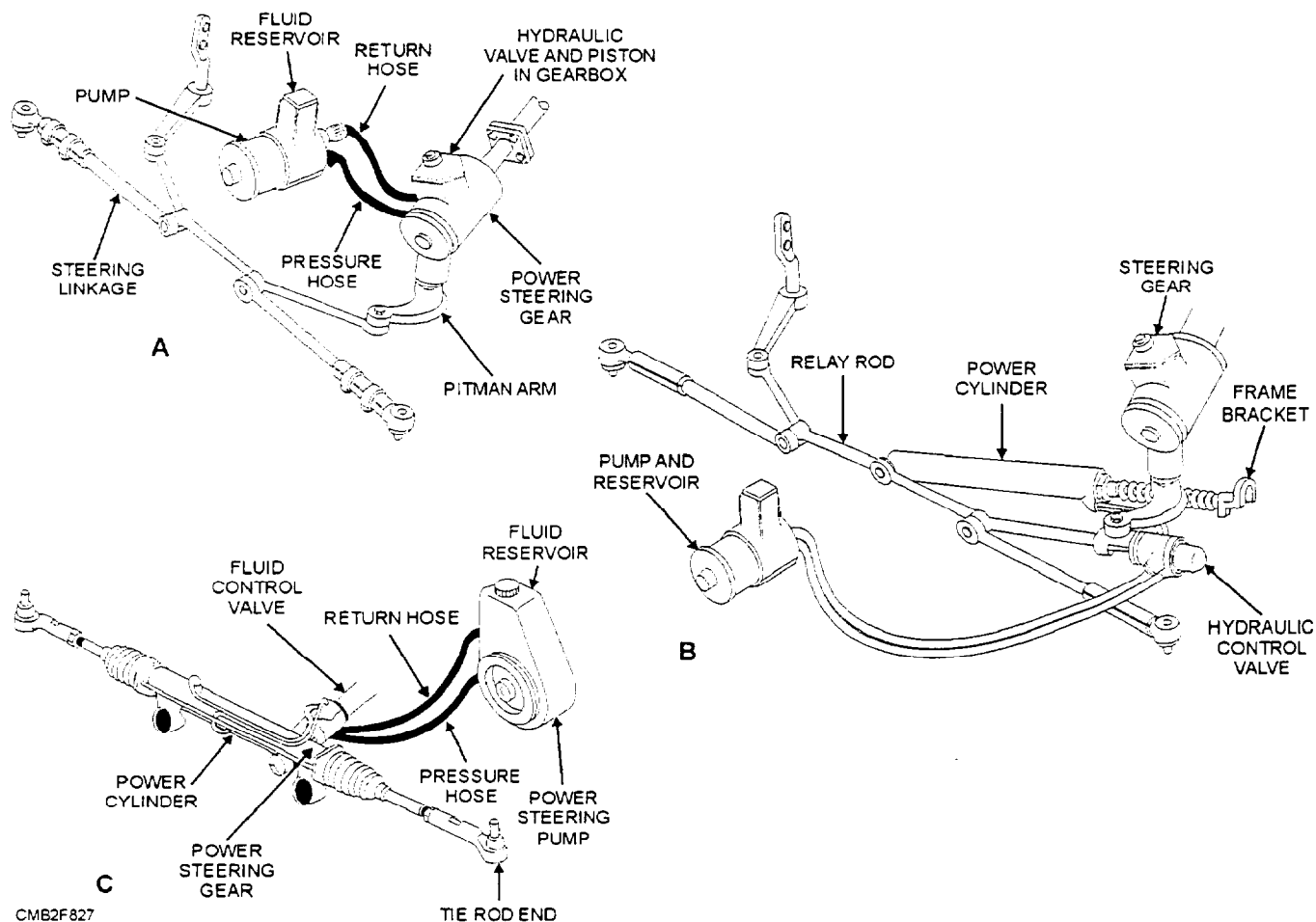

Figure 8-27.—The three major power steering systems. (A) Integral piston (linkage type), (B) External cylinder (linkage type), and (C) Rack and pinion type.

### External Cylinder (Linkage Type)

The external cylinder power steering system has the power cylinder mounted to the frame and the center link. In this system the control valve may be located in the gearbox or on the steering linkage. Operation of this system is similar to the one previously described.

### Power Rack and Pinion

Power rack-and-pinion steering uses hydraulic pump pressure to assist the operator in moving the rack and front wheels. A basic power rack-and-pinion assembly consists of the following:

- **POWER CYLINDER** (hydraulic cylinder formed around the rack)—The power cylinder is precisely machined to accept the power piston. Provisions are made for the hydraulic lines. The power cylinder bolts to the vehicle frame, just like the rack of a manual unit.
- **POWER PISTON** (a double-acting hydraulic piston formed on the rack)—The power piston is

formed by attaching a hydraulic piston to the center of the rack. A rubber seal fits around the piston to prevent fluid from leaking from one side of the power cylinder to the other.

- **HYDRAULIC LINES** (steel tubing that connects the control valve and power cylinder).
- **CONTROL VALVE** (a hydraulic valve which regulates hydraulic pressure entering each end of the power piston)—There are two types of control valves—rotary and spool. Using a torsion bar connected to the pinion gear operates the rotary valve, whereas the spool valve is operated by the thrust action of the pinion shaft.
- Other components of the power rack and pinion are similar to those that are found on manual rack-and-pinion steering system.

Power rack-and-pinion operation is fairly simple. When the steering wheel is turned, the weight of the vehicle causes the front tire to resist turning. This resistance twists a torsion bar (rotary valve) or thrusts

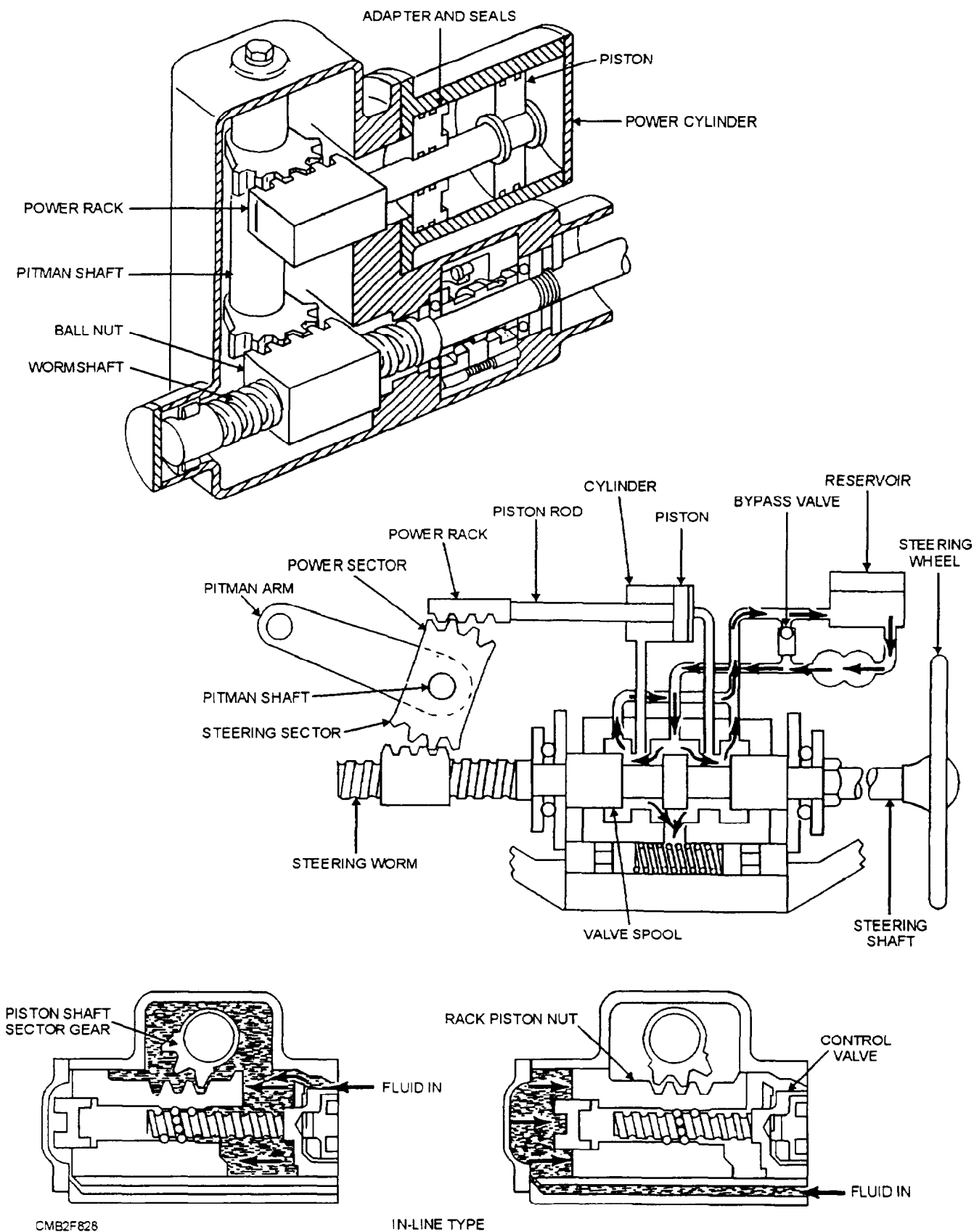

CMB2F828

Figure 8-28.—Power steering gearbox.

the pinion shaft (spool valve) slightly. This action moves the control valve and aligns the specific oil passages. Pump pressure is then allowed to flow through the control valve, the hydraulic line, and into the power cylinder. Hydraulic pressure then acts on the power piston and the piston action assists in pushing the rack and front wheels for turning.

## **STEERING SYSTEM MAINTENANCE**

Maintenance of the steering system consists of regular inspection, lubrication, and adjusting components to compensate for wear. When inspecting the steering system, you will need someone to assist you by turning the steering wheel back and forth through the free play while you check the steering linkage and connections. You will also be able to determine if the steering mechanism is securely fastened to the frame. A slight amount of free play may seem insignificant, but if allowed to remain, the free play will quickly increase, resulting in poor steering control.

After prolonged use, steering components can fail. It is important that the steering system be kept in good working condition for obvious safety reasons. It is your job to find and correct any system malfunctions quickly and properly

### **Steering Linkage Service**

Any area containing a ball-and-socket joint is subjected to extreme movements and dirt. The combination of these two will cause the ball-and-socket joint to wear. When your inspection finds worn steering linkage components, they must be replaced with new components. Two areas of concern are the idler arm and the tie-rod ends.

**IDLER ARM SERVICE.**—A worn idler arm causes play in the steering wheel. The front wheels, mostly the right wheel, can turn without causing movement of the steering wheel. This is a very common wear point in the steering linkage and should be checked carefully.

To check an idler arm for wear, grab the outer end of the arm (end opposite the frame) and force it up and down by hand. Note the amount of movement at the end of the arm and compare it to the manufacturer's specifications. Typically, an idler arm should NOT move up and down more than 1/4 inch.

The replacement of a worn idler arm is as follows:

- Separate the outer end of the arm from the center link. A ball joint fork or puller can be used to force the idler arms joint from the center link.

- With the outer end removed from the center link, unbolt and remove the idler arm from the frame.

- Install the new idler arm in reverse order of removal. Make sure that all fasteners are torqued to manufacturer's specifications. Install a new cotter pin and bend it properly.

**TIE-ROD END SERVICE.**—A worn tie-rod end will also cause steering play. When movement is detected between the ball stud and the socket, replacement is necessary.

The replacement of a worn tie-rod end is as follows:

- Separate the tie rod from the steering knuckle or center link. As with the idler arm, a ball joint fork or puller can be used.

- With the tie rod removed from the steering knuckle or center link, measure tie-rod length. This will allow you to set the new tie rod at about the same length as the old one.

### **NOTE**

The alignment of the front wheel is altered when the length of the tie rod is changed.

- Loosen and unscrew the tie-rod adjustment sleeve from the tie-rod end. Turn the new tie-rod end into the adjustment sleeve until it is the exact length of the old tie rod.

- Install the tie-rod ball stud into the center link or steering knuckle. Tighten the fasteners to manufacturer's specifications. Install new cotter pins and bend correctly. Tighten the adjustment sleeve and check steering action.

### **Manual Steering System Service**

Steering system service normally involves the adjusting or replacement of worn parts. Service is required when the worm shaft rotates back and forth without normal pitman arm shaft movement. This would indicate that there is play inside the gearbox. If excess clearance is NOT corrected after the adjustments, the steering gearbox must be replaced or rebuilt.

**MANUAL GEARBOX ADJUSTMENT.**—Since there are numerous steering gearbox configurations, we will discuss the most common type, recirculating ball and nut. There are two basic adjustments—worm bearing preload and over center clearance.

- **WORM BEARING PRELOAD**—Assures that the worm shaft is held snugly inside the gearbox housing. If the worm shaft bearings are too loose, the worm shaft can move sideways and up and down during operation.

- **OVER CENTER CLEARANCE**—Controls the amount of play between the pitman arm shaft gear (sector) and the teeth on the ball nut. It is the most critical adjustment affecting steering wheel play.

#### NOTE

Set the worm bearing preload first and then the over center clearance.

The basic procedures for adjusting worm-bearing preload are as follows:

- Disconnect the pitman arm from the pitman arm shaft. Loosen the pitman arm shaft overcenter adjusting locknut and screw out the adjusting screw a couple of turns. Then turn the steering wheel from side to side slowly.

- Using a torque wrench or spring scale, measure the amount of force required to turn the steering wheel to the CENTER position. Note the reading on the torque wrench or the spring scale and compare it to the manufacturer's specifications.

- If readings are out of specifications, loosen the worm-bearing locknut. Then tighten the worm bearing adjustment nut to increase the preload. Loosen it to decrease preload and turning effort. With the preload set to specifications, tighten the locknut. Make sure the steering wheel turns freely from stop to stop.

#### NOTE

If the steering wheel binds or feels rough, then the gearbox has damaged components and should be rebuilt or replaced.

The basic procedures for adjusting the over center clearance are as follows:

- Find the CENTER position of the steering wheel. This is done by turning the steering wheel from full right to full left while counting the number of turns. Divide the number of turns by two to find the middle. This allows you to turn the steering wheel from full stop to the center.

#### NOTE

Most gearboxes are designed to have more gear tooth backlash (clearance) when turned to the right or left. A slight preload is produced in the center position to avoid steering wheel play during straight-ahead driving.

- With the steering wheel centered, loosen the over center adjusting screw locknut. Turn the over center adjusting screw in until it bottoms lightly. This will remove the backlash.

- Using the instructions in the service manual, measure the amount of force required to turn the steering wheel. Loosen or tighten the adjustment screw to meet the manufacturer's specifications. Tighten the locknut and recheck the gearbox action.

When adjustment fails to correct the problems, the steering gearbox needs to be overhauled or replaced. Overhauling a gearbox is done by disassembling, cleaning, inspecting, replacing worn components, and seals. After reassembling the gearbox, fill the housing with the correct type of lubricant. Most manual steering systems use SAE 90 gear oil. Make sure that you do NOT overfill the gearbox. Refer to the manufacturer's service manual for the particular gearbox you are working on since procedures, specifications, and type of lubricants vary.

**RACK-AND-PINION SERVICE.**—Rack-and-pinion steering systems have few parts that fail. When problems do develop, they are frequently in the tie-rod ends. When NOT properly lubricated, the rack and pinion will also wear, causing problems.

Depending upon the manufacturer, some rack-and-pinion steering systems need periodic lubrication. Others only need lubrication when the unit is being reassembled after being repaired.

Most rack-and-pinion systems have a rack guide adjustment screw. This screw is adjusted when there is excessive play in the steering. Basic procedure for adjusting rack-and-pinion steering system is as follows:

- Loosen the locknut on the adjusting screw. Then turn the rack guide screw until it bottoms slightly. Back off the rack guide screw the recommended amount (approximately 45 degrees or until the prescribed turning effort is achieved).

- Tighten the locknut. Check for tight or loose steering and measure steering effort. Compare with the manufacturer's specifications. If not with

specifications, an overhaul of the system will be required.

- For instructions on the removal/installation and overhaul of the rack-and-pinion system, refer to the manufacturer's service manual for the equipment you are repairing.

### Power Steering System Service

Many of the components of a power steering system are the same as those used on a manual steering system. However, a pump, hoses, a power piston, and a control valve are added. These components can also fail, requiring repair or replacement. Power steering system service typically consists of the following:

- Checking power steering fluid level
- Checking belts and hoses
- Checking the system for leaks
- Pressure testing the system
- Bleeding the system

#### **CHECKING POWER STEERING FLUID.—**

To check the level of the power steering fluid, you should NOT let the engine run. With the parking brake set, place the transmission in either PARK or NEUTRAL. Basic procedures for checking the level of the power steering fluid are as follows:

- Unscrew and remove the cap to the power steering reservoir. The cap will normally have a dipstick attached.
- Wipe off the dipstick and reinstall the cap. Remove the cap and inspect the level of the fluid on the dipstick. Most dipsticks will have HOT and COLD markings. Make sure you read the correct marking on the dipstick.

#### **NOTE**

The fluid level will rise on the dipstick as the steering system warms.

If required, only add enough fluid to reach the correct mark on the dipstick. Automatic transmission fluid is commonly used in a power steering system. Some power steering systems, however, do NOT use automatic transmission fluid and require a special power steering fluid. Always refer to the manufacturer's service for the correct type of fluid for your system.

#### **CAUTION**

Do NOT overfill the system. Overfilling will cause fluid to spray out the top of the reservoir and onto the engine and other components.

**SERVICING POWER STEERING HOSES AND BELT.—**Always inspect the condition of the hoses and the belt very carefully.

The hoses are exposed to tremendous pressures; if a hose ruptures, a sudden and dangerous loss of power assist occurs. Make sure that the hose is NOT rubbing on moving or hot components. This can cause hose failure.

#### **CAUTION**

Power steering pump pressure can exceed 1,000 psi. This is enough pressure to cause serious eye injury. Wear eye protection when working on a power steering system.

If it is necessary to replace a power steering hose, use a flare nut or tubing wrench. This action will prevent you from stripping the nut. When starting a new hose fitting, use your hand. This action will prevent cross threading. Always tighten the hose fitting properly.

A loose power steering belt can slip, causing belt squeal and erratic or high steering effort. A worn or cracked belt may break during operation, which would cause a loss of power assist.

When it is necessary to tighten a power steering belt, do NOT pry on the side of the power steering pump. The thin housing on the pump can easily be dented and ruined. ONLY pry on the reinforced flanged or a recommended point.

The basic procedures for installing a power steering belt are as follows:

- Loosen the bolts that hold the power steering pump to its brackets.
- Push inward on the pump to release tension on the belt. With the tension removed, slide the belt from the pulley.

Obtain a new belt and install it in reverse order. Remember when adjusting belt tension to specifications, only pry on the reinforced flange or a recommended pry point.

**POWER STEERING LEAKS.—**A common problem with power steering systems is fluid leakage. With pressure over 1,000 psi, leaks can develop easily

around fittings. in hoses. at the gearbox seals, or at the rack-and-pinion assembly.

To check for leaks. wipe the fluid-soaked area(s) with a clean rag. Then have another person start and idle the engine. While watching for leaks, have the steering wheel turned to the right and left. This action will pressurize all components of the system that might be leaking. After locating the leaking component. remove and repair or replace it.

**POWER STEERING PRESSURE TEST.**—A power steering pressure test checks the operation of the power steering pump, the pressure relief valve, the control valve. the hoses. and the power piston. Basic procedures for performing a power steering pressure test are as follows:

Using a steering system pressure tester, connect the pressure gauge and shutoff valve to the power steering pump outlet and hose. Torque the hose fitting properly.

With the system full of fluid, start and idle the engine (with the shutoff valve open) while turning the steering wheel back and forth. This will bring the fluid up to temperature.

Close the shutoff valve to check system pressure. Note and compare the pressure reading with manufacturer's specifications.

### CAUTION

Do NOT close the shutoff valve for more than 5 seconds. If the shutoff valve is closed longer, damage will occur to the power steering pump from overheating.

To check the action of the power piston. control valve. and hoses, measure the system pressure while turning the steering wheel right and left (stop to stop) with the shutoff valve open. Note and compare the readings to the manufacturer's specifications. If the system is not within specifications, use the manufacturer's service manual to determine the source of the problem.

**BLEEDING A POWER STEERING SYSTEM.**—Any time you replace or repair a hydraulic component (pump. hoses, and power piston), you should bleed the system. Bleeding the system assures that all of the air is out of the hoses, the pump, and the gearbox. Air can cause the power steering system to make a BUZZING sound. The sound will occur as the steering wheel is turned right or left.

To bleed out any air, start the engine and turn the steering wheel fully from side to side. Keep checking the fluid and add as needed. This will force the air into the reservoir and out of the system.

## TROUBLESHOOTING STEERING SYSTEMS

The most common problems of a steering system are as follows:

- Steering wheel play
- Hard steering
- Abnormal noises when turning the steering wheel

These problems normally point to component wear, lack of lubrication. or an incorrect adjustment. You must inspect and test the steering system to locate the source of the trouble.

### Steering Wheel Play

The most common of all problems in a steering system is excessive steering wheel play. Steering wheel play is normally caused by worn ball sockets, worn idler arm, or too much clearance in the steering gearbox. Typically, you should not be able to turn the steering wheel more than 1 1/2 inches without causing the front wheels to move. If the steering wheel rotates excessively, a serious steering problem exists.

An effective way to check for play in the steering linkage or rack-and-pinion mechanism is by the dry-park test. With the full weight of the vehicle on the front wheels, have someone move the steering wheel from side to side while you examine the steering system for looseness. Start your inspection at the steering column shaft and work your way to the tie-rod ends. Ensure that the movement of one component causes an equal amount of movement of the adjoining component.

Watch for ball studs that wiggle in their sockets. With a rack-and-pinion steering system, squeeze the rubber boots and feel the inner tie rod to detect wear. If the tie rod moves sideways in relation to the rack, the socket is worn and should be replaced.

Another way of inspecting the steering system involves moving the steering components and front wheel BY HAND. With the steering wheel locked, raise the vehicle and place it on jack stands. Then force the front wheels right and left while checking for component looseness.



## Hard Steering

If hard steering occurs, it is probably due to excessively tight adjustments in the steering gearbox or linkages. Hard steering can also be caused by low or uneven tire pressure, abnormal friction in the steering gearbox, in the linkage, or at the ball joints, or improper wheel or frame alignment.

The failure of power steering in a vehicle causes the steering system to revert to straight mechanical operation, requiring much greater steering force to be applied by the operator. When this happens, the power steering gearbox and pump should be checked as outlined in the manufacturer's service manual.

To check the steering system for excessive friction, raise the front of the vehicle and turn the steering wheel and check the steering system components to locate the source of excessive friction. Disconnect the pitman arm. If this action eliminates the frictional drag, then the friction is in either the linkage or at the steering knuckles. If the friction is NOT eliminated when the pitman arm is disconnected, then the steering gearbox is probably faulty.

If hard steering is not due to excessive friction in the steering system, the most probable causes are incorrect front end alignment, a misaligned frame, or sagging springs. Excessive tire caster causes hard steering. Wheel alignment will be described later in this chapter.

## Steering System Noises

Steering systems, when problems exist, can produce abnormal noises (rattles, squeaks, and squeals). Noises can be signs of worn components, unlubricated bearings or ball joints, loose components, slipping belts, low power steering fluid, or other troubles.

Rattles in the steering linkage may develop if linkage components become loose. Squeaks during turns can develop due to lack of lubrication in the joints or bearings of the steering linkage. This condition can also produce hard steering.

Some of the connections between the steering linkage components are connected by ball sockets that can be lubricated. Some ball sockets are permanently lubricated on original assembly. If permanently lubricated ball sockets develop squeaks or excessive friction, they must be replaced.

Belt squeal is a loud screeching sound produced by belt slippage. A slipping power steering belt will usually show up when turning. Turning the steering wheel to the full right or left will increase system pressure and belt squeal. Belt squeal may be eliminated by either adjusting or replacing the belt.

## REVIEW 3 QUESTIONS

- Q1. What type of steering linkage design is used on most vehicles?*
- Q2. The idler arm supports the pitman arm on the passenger side of the vehicle. (T/F)*
- Q3. What steering linkage component is used to fasten the center link to the steering knuckles?*
- Q4. In a manual steering system, what two factors determine steering ratio?*
- Q5. What is the most common type of worm and nut steering gear?*
- Q6. In a power steering system, what device supplies hydraulic fluid under pressure to the other components in the system?*
- Q7. What are the three major types of power steering systems?*
- Q8. On a manual rack-and-pinion system, what adjustment is required when there is excessive play in the steering?*
- Q9. What is the most common steering problem?*
- Q10. What is the most probable cause(s) of hard steering?*

## TIRES, WHEELS, AND WHEEL BEARINGS

**Learning Objective:** Identify and describe the parts of a tire and the methods of tire construction. Explain tire and wheel sizes. Describe tire ratings and the different types of wheels. Identify the parts of driving and nondriving hubs and wheel-bearing assemblies. Diagnose common tire, wheel, and wheel-bearing problems. Describe tire inflation and rotation procedures. Explain static and dynamic wheel balance. Summarize the different methods for balancing tires and wheels. Explain wheel-bearing service.

This section introduces the various tire designs used on modern vehicles. It explains how tires and wheels are constructed to give safe and dependable service. This section also covers hub and

wheel-bearing construction for both rear-wheel and front-wheel drives.

## TIRE CONSTRUCTION

Most modern passenger vehicles and light trucks use tubeless tires that do NOT have a separate inner tube. The tire and wheel form an airtight unit. Many commercial and construction vehicles use inner tubes which are a soft, thin, leakproof rubber liner that fit inside the tire and wheel assemblies. However, in the last few years tubeless tires have been introduced to commercial and construction vehicles, reducing the need for tube type tires. Tires perform the following two basic functions:

- They must act as a soft CUSHION between the road and the metal wheel.
- They must provide adequate TRACTION (friction) with the road surface.

Tires must transmit driving, braking, and cornering forces to the road in all types of weather. At the same time, they should resist puncture and wear. Although there are several tire designs, the six major parts of a tire are as follows:

- TIRE BEADS (two steel rings encased in rubber that holds the tire sidewalls against the wheel rim).
- BODY PLYS (rubberized fabric and cords wrapped around beads, forming the carcass or body of the tire).
- TREAD (outer surface of the tire that contacts the road surface).
- SIDEWALL (outer surface of the tire extending bead to tread; it contains tire information).
- BELTS (used to stiffen the tread and strengthen the plies; they lie between the tread and the inner plies).
- LINER (a thin layer of rubber bonded to the inside of the plies; it provides a leakproof membrane for tubeless tires).

There are many construction and design variations in tires. A different number of plies may be used and ran at different angles. Also, many different materials may be used. The three types of tires, found on late model vehicles, are bias-ply, belted bias, and radial.

### Bias-Ply Tire

A bias-ply tire is one of the oldest designs, and it does NOT use belts. The position of the cords in a

bias-ply tire allows the body of the tire to flex easily. This design improves the cushioning action, which provides a smooth ride on rough roads.

A bias-ply tire (fig. 8-29) has the plies running at an angle from bead to bead. The cord angle is also reversed from ply to ply, forming a crisscross pattern. The tread is bonded directly to the top ply.

A major disadvantage of a bias-ply tire is that the weakness of the plies and tread reduce traction at high speeds and increase rolling resistance.

### Belted Bias Tire

A belted bias tire provides a smooth ride, good traction, and offers some reduction in rolling resistance over a bias-ply tire. The belted bias tire is a bias-ply tire with stabilizer belts added to increase tread stiffness. The belts and plies run at different angles. The belts do NOT run around to the sidewalls but lie only under the tread area. Two stabilizer belts and two or more plies are used to increase tire performance.

### Radial Ply Tire

The radial ply tire (fig. 8-30) has very flexible sidewall, but a stiff tread. This design provides for a very stable footprint (shape and amount of tread touching the road surface) which improves safety, cornering, braking, and wear. The radial ply tire has plies running straight across from bead to bead with stabilizer belts directly beneath the tread. The belts can be made of steel, flexten, fiber glass, or other materials.

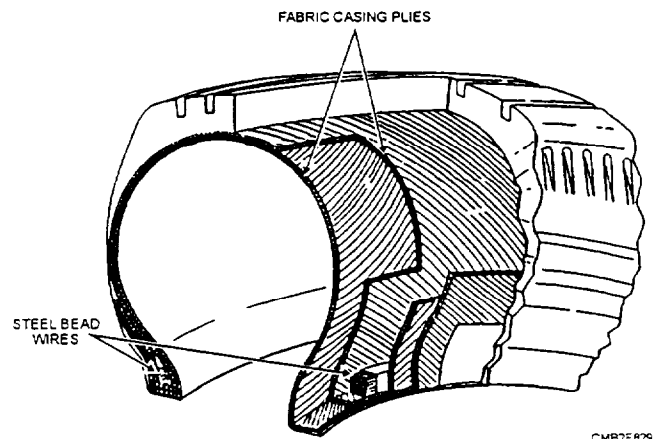

Figures 8-29.—Bias-ply tire construction.

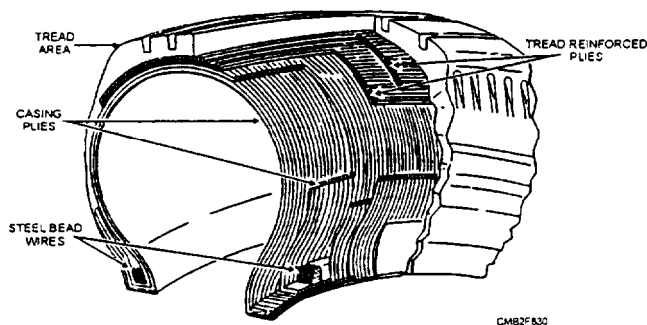

Figure 8-30.—Radial tire construction.

A major disadvantage of the radial ply tire is that it produces a harder ride at low speeds. The stiff tread does NOT give or flex as much on rough road surfaces.

### TIRE MARKINGS

There is important information on the sidewall of a tire. Typically, you'll find UTQG (Uniform Tire Quality Grading) ratings for treadwear, traction, and temperature. Also, you will also find the tire size, load index and speed rating, and inflation pressure. It is important that you understand these tire markings.

### Tire Size

Tire size on the sidewall of a tire is given in a letter-number sequence. There are two common size

designations (fig. 8-31)—alphanumeric (conventional measuring system) and P-metric (metric measuring system).

The alphanumeric tire size rating system, as shown in figure 8-31, uses letters and numbers to denote tire size in inches and load-carrying capacity in pounds. The letter *G* indicates the load and size relationship. The higher the letter the larger the size and load-carrying capability. The letter *R* designates the radial design of the tire. The first number "78" is the aspect ratio, also known as height-to-width ratio. The last number "15" is the rim diameter in inches.

The P-metric tire size identification system, as shown in figure 8-31, uses metric values and international standards. The letter *P* indicates a passenger vehicle (*T* means temporary and *C* means commercial). The first number "155" indicates the section width in millimeters measured from sidewall to sidewall. The second number "80" is the aspect ratio, also known as height-to-width ratio. The letter *R* indicates radial (*B* means bias belted, *D* means bias-ply construction).

### NOTE

Truck tires are sometimes marked with the designation *LT* for "light truck" before the size.

The ASPECT RATIO or height-to-width ratio in the tire size is the most difficult value to understand. Aspect ratio is the comparison of the height of a tire

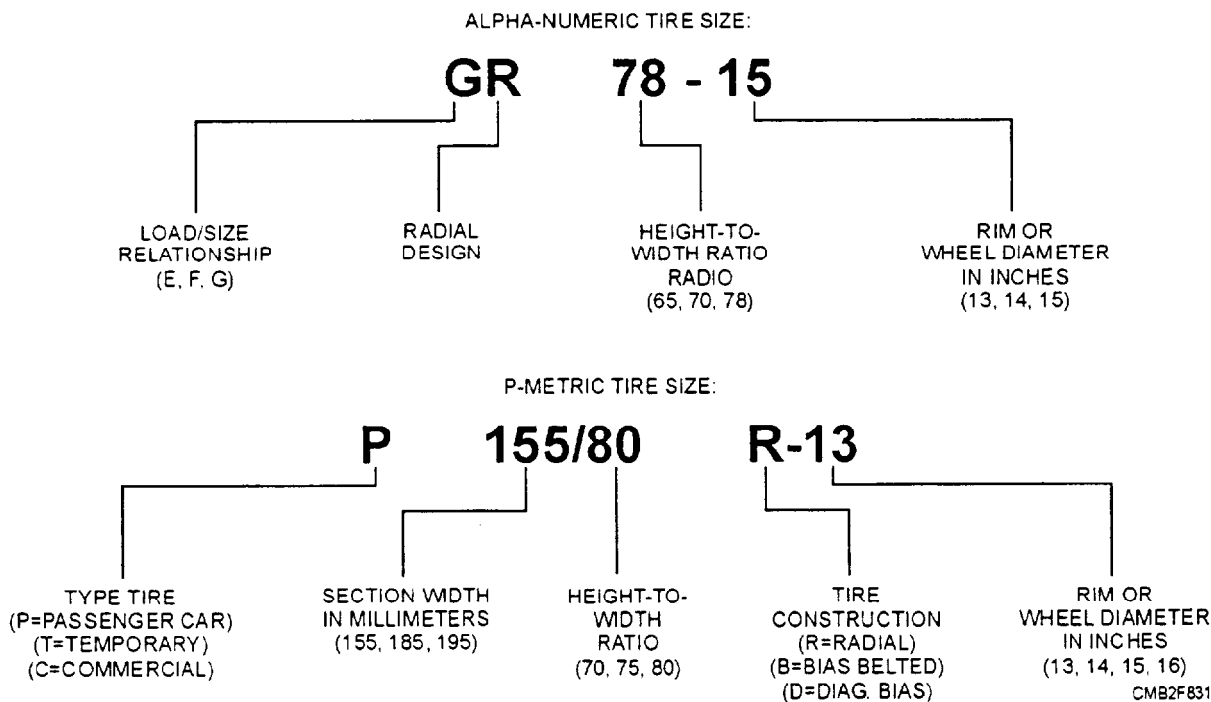

Figure 8-31.—Tire size designation numbering systems.

(bead to tread) to the width of a tire (sidewall to sidewall). It is height divided by width. A 80-series tire, for example, has a section height that is 80 percent of the section width.

As the aspect ratio becomes smaller, the tire becomes more squat (wider and shorter). A 60-series tire would be "short" and "fat." whereas an 80-series tire would be "narrower" and "taller."

### Load Index and Speed Rating

The term *load index*, or *load range*, is used to identify a given size tire with its load and inflation limits when used in a specific type of service. The load index of a tire and proper inflation pressure determines how much of a load the tire can carry safely.

A letter identifies the load index for most light trucks. These letters being *B*, *C*, or *D*. A tire with a *B* load rate is restricted to a load specified at 32 psi. Where a greater load-carrying ability is required, load rate *C* or *D* tires are used.

Passenger vehicle tires come with a service description added to the end of the tire size. These service descriptions contain a number, which is the load index, and a letter, which indicates the speed rating. The load index (fig. 8-32) represents the maximum load each tire is designed to support. Because the maximum tire load capacity is branded on

LOAD INDEX & LOAD IN LBS.			
LOAD INDEX	LOAD (lbs*)	LOAD INDEX	LOAD (lbs *)
65	639	85	1135
66	661	86	1168
67	677	87	1201
68	694	88	1235
69	716	89	1279
70	739	90	1323
71	761	91	1356
72	783	92	1389
73	805	93	1433
74	827	94	1477
75	852	95	1521
76	882	96	1565
77	908	97	1609
78	937	98	1653
79	963	99	1709
80	992	100	1764
81	1019	101	1819
82	1047	102	1874
83	1074	103	1929
84	1102	104	1984

CMB2F832  
Figure 8-32.—Load index chart for a passenger vehicle.

the sidewall of the tire, the load rate is used as a quick reference. Speed ratings (fig. 8-33) signify the safe top speed of a tire under PERFECT conditions.

### Maximum Inflation Pressure

The maximum inflation pressure, printed on the sidewall of a tire, is the highest air pressure that should be induced into the tire. The tire pressure is a "cold" pressure and should be checked in the morning before operating the vehicle.

In most parts of the world, fall and early winter months are the most critical times to check inflation pressures because the days are getting colder. And since air is a gas, it contracts when cooled. For every 10°F change in ambient temperature, the inflation pressure of a tire will change by 1 psi. It will go down with lower temperatures and up with higher temperatures. The typical difference between summer and winter temperatures is about 50°F that results in a loss of 5 psi and will sacrifice handling, traction, durability, and safety.

### Tire Grades

The Department of Transportation requires each manufacturer to grade its tires under the Uniform Tire Quality Grade (UTQG) labeling system and

SPEED RATING SYMBOL		
RATING SYMBOL	SPEED (KM/H)	RATING (MPH)
B	50	31
C	50	37
D	55	40
E	70	43
F	80	50
G	90	56
J	100	62
K	110	68
L	120	75
M	130	81
N	140	87
P	150	93
Q	160	99
R	170	106
S	180	112
T	190	118
U	200	124
H	210	130
V	240	150
W	270	169
Y	300	188
ZR	OVER 240	OVER 150

CMB2F833  
Figure 8-33.—Speed rating chart for a passenger vehicle.

establishes ratings for treadwear, traction, and temperature resistance (fig. 8-34). These tests are conducted independently by each manufacturer following government guidelines to assign values that represent a comparison between the tested tire and a control tire. While traction and temperature resistance ratings are specific performance levels, the treadwear ratings are assigned by the manufacturers following field-testing and are most accurate when comparing tires of the same brand. Tire grades are as follows:

- **TREADWEAR**—Treadwear receives a comparative rating based on wear rate of the tire in field-testing following a government-specified course. Treadwear is given as a number: 100, 120, or 130, for instance. The higher the number, the more resistant the tire is to wear. For example, a tire grade of 150 wears 1.5 times longer than a tire graded 100. Actual performance of the tire will vary significantly depending on conditions, driving habits, care, road characteristics, and climate.

- **TRACTION**—Straight-a-head wet braking traction has been represented by a grade of A, B, or C with A being the highest. In 1997 a new top rating of "AA" was introduced to indicate even greater wet braking traction. Traction grades do NOT indicate wet cornering ability.

- **TEMPERATURE**—Temperature resistance is grades A, B, or C. This represents the resistance of the tire to heat generated by running at high speed. Grade C is the minimum level of performance for all passenger vehicle tires as set under Federal Motor Vehicle Safety Standards. This grade is established for a tire that is properly inflated and not overloaded.

#### NOTE

Uniform Tire Quality Grade ratings are NOT required on winter, light truck, and commercial tires.

#### TUBES

Tubes (inner tubes) are circular rubber containers that fit inside the tire and hold the air that supports the

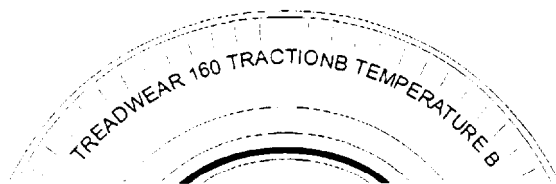

Figure 8-34.—Uniform Tire Quality Grade System ratings on the sidewall of a tire.

vehicle. Though it is strong enough to hold only a few pounds of air when not confined, the tube bears extremely high pressures when enclosed in a tire and wheel assembly. Because the tube is made of comparatively soft rubber to fulfill its function, it is easily chafed, pinched, punctured, or otherwise damaged. Tubes generally are made of a synthetic rubber that has air-retention properties superior to natural rubber. There are two types of synthetic rubber tubes—butyl and GR-S. A butyl type tube is identified by a blue stripe, and GR-S has a red stripe. Other than the standard tube, there are three special types of tubes—radial tire, puncture sealing, and safety.

- **RADIAL-TIRE TUBE**—The construction of an inner tube for use in a radial tire differs from the tube used in a bias tire. A radial tire flexes in such a manner that it concentrates the flex action in one area and at the edge of the belts in the shoulder of the tire. This concentration of stress will damage a standard tube causing it to fail. To overcome this problem, the radial tube is made of a special rubber compound that is designed to overcome this concentrated stress; Therefore, standard tubes must NEVER be used in radial tires.

- **PUNCTURE-SEALING TUBE**—This type of tube has a coating of plastic material in the inner surface. When the tube is punctured, this plastic material is forced into the puncture by the internal air pressure. The plastic material then hardens, sealing the puncture.

- **SAFETY TUBE**—The safety tube is really two tubes in one, one smaller than the other, and joined at the rim edge. When the tube is filled with air, the air flows first into the inside tube. From there the air passes through an, equalizing passage into space between the two tubes. Therefore, both tubes are filled with air. If a puncture occurs, air is lost from between the tubes. However, the inside tube, which has not been damaged, retains its air pressure. It is sufficiently strong enough to support the weight of the vehicle until the vehicle can be slowed and stopped. Usually, the inside tube is reinforced with nylon fabric. The nylon fabric takes the suddenly imposed weight of the vehicle, without giving way, when a blowout occurs.

#### WHEELS

Wheels must have enough strength to carry the weight of the vehicle and withstand a wide range of speed and road conditions. Automobiles and light trucks are equipped with a single piece wheel. Larger vehicles have a lock ring (side ring) that allows for the

easy removal of the tire from the wheel and, when in place, it provides a seat for one side of the inflated tire.

A standard wheel consists of the RIM (outer lip that contacts the bead) and the SPIDER (center section that bolts to the vehicle hub). Normally the spider is welded to the rim. Common wheel designs are as follows:

- Drop center
- Semidrop center
- Safety
- Split

### Drop Center Wheel

The drop center wheel (fig. 8-35) is made in one piece and is commonly used on passenger vehicles because it allows for easier installation and removal of the tire. Bead seats are tapered to match a corresponding taper on the beads of the tire.

### Semidrop Center Wheel

The semidrop center wheel (fig. 8-36) has a shallow well, tapered-head seat to fit the taper of the beads of the tire. It also has a demountable flange or side ring, which fits into a gutter on the outside of the rim, holding the tire in place.

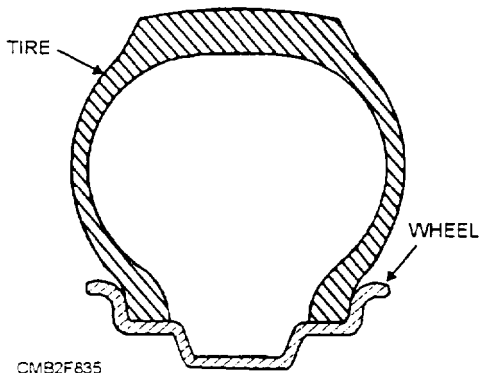

Figure 8-35.—Drop center wheel.

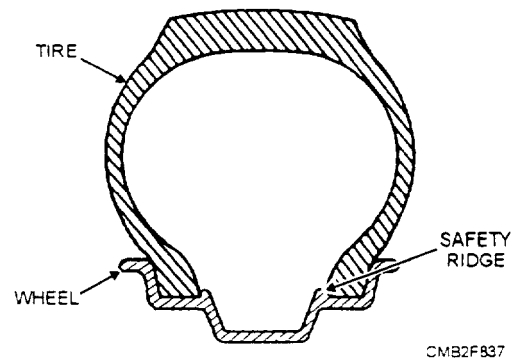

Figure 8-37.—Safety wheel.

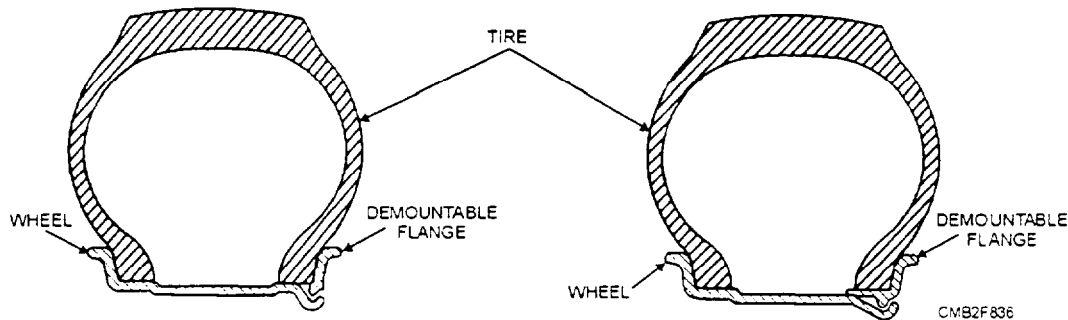

Figure 8-36.—Semidrop center wheel.

### Safety Wheel

A safety wheel (fig. 8-37) is similar to the drop center wheel. The major difference is that the safety wheel has a slight hump at the edge of the bead ledge that holds the bead in place when the tire goes flat.

### Split Wheel

A split wheel (rim) (fig. 8-38) has a removable bead seat on one side of the rim. The seat is split to allow for its removal so tires can be easily changed. Some bead seats also require the use of a lock ring to retain the seat. These wheels are used on large commercial and military vehicles.

### LUG NUTS, STUDS, AND BOLTS

Lug nuts hold the wheel and tire assembly on the vehicle. They fasten onto special studs. The inner face of the lug nut is tapered to help center the wheel on the hub. Lug studs are special studs that accept the lug nuts. The studs are pressed through the back of the hub or axle flange. A few vehicles use lug bolts instead of nuts. The bolts screw into threaded holes in the hub or axle flange.

Normally, the lug nuts and studs have right-hand threads (turn clockwise to tighten). When left-hand threads are used, the nut or stud will be marked with an "L." Metric threads will be identified with the letter *M* or the word *Metric*.

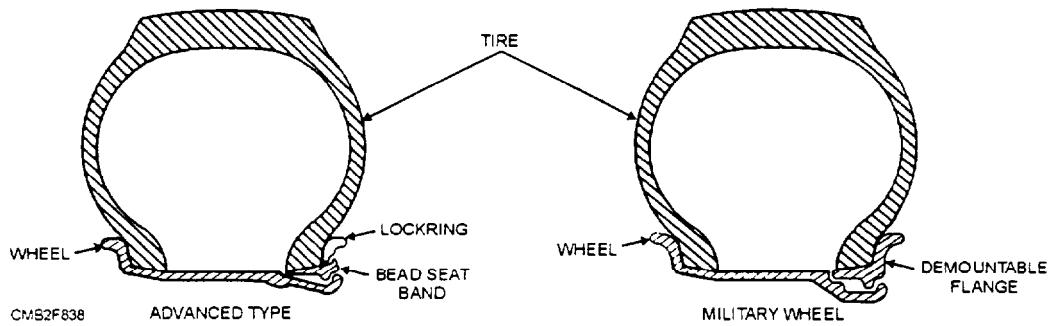

Figure 8-38.—Split wheel.

## WHEEL BEARING AND HUB ASSEMBLY

Wheel bearings allow the wheel and tire assembly to turn freely around the spindle, in the steering knuckle, or in the bearing support. Wheel bearings are lubricated with heavy, high-temperature grease. This allows the bearing to operate with very little friction and wear.

The two basic wheel-bearing configurations are tapered roller or ball bearing types. The basic parts of a wheel bearing are as follows:

- OUTER RACE (cup or cone pressed into the hub, steering knuckle, or bearing support)
- BALLS or ROLLERS (antifriction elements that fit between the inner and outer races)
- INNER RACE (cup or cone that rests on the spindle or drive axle shaft)

There are two types of wheel bearing and hub assemblies—nondriving and driving. For example, the front wheels on a rear-wheel drive vehicle are nondriving.

### Nondriving Wheel Assembly

The components of a nondriving wheel bearing and hub assembly (fig. 8-39) includes the following:

- SPINDLE—a stationary shaft extending outward from the steering knuckle or suspension system to which the following components are attached.
- WHEEL BEARINGS—normally tapered roller bearings mounted on the spindle and in the wheel hub.
- HUB—outer housing that holds the brake disc, or drum, wheel, grease, and wheel bearing.
- GREASE WHEEL—a seal that prevents loss of lubricant from the inner end of the spindle and hub.
- SAFETY WASHER—a flat washer that keeps the outer wheel bearing from rubbing on and possibly turning the adjusting nut.
- SPINDLE ADJUSTING NUT—a nut threaded on the end of the spindle for adjusting the wheel bearing.
- NUT LOCK—a thin, slotted nut that fits over the main spindle nut.
- DUST CAP—a metal cap that fits over the outer end of the hub to keep grease in and dirt out of the bearings.

Since a nondriving wheel bearing and hub assembly does NOT transfer driving power, the

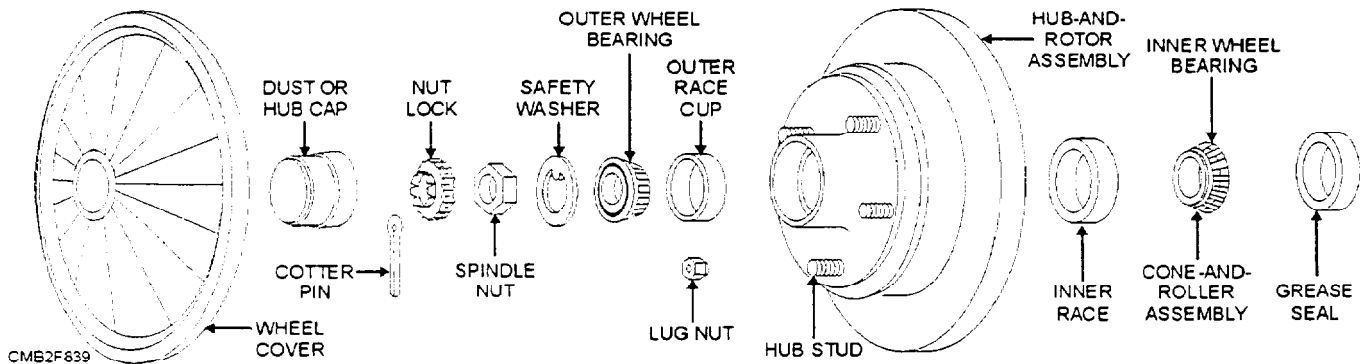

Figure 8-39.—Disassembled view of a nondriving wheel bearing and hub assembly.

spindle is stationary. The spindle simply extends outward and provides a mounting surface for the wheel bearings, hub, and wheel. With the vehicle moving, the wheel and hub spin on the wheel bearings and spindle. The hub simply freewheels.

### Driving Wheel Assembly

The components of a driving wheel bearing and hub assembly (fig. 8-40) includes the following:

- **OUTER DRIVE AXLE**—a stub axle shaft that extends through the wheel bearings and is splined to the hub.
- **WHEEL BEARINGS**—either ball or roller type bearings that allow the drive axle to turn in the steering knuckle or bearing support.
- **STEERING KNUCKLE or BEARING SUPPORT**—a suspension or steering component that holds the wheel bearings, axle stub, and hub.
- **DRIVE HUB**—a mounting place for the wheel which transfers driving power from the stub axle to the wheel.
- **AXLE WASHER**—a special washer that fits between the hub and locknut.
- **HUB or AXLE LOCKNUT**—a special nut that screws onto the end of the drive axle stub shaft to secure the hub and other parts of the assembly.
- **GREASE SEAL**—prevents lubricant loss between the inside of the axle and the steering knuckle and bearing support.

The driving wheel bearing and hub assembly has bearings mounted in a stationary steering knuckle or bearing support. The drive axle fits through the center of the bearings. The hub is splined to the axle shaft. Instead of a stationary spindle, the axle shaft spins

inside the stationary support. With the hub splined to the axle shaft, power is transferred to the wheels.

### TIRE REPAIR

Leaks from a tubeless tire are located by filling the tire with air and then placing the tire in a drum full of water. Bubbles will show the location of any leaks. If a drum of water is not available, coat the tire with soapy water. Soap bubbles will show the location of the leak.

It has been common practice to attempt the repair of some punctures without dismounting the tire through the use of a rubber plug. However, this practice is **NO LONGER RECOMMENDED**, because of serious safety concerns. Using a plug to attempt tire repair without dismounting is effective only 80 percent of the time. The remaining 20 percent of such repairs will result in **TIRE FAILURE**, which may take the form of a dangerous sudden deflation (blowout).

The safe and correct procedure for tire repair is to **ALWAYS** remove the tire from the wheel and make the repairs from the inside of the tire. After the tire has been dismounted, it should be thoroughly **INSPECTED**. During this inspection, check the inside surface carefully, to locate the puncture and determine the nature and extent of the damage.

The Rubber Manufacturer's of America list two requirements for correctly repairing a puncture—the repair **MUST** fill the injury to the tire and the repair **MUST** soundly patch the inner liner. Various products are available for repairing the puncture to the tire, including plugs and liquid sealants.

The basic procedures for repairing a tubeless tire are as follows:

- Select a patch of sufficient size to extend well beyond the damaged area, so it will adhere properly and withstand the heat and mechanical stress of the tire.

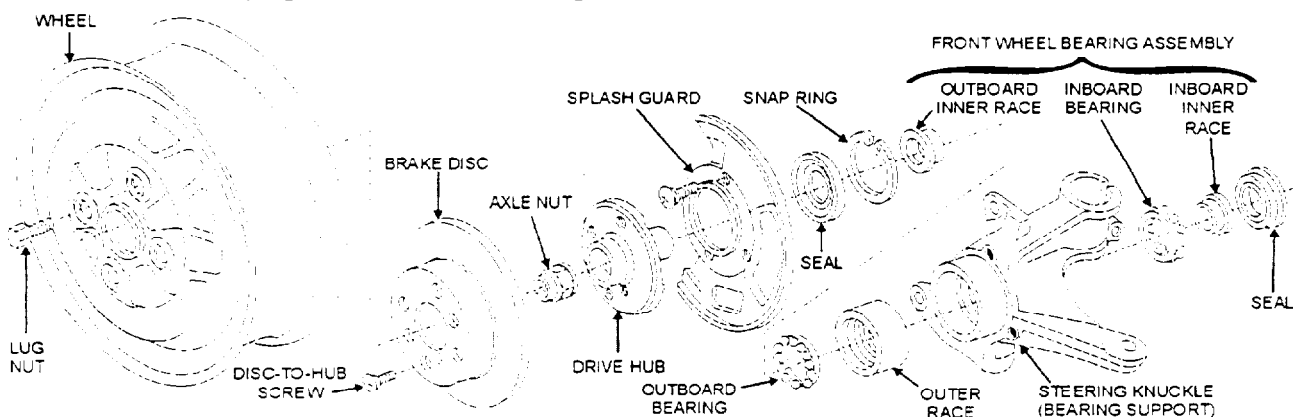

Figure 8-40.—Disassembled view of a driving wheel bearing and hub assembly.



- Scuff (roughen) the area that the patch will cover, so it will adhere tightly.
- Apply the proper cement (adhesive), following the directions in the tire repair kit.
- Remove the covering from the adhesive side of the patch and carefully place it on the inner liner.
- Using a tool, called a sticher, roll it across the patch to bond the patch tightly to the inner liner.
- A few basic safety rules for repairing a tubeless tire are as follows:
- Do NOT attempt to repair a puncture by plugging the tire from the outside. ALWAYS dismount the tire and patch the inner liner.
- Do NOT attempt to repair sidewalls or tires with punctures larger than a 1/2 inch.
- Reduce the air pressure to at least 15-psi, when removing an object from the tire.
- Broken strands in a steel belted tire can indicate more serious damage than initially suspected. Replace the tire.
- Follow the procedures given in the tire repair kit.

## TUBE REPAIR

If a tube tire has been punctured but has no other damage, it can be repaired with a patch. Remove the tube from the tire to find the leak. Inflate the tube and then submerge it in water. Bubbles will appear where there is a leak. Mark the spot. Then deflate and dry the tube.

There are two methods to patch a tube leak. They are the cold-patch method and the hot-patch method. With the cold-patch method (also known as chemical vulcanizing), first make sure the area is clean, dry, and free of grease and oil. Scuff the area around the leak. Then cover the area with vulcanizing cement. Let the cement dry until tacky. Press the patch into place. Roll it from the center out with a "stitching tool" or the edge of the patch kit can.

With the hot-patch method, prepare the tube in the same way as for the cold patch. Put the hot patch into place and clamp it. Then, with a match, light the fuel on the back of the patch. As the fuel burns, the heat vulcanizes the patch to the tube. After the patch has cooled, inflate the tube and recheck for leaks by submerging the tube in water. Another kind of hot patch uses a vulcanizing hot plate. The hot plate supplies the heat required to bond the patch to the tube.

## PREVENTIVE MAINTENANCE

Preventive maintenance of tires and wheels involves periodic inspections, checking inflation pressure, wheel balancing, and rotation. Wheel bearings are periodically lubricated and checked for wear. These preventive maintenance steps will help assure vehicle safety and a longer component life.

### Rotating Tires

Tire rotation can be beneficial in several ways. When done at the recommended times, it can preserve balanced handling and traction of the tires and even out tire wear. It can even provide performance advantages. Manufacturers recommend that tires be rotated every 3,000 to 5,000 miles, even if they do not show signs of wear. Tire rotation when done at the recommended times helps even out tire wear by allowing each tire to serve in as many of the wheel positions of the vehicle as possible.

### NOTE

Remember that tire rotation can NOT correct problems due to worn mechanical parts or incorrect inflation pressures.

While every vehicle is equipped with four tires, usually tires on the front need to accomplish very different tasks than the rear tires. And the tasks encountered on a front-wheel drive vehicle are considerably different than those of a rear-wheel drive vehicle. Each wheel position can cause different wear rates and different types of tire wear. It is to your advantage when all four tires wear together because as wear reduces tread depth of a tire, it allows tires to respond to the operator's input more quickly, maintains the handling, and it helps increase the cornering traction of a tire. Figure 8-41 shows common tire rotation diagrams. A description of each is as follows.

- On front-wheel drive vehicles, rotate the tires in a forward cross pattern (A) or the alternative X pattern (B).
- On rear-wheel drive vehicles, rotate the tires in a rearward cross pattern (C) or the alternative X pattern (B).
- If the vehicle has directional tires, rotate these tires from front to back only and vice versa(D).
- If the vehicle has nondirectional tires that are a different size from front to rear, rotate these tires from side to side only (E).

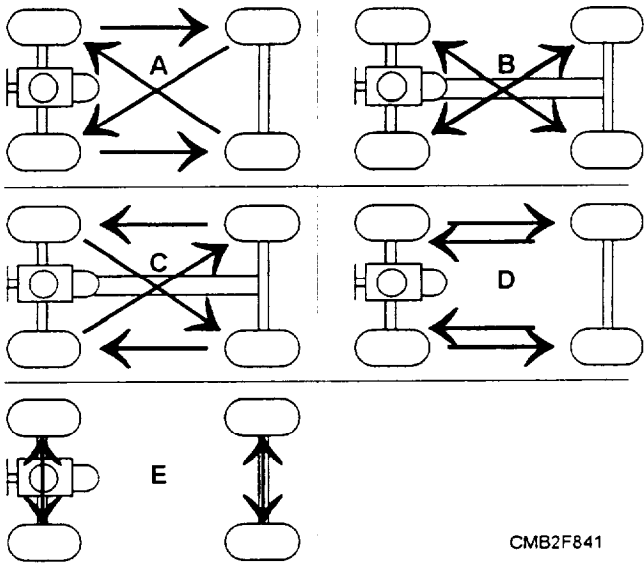

Figure 8-41.—Tire rotation diagrams.

When your tires wear out together, you can get a new set of tires without being forced to change tires in pairs. By replacing tires as sets, you will maintain the original handling balance.

### Wheel Balancing

Improper wheel balance is the most common cause of tire vibration. Often a tire will appear to be round and true when rotated slowly. However, when one side is heavier than the other, centrifugal force tries to throw the heavy area outward during operation. To obtain maximum tire wear and a comfortable ride, you should balance the wheels. The two types of tire imbalance are as follows:

- **DYNAMIC IMBALANCE** (fig. 8-42) lies on either or both sides of the center line of the tire, which causes the tire to vibrate up and down (wheel hop) and from side to side (wheel shimmy). To be in dynamic balance, the top-to-bottom weight and the side-to-side weight must all be equal.
- **STATIC IMBALANCE** (fig. 8-43), also called wheel tramp or hop, lies in the plane of wheel rotation, which causes the tire to vibrate up and down. For a wheel and tire assembly to be in static balance, the weight must be evenly distributed around the axis of rotation.

To static balance a wheel and tire assembly, add wheel weights opposite the heavy area of the wheel. If a large amount of weight is needed, add half to the outside and the other half to the inside of the wheel. This will keep the dynamic balance of the tire. However, when dynamically balancing a wheel and

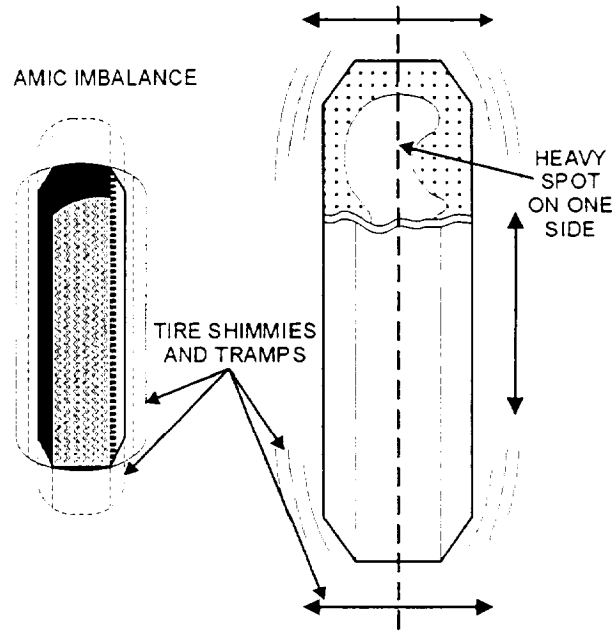

Figure 8-42.—Dynamic imbalance.

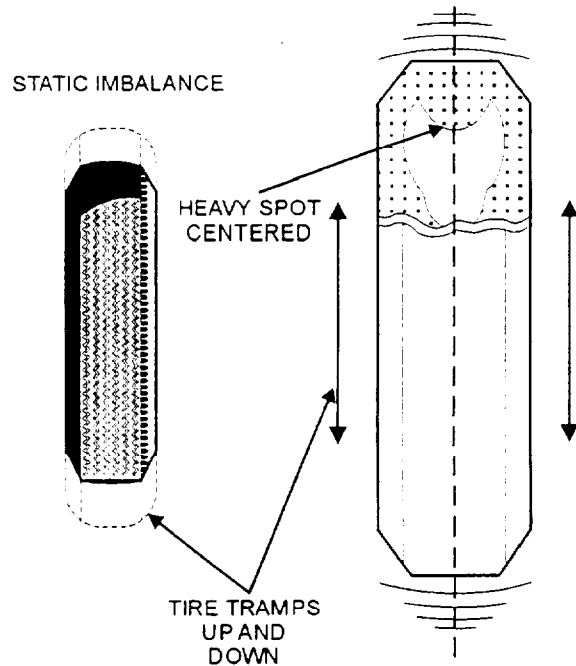
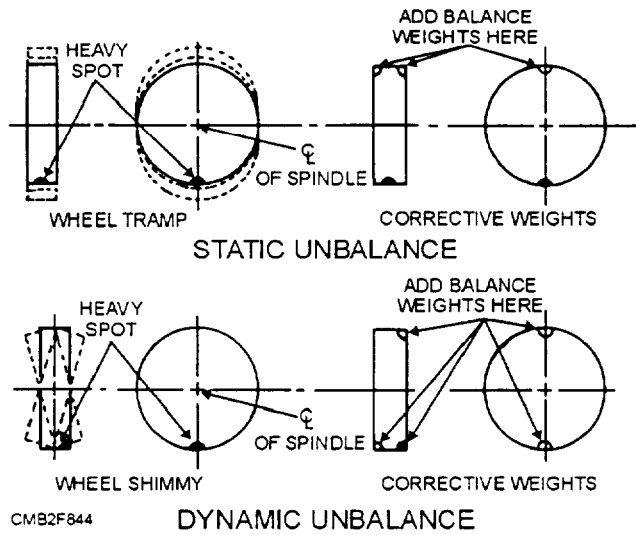

Figure 8-43.—Static imbalance.

tire assembly, the weights must be added exactly where needed (fig. 8-44).

A wheel-balancing machine is used to determine which part of a wheel assembly is heavy. The three types of balancing machines are as follows:

- **BUBBLE BALANCER** (fig. 8-45) is the most common type of balancer used by the NCF. This type of balancer will ONLY statically balance a wheel



CMB2F844

Figure 8-44.—How weights should be placed when balancing tires.

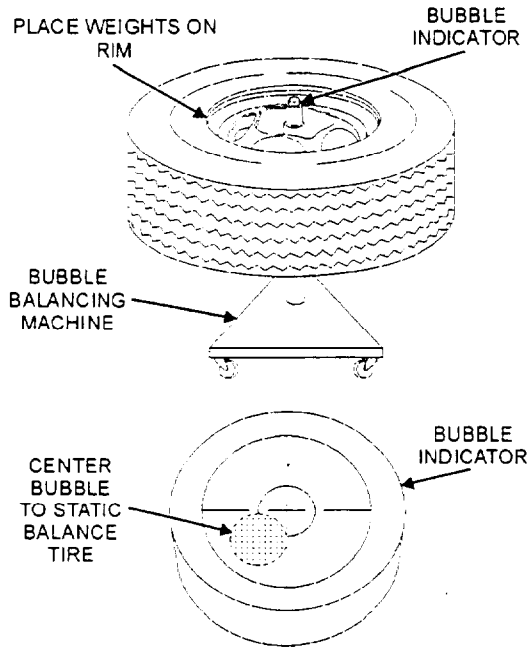

CMB2F845

Figure 8-45.—Bubble balancer.

assembly. The wheel assembly must be removed from the vehicle and placed on the balancer. An indicating bubble on the machine is used to locate the heavy area of the assembly. Wheel weights are added to the assembly until the bubble **CENTERS** on the crosshairs of the machine.

- **OFF-THE-VEHICLE BALANCER** (spin balancer) can statically and dynamically balance a wheel assembly. The wheel assembly is removed from the vehicle and mounted on the balancer. The assembly is then spun at a high rate of speed. The machine detects any vibration of the assembly and indicates where the

wheel weights are to be added. After the weights are added to the assembly, spin the assembly to again check for vibration.

- **ON-THE-VEHICLE BALANCER** (spin balancer) (fig. 8-46) is also used to balance a tire statically and dynamically. An electric motor is used to spin the wheel assembly and either a electronic pick-up unit or hand-operated device is used to determine the location for the wheel weights. An on-the-vehicle type balancer is desirable because it can balance not only the wheel assembly, but the wheel cover, brake disc or drum, and lug nuts. Everything is rotated as a unit.

### Wheel-Bearing Service

Wheel bearings are normally filled with grease. If this grease dries out, the bearing will fail. Some wheel bearings can be disassembled and packed (filled) with grease, while others are sealed units that require replacement when worn. When performing tire-related service, check the wheel bearings for play and wear.

### NOTE

For procedures on checking, removing, and replacing wheel bearings, refer to the manufacturer's service manual.

### TROUBLESHOOTING

Tire problems usually show up as vibrations, abnormal wear patterns, abnormal noises, steering wheel pull, and other similar symptoms. In some cases, you may need to operate the vehicle to verify the problem. Make sure that symptoms are **NOT** being caused by steering, suspension, or front-wheel alignment problems.

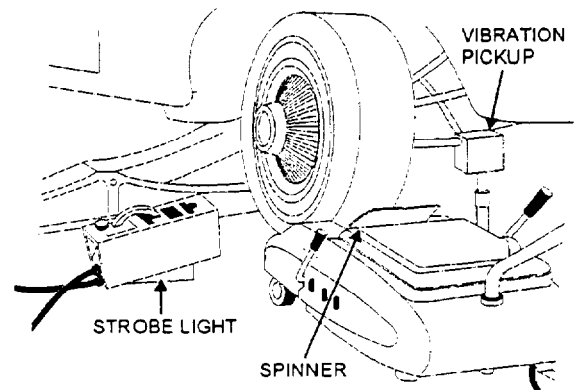

CMB2F846

Figure 8-46.—On-the-vehicle balancer.

When inspecting tires, you should look closely at the outer sidewall, tread area, and inner sidewall for bulges, splits, cracks, chunking, cupping, and other abnormal wear or damage. If problems are found before repairing or replacing the tire, determine what caused the failure.

### Tire Impact Damage

Tire impact damage or road damage includes tears, punctures, cuts, and other physical injuries. Depending upon the severity of the damage, the tire must either be repaired or replaced.

### Tire Wear Patterns

Tire wear patterns can be studied to determine the cause of abnormal tread wear. By inspecting the tread wear, you can determine what parts should be serviced, repaired, or replaced. Common tread wear patterns are as follows (fig. 8-47):

- **FEATHERING (A)** is caused by erratic scrubbing against the surface of the road when the tire is in need of toe-in or toe-out alignment correction.
- **OVERINFLATION (B)** causes fast center line wear in bias and bias belted tires. In this case, the center of the tread has more contact with the road and wears faster than the outer area of the tread.
- **UNDERINFLATION (C)** causes the outer tread areas (shoulders) of the tire to have more contact with the road; therefore, they wear faster than the center area of the tread.
- **ONE-SIDE WEAR (D)** is caused by excessive camber, which means that the tire is leaning too much to the inside or outside. This places all the work on one side of the tire, resulting in excessive wear.
- **CUPPING (E)** is caused by several problems, such as imbalanced wheels, faulty shock absorbers, faulty ball joints, or a combination of these troubles.

### Tire Inflation Problems

The correct tire inflation pressure is important to the service life of the tire. Proper inflation is required to ensure that the tread of the tire fully contacts the road surface. This condition allows for even wear across the tread, therefore, resulting in increased tire life and improved handling and safety.

Tire overinflation causes the center area of the tread to wear quickly. The high pressure causes the

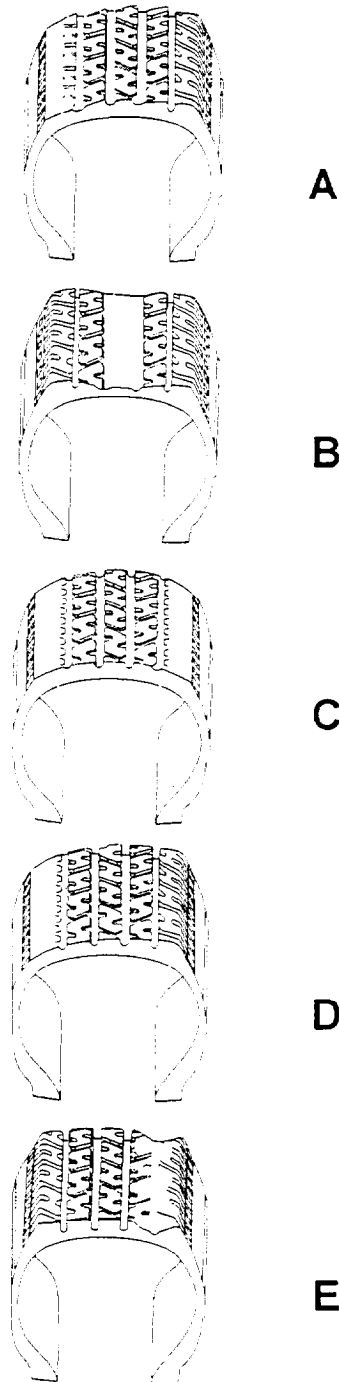

CMB2F847

Figure 8-47.—Tread wear patterns.

body of the tire to stretch outward, pushing the center of the tread against the road surface. This action lifts the outer edges of the tread OFF the road. An overinflated tire produces a rough or hard ride. It is also more prone to impact damage.

Tire underinflation is a very common and destructive problem. This condition wears the outer edges of the tread (shoulders) because low pressure allows the sidewalls of the tire to flex which builds up

heat during operation. The center of the tread flexes upward and does NOT touch the surface of the road. Underinflation will cause rapid tread wear, loss of fuel economy, and possibly ply separation (plies tear away from each other).

Uneven tire inflation pressure can cause steering wheel pull. For example, when a vehicle that has the left front tire underinflated and the right front tire properly inflated, the vehicle has a tendency to pull to the left. The low air pressure in the left tire has more rolling resistance. This action tends to pull the steering wheel away from the normally inflated tire.

### **Tire Vibration Problems**

When one of the front tires is vibrating, it can be felt in the steering wheel. When one of the rear tires is vibrating, the vibration can be felt in the center and rear of the vehicle. Tire vibration can be attributed to several problems, such as out-of-balance condition, ply separation, tire runout, a bent wheel, or tie cupping.

### **Tire and Wheel-Bearing Noise**

Tire noise usually shows up as a whine due to abnormal tread wear or a thumping sound caused by ply separation. Tire replacement is required to correct these problems.

Wheel-bearing noise is produced by dry, worn wheel bearings. The bearing will make a steady humming type sound. This is due to the rollers or balls being damaged from lack of lubrication and are no longer smooth. To check for a worn wheel bearing, raise and secure the vehicle, and rotate the tire by hand. Feel and listen carefully for bearing roughness. Also, wiggle the tire back and forth to check for bearing looseness. It may be necessary to disassemble the wheel bearing to verify the problem.

### **REVIEW 4 QUESTIONS**

- Q1. What are the two basic functions of a tire?*
- Q2. List the six major parts of a tire.*
- Q3. What is the major disadvantage of a radial tire?*
- Q4. What information is commonly given on the tire sidewall?*
- Q5. What is the most commonly used wheel used on passenger vehicles?*
- Q6. What are the two basic wheel-bearing configurations?*

- Q7. For a tire to be in dynamic balance, the weight must be evenly distributed around the axis of rotation. (T/F)*

### **WHEEL ALIGNMENT**

Learning Objective: State the purpose and describe each wheel alignment setting. Describe the different types of equipment used during wheel alignment service.

The term *alignment* means to position in a straight line. Relating to vehicles, alignment means to position the tires so they roll freely and evenly over the road surface. The main purpose of wheel alignment is to make the tires roll without scuffing, slipping, or dragging under all operating conditions. Correct wheel alignment is essential to vehicle safety, handling, extending tire life, and achieving maximum fuel economy.

The different types of wheel alignments are front end alignment, thrust angle alignment, and four-wheel alignment.

1. In a front end alignment, the front only is checked. This is fine in some cases, but are the front tires properly positioned in front of the rear tires?

2. With the thrust angle alignment, the wheels are squared to each other. This action will eliminate “dog tracking” that you may have seen on a vehicle that appears to be going down the road with the rear end a foot over from the front.

3. The best way to align a vehicle is a four-wheel alignment. This alignment will not only do what the thrust angle alignment does but also includes adjusting the settings on the rear of the vehicle as well as the front.

Not all vehicles are fully adjustable, so before any alignment always consult the manufacturer's service manual. Regular wheel alignments will save you as much in tire wear as they cost. It should be considered routine, preventive maintenance.

### **STEERING GEOMETRY**

*Steering geometry* is the term manufacturers use to describe steering and wheel alignment. The six fundamental angles or specifications that are required for a proper wheel alignment are as follows:

- Caster
- Camber
- Toe

- Steering Axis Inclination
- Toe-Out On Turns
- Tracking

**Caster**

Caster (fig. 8-48) is the steering angle that uses the weight and momentum of the vehicles chassis to lead the front wheels in a straight path. Caster is the backward or forward tilt of the steering axis that tends to stabilize steering in a straight direction by placing the weight of the vehicle either ahead or behind the area of tire-to-road contact.

Caster controls where the tire touches the road in relation to an imaginary center line drawn through the

spindle support. It is NOT a tire wear angle. The basic purposes for caster are as follows:

- To aid directional control of the vehicle
- To cause the wheels to return to the straight-ahead position
- To offset road crown pull (steering wheel pull caused by the slope of the road surface)

Caster is measured in DEGREES starting at the true vertical (plumb line). Manufacturers give specifications for caster as a specific number of degrees positive or negative. Typically, specifications list more positive caster for vehicles with power steering and more negative caster for vehicles with manual steering (to ease steering effort). Depending upon the vehicle manufacturer and type of suspension,

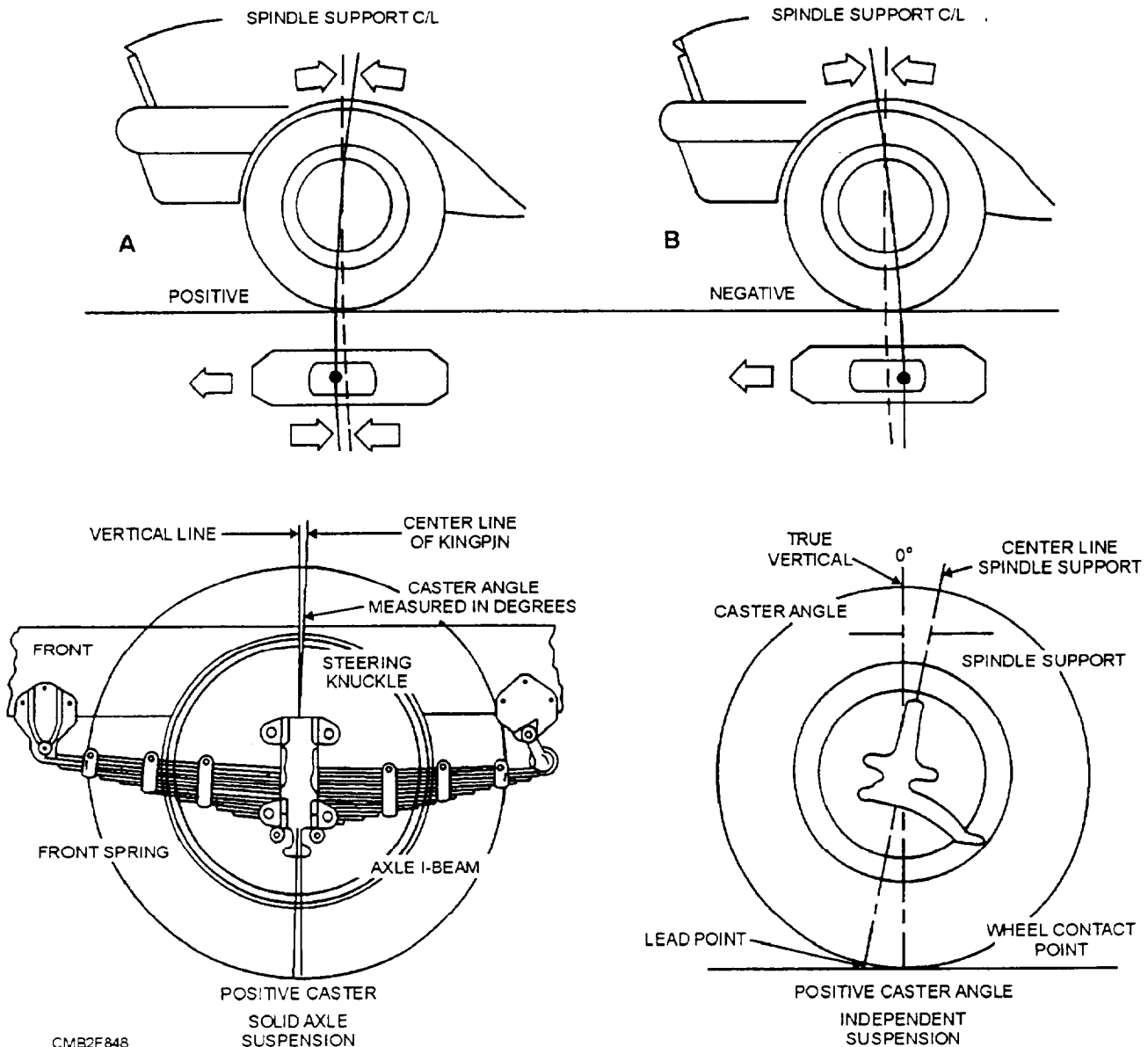

Figure 8-48.—Caster angle.

caster may be adjusted by using wedges or shims, eccentric cams, or adjustable struts.

Negative caster (fig. 8-48) tilts the top of the steering knuckle toward the front of the vehicle. With negative caster, the wheels will be easier to turn. However, the wheels tend to swivel and follow imperfections in the road surface.

Positive caster (fig. 8-48) tilts the top of the steering knuckle towards the rear of the vehicle. Positive caster helps keep the wheels of the vehicle traveling in a straight line. When you turn the wheels, it lifts the vehicle. Since this takes extra turning effort, the wheels resist turning and try to return to the straight-ahead position.

## Camber

Camber is the inward and outward tilt of the wheel and tire assembly when viewed from the front of the vehicle. It controls whether the tire tread touches the road surface evenly. Camber is a tire-wearing angle measured in degrees. The purposes for camber are as follows:

- To aid steering by placing vehicle weight on the inner end of the spindle
- To prevent tire wear on the outer or inner tread

- To load the larger inner wheel bearing

Positive and negative camber (fig. 8-49) is measured from the true vertical (plumb line). If the wheel is aligned with the plumb line, camber is zero.

With positive camber, the tops of the wheels tilt outward when viewed from the front. With negative camber, the tops of the wheels tilt inward when viewed from the front.

Most vehicle manufacturers suggest a slight positive camber setting from a 1/4 to a 1/2 degree. Suspension wear and above normal curb weight caused by several passengers or heavy loads tend to increase negative camber. Positive camber counteracts this.

## Toe

Toe (fig. 8-50) is determined by the difference in distance between the front and rear of the left and right side wheels. Toe controls whether the wheels roll in the direction of travel. Of all the alignment factors, toe is the most critical. If the wheels do NOT have the correct toe setting, the tires will scuff or skid sideways. Toe is measured in fractions of an inch or millimeters.

TOE-IN is produced when the front wheels are closer together in the front than at the rear, when

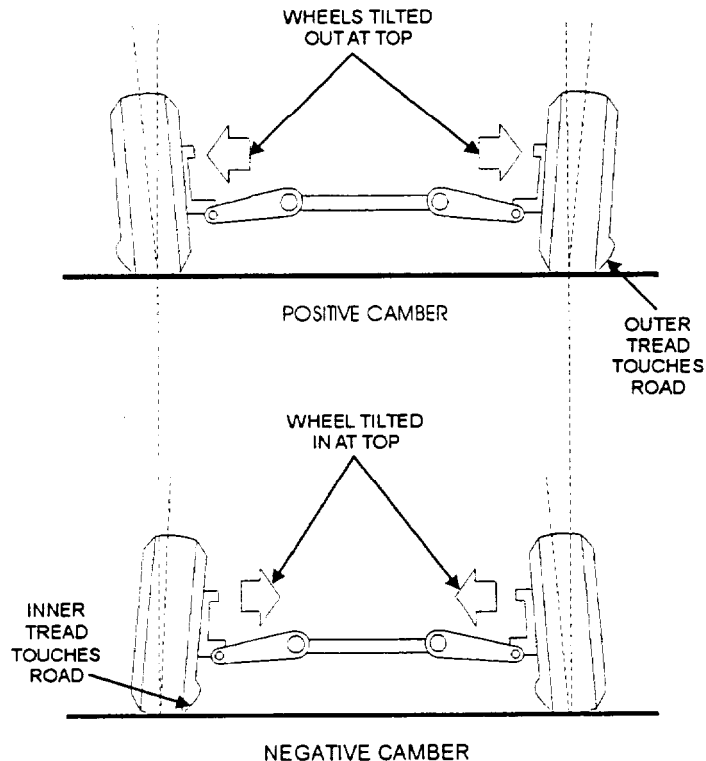

Figure 8-49.—Camber angle.

CMB2F849

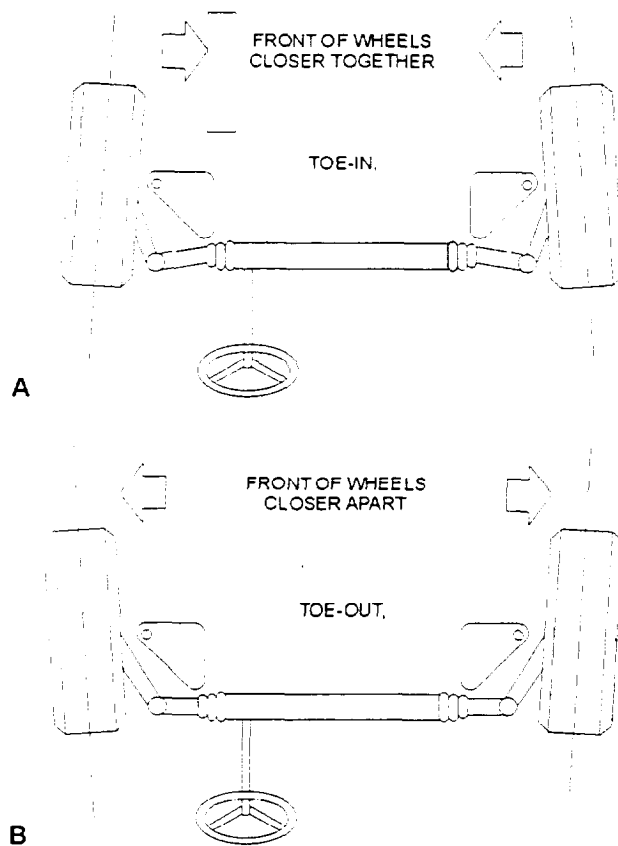

Figure 8-50.—A. Toe-in; B. Toe-out.

CMB2F850

measured at the hub height. Toe-in causes the wheels to point inward at the front.

TOE-OUT results when the front of the wheels are farther apart than the rear. Toe-out causes the front of the wheels to point away from each other.

The type of drive (rear or front wheel) determines the toe settings. Rear-wheel drive vehicles are usually set to have TOE-IN at the front wheels. This design is due to as a result of the front wheels moving outward while driving, resulting in toe-out. By adjusting the wheels for a slight toe-in (1/16 to 1/4 in.), the wheels and tires will roll straight ahead when driving.

Front-wheel drive vehicles require different adjustment for toe. This is due to the front wheels driving the vehicle and are pushed forward by engine torque. This makes the wheel toe-in or point inward while driving. To compensate for this, front-wheel drive vehicles have the front wheels adjusted for a slight toe-out (1/16 inch). This adjustment will give the front end a zero toe setting, as the vehicle travels down the road.

### Steering Axis Inclination

Steering axis inclination (SAI) (fig. 8-51) is the angle away from the vertical, formed by the inward tilt of the kingpin, ball joints, or MacPherson strut tube. Steering axis inclination is always an inward tilt regardless of whether the wheel tilts inward or outward. Steering axis inclination is NOT a tire-wearing angle. As with caster it aids directional stability by helping the steering wheel to return to the straight-ahead position.

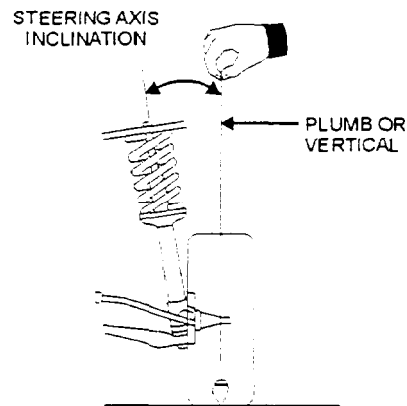

Figure 8-51.—Steering axis inclination angle.

CMB2F851



Steering axis inclination is NOT adjustable. It is designed into the suspension of the vehicle. If the angle is not correct, then the suspension system should be checked for damaged or worn parts. Replace the parts to correct the problem.

### Toe-Out On Turns

Toe-out on turns, also known as turning radius angle, is the amount the front wheels toe-out when turning corners. As the vehicle goes around a turn, the inside tire must travel in a smaller radius circle than the outside tire. To accomplish this, the steering arms are designed to angle several degrees inside of the parallel position. The exact amount depends on the tread and wheelbase of the vehicle and on the arrangement of the steering control linkage. Toe-out on turns is NOT an adjustable angle. If the angle is incorrect, it is an indication of damaged steering components.

Figure 8-52 shows toe-out on turns. Note how each front wheel turns a different number of degrees. This prevents tire scrubbing and squeal by keeping the tires rolling in the right direction on corners.

### Tracking

Tracking (fig. 8-53) is the ability of the vehicle to maintain a right angle between the center line of the vehicle and both front and rear axles or spindles. (The rear of the vehicle should follow the front wheels.) With improper tracking, the vehicle rear tires do NOT follow the tracks of the front tires. This causes the vehicle body or frame to actually shift partially sideways when moving down the road. Poor tracking

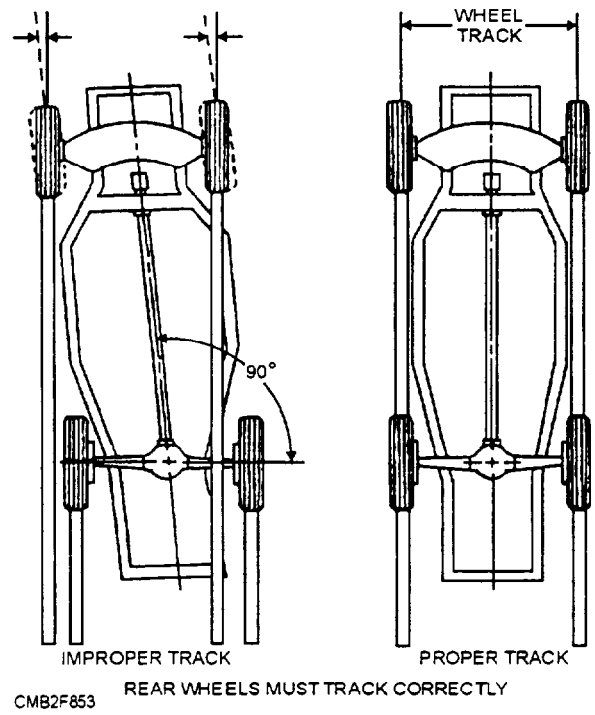

Figure 8-53.—Tracking.

will increase tire wear, lower fuel economy, and upset handling.

Improper tracking has many causes, such as shifted or broken leaf springs, bent or broken rear axle mounts, bent frame, bent steering linkage, or a misadjusted front end alignment.

### WHEEL ALIGNMENT TOOLS AND EQUIPMENT

The most basic types of equipment for wheel alignment are the turning radius gauge, the caster-camber gauge, and the tram gauge. These are

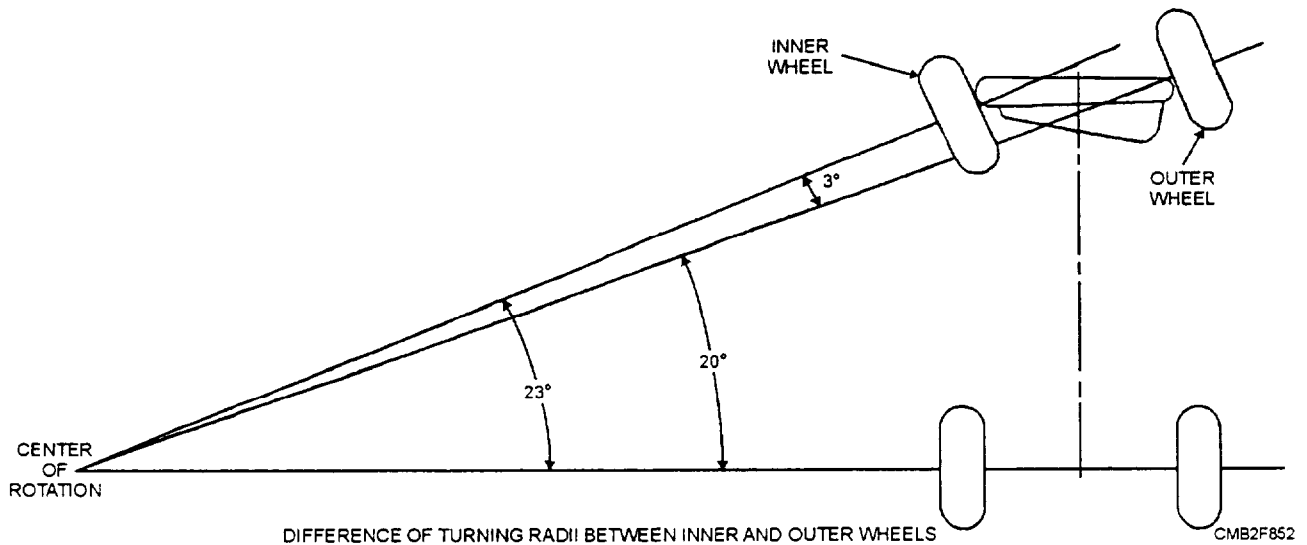

Figure 8-52.—Toe-out on turns.

the least complicated of all alignment equipment and illustrate the fundamentals for wheel alignment easily.

In larger shore facilities these basic types of equipment are normally replaced with a large alignment rack. The alignment rack consists of ramps, turning radius gauges, and specialized equipment for measuring alignment angles.

### Turning Radius Gauges

Turning radius gauges (fig. 8-54) measure how many degrees the front wheels are turned right or left. They are used when measuring caster, camber, and toe-out on turns.

The portable type turning radius gauges are the most common in the Naval Construction Force (NCF). However, they are also mounted on alignment racks as integral units.

The front wheels of the vehicle are centered on the turning radius gauges. With the front wheels centered, the locking pins are pulled out which allows the gauge and tire to turn together. The pointer on the gauge will indicate how many degrees the wheels have been turned.

The procedures for checking toe-out on turns using turning radius gauges are as follows:

- Center the front tires of the vehicle on the turning radius gauges and remove the locking pins.
- Turn one of the front wheels until the gauge reads 20 degrees.

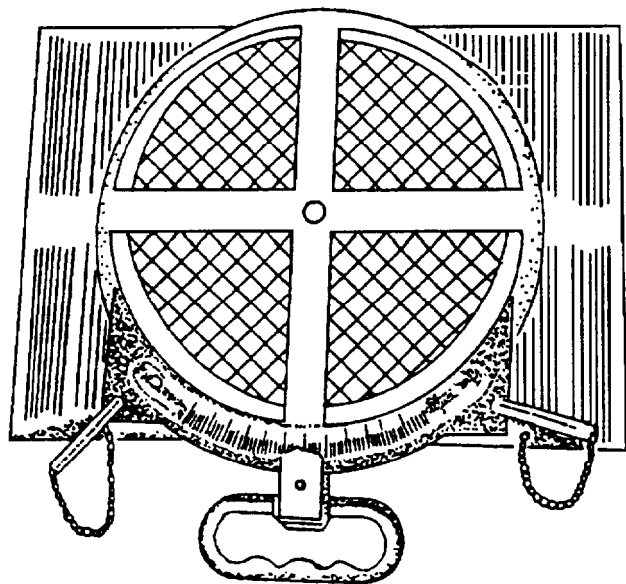

CMB2F854

Figure 8-54.—Turning radius gauge, portable type.

- Then read the number of degrees showing on the other gauge. Check toe-out on turns on both right and left sides. Note the readings.
- If not within manufacturer specifications, check for bent or damaged components.

### Caster-Camber Gauge

The caster-camber gauge is used with the turning radius gauge to measure caster and camber in degrees. The caster-camber gauge either fits on the hub magnetically (fig. 8-55) or may be mounted on the wheel with an adapter (fig. 8-56). Caster and camber are adjusted together since one affects the other.

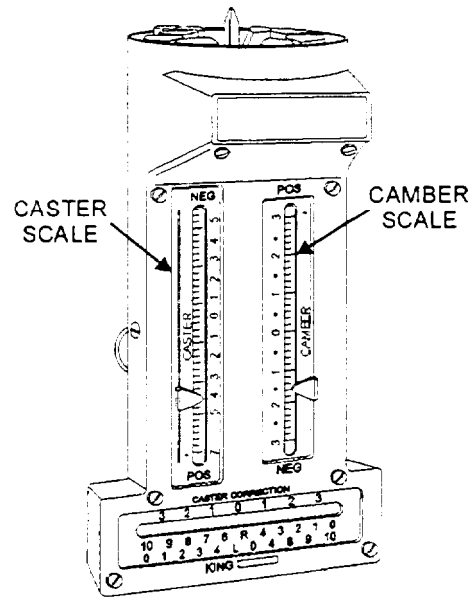

CMB2F855

Figure 8-55.—Magnetic Caster-Camber Gauge.

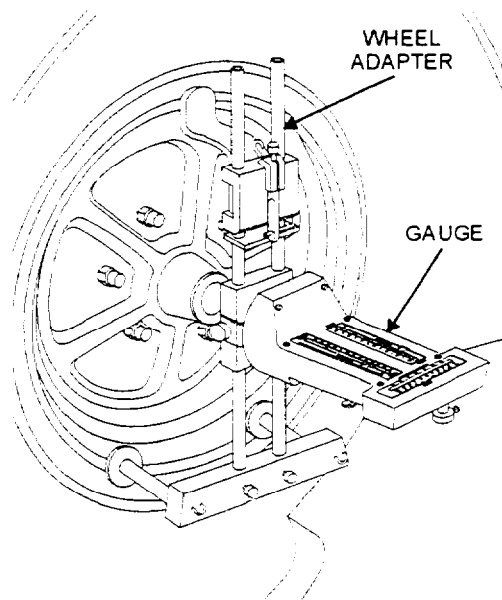

CMB2F856

Figure 8-56.—Caster-Camber Gauge mounted on a wheel adapter.

The procedures for using a caster-camber gauge for measuring caster are as follows:

- With the vehicle centered on the turning radius gauges, turn one of the front wheels inward until the turning radius gauge reads 20 degrees.
- Turn the adjustment knob on the caster-camber gauge until the bubble is centered on zero. Then turn the wheel out 20 degrees.
- The degree marking next to the bubble will equal the caster of that front wheel. Compare the reading to the manufacturer's specifications and adjust as needed.
- Repeat this operation on the opposite side of the vehicle.

The procedures for using a caster-camber gauge for measuring camber are as follows:

- With the vehicle on a perfectly level surface, turn the front wheels straight ahead until the turning radius gauges read zero.
- Read the number of degrees next to the bubble on the camber scale of the caster-camber gauge. This will show camber for that wheel. If not within manufacturer's specifications, adjust the camber.
- Double-check the caster readings, especially when an excessive amount of camber adjustment is required.

#### NOTE

If shims are used to adjust camber, add or remove the same amount of shims from the front and rear of the control arm. This will keep the caster set correctly,.

#### Tram Gauge

The tram gauge (fig. 8-57) is a metal rod or shaft with two pointers, used to compare the distance between the front and rear of the tires of the vehicle for toe adjustment. The pointers slide on the gauge so they can be set to the distance between the tires. The tram gauge will indicate toe-out or toe-in in inches or millimeters.

The procedures for using a tram gauge for measuring toe are as follows:

- Raise the front wheels of the vehicle and rub a chalk line all the way around the center rib on each tire.

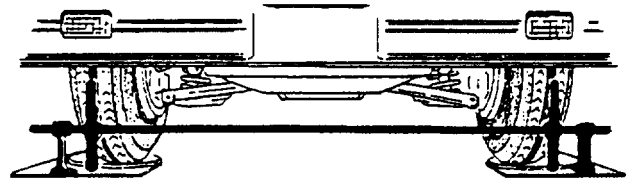

CMB2F857

Figure 8-57.—Tram gauge.

- With a scribing tool, rotate each tire and scribe a fine line on the chalk line. This will give you a very thin reference line for measuring the distance between the tires.
- Lower the vehicle back on the turning radius gauges.
- Position the tram gauge at the back of the tires. Move the pointers until they line up with the scribe marks on the tires.
- Without bumping the tram gauge pointers, reposition the gauge to the front of the tires. The difference between the lines on the front and rear of the tires shows toe.

If the lines on the front of the tires are closer together than on the rear, the wheels are toed-in. If the lines are the same distance apart at the front and rear, toe is zero. Use the manufacturer's service manual for specifications and adjustment procedures.

#### REVIEW 5 QUESTIONS

- Q1. Define the term alignment.
- Q2. What are the six fundamental angles required for proper wheel alignment?
- Q3. What gauge is used to compare the distance between the front and rear of the tires of the vehicle for toe adjustment?

#### BODY REPAIR

**Learning Objective:** Describe the procedures for repairing and refinishing automotive bodies. Explain the Naval Construction Force (NCF) policy on corrosion control.

The automotive body provides protection for the engine, power train components, operator, and any cargo or passengers. At the same time, it adds strength to the frame and provides adequate vision for the operator. Last but not least, the body design provides a pleasant outward appearance.

For military vehicles, appearance is secondary. The Naval Facility Engineering Command (NAVFAC) who controls all Navy vehicles states that transportation equipment will be repainted when inadequate protection is afforded against rust and corrosion. It also states that spot painting should be used instead of complete painting unless necessary for protection of the entire vehicle.

Part of your job as a Construction Mechanic is to perform body maintenance of the vehicles assigned to your command. In order to perform this task, you must know the procedures used for straightening fenders and body panels. Preparation and painting of the vehicle is another important task associated with this responsibility.

### BODY TOOLS

Regardless of whether the vehicle is in need of extensive bodywork or has a dented fender, it is desirable to have a number of special tools. One of the most important tools required to repair heavily damaged areas is a portable hydraulic jack (porta-power) (fig. 8-58). The porta-power is provided with a number of adapters or accessories that will allow you to use it in many types of body repair work. This tool when applied, as shown in figure 8-59, will force the damaged area to return to near original shape and save many hours of labor.

Spoons (fig. 8-60) dinging hammers (fig. 8-61) and dolly blocks (fig. 8-62) are the common working tools found in the body shop. These tools are used to remove dents and smooth out and shape damaged areas.

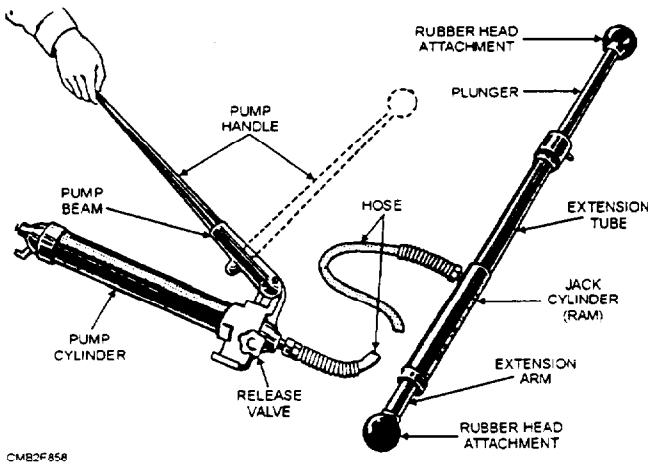

Figure 8-58.—Portable hydraulic jack.

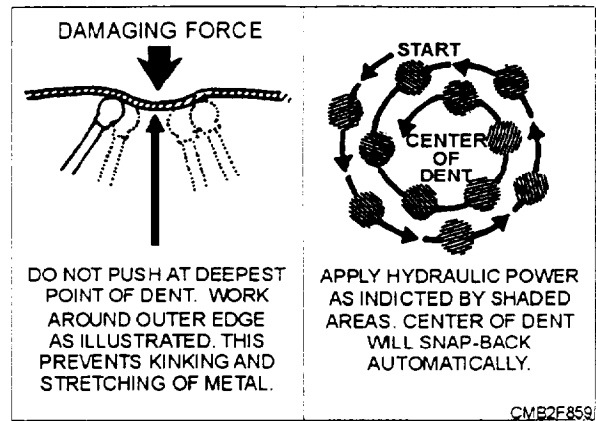

Figure 8-59.—Pushing a body dent out using a portable hydraulic jack.

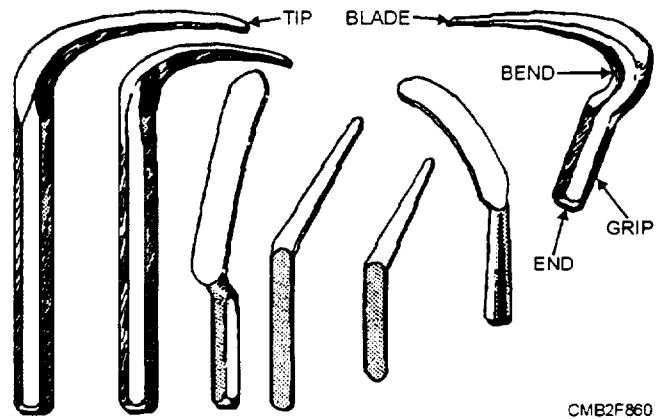

Figure 8-60.—Spoons used in the body repair shop.

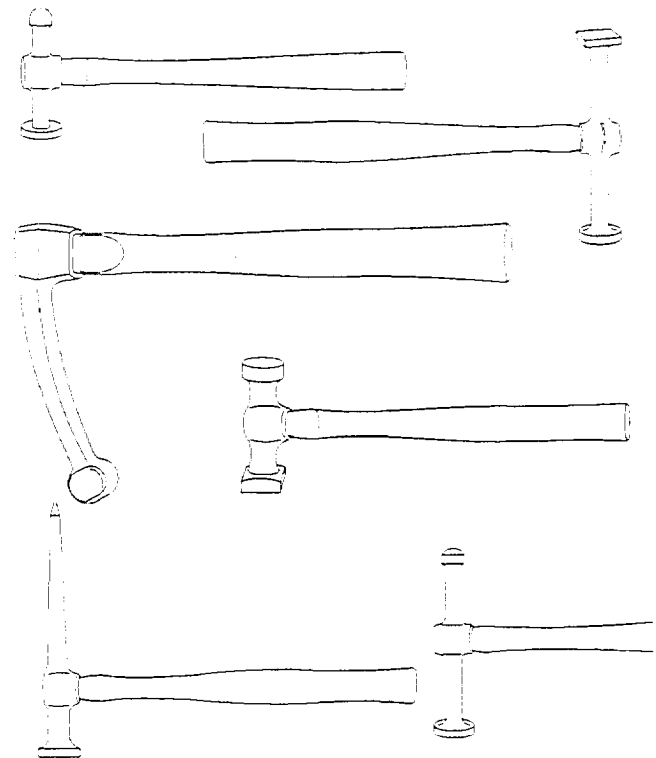

Figure 8-61.—Dinging hammers used to remove dents.

## REMOVING DENTS

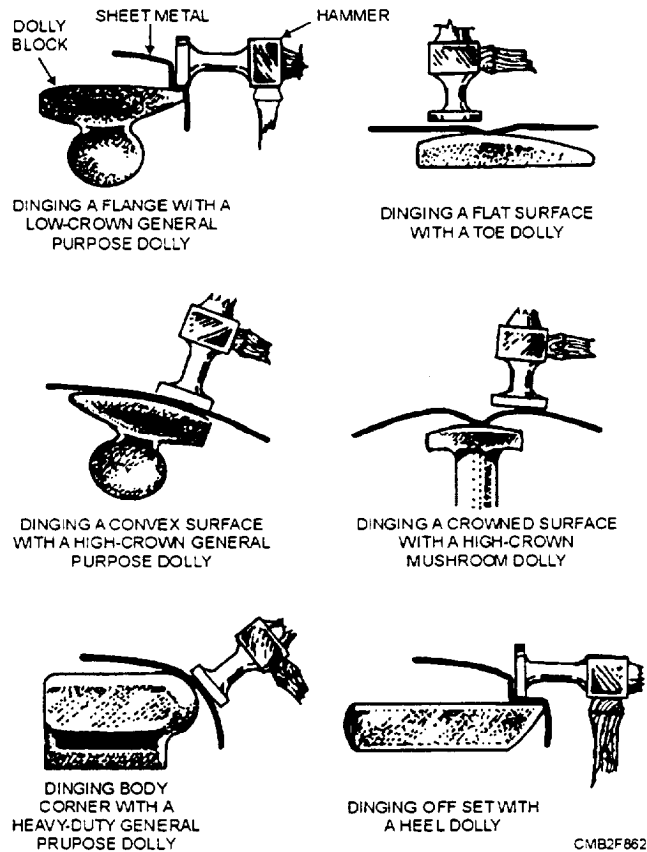

Figure 8-62.—Dolly blocks used to shape body panels.

### NOTE

Make sure the surfaces of the spoons, hammers, and dollies are free from scratches and/or dents. Surface defects on these tools will cause similar defects in the sheet metal they are used on. To remove surface defect on these tools, use a file and fine grit sandpaper until you have a smooth surface.

With these tools and experience you will be able to remove the dents and creases while restoring the body to a like-new condition. The ease and speed with which you can straighten the sheet metal is dependent on starting the repair work at the right point and the correct use of the tools. If this is done, the amount of “dinging” (light tapping of the metal with a hammer) required to remove the dent is reduced considerably. As metal is dinging and formed, a certain amount of stretching occurs. This causes additional work when nearing completion of the repair. Always remember, when straightening a damaged panel, the damage should be removed in reverse order of how it occurred.

Before attempting any body repairs, scrape off any undercoating or foreign matter located in the area to be repaired. Dirt or undercoating will cake on the dolly block. No amount of hammering will produce a smooth surface when this occurs. Next make sure the outer side is clean to protect the hammer.

Without prior body repairing experience, a mechanic will usually start applying pressure at the spot where the panel was struck first and is depressed the most. The CORRECT METHOD is to apply pressure at the ridge farthest from the point of impact. To make the procedure clear, refer to the damaged panel in figure 8-63.

Assume that the original form of the panel is shown as the dotted line. Point Y is where it was struck, and X is a ridge that was formed last. With the use of a spoon and hammer or mallet, place the spoon on the ridge (X) and strike it with the hammer. Aim your hammer blows directly at the ridge (X). By following the ridge with the spoon and hammer, you will find that the ridge will gradually disappear while the major portion of the depression at point Y will spring back and very closely resemble the original contour of the panel.

Using a dolly block with the same general curvature as the panel, place it under the panel at point O and strike the dent as shown. In this way, the dolly block acts as a hammer and raises the dented portion to the original contour, as the dolly block is gradually moved toward point Z. The most common mistake made by an inexperienced body repairman is trying to do all the work with one blow of the dolly. All that is necessary of the hammer or dolly is to press the metal back into position. A number of light blows with the hammer or dolly is better than a few heavy ones. Heavy blows result in the metal stretching excessively during the straightening process. This requires that the panel be shrunk later to remove bulges.

When working with the hammer, apply blows rapidly with a pulling action so the hammer tends to slide as it contacts the metal. Above all, don't try to rush the job by striking the metal too heavily. Figures 8-64 and 8-65 show the procedures for removing dents when performing bodywork. Use of a flat-faced hammer should be confined to the flat or nearly flat surfaces and the outside of curved surfaces. Hammers with crowned faces are for use on concave surfaces only.

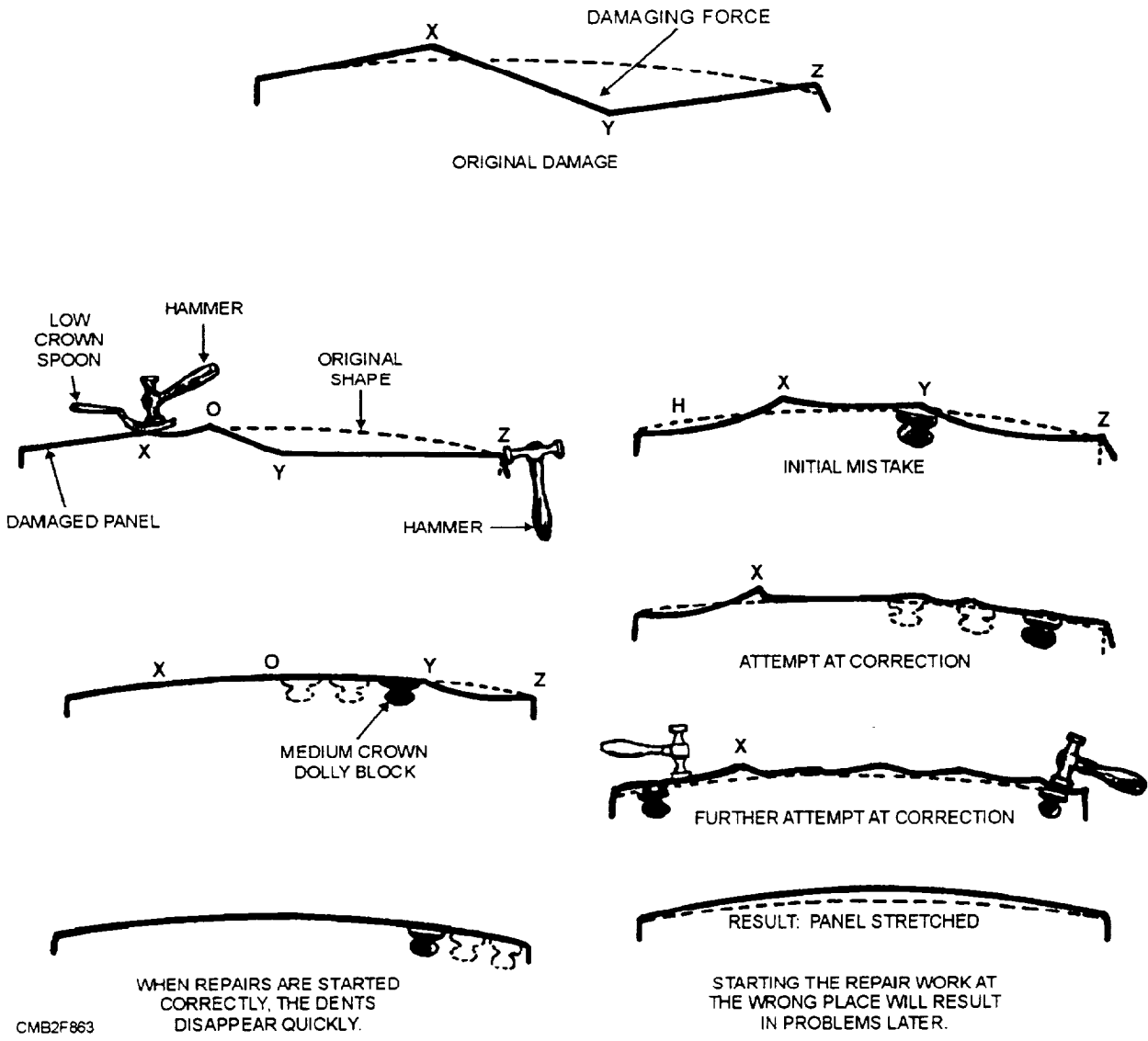

Figure 8-63.—The correct and incorrect methods for repairing a damaged body panel.

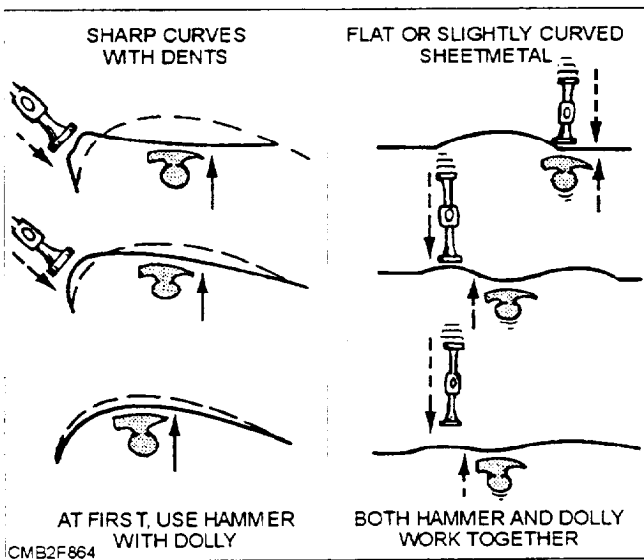

Figure 8-64.—Arrow indicates direction metal must move to return to original contour.

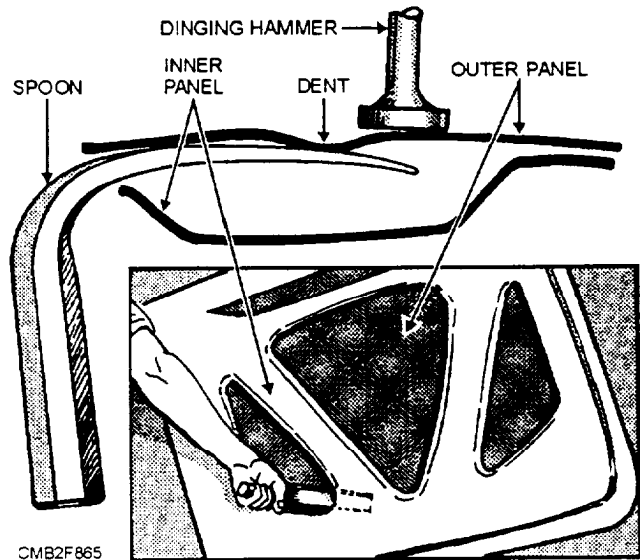

Figure 8-65.—The spoon can be used as both a lever and dolly when working in tight places.

## REPLACING SHEET METAL

Generally, a severely damaged panel will be replaced or repaired by cutting out the damaged area and replacing it with sheet metal. Should you have to repair a heavily damaged body panel, there are a few things you should consider before starting the job.

The first and most important consideration is to determine the direction of force that caused the damage. This will enable you to use the hydraulic jack and its attachments to push the panels back into a near original position. At the same time, the braces holding the sheet metal will move back to their original position and allow access to any bolts and fasteners that must be removed to disassemble the damaged body parts. Once you have reached this point, it must be determined if the damaged panel is to be repaired or replaced.

If you decide to replace the damaged panel, make sure any braces that support the panel are ordered also. New braces will assist in aligning the new panels with the rest of the body. Should only a portion of the damaged panel be replaced, a oxygas cutting and welding outfit (fig. 8-66) will be required to remove the damaged portion and weld the new sheet metal into position.

### NOTE

Complete instructions on the use and care of oxygas cutting and welding outfit are contained in the current edition of the *Steelworker* training manuals. Consult these manuals for the proper method for adjusting and using the cutting and welding tips.

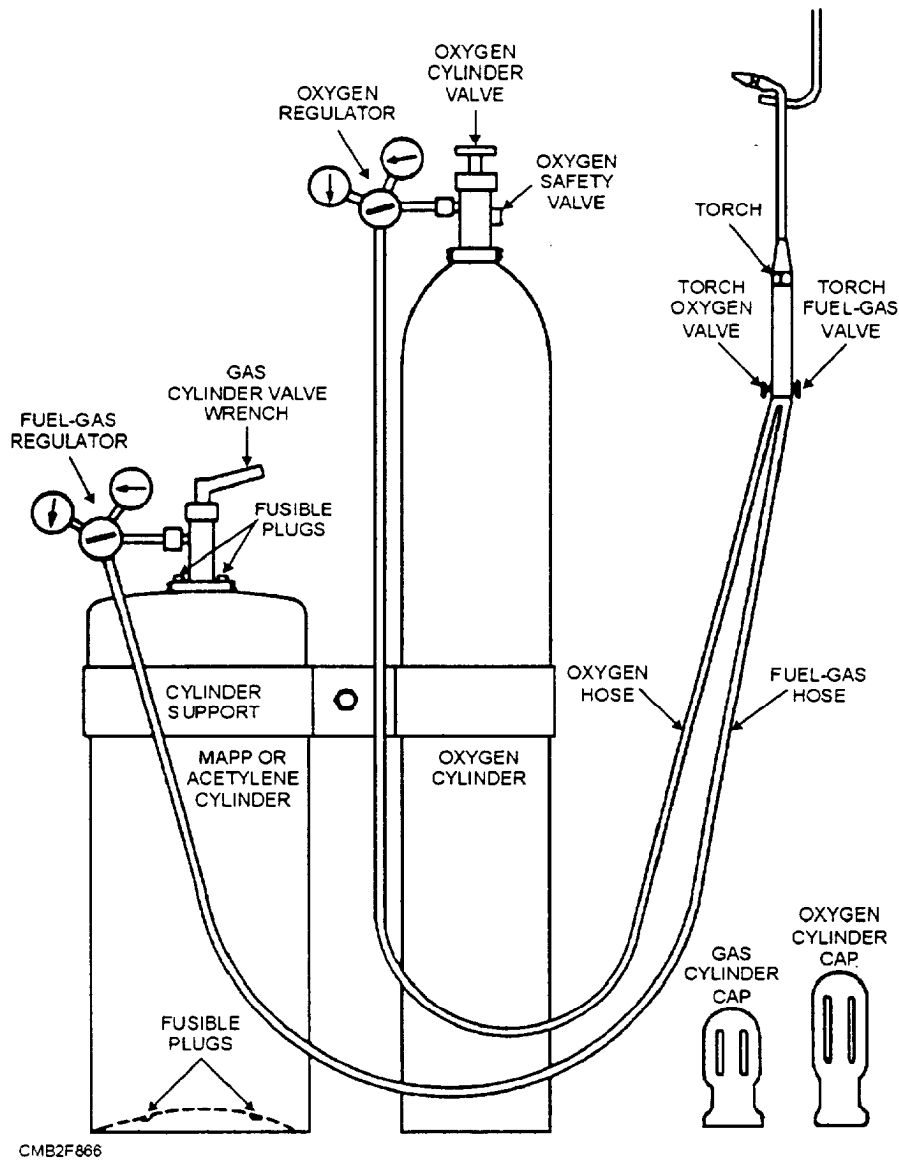

Figure 8-66.—Oxygas cutting and welding outfit.

The procedures for replacing a portion of a damaged panel are as follows:

- Determine the amount of damaged area to be removed. Using oxygas cutting and welding equipment removes the damaged area.
- Once the section of the damaged panel has been removed, straighten the remaining portion to the original contour.
- Place a piece of sheet metal over the area that is cut away. Mark the new sheet metal so that when you cut on the lines drawn, the piece will be slightly larger than the area being replaced.
- With the new piece of sheet metal held in place by clamps, weld the sheet metal into place. Work out to the sides then down the sides. Make a continuous weld, doing a length about 6 inches long at a time. To reduce distortion, stagger the welds.

- With the new sheet metal welded into place, the weld should be ground down using a disc sander. Exercise care while sanding to prevent burning or cutting holes in the sheet metal.

When replacing sheet metal, it may be necessary to shrink the sheet metal in order to achieve a professional fit and finish. Figure 8-67 shows the procedure for shrinking sheet metal. Only a small area at a time is heated and shrunk. This will cause the panel to return to its original contour when performed properly.

### PREPARING THE SURFACE FOR PAINTING

Before actual painting begins, it is essential that you prepare the surface for the paint by removing all traces of wax, grease, oil, and dirt. If the paint on the vehicle is of poor quality or deteriorated, remove it. In

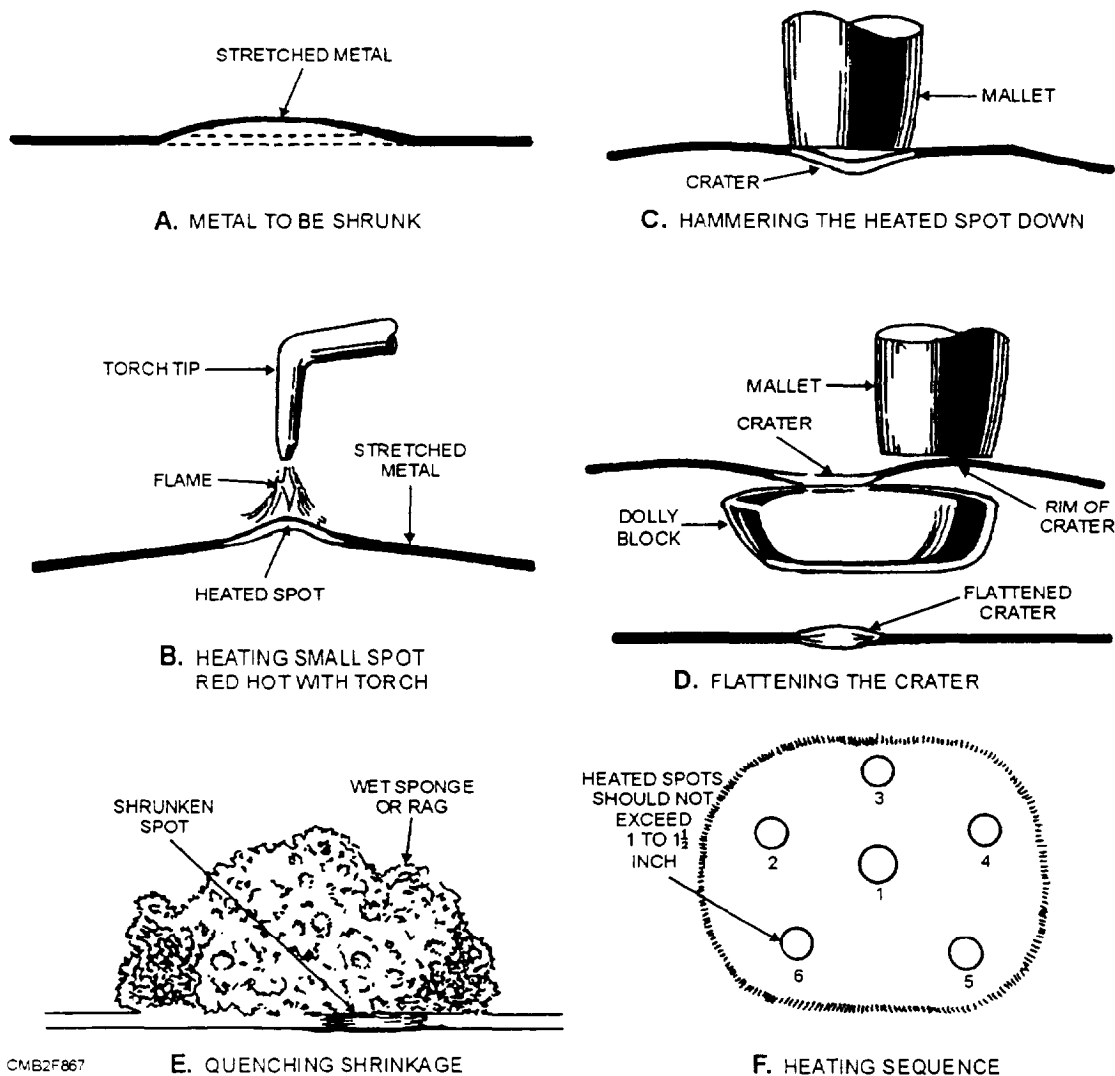

Figure 8-67.—Metal shrinking process and sequence used for large areas.



this final preparation of the body before applying paint, you have several methods to choose from. The method that is selected depends on the condition of the existing paint, the equipment available, and the quality of the desired finish product.

If the paint on the vehicle is in good condition (good adherence and without surface defects), go over the surface with a disc sander. An open-coated disc of No. 16 to 24 grit is recommended. This will remove most of the old finish down to the metal. Follow this with a No. 50 close-coated disc to remove any scratches.

If the paint is to be removed from only a portion of the panel, taper the sanded area down into the old paint to produce a featheredge. Follow-up with a 150 grit paper in a block sander, and complete the featheredge by water sanding using wet or dry paper of 280 or 320 grit.

### NOTE

Some manufacturers of abrasive paper advise different grits with variations of the above procedure. Follow the instructions of the manufacturer.

For removing paint from the entire vehicle, sandblasting is the preferred method. Among the advantages claimed for sandblasting method are speed, low cost, and a surface that has good paint adherence.

After removing the old paint, clean the surface with a cleaning agent. If none is available, a lint-free cloth saturated with paint thinner can be used to wipe down the surface. This will help the new paint to adhere to the metal and remove the dust and other foreign matter.

Apply the primer coat as soon as possible after the paint is removed. This is particularly important when the surface has been sandblasted, because the surface is practically in a raw state and quickly starts rusting.

### PAINTING

Equipment shall be repainted when inadequate protection is afforded against rust and corrosion. Equipment will NOT be repainted merely to change the color or gloss characteristics if the finish is serviceable. Spot painting, in lieu of completely refinishing previously painted sections, should be done whenever practicable. Bare surfaces of body sections and sheet metal exposed by deterioration of

paint or by accidents shall be spot painted immediately to prevent deterioration of the metal.

### WARNING

When using any paint product, particularly lead-base paint, all current health and safety regulations will be strictly enforced. Contact the activity health/safety department/office to obtain all applicable regulations and instructions pertaining to a safe painting environment.

All Navy equipment shall be treated and painted in accordance with MIL-STD-1223. Equipment painting shall meet all specifications and standards referenced within MIL-STD-1223. Colors and color numbers that are authorized for use when painting CESE are as follows:

- YELLOW 13538
- GREEN 14064
- SAND 33303
- BLACK 17038
- WHITE 17886
- GRAY 16187
- RED 11105

Before painting, a coat of primer should be applied to prevent peeling and flaking where bare metal is exposed. The primer serves as a bond between the paint and the metal of the vehicle. Each coat of primer that is applied should be allowed to dry and must be sanded lightly between coats. There may be occasions to use two coats of primer, but normally one coat is adequate.

Paint and primer must be shaken or stirred thoroughly, thinned with a thinning agent, and ran through a strainer or filter when using a spray gun. One of the "musts" of spray painting is that the paint should have the correct viscosity. This can be determined by following the instruction of the paint can. Too many painters determine the viscosity by the rate at which the paint runs from the stirring stick. This can lead to plenty of trouble, since only a slight change in viscosity can spoil an otherwise good job. This happens because the amount of thinner not only determines the thickness of the coat but also influences the evaporation rate between the time the material leaves the spray gun and the time it contacts the body panel.

## NOTE

High viscosity paint produces paint sag and orange peel, while low viscosity paint produces improper flow out and waste of thinner. To avoid these problems, take care to measure the proportions of thinner and paint accurately in a graduated measuring cup.

The temperature at which the spraying is done is also an important factor in turning out a good job. This applies not only to the temperature of the shop but also to the temperature of the vehicle. Shop temperatures should be maintained at approximately 70°F. Whenever possible, bring the vehicle into the shop well in advance of painting so that it becomes the same temperature as the shop. Spraying paint on a surface that is too cold or too hot from being in the sun will upset the flowing time of the material and will cause orange peel and poor adherence to the surface.

Another important factor in doing a good job is the thickness of the paint film on the surface. Obviously, a thick film takes longer to dry than a thin one. As a result, the paint will sag, ripple, or orange peel. Ideally, you should produce a coat that will remain wet long enough for proper flow out, but no longer. The amount of material you spray on a surface with one stroke of a gun will depend on the width of the fan, the distance of the gun from the sprayed surface, the air pressure, and the amount of thinner used.

In addition, the speed of the spray stroke will also affect the thickness of the coat. The best procedure is to adjust the gun to obtain a wet film, which will remain wet only long enough for good flow out. Get the final thickness by spraying an additional coat after the first one has dried.

Nearly all-standard spray guns are designed to provide optimum coverage when held at a distance of 8 to 12 inches from the surface to be painted. When the gun is held too close, the air pressure tends to ripple the wet film, especially if the film is too thick. If the distance is too great, a large percentage of the thinner will be evaporated in the spraying operation. Orange peel or a dry film will result, because the spray droplets will not have opportunity to flow together.

It is imperative, then, to hold the spray gun at the specified distance from the work. In addition, do NOT tilt or hold the spray gun at an angle. Also, never swing the spray gun in an arc, but move it parallel to the work. The only time it is permissible to fan the gun is when you want the paint to thin out over the edges of a small

spot. Figure 8-68 shows the method for using a spray gun.

Another ingredient that is sometimes added to the paint is "drier." This substance causes the paint to set and dry much more rapidly than normal. Because a small amount of drier is all that is required, the instruction on its use must be followed closely. Mixing paint and adding drier are two critical parts of painting vehicles. Use of the wrong type of thinner, paint, or excessive drier will cause the paint to fade, peel, or blister within a short period of time after completing the job.

Painting instructions for using chemical agent resistant coating (CARC) and the camouflage painting of CESE equipment are found in the NAVFAC P-300.

## EPOXY FILLERS

Epoxy fillers (body fillers) are simple to use in that the body portions do not have to be straightened as closely as when making repairs without it. By using the manufacturer's instructions, you can apply body filler over rough places and form it with a body file or sanding until it conforms to the desired contour.

The advantage of using body filler lies in the fact that a badly damaged vehicle can be returned to a like-new appearance quickly and with a limited amount of metal straightening. Additionally, the use of thinner metals in the bodies of modern vehicles makes it difficult to reform panels into their original shape.

Should you have an opportunity to use an epoxy filler, the recommended thickness of the filler should be kept to approximately 1/8 inch. If more is required, it should be applied in coats and allowed to dry before applying the next coat. Do not exceed an overall thickness of 1/4 inch.

## IDENTIFICATION MARKINGS

Once a vehicle has been repainted, you will be required to replace the vehicle identification markings. The placement of registration numbers and other equipment markings for identification purposes, as required by law, are described in the NAVFAC P-300 and COMSECOND/COMTHIRDNCBINST 11200.1.

## CORROSION CONTROL

Civil Engineer Support Equipment (CESE) is assigned to many locations where atmospheric and environmental conditions can cause severe corrosion

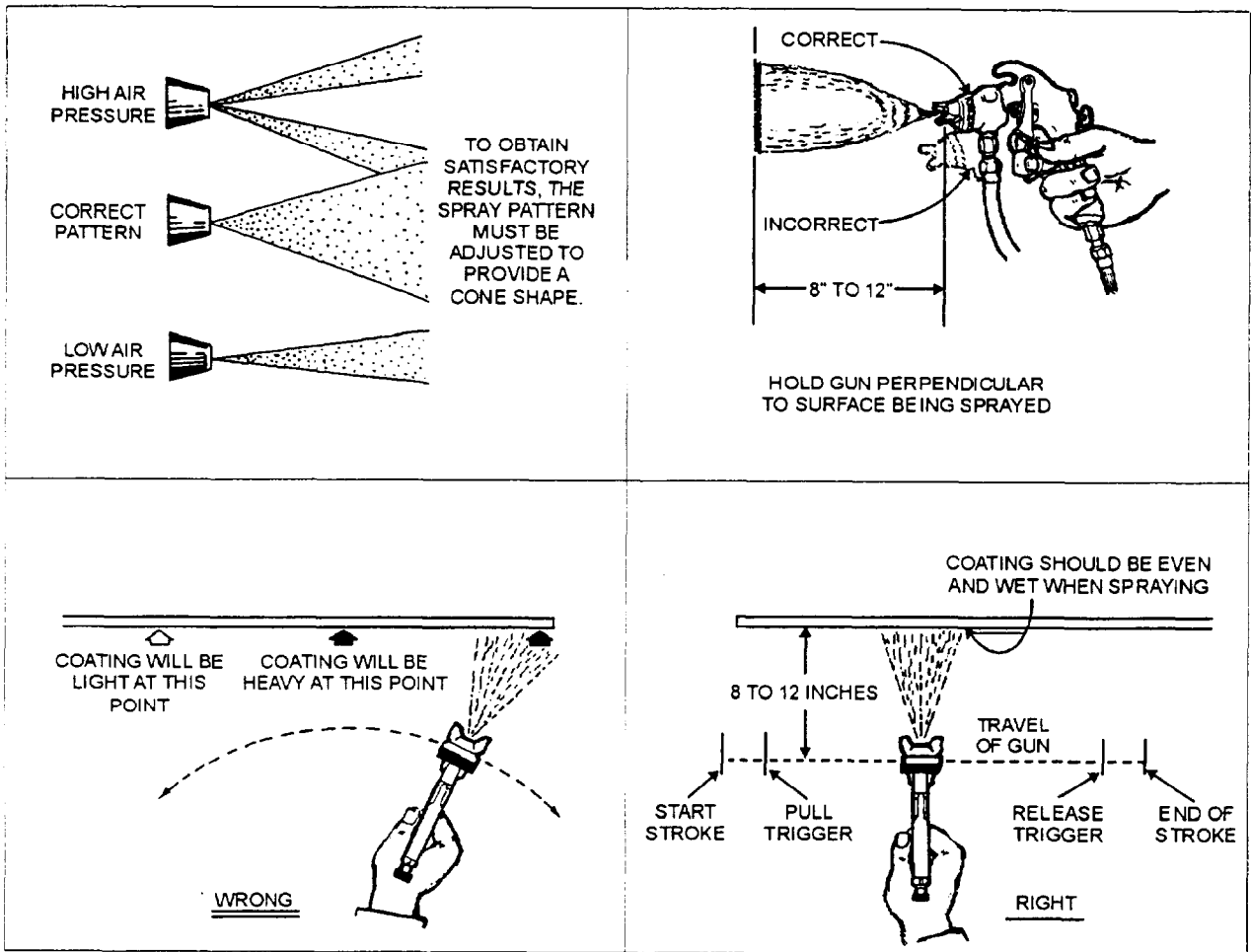

HOLDING AND MOVING THE SPRAY GUN CORRECTLY IS AS IMPORTANT AS THE SPRAY PATTERN

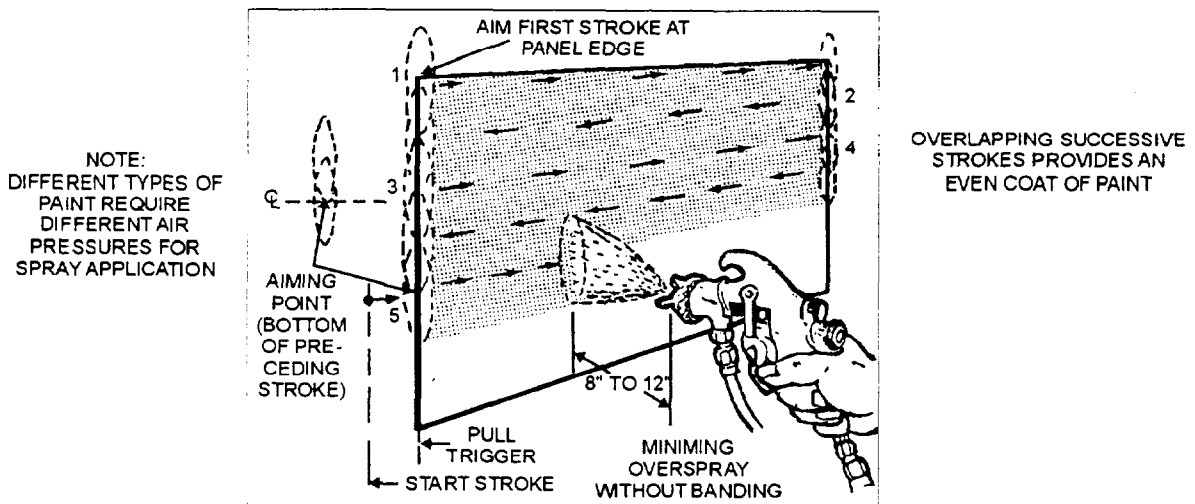

CMB2F868

OVERLAPPING EACH PASS  
Figure 8-68.—Proper operation of a spray gun.

and a reduction in equipment life. Corrosion can be slowed by proper cleaning and the correct application and maintenance of protective coatings, such as paint, undercoating, and preservatives. Body corrosion

occurs primarily where poor ventilation caused by clogged drain holes or accumulations of mud and sand allow moisture to remain on unprotected metal surfaces.

All automotive CESE will be core-treated. Proper application and preparation of the areas to be coated or recoated is necessary. Surfaces shall be reasonably clean, dry, and free of excessive rust, oil, grease, dust, road tar, and other foreign matter. Core treatment of a vehicle will be inspected during each preventive maintenance (PM) service: one scratch through the preservative can cause corrosion to start beneath the rustproofing.

The NAVFAC P-300 identifies and describes the different preservative compounds applicable on CESE. Additional information can be obtained from

the NAVFAC P-434, *Construction Equipment Department Management and Operations Manual*.

### **REVIEW 6 QUESTIONS**

- Q1. What items are used to remove surface defects on body spoons, hammers, and body dollies?*
- Q2. What is the preferred method for removing paint from the entire vehicle?*
- Q3. What instruction provides information for using chemical agent resistant coating?*

## REVIEW 1 ANSWERS

- Q1. Cross member*
- Q2. Monocoque*
- Q3. False*

## REVIEW 2 ANSWERS

- Q1. Strut rod*
- Q2. Limits body roll of the vehicle during cornering*
- Q3. Outer end of the control rod*
- Q4. Double-acting, double-action type*
- Q5. Upper control arm*
- Q6. Spring rate*
- Q7. False*
- Q8. Strut spring compressor*

## REVIEW 3 ANSWERS

- Q1. Parallelogram*
- Q2. False*
- Q3. Tie-rod assemblies*
- Q4. Steering linkage ratio and gear ratio of the steering mechanism*
- Q5. Recirculating ball*
- Q6. Power steering pump*
- Q7. Integral piston, external cylinder, and rack and pinion*
- Q8. Rack guide adjustment*
- Q9. Excessive steering wheel play*
- Q10. Excessively tight adjustment in the steering gearbox or linkages*

## REVIEW 4 ANSWERS

- Q1. Acts as a soft cushion between the road and the metal wheel and provides adequate traction with the road surface.*
- Q2. Tire beads, body plies, tread, sidewall, belts, and liner*
- Q3. Produces a harder ride at low speeds.*
- Q4. Tire size, load index, speed rating, inflation pressure, and the UTQG ratings for treadwear, traction, and temperature*
- Q5. Drop center*
- Q6. Tapered roller and ball bearing*
- Q7. False*

### **REVIEW 5 ANSWERS**

*Q1. To position in a straight line*

*Q2. Caster, camber, toe, steering axis inclination, toe-out on turns, and tracking*

*Q3. Tram gauge*

### **REVIEW 6 ANSWERS**

*Q1. A file and fine grit sandpaper*

*Q2. Sandblasting*

*Q3. NAVFAC P-300*

## APPENDIX I

# GLOSSARY

- ABS**—An abbreviation for "anti-lock braking system."
- ABS SWITCH**—Sensor that monitors hydraulic system pressure and controls the pump motor in an ABS application.
- AC**—Alternating current.
- AC GENERATOR**—A device that produces alternating current; an alternator.
- ACTUATOR**—A device that performs an action or outputs a signal in response to a signal from a computer.
- AIR BRAKES**—Vehicle brakes actuated by air pressure.
- AIR COMPRESSOR**—A pump that forces air, under pressure, into a storage tank.
- ALTERNATOR**—An ac generator.
- ALTERNATOR BEARING**—Needle- or ball-type bearings used to provide a low friction surface for a rotor.
- AMMETER**—An electric meter that measures current, in amperes, in an electric circuit.
- AMPERE**—A unit of electric current flow measurement.
- ANTI-LOCK BRAKE COMPUTER**—ECM that accepts wheels sensor inputs and controls braking of the vehicle.
- ANTI-LOCK BRAKES**—Computer controlled brakes that will not "lock" and permit the wheels to skid.
- ANTI-RATTLE CLIPS**—Metal components designed to keep brake pads from vibrating and rattling.
- ANTI-SKID SYSTEM**—Another name for anti-lock braking system.
- ARMATURE**—Rotating support for multiple windings in a motor.
- ASPECT RATIO**—The relationship of tire height to width or profile.
- AUTOMATIC TRANSMISSION**—A transmission that does not have to be shifted manually.
- AUTOMATIC TRANSMISSION FLUID**—Oil with special additives to make it compatible with friction clutches and bands.
- AUTOMOTIVE CLUTCH**—A mechanical device used to connect and disconnect a manual transmission from engine power.
- AXLE**—A cross support on a vehicle on which supporting wheel, or wheels, turn(s).
- AXLE END PLAY**—In-and-out movement of the axle, adjusted to specification by using shims.
- AXLE SHAFT RETAINER**—Devices that attach to the outside of an axle housing to prevent the axles from sliding out.
- AXLE SHIMS**—Used between the axle housing and retainer to limit end play of the axle.
- BACKLASH**—The backward rotation of a driven gear that is permitted by clearance between meshing teeth of two gears.
- BACKING PLATE**—A component that holds the shoes, wheel cylinder, and other parts inside a brake drum.
- BACKUP LIGHT SWITCH**—An electrical switch that completes a circuit to the backup lights whenever the reverse gear is engaged.
- BALL JOINT**—Swivel joint that provides free movement for the steering knuckle and control arm.
- BALL SOCKETS**—Component that allows motion in up-and-down and side-to-side directions.
- BAND**—Metal strap with frictional material lining that can clamp a clutch drum in an automatic transmission to stop its rotation.
- BAND ADJUSTMENT**—Checking and altering tightness of automatic transmission bands as necessary for proper operation.
- BATTERY**—A device consisting of two or more cells for converting chemical energy into electrical energy.

**BATTERY ACTIVATION**—Filling and charging a dry-charged battery before installation.

**BATTERY CABLES**—The heavy wires connecting the battery to the electrical system of the vehicle.

**BATTERY CAPACITY**—The rating of the current output of a battery.

**BATTERY CHARGE CONDITION**—The state of the battery plates and electrolyte.

**BATTERY CHARGER**—A device for restoring a battery to a proper electrical charge.

**BATTERY DRAIN TEST**—A method of checking for unusual current draw with the ignition key off.

**BATTERY LEAKAGE TEST**—A check to determine if current is discharging across the top of the battery case.

**BATTERY LOAD TEST**—A test for battery capacity, made under full electrical load.

**BATTERY TERMINAL TEST**—A test for good contact between the cables and terminals.

**BATTERY VOLTAGE**—For batteries used in modern vehicles, 12.3 volts.

**BATTERY VOLTAGE TEST**—A check of the battery charge with a voltmeter.

**BEARING NOISE**—A constant whir or humming sound due to damage or wear of bearings in the carrier or axle assemblies.

**BELTED BIAS TIRE**—A bias-belted tire with extra belts added beneath the tread area.

**BELTS**—Fabric made of steel or other material that is placed between body plies and tread.

**BENCH BLEED**—Method of filling and hand pumping a master cylinder before installation to remove trapped air.

**BIAS PLY TIRE**—One with plies running at an angle from bead to bead.

**BLEEDER SCREW**—Fitting on the top of the brake caliper that allows air to be bled from the system.

**BLEEDING**—Process of removing any trapped air from a hydraulic system.

**BRAKE BOOSTER**—Component operated by vacuum or power steering system to decrease braking effort needed.

**BRAKE LINES**—Metal tubing and rubber hoses connecting the master cylinder to the wheel brake assemblies.

**BRAKE PADS**—Replaceable friction surfaces mounted on the caliper of a disc brake system.

**BRAKE PEDAL ASSEMBLY**—Foot lever for operating the brake system.

**BRAKE PEDAL VIBRATION**—Pulsing movement of the brake pedal, usually caused by out-of-round brake drum or warped rotor.

**BRAKE SHOES**—Curved, replaceable friction surfaces used with drum-type brakes.

**BRAKE SYSTEM**—Components that are used to stop a vehicle.

**BRAKE SYSTEM FLUSHING**—Removal of all old fluid by pressure bleeding, then replacing it with fresh fluid.

**BRAKE WARNING LIGHT**—Dashboard indicator that warns of low brake system hydraulic pressure.

**BRAKING RATIO**—Comparison of front wheel to rear wheel braking effort.

**BRAKE-AWAY TORQUE**—The amount of torque required to make one axle rotate the clutches in a limited-slip differential.

**BRUSHES**—Sliding electrical contacts that ride on the slip rings of a generator.

**BURNED FLUID**—A condition caused by overheating due to slippage of the transmission bands.

**CALIPER**—A disc brake assembly that holds the brake pads and the wheel cylinder.

**CAMBER**—The inward or outward tilt of a wheel assembly.

**CASE BEARING PRELOAD**—The amount of force pushing the differential bearing together.

**CASTER**—The forward or backward tilt of the steering knuckle.

**CASTER-CAMBER GAUGE**—An instrument with bubbles that indicate the degree of tilt.

**CELL**—Electrical energy storage device, consisting of negative and positive plates immersed in a conductive fluid (electrolyte).

**CELL VOLTAGE TEST**—A check of individual battery cells for correct charge.



- CENTER SUPPORT BEARING**—A ball or roller bearing unit that supports the middle of a two-piece drive shaft.
- CHARGE INDICATORS**—Dash-mounted warning light, voltmeter, or ammeter used to show charging system status.
- CHARGING**—Current flowing into a battery from an alternator.
- CHARGING SYSTEM**—One that uses an alternator to replace the electrical energy drawn from the battery during starting.
- CHARGING SYSTEM OUTPUT TEST**—A measurement of current and voltage output of the charging system under load.
- CHARGING VOLTAGE**—Alternator output that is higher than battery voltage, between 13 to 15 volts.
- CHASSIS**—The frame and other parts of a vehicle, other than the body.
- CIRCUIT RESISTANCE TEST**—Measurements of resistance in the insulated and ground circuits of the system.
- CLUTCH**—A device that allows the operator to engage or disengage the engine and transmission.
- CLUTCH ADJUSTMENT**—A process of setting the correct amount of free play in the release mechanism.
- CLUTCH CABLE**—A simple mechanical arrangement that uses a cable to transmit clutch pedal movement to the clutch fork.
- CLUTCH CHATTER**—A condition in which the clutch severely vibrates as the vehicle accelerates.
- CLUTCH DISC**—A disc that is splined to the transmission input shaft and pressed against the face of the flywheel.
- CLUTCH FORK**—A lever that forces the throw-out (release) bearing into the pressure plate of the clutch.
- CLUTCH LINING**—Frictional material riveted to the face of the clutch disc.
- CLUTCH LINKAGE**—A mechanical arrangement of levers and rods that transmits force from the clutch pedal to the clutch fork.
- CLUTCH PEDAL FREE PLAY**—The distance the clutch pedal moves before the throw-out bearing acts on the pressure plate.
- CLUTCH RELEASE MECHANISM**—A cable or linkage permitting the operator to disengage the clutch with the foot pedal.
- CLUTCH SLIPPAGE**—A condition in which engine rpm increase without increase in the vehicle road speed.
- CLUTCH START SWITCH**—A safety switch that prevents the starting motor from operating until the clutch is disengaged.
- COIL**—A transformer used to step-up the battery voltage (by induction) to the high voltage required to fire the spark plugs.
- COIL SPRING COMPRESSOR**—A tool used to compress a spring for removal or installation on a vehicle safely.
- COIL WIRE**—A conductor carrying high voltage from the coil to the distributor.
- COLD CRANKING RATING**—The amount of current a battery can deliver for 30 seconds at 0°F.
- COMBINATION VALVE**—One valve that functions as a metering valve, proportioning valve, and a brake light warning switch.
- COMMUTATOR**—Sliding electrical connection between the motor winding and brushes.
- COMMUTATOR END FRAME**—The end housing on a motor that holds the brushes, brush springs, and shaft bushing.
- COMPUTER**—Electronic device used to control many systems of modern vehicles.
- COMPUTER-COIL IGNITION**—A distributorless ignition system using sensors, a control unit, and multiple ignition coils.
- COMPUTER VOLTAGE REGULATOR**—A device that provides a smooth dc voltage for circuits and devices controlled by the computer.
- CONDENSER**—An electrical component in contact point of distributors that prevents arcing as points that open and close.
- CONSTANT VELOCITY U-JOINT**—One that uses two cross-and-roller joints connected by a centering socket and center yoke.
- CONTACT PATTERN**—The area of a gear tooth where the matching gear tooth physically contacts it.

**CONTACT POINT REGULATOR**—An older type regulator that has been replaced by the electronic type.

**CONTACT POINTS**—A spring-loaded electrical "make/break" switch contacts.

**CONTROL ARM BUSHING**—A sleeve that allows the control arm to swing up and down.

**CONTROL ARMS**—Movable lever arm that forms part of the suspension system of the vehicle.

**CONVERTER HOUSING**—Case containing the fluid coupling (torque converter) used with an automatic transmission.

**CURB HEIGHT**—Distance from a given point on the vehicle to the ground.

**CURB WEIGHT**—Weight of the vehicle with a full gas tank and no passengers or cargo.

**CURRENT**—The flow of electrons through a conductor.

**CUSHIONING SPRINGS**—Flat springs under the friction material on the clutch disc that helps smooth the clutch engagement.

**CV**—Constant velocity.

**DC**—Direct current.

**DC GENERATOR**—A device that produces direct current.

**DEAD AXLE**—A solid, straight rear axle on a front-wheel drive vehicle.

**DEAD BATTERY**—One that has become completely discharged.

**DIAGONAL-BRAKE SYSTEM**—A brake system with separate hydraulic circuits connecting diagonal wheels together (RF to LR and LF to RR).

**DIAGRAMS**—Drawings that are used to show wiring, vacuum, or hydraulic systems.

**DIAPHRAGM SPRING CLUTCH**—A clutch that uses a single diaphragm spring, rather than several coil springs, to help release the clutch disc.

**DIFFERENTIAL**—An assembly of gears used to provide power to the rear axles and allow them to rotate at different speeds as necessary.

**DIFFERENTIAL CARRIER**—Component used to mount the differential assembly on the rear axle housing.

**DIFFERENTIAL CASE**—Case that holds the ring gear, spider gear, and inner ends of the axles.

**DIFFERENTIAL LUBRICANT**—A heavy oil used to reduce friction between differential components.

**DIFFERENTIAL YOKE**—Component that connects the rear universal of the drive line to the differential.

**DIMMER SWITCH**—Control for high beam and low beam headlamp functions.

**DIODE**—Electronic device that allows current flow in only one direction.

**DIODE TEST**—A check for open and shorted conditions in a diode, using an ohmmeter or special test equipment.

**DISC BRAKES**—Brakes using a caliper that clamps against a rotor for stopping.

**DISC BRAKE SERVICE**—Procedure involving worn pad replacement, caliper rebuilding, rotor surfacing, and system bleeding.

**DISC RESURFACING**—Machining the rotor surface to remove wear marks or correct runout.

**DISC RUNOUT**—Amount of side-to-side movement of the brake rotor.

**DISTILLED WATER**—Water that has been purified.

**DISTRIBUTOR CAP**—A plastic, insulating cover that encloses the distributor rotor and other components.

**DISTRIBUTOR POINT GAP**—Recommended distance between points when fully open.

**DISTRIBUTOR TESTED**—Test device used to check operation of an ignition system distributor.

**DOT NUMBER**—The Department of Transportation code that indicates the tire has passed a required safety test. Also identifies manufacturer, construction type, and other data.

**DRAGGING BRAKES**—Brakes that remain partially applied, even though the brake pedal is released.

**DRAGGING CLUTCH**—Failure of the friction disc to disengage from the flywheel fully, even though the clutch pedal is depressed.

**DRIVE CHAIN**—A chain used with some longitudinally mounted engines to transfer power from the engine crankshaft to the transaxle.

- DRIVE HOUSING**—Case surrounding the pinion gear on the starter motor.
- DRIVE LINE**—The parts that transfer power from the transmission to the drive wheels.
- DRIVE SHAFT**—Steel tube that transfers rotating motion from the transmission to the rear wheel of the vehicle.
- DRIVE SHAFT ANGLE**—The angle at which the drive line meets the differential or transmission.
- DRIVE SHAFT ASSEMBLY**—Components between the transmission and differential, including front and rear yokes, universal joints, and a drive shaft.
- DRIVE SHAFT BALANCE**—Equal weight distribution around the axis of the shaft.
- DRIVE SHAFT NOISE**—Sounds typically caused by worn U-joints, worn slip joints, or a faulty center support bearing.
- DRIVE SHAFT RUNOUT**—Lack of straightness due to being bent or because of U-joint wear.
- DRIVE SHAFT VIBRATION**—A rapid oscillation caused by a shaft imbalance or excessive shaft runout.
- DRIVING HUB**—Mounting for the wheel on the end of the axle.
- DRUM**—The housing that holds the parts of a clutch assembly for an automatic transmission.
- DRUM BRAKES**—System that forces brake shoes against the inside of a rotating drum to stop a vehicle.
- DRUM BRAKE SERVICE**—Process that involves dismounting, disassembling, cleaning, and replacing parts as necessary. Usually, shoes are replaced, wheel cylinders are replaced or rebuilt, and the drum is turned. System is then reassembled, bled, and tested.
- DRUM GRINDING**—A process done to remove hard spots on a brake drum.
- DRUM MAXIMUM DIAMETER**—Largest inside diameter allowed for safe operation of drum brakes.
- DRY CHARGED**—Battery is filled with electrolyte just before being installed in a vehicle.
- DUAL MASTER CYLINDER**—Brake system pump with two pistons and fluid reservoirs for safety.
- DWELL**—The amount of time distributor points remain closed between openings.
- DWELL METER**—One that measures point setting in degrees of distributor rotation.
- DYNAMIC IMBALANCE**—Tire imbalance that causes both up-and-down and side-to-side movement while rotating.
- ECM**—Electronic control module, another name for an automotive computer.
- ECU**—Electronic control unit, another name for an automotive computer.
- ELECTROLYTE**—Liquid that surrounds the plates of a battery and allows a free flow of electrons.
- ELECTRONIC ADVANCE**—A system that uses sensor input and the computer of the vehicle to control spark timing.
- ELECTRONIC IGNITION SYSTEM**—One that uses an electronic control circuit and distributor pickup coil.
- ELECTRONIC IGNITION TESTER**—Instrument use to identify source of ignition problems.
- ELECTRONIC MODULES**—Small computers in a vehicle, used for specific systems (such as anti-lock brakes).
- ELECTRONIC REGULATOR**—Solid-state regulator separate from the alternator.
- ELEMENT**—One of the cells that can be combined to form a battery.
- EMERGENCY BRAKE**—Mechanical means of applying the rear brakes.
- EXTENSION HOUSING**—A separate housing bolted to the transmission housing, containing the output shaft and rear oil seal.
- FACE**—Area of a gear tooth above the pitch line.
- FAST CHARGER**—One that provides a high current flow for quickly recharging a battery.
- FIELD FRAME**—Housing on a motor that holds the field coils.
- FIXED CALIPER**—Brake caliper rigidly mounted to the steering knuckle.
- FLOATING CALIPER**—Brake caliper mounted on two rubber bushings, allowing some movement.
- FORWARD BIAS**—Arrangement in which a diode acts as a conductor.

**FRAME**—The strong steel structure that supports the body of the vehicle.

**FRONT DRIVE AXLES**—Shafts that transfer power from the transaxle differential to the wheels of the vehicle.

**FULLY SYNCHRONIZED TRANSMISSION**—One in which all forward gears are equipped with synchronizers to allow downshifting while in motion.

**FUSE**—A device that interrupts current if a circuit is overloaded or a short occurs.

**FUSE BLOCK**—A boxlike unit that holds the fuses for the various electric circuits in a vehicle.

**FUSIBLE LINK**—A type of circuit protector in which a special wire melts to open the circuit when current is excessive.

**GEAR BACKLASH**—Small amount of clearance between meshing gear teeth.

**GEARBOX OVERHAUL**—The disassembly, cleaning, adjusting, and replacing parts as necessary.

**GEARBOX RATIO**—The relationship (number of turns) between the steering wheel and the sector gear.

**GEAR CLASH**—Noise that is heard when gears fail to mesh properly in a manual transmission.

**GEAR OIL**—A high viscosity oil (80W or 90W) used for manual transmissions and differentials.

**GEAR RATIO**—The number of rotations a driving gear must make while the driven gear is completing one revolution.

**GEAR REDUCTION**—The situation in which a small gear is used to drive a larger gear with an increase in torque as a result.

**GRABBING BRAKES**—Abrupt, hard application of brakes when the brake pedal is slightly depressed.

**GREASE SEAL**—Component that prevents lubricant leaking from the axle assembly into the steering knuckle or bearing support.

**GROUND**—The return path for current in an electrical circuit.

**GROWLER**—Testing device used to check armatures for shorts.

**HALL EFFECT**—A type of pickup used with many electronic ignition systems.

**HALOGEN LAMP**—One with a small, high intensity halogen lamp inside a conventional sealed housing.

**HARD STEERING**—Greater than normal effort required to turn the steering wheel.

**HARD TO SHIFT**—A manual transmission problem often caused by damaged or sticking linkage.

**HARSH SHIFTS**—Transmission changes gears in a jerky manner.

**HEADLAMP SYSTEM**—Components, such as battery, switches, fuses, and lamps that make up the headlamp lighting circuit.

**HEADLIGHT AIMER**—A device used to adjust headlights to specific positions.

**HEADLIGHT AIMING SCREEN**—Set of measured lines on a wall, used to adjust headlight aim.

**HEAT SINK**—A device for absorbing heat from one medium and transferring it to another.

**HORN RELAY**—A relay connected between the battery and the horn.

**HOTCHKISS DRIVE**—Open drive shaft that operates a rear axle assembly mounted on springs. The most common rear wheel drive type.

**HOT PLUG**—A spark plug with a long insulator tip, often used in older engines.

**HUB**—Mounting place for a vehicle wheel on the end of the axle or spindle.

**HYDRAULIC BRAKE BOOSTER**—Braking system booster actuated by hydraulic pressure from the power steering pump.

**HYDROMETER**—Tool used to test for specific gravity (and thus, battery charge).

**IDLER ARM**—A link that supports the tie rod and transmits steering motion to both wheels through the tie rod ends.

**IGNITION COIL**—Device used to produce the high voltage needed for ignition spark.

**IGNITION COMPUTER**—ECM that controls ignition timing, based on sensor input.

**IGNITION DISTRIBUTOR**—Component that directs coil voltage to each spark plug at the appropriate time.

**IGNITION RESISTOR**—A resistance connected into the primary circuit to reduce battery voltage to the coil during engine operation.

**IGNITION SWITCH**—The switch in the ignition system that opens and closes the ignition-coil primary circuit.

**IGNITION SYSTEM**—Components that produce a spark to ignite the air-fuel mixture in the engine.

**IGNITION TIMING**—How early or late the spark plugs fire in relation to piston position.

**IMPELLER**—Pump component with fanlike blades that spins inside a housing to move liquid.

**INCORRECT CAMBER**—Condition that produces wear on one side of the tire tread.

**INCORRECT TOE**—Condition that produces a feathered edge on the tire tread.

**INDEPENDENT SUSPENSION**—System that permits each wheel to move up and down without seriously affecting any other wheel.

**INFLATION PRESSURE**—The amount of air pressure that a tire can safely handle.

**INLET STUB SHAFT**—Section of front drive axle that is splined to differential gears. It is connected to the interconnecting shaft through a universal joint.

**INPUT**—The information provided to a computer by a sensor.

**INPUT SHAFT**—Metal shaft that transfers motion from the engine (via the clutch) to the transmission.

**INSULATED CURRENT RESISTANCE TEST**—Check of all parts between the battery positive and the starting motor for excess resistance.

**INSULATOR**—A material that resists the flow of electrons.

**INTEGRAL POWER STEERING**—A system in which the hydraulic piston is mounted inside the gearbox.

**INTEGRAL REGULATOR**—A regulator that is mounted in or on an alternator.

**INTEGRATED CIRCUIT**—A tiny "chip" of silicon, containing complete electronic circuits.

**INTERCONNECTING SHAFT**—Component of front drive axle that connects the inner and outer universal joints.

**JOUNCE BUMPER**—Rubber blocks that keep suspension parts from hitting the frame when the vehicle encounters large bumps or holes.

**JUMPS OUT OF GEAR**—A manual transmission problem in which the transmission will unexpectedly disengage and move into neutral.

**JUMP STARTING**—Providing current to a vehicle with a dead battery by connecting cables to the battery of an operating vehicle.

**KICKDOWN VALVE**—Component that causes an automatic transmission to shift down into a lower gear during fast acceleration.

**KNUCKLE**—A steering knuckle; a front suspension part that acts as a hinge to support a front wheel and permit it to be turned to steer the vehicle.

**LATERAL RUNOUT**—Side-to-side movement of a wheel or tire.

**LEAF SPRING**—Flat pieces of spring steel that are stacked and bound together. Normally used as a part of the rear suspension of the vehicle.

**LIMITED SLIP DIFFERENTIAL**—One that provides driving force to both rear wheels at all times.

**LIMITED SLIP DIFFERENTIAL CHATTER**—Sound made when turning a corner, caused by sticking and releasing of clutches in the differential.

**LINER**—Thin rubber layer bonded to plies and forming the inside surface of the tire.

**LOAD RATING**—The maximum amount of weight a tire can carry when inflated to the recommended pressure.

**LOCKED IN GEAR**—A manual transmission problem often caused by damaged or sticking linkage. Broken gear teeth can also be at fault.

**LOCKING HUB**—Components that transfer power from the driving axles to driving wheels on a four-wheel drive vehicle.

**LOCK-UP CONVERTER**—A variation of the fluid coupling with an internal friction clutch mechanism. It "locks up" in high gear, improving fuel economy.

**LOW BRAKE PEDAL**—Farther than normal brake pedal travel before braking begins.

**LUG NUT**—Large steel nuts, used to hold a wheel into the axle hub.

**LUG STUD**—Special bolts that are press-fit into the axle hub and accept lug nuts to mount the wheels of the vehicle.

**MACPHERSON STRUTE**—Suspension system that uses one control arm and one strut for each wheel.

**MAGNETIC FIELD**—Field of force generated around an electrical conductor.

**MAGNETIC SENSOR**—One that uses part movement (such as rotation) and induced current to produce a signal for a computer.

**MAIN COMPUTER**—The largest and most powerful microprocessor in a system of the vehicle.

**MAINTENANCE-FREE BATTERY**—One without removable filler caps that does not require periodic filling with water.

**MANUAL BLEEDING**—A method of system bleeding using only the master cylinder.

**MANUAL TRANSAXLE**—One with a manual (driver-operated) transmission.

**MANUAL VALVE**—In an automatic transmission, a valve actuated by the gearshift lever that routes oil pressure to the components required for the selected gear.

**MASTER CYLINDER**—Hydraulic piston type pump that develops pressure for the braking system.

**MILKY FLUID**—Condition caused by contamination of transmission fluid by engine coolant.

**MINIMUM DISC THICKNESS**—Thinnest rotor dimension allowed for proper and safe operation of disc brakes.

**MOVABLE POLE SHOE**—Device that uses a yoke lever to move the pinion gear into contact with the flywheel.

**MULTIPLE DISC CLUTCH**—One with several discs that can be used to drive planetary gearsets.

**MUSHY SHIFT**—Transmission changes too slowly.

**NEUTRAL SAFETY SWITCH**—Switch that prevents engaging the starter when the vehicle is in gear.

**NEUTRAL SAFETY SWITCH ADJUSTMENT**—Altering position of the switch to permit starting of the engine when gear selector is in the PARK position.

**NONDRIVING HUB**—One that rotates freely on spindles (axle ends).

**NONINDEPENDENT SUSPENSION**—System in which wheels are attached to each end of a solid axle.

**OHM'S LAW**—A simple formula for computing unknown electrical values when two values are known.

**ONE-WIRE CIRCUIT**—One that uses the vehicle frame as a return wire to the power source.

**OPEN CIRCUIT**—Electrical circuit with a gap or break in continuity so that current cannot flow.

**OPEN LOOP**—Control system using preset values in the computer to operate the engine.

**OUTBOARD CV-JOINT**—The outer universal joint on a front-wheel drive vehicle.

**OUTER STUB SHAFT**—In a front-wheel drive vehicle, the short shaft connecting outer universal joint and the front-wheel hub.

**OUTPUT**—The signal sent by a computer as a result of processing inputs it has received.

**OUTPUT SHAFT**—Transmission shaft on which the output gears are mounted.

**OUTPUT SHAFT GEARS**—Gears that turn the output shaft of a manual transmission.

**OVERDRIVE RATIO**—The situation in which a large gear is used to drive a smaller gear with an increase in speed as a result.

**OVERRUNNING CLUTCH**—Device that locks a pinion gear in one direction and releases it in the other.

**PACKING WHEEL BEARINGS**—Filling the bearing shells with grease to prevent excessive wear.

**PARKING PAWL**—A latch that locks the transmission so that the vehicle will not roll when the selector lever is in the PARK position.

**PEDAL FREE PLAY**—The amount of brake pedal movement before braking action begins to take place.

**PEDAL HEIGHT**—Distance of the brake pedal above the floor of the vehicle.

**PICKUP COIL**—Component that sends pulses to the control unit of an electronic ignition system as a result of trigger wheel action.

**PICKUP COIL AIR GAP**—The space between the pickup coil and the trigger wheel tooth.

**PILOT BEARING**—The bushing or bearing that supports the forward end of the transmission input shaft.

**PINION GEAR**—Differential gear turned by the drive line. It meshes with the ring gear. Also, a gearbox component that meshes with the rack gear or a small gear on a starter motor that engages a larger gear to rotate the engine flywheel.

**PINION GEAR BEARING PRELOAD**—Degree of tightness of bearings, adjusted by compressing a spacer or using shims.

**PINION GEAR CLEARANCE**—Distance between the pinion gear and drive end frame when the gear is engaged.

**PINION GEAR DEPTH**—The distance the pinion gear extends into the carrier to mesh with the ring gear.

**PINION PILOT BEARING**—A bearing used to support the pinion gear in the differential.

**PINION SHAFT**—Shaft holding the two differential idler (pinion) gears.

**PITCH LINE**—Imaginary line along the center of a gear tooth.

**PITMAN ARM**—Component that transfers gearbox motion to the steering linkage.

**PITMAN SHAFT OVER-CENTER ADJUSTMENT**—Adjustment of clearance between the sector gear and the ball nut teeth in a recirculating ball gearbox.

**PLANETARY GEARSET**—A set of gears consisting of several "planet" gears rotating around a central "sun" gear.

**PLUG GAP**—Distance between the center and side electrodes on a spark plug.

**PLUG HEAT RANGE**—Numeric indicator of how hot a spark the plug will develop.

**PLUG REACH**—Length of the threaded portion of a spark plug.

**PLY SEPARATION**—Pulling apart of tire plies as a result of overheating due to under inflation or other causes.

**POLE PIECE**—Magnetic component of a motor that keeps the armature rotating.

**POWER STEERING FLUID**—A hydraulic oil, usually automatic transmission fluid.

**POWER STEERING PRESSURE TEST**—Use of a pressure gauge to check pump and associated components for correct pressure.

**POWER STEERING PUMP**—Unit that provides the hydraulic pressure needed in a power steering system.

**POWER TRAIN**—Gearing system and other components used. to transfer energy from the engine to the wheels of the vehicle.

**PRESSURE BLEEDING**—A method of system bleeding using additional pressure supplied by an external air tank.

**PRESSURE PLATE**—Spring-loaded device that clamps the clutch disc against the flywheel.

**PRESSURE PLATE COVER**—Lid that bolts on the pressure plate to hold various components in place.

**PRESSURE PLATE FACE**—A large ring that contacts the friction disc as the clutch engages.

**PRESSURE PLATE RELEASE LEVERS**—Levers hinged inside the pressure plate that help move the pressure plate face away from the clutch disc and flywheel.

**PRIMARY AND SECONDARY SHOES**—Front and back shoes in a drum brake system. The secondary shoe has a larger surface area.

**PRIMARY CIRCUIT**—In an ignition system, all components are operating on battery (low) voltage.

**PRIMARY WIRE**—Small insulated conductor that carries battery or alternator voltage.

**PROPORTIONING VALVE**—Valve designed to equalize pressure at the wheel cylinders on vehicles with front disc and rear drum brakes.

**PULLING BRAKES**—Situation in which a vehicle veers to one side when the brakes are applied.

**QUICK CHARGE TEST**—A method of determining whether battery plates are sulfated (no longer able to hold a charge).

**RACK AND PINION STEERING GEAR**—A steering gear in which a pinion of the end of the steering shaft meshes with a rack of gear teeth on the major cross member of the steering linkage.

**RACK AND PINION STEERING GEAR ADJUSTMENT**—Tightening or loosening rack adjustment screw as needed for optimum steering.

**RADIAL RUNOUT**—Uneven rotation caused by differences in diameter.

**RADIAL TIRE**—One that has cord plies running straight across, from bead to bead. Additional stabilizer plies are placed beneath the tread.

**READING SPARK PLUGS**—Determining cause of a problem by examining condition of the spark plug.

**READING TIRES**—Identifying alignment, suspension, and other problems through the wear patterns on tire treads.

**REAR AXLE ASSEMBLY**—A combination of gears and axles converting rotary motion of the drive shaft to forward or backward motion of a vehicle.

**REAR AXLE RATIO**—The relationship between the numbers of teeth on the pinion gear and ring gear. Ratio affects acceleration, pulling power, and fuel economy.

**REAR DRIVE AXLE ASSEMBLY**—Differential, axles, and other components transferring power from the drive line to the rear wheels.

**REAR DRIVE AXLES**—The components that transmit power from the differential gears to the wheels.

**RECIRCULATING BALL**—Most common type of gearbox used with linkage steering system.

**RECTIFIED**—Term used to describe ac current that has been changed to dc.

**REDUCTION STARTER**—One that uses extra gears to increase the torque applied to the flywheel gear.

**REGULATOR BYPASS TEST**—Test that connects full battery voltage to the alternator field, leaving the regulator out of the circuit.

**REGULATOR VOLTAGE TEST**—Test the charging system under low output, low load conditions.

**RELAY** —Electrically operated switch.

**RESERVE CAPACITY RATING**—The amount of time a battery will continue to provide as acceptable current flow when not being recharged by the alternator.

**RESERVE DISTANCE**—Amount of travel remaining between pedal and floor when the brakes are applied.

**RESISTANCE**—Opposition to current flow.

**RESISTANCE PLUG WIRE**—Special type of spark plug wire that eliminates most radio interference.

**RETRACTING AND HOLD-DOWN SPRINGS**—Springs that pull the shoes away from the brake drum surface when the pedal is released.

**REVERSE BIAS**—Arrangement in which a diode acts as an insulator.

**REVERSE IDLER SHAFT**—Shaft in a manual transmission on which the reverse idler gear is mounted.

**REVERSE POLARITY**—Accidental backward connection of primary wires.

**RING AND PINION BACKLASH**—The amount of space between the meshing gear teeth.

**RING AND PINION NOISE**—Whining or howling sounds that change pitch with speed change, usually cause by wear or damage to differential components.

**RING GEAR**—Large gear in the differential that is driven by the pinion gear and, in turn, drives the spider gears.

**RING GEAR RUNOUT**—The amount of wobble that occurs as the gear rotates.

**ROLLING RESISTANCE**—A measure of the amount of resistance that is generated as a tire rolls on the road surface.

**ROTOR**—A rotating contact inside the distributor that routes electrical pulses from the coil to the spark plugs. Also, the metal disc against which brake pads are forced to stop a vehicle.



**ROTOR CURRENT TEST**—Method used to check alternator windings for an internal short.

**ROTOR WINDING OPEN**—An open (broken) winding in an alternator rotor.

**ROTOR WINDING SHORT**—A short-to-ground fault in an alternator rotor.

**RZEPPA CV-JOINT**—Ball-and-cage type constant velocity joint used on front-wheel drive vehicles.

**SAFETY RIM**—Wheel designed with small ridges that holds a tire in place if a blowout or flat occurs.

**SECONDARY CIRCUIT**—In an ignition circuit, all components are operating on coil (high) voltage.

**SECONDARY WIRE**—Wire used in a vehicle ignition system. It carries high voltage from the coil to the spark plugs.

**SECONDARY WIRE RESISTANCE**—A test performed to check condition of a spark plug or coil wire.

**SECTOR SHAFT**—Output gear in a recirculating ball gearbox.

**SEMICONDUCTOR**—Substance that acts as an insulator or conductor, depending upon conditions.

**SENSOR**—Device that monitors and reports a condition to the vehicle computer.

**SENSOR ROTOR**—A toothed wheel that operates at the same rpm as the vehicle wheel.

**SEPARATOR**—An insulating material placed between the plates of a battery.

**SERVO**—Piston that operates a band in an automatic transmission.

**SERVO ACTION**—Situation in which the primary shoe of a drum brake system helps apply the secondary shoe.

**SHAFT RUNOUT**—Wear or damage (bending), causing a shaft not to run true around its axis.

**SHIFT FORK**—Device that physically moves the synchronizer and gear together as a result of shift lever movement.

**SHIFT LEVER**—The handle operated by the vehicle operator to shift from gear to gear manually.

**SHIFT LINKAGE ADJUSTMENT**—Making sure the transmission linkage positions match the gear selector positions.

**SHIFT RAIL**—A manual transmission linkage that is contained within the transmission case.

**SHOCK ABSORBER**—Device that uses air or hydraulic pressure to dampen up-and-down motion of a vehicle.

**SHORT CIRCUIT**—Excess current flow that occurs when a conductor touches ground.

**SHORTED CONDENSER**—One with a direct electrical connection to ground.

**SIDEWALL**—Portion of a tire between the tread and bead.

**SIMPLE CIRCUIT**—One consisting of a power source, a load, and conductors.

**SLOW CHARGER**—One that feeds a small current into the battery over a long period of time.

**SOLENOID ACTUATOR**—One with a moving metal core that is actuated by an induced magnetic field.

**SPARK PLUG**—Devices that emit an electrical arc at the tip to ignite the air-fuel mixture in an engine cylinder.

**SPARK TEST**—Check of the spark intensity (brightness and length of arc).

**SPECIFIC GRAVITY**—Weight or density of a liquid.

**SPIDER GEARS**—Idler and axle gears in the differential that drive the rear axles of a vehicle.

**SPINDLE**—Stationary shaft used to support rotating wheel assembly on nondriving wheels.

**SPONGY BRAKES**—Braking system that is "soft" feeling, usually as a result of air trapped in the hydraulic system.

**SPRING RATE**—The stiffness or tension; amount of weight required to compress or bend a spring.

**STARTER CURRENT DRAW TEST**—Starting test that establishes the number of amps used by the starting system.

**STARTER GROUND CIRCUIT RESISTANCE TEST**—Check of all parts between the battery negative and the starting motor.

**STARTER MOUNTED SOLENOID**—One with a plunger that moves to engage the pinion gear with the flywheel gear.

- STARTER RELAY**—Device that uses a small current flow from the ignition switch to control a larger current flow to the starter solenoid.
- STARTER SOLENOID**—A high current relay that energizes the starter motor.
- STARTING HEADLIGHT TEST**—Starting test conducted with the headlights turned on to provide a load on the battery.
- STARTING SYSTEM**—Electric motor and other components used to rotate the engine until it starts.
- STATIC IMBALANCE**—Lack of balance that causes a wheel to vibrate up and down as it rolls.
- STATOR**—The stationary magnetic field in a generator. Also, component of a torque converter that improves oil circulation and thus, torque.
- STATOR TEST**—Ohmmeter check for open and shorted windings in the stator.
- STEERING AXIS INCLINATION**—Angle formed by the inward tilt of the ball joints, kingpin, or struts.
- STEERING COLUMN**—Assembly consisting of the steering wheel, steering shaft, ignition key mechanism, and associated parts.
- STEERING GEARBOX**—Gear assembly that turns rotary motion into linear (straight line) left-right motion.
- STEERING KNUCKLE**—Component that provides support for the wheel spindle or bearings surrounding an axle.
- STEERING LINKAGE**—Components connecting the steering gearbox to the steering knuckles.
- STEERING SHAFT**—Component that transfers turning motion from the steering wheel to the steering gearbox.
- STEERING SYSTEM**—The components that allow the operator to change direction of a vehicle.
- STEERING WHEEL PLAY**—Excessive movement of the steering wheel without causing any front-wheel movement.
- STIFF CLUTCH PEDAL**—A condition caused by binding or other restriction in the clutch mechanism, making the pedal hard to depress.
- STRUT ASSEMBLY**—Suspension component combining shock absorber, coil spring, and upper damper unit. It replaces the upper control arm.
- STRUT CARTRIDGE**—Replaceable shock absorber unit on a MacPherson strut.
- STRUT ROD**—Rod that fastens to the control arm and frame to keep the control arm properly oriented.
- SUSPENSION SYSTEM**—Components that let the wheels move up and down without body movement.
- SWAY BAR**—A stabilizer that keeps the vehicle body from leaning excessively in turns.
- SYNCHRONIZER**—Assembly of hub, sleeve, and other components that locks the selected output gear to the output shaft to transmit power. It permits meshing of gears with grinding.
- TERMINALS**—The positive and negative posts or threaded connectors on a battery.
- THROW-OUT BEARING**—Bearing that decreases friction between the clutch fork and pressure plate.
- TIE ROD**—Connectors between rack ends and steering knuckles.
- TIMING ADVANCE**—Making the spark plug fire sooner in the compression stroke.
- TIRE**—The casing-and-tread assembly that is mounted on a vehicle to provide pneumatically cushioned contact and traction with the road.
- TIRE BEAD**—Wire ring encased in rubber that helps hold the tire sidewall against the rim.
- TIRE IMPACT DAMAGE**—Punctures, cuts, or tears caused by running over debris in the road.
- TIRE MARKINGS**—Information shown on the sidewall to indicate inflation pressure, load-carrying ability, size, and other data.
- TIRE PLY**—Layer of fabric or other material that forms the carcass or body of the tire.
- TIRE ROTATION**—Moving tires to different wheels periodically to even out wear.
- TIRE WEAR ANGLE**—Usually, a reference to camber because tilting the wheels puts more load on one side of the tire tread than on the other side.
- TIRE WEAR PATTERN**—Areas of tread that are worn off, which can provide information on causes of wear.
- TOE**—Degree to which opposing wheels are on converging or diverging lines (not parallel). Also, the narrow part of a gear tooth.

**TOE-OUT ON TURNS**—Steering feature that turns the inside wheel more sharply than the outside wheel.

**TORQUE CONVERTER**—Fluid coupling that acts as a clutch on an automatic transmission.

**TORQUE MULTIPLICATION**—Variation in torque achieved by turning the impeller of a torque converter faster than the turbine.

**TORQUE TUBE**—A solid steel drive shaft enclosed in a hollow tube with a single swivel joint at the front.

**TORSION BAR**—Spring steel rod that operates by twisting and untwisting.

**TORSION SPRINGS**—Small coil springs that help absorb the shock and vibration that occur when the clutch engages.

**TRACKING**—The position or direction of the front wheels in relation to the rear wheels.

**TRACK ROD**—Metal rod used to prevent axle side-to-side movement when cornering.

**TRAM GAUGE**—Instrument used to compare distances between the front and rear set of tires for toe adjustment.

**TRANSAXLE**—A combination of transmission and differential in one case, used on front-wheel drive vehicles.

**TRANSAXLE DIFFERENTIAL**—Transaxle assembly that transfers torque to the driving wheels and allows them to rotate at different speeds.

**TRANSAXLE GEARBOX**—The transmission section of the transaxle, housing the forward and reverse gears.

**TRANSAXLE INPUT SHAFT**—Main shaft that turns the gears in a transaxle.

**TRANSAXLE OUTPUT SHAFT**—Shaft that transfers power to the ring and pinion gears of the differential.

**TRANSFER CASE**—A power takeoff unit that sends power to both the front and rear axle assemblies on a multiwheel drive vehicle.

**TRANSISTOR**—Tiny electronic component that functions as a switch, but has no moving parts.

**TRANSMISSION CASE**—Metal housing surrounding and supporting the transmission.

**TRANSMISSION COOLER**—A small separate radiator, used to cool transmission oil in vehicles pulling heavy loads.

**TRANSMISSION LINKAGE**—System that connects the shift lever with the transmission shift forks.

**TRANSMISSION OIL COOLER**—Small tank within the radiator, used to regulate transmission fluid temperature.

**TRIGGER WHEEL**—Rotating component with one tooth for each cylinder.

**TRIPOD CV-JOINT**—Constant velocity joint used on front-wheel drive vehicles, consisting of a spider and ball arrangement inside a housing.

**TUBELESS**—A tire that does not have a separate inner tube to hold air.

**TURBINE**—The driven fan in a torque converter.

**TURNING**—Tem, usually used for machining a brake drum or rotor, since this process is carried out on a lathe.

**TURNING RADIUS GAUGE**—Instruments that measure how many degrees left or right the front wheels are turned.

**U-JOINT ALIGNMENT MARKS**—Scribed marks made on U-joint components before disassembly, allowing the joint components to be reassembled in the same positions to avoid possible imbalance and vibration.

**UNDER INFLATION**—Operating tires with a lower than recommended air pressure.

**UNIBODY**—A vehicle structure in which the body and frame are one unit.

**UNIVERSAL JOINT**—A flex joint allowing limited up-and-down and side-to-side movement.

**UNSPRUNG WEIGHT**—The weight of the vehicle parts that are not supported by the springs, such as the wheels.

**VACUUM ADVANCE**—A mechanism on the ignition distributor that uses intake manifold vacuum to advance the timing of the spark to the spark plugs.

**VACUUM MODULATOR**—A device that modulates, or changes, the main-line hydraulic pressure in an automatic transmission to meet changing engine loads.

**VALVE BODY**—Housing that contains most of the valves used in operation of an automatic transmission.

**VALVE CORE**—A threaded air valve that screws into place in a valve stem.

**VALVE STEM**—A rubber inflation tube with a threaded metal core that snaps into a hole on the rim of a wheel designed for tubeless tires.

**VALVE STEM CAP**—A cap placed over the end of the valve stem to prevent stem wear.

**VOLTAGE**—Electrical pressure that causes current flow.

**VOLTAGE DROP**—Reduction of the amount of current flowing in a circuit.

**VOLTAGE DROP TEST**—Starting system test that identifies parts showing high resistance.

**VOLTAGE REGULATOR**—Device used to control alternator output.

**WEAR BAR**—Solid bars of rubber across the tread that appears when a tire has worn to an unsafe limit.

**WET CHARGED**—Battery that is filled with electrolyte and fully charged at the factory.

**WHEEL ALIGNMENT**—Adjusting wheels of a vehicle to roll in a straight line.

**WHEEL BEARING**—Ball or roller bearing assemblies that reduce friction as wheels or axles rotate.

**WHEEL BRAKE ASSEMBLIES**—Components that use hydraulic pressure to apply friction for stopping a vehicle.

**WHEEL CYLINDER**—Hydraulic piston that actuates braking at each wheel.

**WHEEL HOP**—A bouncing or up-and-down movement.

**WHEEL SHIMMY**—A side-to-side movement caused by dynamic imbalance.

**WHEEL SPEED SENSORS**—Magnetic pickups to detect wheel speed (used on anti-lock braking systems).

**WHEEL WEIGHT**—Small pieces of lead that are clipped to the wheel rim to balance the wheel and tire combination.

**WINDING**—Loop or wire on a motor armature that generates a magnetic field.

**WIRING DIAGRAM**—Drawings that show relationships of components in an electrical circuit.

**WIRING HARNESS**—A group of primary wires enclosed in a protective plastic covering.

**WORM SHAFT**—Input gear in a recirculating ball gearbox.

## APPENDIX II

# REFERENCES USED TO DEVELOP THIS TRAMAN

### CONSTRUCTION MECHANIC, VOLUME 2, NAVEDTRA 11011

*Although the following references were current when this TRAMAN was published, their continued currency cannot be assured. When consulting these references, keep in mind that they may have been revised to reflect new technology or revised methods, practices, or procedures. You therefore need to ensure that you are studying the latest references.*

- 1988 C-K Pick-Up Truck, Service Manual*, Chevrolet Motor Division, General Motors Corporation, Detroit, MI, 1986.
- 1989 Medium/Heavy-Duty Truck, Shop Manual*, Ford Motor Company, Dearborn, MI, 1988.
- Duffy, James E., *Modern Automotive Technology*, Goodheart-Willcox Company Inc., South Holland, IL, 1994.
- Equipment Operator Basic*, NAVEDTRA 12535, Naval Education and Training Professional Development and Technology Center, Pensacola, FL, 1994.
- Fluid Power*, NAVEDTRA 12964, Naval Education and Training Professional Development and Technology Center, Pensacola, FL, 1990.
- Fundamental of Service, Electrical Systems*, 5th ed., Deere and Company, Moline, IL, 1984.
- Fundamental of Service, Hydraulics*. Deere & Company, Moline, IL, 1987.
- Fundamental of service, Power Trains*, Deere and Company, Moline, IL, 1984.
- Navy Electricity and Electronics Training Series (NEETS), *Introduction to Generators and Motors*, NAVEDTRA B72-05-00-94, Naval Education and Training Professional Development and Technology Center, Pensacola, FL, 1994.
- Navy Electricity and Electronics Training Series (NEETS) *Introduction to Matter, Energy, and Direct Current*, NAVEDTRA B72-01-00-94, Naval Education and Training Professional Development and Technology Center, Pensacola, FL, 1994.
- Nichols, Herbert L., Jr., *Heavy Equipment Repair*, McGraw-Hill, New York, 1989.
- Principles of Automotive Vehicles*, TM 9-8000, Department of the Army, Washington, DC, 1988.
- Rough Terrain Forklift Truck Service Manual*, Model M4KN (4,000 Pounds), J.I. Case Company, Racine, WI, 1987.

*Rough Terrain Forklift Truck Service Manual*, Model LK12000, Lift King Incorporated, Main Line Construction Equipment, Woodbridge, Ontario, 1991.

*Rubber Tired Loader Service Manual*, Model 520C, Dresser Industries, Libertyville, IL, 1990.

*Tractor, Full-Track Service Manual*, Model 1150E, J.I. Case Company, Racine, WI, 1986.

# INDEX

## A

Accumulators, 3-15  
Abnormal noises, 4-10  
Adjusting mechanism, 6-16  
Aiming headlights, 2-47  
Air brake system, 7-33  
Air cleaner servicing, 3-34  
Air compressor maintenance, 3-33  
Air-hydraulic-power cylinder (AIR PAK), 7-45  
Air hoses and fittings, 7-43  
Air tanks/reservoirs, 7-37  
Air-over-hydraulic brake operation, 7-46  
Air-over-hydraulic brake system, 7-44  
Aftercoolers, 3-33  
Alternators, 2-17  
Alternator construction, 2-17  
Alternator maintenance, 2-20  
Alternator operation, 2-19  
Alternator output control, 2-20  
Alternator testing, 2-21  
Amperage, 1-9  
Anti-lock brake system, 7-17  
Automatic transaxle, 4-42  
Automatic transmissions, 4-26  
Automatic transmission service, 4-40  
Automotive chassis and body, 8-1 - 8-58  
Automotive clutches and transmissions, 4-1 - 4-44  
Automotive clutches, 4-1  
Automotive electrical circuits, 2-1 - 2-64  
Automotive wiring, 2-59  
Auxiliary transmission, 4-20  
Axle bearing service, 5-26  
Axle housing, 5-23  
Axle seal service, 5-27

## B

Backup light system, 2-49  
Ball and Trunnion universal joints, 5-4  
Ball joint service, 8-13  
Ball joints, 8-6  
Ball sockets, 8-17  
Basic automotive electricity, 1-1 - 1-17  
Basic principles of electricity, 1-1  
Basic principles of hydraulics, 3-1

Basic principles of pneumatics, 3-29  
Battery capacity, 2-5  
Battery charging, 2-5  
Battery condition gauge, 2-51  
Battery construction, 2-3  
Battery maintenance, 2-7  
Battery ratings, 2-5  
Battery test, 2-9  
Bendix-Weiss (CV) joint, 5-6  
Belted bias tire, 8-30  
Bias-ply tire, 8-30  
Blackout lights, 2-48  
Body repair, 8-47  
Body tools, 8-48  
Boyle's law, 3-29  
Brake band, 4-33  
Brake chambers, 7-38  
Brake disc service, 7-31  
Brake pedal action, 7-25  
Brake shoe energization, 7-12  
Brake system bleeding, 7-31  
Brake system inspection, 7-25  
Brake system leaks, 7-25  
Brake switches and control valves, 7-16  
Brake valves, 7-38  
Brake warning light switch, 7-17  
Brakes, 7-1 - 7-48  
Braking ratio, 7-3  
Braking temperature, 7-2

## C

Cam and lever, 8-19  
Camber, 8-43  
Caster, 8-42  
Caster-camber gauge, 8-46  
Center link, 8-17  
Center support bearing service, 5-10  
Center support bearings, 5-7  
Centrifugal advance, 2-37  
Charging circuit, 2-2  
Charging system output test, 2-23  
Charging system test, 2-22  
Charles's law, 3-30  
Check valves, 7-42  
Checking brake assemblies, 7-25

Checking master cylinder fluid, 7-25  
Checking the fluid, 4-30  
Circuit breaker and fuses, 2-51  
Circuit configurations, 1-10  
Circuit failures, 1-12  
Circuit resistance test, 2-23  
Cleaning and flushing the system, 3-26  
Clutch adjustment, 3-7  
Clutch cable adjustment, 4-7  
Clutch construction, 4-3  
Clutch disc, 4-6  
Clutch fork, 4-4  
Clutch housing, 4-4  
Clutch linkage adjustment, 4-7  
Clutch operation, 4-6  
Clutch overhaul, 4-11  
Clutch pack limited slip differential, 5-16  
Clutch release mechanism, 4-3  
Clutch start switch, 4-7  
Clutch troubleshooting, 4-8  
Clutches and bands, 4-31  
Combination valve, 7-17  
Combined quick-release valve, 7-40  
Composition of matter, 1-1  
Composition of electricity, 1-2  
Compressed air, 3-30  
Compressibility and expansion of gas, 3-29  
Compressor design, 3-31  
Compressor, unloader assembly, 7-33  
Computerized advance, 2-37  
Computing force, pressure, and area, 3-1  
Conductors and insulators, 1-3  
Cone clutch limited slip differential, 5-18  
Connectors and fittings, 3-30  
Constant mesh transmission, 4-17  
Constant velocity joint service, 5-10  
Constant velocity (CV) joints, 5-3  
Construction equipment drive trains, 6-1 - 6-32  
Contact point ignition system, 2-35  
Contact points ignition system, 2-35  
Contamination control, 3-35  
Control arms and bushings, 8-6  
Control valves, 3-7  
Conventional transfer case, 5-28  
Corrosion control, 8-54  
Cross and Roller universal joints, 5-3  
Cylinders, 3-13

## D

Demister or separator element, 3-35  
Differential action, 5-14  
Differential carrier, 5-11  
Differential case, 5-11  
Differential construction, 5-11  
Differential lubricant service, 5-19  
Differential adjustment, 5-20  
Differential removal and reassembly, 5-19  
Differential service and maintenance, 5-18  
Differentials, 5-11  
Dimmer switch, 2-46  
Diodes, 1-6  
Direct-current (dc) generator, 2-11  
Disadvantages of drum brakes, 7-12  
Disc brake assembly, 7-15  
Disc brake pad replacement, 7-30  
Disc brake types, 7-15  
Disc brakes, 7-14  
Distributor service, 2-40  
Double Cardan universal joints, 5-4  
Double reduction final drive, 5-13  
Dragging, 4-10  
Drive axles, 5-23  
Drive line assembly, 5-1  
Drive line maintenance, 5-7  
Drive lines, differentials, drive axles, and power train accessories, 5-1 - 5-35  
Drive shaft inspection, 5-8  
Drive shaft noises, 5-8  
Drive shafts, 5-2  
Drive trains, 6-1  
Driving straight ahead, 5-14  
Driving wheel assembly, 8-36  
Drop center wheel, 8-34  
Drum brake assemblies, 7-7  
Drum brakes, 7-7

## E

Electric current, 1-3  
Electrical measurements, 1-9  
Electric speedometers and tachometers, 2-57  
Electromagnetic induction, 1-15  
Electromagnetism, 1-13  
Electron theory of electricity, 1-2  
Electronic ignition system, 2-35  
Electronic ignition system components, 2-36



Electronic ignition system operation, 2-36  
Electronic speedometers, 2-57  
Electronic tachometers, 2-57  
Emergency light system, 2-50  
Epoxy fillers, 8-54  
Extension housing, 4-13  
External cylinder (linkage type), 8-23

## **F**

Fifth gear, 4-20  
Final drive, 5-12  
First gear, 4-18  
Fluid replacement, 4-40  
Flywheel, 4-6  
Fourth gear, 4-20  
Frame maintenance, 8-3  
Frames, 8-1  
Front bearing hub, 4-13  
Front drive axle, 5-25  
Front-wheel drive axle, 5-26  
Fuel gauge, 2-52  
Full-floating axle, 5-24

## **G**

Generators, 2-11  
Generator maintenance, 2-14  
Generator repair, 2-14  
Governor valve, 4-38  
Grabbing, 4-9

## **H**

Hall effect sensor, 2-36  
Hard steering, 8-29  
Headlight switch, 2-45  
Headlights, 2-45  
Heavy-duty compressors, 3-31  
Horn, 2-58  
Hydraulic boosters, 7-22  
Hydraulic brake systems, 7-1  
Hydraulic clutch adjustment, 4-8  
Hydraulic and pneumatic systems, 3-1 - 3-37  
Hydraulic systems, 3-1  
Hydraulic system components, 3-4  
Hydraulic system maintenance, 3-25  
Hydraulic system, brake lines and hoses, 7-5  
Hydraulic system, master cylinder, 7-3  
Hydraulic system, wheel cylinders, 7-5

Hydrostatic drive operation, 6-9  
Hydrostatic drive train, 6-7  
Hypoid gear, 5-12

## **I**

Identification marking, 8-54  
Idler arm, 8-17  
Ignition circuit components, 2-32  
Ignition circuit, 2-31  
Ignition coil, 2-32  
Ignition distributor, 2-33  
Ignition switch, 2-32  
Ignition system maintenance, 2-38  
Ignition timing, 2-42  
Ignition timing devices, 2-36  
Incompressibility of liquids, 3-2  
Inspection of track, 6-17  
Instruments, gauges, and accessories, 2-5  
Integral piston (linkage type), 8-22  
Integrated frame and body, 8-2  
Intercoolers, 3-33

## **J**

Joint, Bendix-Weiss, 5-6  
Joint, constant velocity, 5-4  
Joint, Rzeppa, 5-4  
Joint, slip yoke, 5-1  
Joint, tripod, 5-7

## **K**

Kickdown valve, 4-39  
Kinetic theory of gases, 3-29

## **L**

Lamps, 2-44  
Leaf spring, 8-10  
Limited slip differentials, 5-14  
Linkage and band adjustment, 4-40  
Load index and speed ratings, 8-32  
Low-air-pressure warning indicator, 7-43  
Lug nuts, studs, and bolts, 8-34

## **M**

Magnetism, 1-12  
Main oil filter servicing, 3-34

Maintenance of hydrostatic drives, 6-12  
Manual bleeding, 7-31  
Manual steering systems, 8-18  
Manual steering system service, 8-25  
Manual transaxles, 4-42  
Manual transmissions, 4-13  
Manual valve, 4-36  
Mechanical drive train, 6-1  
Mechanical speedometers, 2-56  
Mechanical tachometers, 2-56  
Metering valve, 7-17  
Motors, 3-18  
Multiple-disc clutch, 4-31  
Multiplication of forces, 3-3

## N

Neutral safety switch, 2-29  
Nondriving wheel assembly, 8-35

## O

OHM'S Law, 1-9  
Oil and filter changes, 3-26  
One- and two-wire circuits, 2-59  
Overrunning clutch, 1-32

## P

Painting, 8-53  
Painting, preparing the surface, 8-52  
Parking brakes, 7-22  
Pascal's law, 3-2  
Pedal pulsation, 4-10  
Petroleum-based fluids, 3-4  
Pilot bearing, 4-6  
Pinion gear, 5-11  
Pitman arm, 8-17  
Pivot brakes, 6-7  
Placing new batteries in service, 2-6  
Planetary gear sets, 4-30, 6-4  
Planetary steering, 6-5  
Pneumatic gases, 3-30  
Pneumatic systems, 3-29  
Positive traction transfer case, 5-31  
Potential hazards, 3-35  
Power brakes, 7-19  
Power flow, 4-18  
Power rack and pinion, 8-23  
Power shift transmission, 6-1

Power steering systems, 8-21  
Power steering system service, 8-27  
Power takeoffs, 5-32  
Pressure and force, 3-1  
Pressure bleeding, 7-32  
Pressure-control system, 3-33  
Pressure gauge, 2-54  
Pressure plate, 4-1  
Pressure regulator, 4-35  
Preventing leaks, 3-26  
Preventing overheating, 3-28  
Primary and secondary circuits, 2-31  
Principles of braking, 7-1  
Proportioning valve, 7-17  
Pump, 4-35  
Pumps, 3-6

## Q

Qualities, 3-30  
Quick-release valve, 7-40

## R

Rack and pinion, 8-20  
Radial ply tire, 8-30  
Rear axle service, 5-26  
Rear drive axle, 5-24  
Receiver tank, 3-33  
Recoil spring, 6-17  
Refilling the transmission, 4-41  
Regulation of generator output, 2-13  
Regulator bypass test, 2-23  
Regulator voltage test, 2-23  
Relay emergency valve, 7-41  
Release bearing, 4-4  
Removing dents, 8-49  
Replacing brake shoe linings, 7-27  
Replacing sheet metal, 8-51  
Reservoir, 3-5  
Resistance, 1-9  
Reverse gear, 4-18  
Ring and pinion backlash, 5-21  
Ring and pinion tooth contact pattern, 5-21  
Ring gear, 5-11  
Rotating tires, 8-37  
Rzeppa joint, 5-5

## S

Safety precautions, 3-35  
Safety wheel, 8-34  
Sealing materials and devices, 3-23  
Second gear, 4-20  
Semiconductors, 1-4  
Semidrop center wheel, 8-34  
Servicing air brakes, 7-44  
Servicing brake drums, 7-29  
Servicing caliper assemblies, 7-30  
Servicing disc brakes, 7-29  
Servicing drum brakes, 7-26  
Servicing master cylinders, 7-26  
Servicing wheel cylinders, 7-27  
Shift linkage and levers, 4-16  
Shift valves, 4-39  
Shock absorber service, 8-15  
Shock absorbers and struts, 8-6  
Shop repairs, 6-17  
Slack adjusters, 7-38  
Slipping, 4-9  
Slip yoke (joint), 5-1  
Spark plug, 2-33  
Spark plugs and plug wires, 2-38  
Spark plug heat range and reach, 2-34  
Spark plug wires, 2-34  
Speedometers and tachometers, 2-56  
Spider gears, 5-12  
Spiral bevel gear, 5-12  
Spring terminology, 8-9  
Stabilizer bar, 8-9  
Starting circuit, 2-25  
Starting circuit maintenance, 2-30  
Starting motor, 2-25  
Starting motor circuit tests, 2-30  
Starting motor construction, 2-25  
Starting motor current draw test, 2-30  
Starting motor voltage drop tests, 2-30  
Steering axis inclination, 8-44  
Steering geometry, 8-41  
Steering linkage, 8-17  
Steering linkage service, 8-25  
Steering system, 8-16  
Steering system maintenance, 8-25  
Steering system noises, 8-29  
Steering ratio, 8-18  
Stoplight switch, 7-17  
Stoplight switches, 7-43

Stoplight system, 2-50  
Storage battery, 2-2  
Strainers and filters, 3-6  
Strut service, 8-15  
Suspension bushing service, 8-13  
Suspension system components, 8-6  
Suspensions systems, 8-4  
Suspension system service, 8-13  
Suspension system springs, 8-9  
Synchromesh transmission, 4-18  
Synchronizers, 4-15  
Synthetic fire-resistant fluids, 3-4  
System switches and indicators, 7-43

## T

Temperature gauge, 2-55  
Third gear, 4-20  
Tie-rod assemblies, 8-18  
Tire and wheel-bearing noise, 8-41  
Tire construction, 8-30  
Tire grades, 8-32  
Tire impact damage, 8-40  
Tire inflation problems, 8-40  
Tire repair, 8-36  
Tire size and markings, 8-31  
Tire wear patterns, 8-40  
Tire vibration problems, 8-41  
Tires, wheels, and wheel bearings, 8-29  
Toe, 8-43  
Torsion bar, 8-12  
Torque converters, 4-27  
Track adjustment, 6-17  
Track and track frames, 6-13  
Track assembly, 6-13  
Track chain, 6-13  
Track frame, 6-15  
Track frame rollers, 6-15  
Track guiding guards, 6-16  
Track lubrication, 6-17  
Track shoe, 6-14  
Track-frame assemblies, maintenance of, 6-17  
Tracking, 8-45  
Tractor protection valve, 7-40  
Trailer control valve, 7-40  
Tram gauge, 8-47  
Transaxles, 4-41  
Transfer case maintenance and service, 5-31  
Transfer cases, 5-28

Transmission case, 4-13  
Transmission construction, 4-13  
Transmission of forces through liquid, 3-2  
Transmission overhaul, 4-23  
Transmission service, 3-25  
Transmission shafts, 4-13  
Transmission troubleshooting, 4-21  
Transmission types, 4-16  
Transistors, 1-6  
Treadle valve, 7-39  
Tripod joint, 5-7  
Troubleshooting steering systems, 8-28  
Truck frame, 8-3  
Tube repair, 8-37  
Tubes, 8-33  
Tubing, piping and hoses, 3-18  
Turn-signal systems, 2-49  
Turning corners, 5-13  
Turning radius gauges, 8-46  
Two-speed final drive, 5-14  
Two-stroke, 2-1  
Types of hydraulic fluids, 3-4  
Types of starting motors, 2-29

## U

Universal joint service, 5-8  
Universal joints, 5-2

## V

Vacuum advance, 2-37  
Vacuum boosters, 7-19  
Vacuum modulator valve, 4-36  
Vehicle stopping distance, 7-2  
Voltage, 1-9  
Volume and distance factors, 3-1

## W

Water-based fire-resistant fluids, 3-4  
Wheel alignment, 8-41  
Wheel alignment tools and equipment, 8-45  
Wheel balancing, 8-38  
Wheel bearing and hub assembly, 8-35  
Wheel bearing service, 8-39  
Wheels, 8-33  
Winches, 6-19  
Winches and wire rope, 6-19  
Windshield wipers, 2-58  
Wire rope attachments, 6-29  
Wire rope failure, 6-24  
Wire rope maintenance, 6-28  
Wire rope, 6-21  
Wire rope, characteristics of, 6-23  
Wire rope, composition of, 6-21  
Wire rope, grades of, 6-22  
Wire rope, handling and care of, 6-24  
Wire rope, lays of, 6-22  
Wire rope, measuring of, 6-24  
Wire rope, safe working load (SWL), 6-24  
Wire support and protection, 2-62  
Wire terminal ends, 2-61  
Wiring assemblies, 2-59  
Wiring diagrams, 2-61  
Wiring identification, 2-60  
Worm and nut, 8-19  
Worm and roller, 8-19  
Worm and sector, 8-18

## Z

Zener diodes, 1-6

---

---

# *Assignment Questions*

---

---

**Information:** The text pages that you are to study are provided at the beginning of the assignment questions.



## ASSIGNMENT 1

Textbook Assignment "Basic Automotive Electricity" and "Automotive Electrical Circuits and Wiring," chapters 1 and 2, pages 1-1 through 2-40.

---

- 1-1. All matter is made up of tiny particles. These particles are known by what term?
1. Protons
  2. Electrons
  3. Neutrons
  4. Atoms
- 1-2. A group of electrons produce what type of electrical charge?
1. Positive
  2. Negative
  3. Neutral
  4. Ionized
- 1-3. Electrical energy is transferred through conductors by what means?
1. The movement of free electrons
  2. The movement of free protons
  3. The movement of free neutrons
  4. The movement of free quarks
- 1-4. In a semiconductor, what type of material is doped to yield free electrons?
1. O-type
  2. P-type
  3. N-type
  4. Y-type
- 1-5. What type of electrical device is used in electrical circuits to control the flow of current and operates by either allowing or not allowing current to flow?
1. Transistor
  2. Diode
  3. Resistor
  4. Thermistor
- 1-6. What transistor design is the most often used in automotive applications?
1. PPN
  2. NNP
  3. PNP
  4. NPN
- 1-7. In an electrical circuit, current (or electron) flow is measured in amps and is known as
1. voltage
  2. amperage
  3. resistance
  4. ohms
- 1-8. Using Ohm's law, what is the amperage in a circuit if the voltage is 13.8 and resistance is 2.25 ohms?
1. 3.16
  2. 3.61
  3. 5.10
  4. 6.13

- 1-9. What type of automotive circuit allows the disconnection or burning out of any individual component without affecting the operation of the others?
1. Series-parallel
  2. Parallel-series
  3. Series
  4. Parallel
- 1-10. To have a series-parallel circuit, you must have what minimum number of resistance units?
1. One
  2. Two
  3. Three
  4. Four
- 1-11. What type of circuit failure occurs when the resistance in the wiring circuit is such that current can NOT flow between the battery and the unit it operates?
1. Short circuit
  2. Open circuit
  3. Ground circuit
  4. Dead circuit
- 1-12. When the direction of current flow is known, what rule can be used to determine the north pole of an electromagnet?
1. Right-hand
  2. Left-hand
  3. Lines-of-force
  4. Ohm's
- 1-13. How is electromagnetic induction produced in an ac generator?
1. The wire is moved through a stationary magnetic field
  2. The wire is stationary and the magnet is moved so the magnetic field is carried past the wire
  3. The wire and electromagnet are both held stationary and current is turned on and off
  4. Both the wire and electromagnet are moved, thereby alternating the magnetic field
- 1-14. What are the names of the five automotive electrical circuits?
1. Charging, starting, ignition, lighting, and accessory
  2. Starting, lighting, accessory, charging, and cranking
  3. Lighting, battery, power generation, accessory, and starting
  4. Ignition, power generation, charging, starting, and accessory
- 1-15. In a lead-acid battery, current is produced by what type of reaction?
1. Photochemical
  2. Chemical
  3. Photoelectric
  4. Electronic
- 1-16. A 12-volt lead-acid, automotive battery consists of how many elements that are connected in series?
1. Six
  2. Two
  3. Three
  4. Four



- 1-17. The positive plates in a charged lead-acid battery contain what chemical compound?
1. Lead phosphate
  2. Lead sulfate
  3. Lead chromate
  4. Lead peroxide
- 1-18. Why are the cell elements of a storage battery elevated inside the case?
1. To allow the electrolyte to circulate under the elements
  2. To prevent the elements from shorting against the case
  3. To reduce the amount of lead required for connecting the elements and terminal posts
  4. To prevent shorting of the elements when material from the plates settles to the bottom of the case
- 1-19. When the temperature is 80°F, a fully charged lead-acid battery will produce what specific gravity reading?
1. 1.28
  2. 1.82
  3. 2.18
  4. 2.81
- 1-20. When taking a hydrometer reading of a battery whose temperature is 100°F, you must make what modification to the reading to determine the actual specific gravity of the electrolyte?
1. Add 0.006
  2. Add 0.008
  3. Add 0.003
  4. Add 0.004
- 1-21. The capacity of a battery cell is NOT affected by which of the following factors?
1. The area of the plates in contact with the electrolyte and the quantity and specific gravity of the electrolyte
  2. The type of separators and the final limiting voltage
  3. The general condition of the battery (degree of sulfating, plates buckled, separators warped, sediment in the bottom of the cells, etc.)
  4. The number of elements connected in parallel
- 1-22. What are the two methods for rating lead-acid storage batteries?
1. Reserve capacity rating and discharge rating
  2. Reserve capacity rating and ampere-hour rating
  3. Cold-cranking rating and reserve capacity rating
  4. Cold-cranking rating and discharge rating
- 1-23. In battery charging, either the current or voltage is kept constant.
1. True
  2. False
- 1-24. When charging a 19-plate battery by the constant-current method, you should use what charging rate?
1. 9 amp
  2. 10 amp
  3. 19 amp
  4. 20 amp

- 1-25. Which of the following factors produces the value of the charging current in a constant voltage battery charger?
1. The battery increasingly resists current as its own charge builds
  2. A clock-actuated rheostat adjusts the current value
  3. A rectifier tube automatically adjusts the current value
  4. The operator changes plug-in positions to lower the charger output at half-hour intervals
- 1-26. You are about to connect a battery to a charger when you notice that the terminal markings on the battery post are not readable. To ensure correct battery-to-charger connections, you should take what action?
1. Check the battery with an ammeter to determine the positive post
  2. Connect the larger battery post to the unmarked charger terminal
  3. Energize the charger and observe the reading on the charger gauge as you touch the battery cables to the charger
  4. Connect the larger battery post to the marked charger terminal
- 1-27. When charging batteries, you should take which of the following actions?
1. Add electrolyte to any cell in which the fluid level is below the top of the plates before charging
  2. Remove the vent plugs to prevent an accumulation of gases
  3. Take frequent hydrometer readings to determine if the battery is functioning properly during charging
  4. Remove each battery for a 10-minute break when half charged
- 1-28. What should you do with a new 12-volt battery that registers only 9 volts on a voltmeter?
1. Add electrolyte
  2. Recharge it
  3. Discard it
  4. Place it in service to see whether its voltage will increase or decrease
- 1-29. What procedure is considered the only safe way to mix electrolyte for a lead-acid battery?
1. Pour water into acid slowly and stir gently
  2. Pour water into acid slowly and stir vigorously
  3. Pour acid into water slowly and stir gently
  4. Pour acid into water slowly and stir vigorously
- 1-30. When cleaning the top of a lead-acid battery, you should use a
1. soft bristle brush and a mixture of water and baking soda
  2. soft bristle brush and a mixture of water and muratic acid
  3. stiff bristle brush and a mixture of water and baking soda
  4. stiff bristle brush and a mixture of water and muratic acid
- 1-31. What test allows you to determine the general condition of a maintenance-free battery?
1. Cell voltage
  2. Battery leakage
  3. Battery drain
  4. Battery voltage

- 1-32. When load testing a battery with a cold-cranking rating of 350 amps, you should load the battery to what total number of amps?
1. 150
  2. 175
  3. 200
  4. 225
- 1-33. The generator converts mechanical energy into electrical energy and restores the battery with the energy it expends.
1. True
  2. False
- 1-34. The current generated by an alternator is converted to direct current by means of what component?
1. Armature coil
  2. Condenser
  3. Rectifier
  4. Station field coil
- 1-35. The alternating current in the armature coil of a dc generator is changed to direct current in the external circuit by what component?
1. Armature
  2. Commutator
  3. Changes in the polarity of the field
  4. Slip rings
- 1-36. The output of a dc generator is NOT determined by which of the following factors?
1. The speed of the armature rotation
  2. The number of armature conductors
  3. The strength of the magnetic field
  4. The weakness of the ions
- 1-37. The current regulator functions to protect the electrical system by
1. limiting battery output
  2. limiting generator output
  3. disconnecting the electrical system
  4. increasing resistance at the generator
- 1-38. What condition causes solder globules to form inside the cover band of a generator?
1. Excessive current output
  2. Open field circuit
  3. Excessively worn brushes
  4. Internally shorted armature
- 1-39. A test lamp lights with normal brilliance when it is connected to the field lead terminal of a generator. What condition does this indicate?
1. An open field
  2. A normal field
  3. A shorted field
  4. A grounded field
- 1-40. When a milliammeter reading near zero is obtained across a pair of commutator segments on an armature that is mounted in a growler, the coil is
1. open
  2. shorted
  3. normal
  4. grounded

- 1-41. What component of an alternator is mounted on the rotor shaft and provides current to the rotor windings?
1. Slip rings
  2. Claw poles
  3. Stator core
  4. Coils
- 1-42. In what manner are stator windings connected in an alternator?
1. One end is connected to the positive diodes and the other end to the negative diodes
  2. One end is connected to the stator assembly and the other end to the rectifier assembly
  3. One end is connected to the negative diodes and the other end to the field windings
  4. One end is connected to the electrical terminals and the other end to the rotor shaft
- 1-43. What type of stator will provide good current output at low engine speeds?
1. Delta-type
  2. Omega-type
  3. K-type
  4. Y-type
- 1-44. A total of how many diodes are grounded in an alternator?
1. One
  2. Two
  3. Three
  4. Four
- 1-45. Grounding the field terminal of the alternator will result in damage to the
1. regulator
  2. diodes
  3. rotor windings
  4. alternator
- 1-46. A charging system containing an alternator can be checked for proper operation by means of a/an
1. ammeter
  2. voltmeter
  3. screwdriver
  4. jumper wire
- 1-47. To determine if an alternator rotor is internally shorted, you can test the rotor windings with what device?
1. Armature growler
  2. Galvanometer
  3. Test lamp
  4. Ohmmeter
- 1-48. Testing of an alternator stator is limited to
1. shorts and opens
  2. opens and grounds
  3. grounds and continuity
  4. continuity and shorts
- 1-49. Which of the following charging system tests allow you to measure the charging system voltage under low output, low load conditions?
1. Regulator bypass
  2. Charging system output
  3. Regulator voltage
  4. Charging system bypass

- 1-50. When performing a regulator bypass test, you should use which of the following methods to bypass the voltage regulator?
1. Place a jumper wire from the field terminals of the alternator to the engine block
  2. Place a jumper wire from the test tab to the field terminals of the alternator
  3. Place a jumper wire across the battery and field terminals of the alternator
  4. Unplug the wire from the regulator
- 1-51. What mechanism relies on the principle of inertial force to make the drive pinion mesh with the flywheel?
1. The Bendix drive
  2. The overrunning clutch
  3. The Dyer drive
  4. The reduction drive
- 1-52. In a starting circuit containing a solenoid, when is battery current supplied to the starter motor?
1. When the remote control switch is closed
  2. At the time the ignition switch is turned to the start position
  3. After the starter pinion is engaged with the flywheel
  4. When the plunger closes the contacts in the solenoid
- 1-53. Continued starter operation after releasing the starter button or ignition key is often caused by
1. a broken Bendix spring
  2. a worn solenoid plunger
  3. shorted solenoid windings
  4. a faulty pinion and rotor assembly
- 1-54. Field windings vary according to application. What is the most popular configuration used to provide a large amount of low-speed torque?
1. Six windings, series-parallel
  2. Two windings, parallel
  3. Three windings, series-parallel
  4. Four windings, series
- 1-55. Which of the following starting circuit components is common to all vehicles and equipment having automatic transmissions?
1. Starter solenoid
  2. Relay
  3. Neutral safety switch
  4. Double reduction starter
- 1-56. When it is necessary to adjust a neutral safety switch, which of the following test equipment is required?
1. Voltmeter
  2. Ohmmeter
  3. Inductive ammeter
  4. Test light
- 1-57. When inspecting a disassembled starter, you should replace the brushes if they are less than
1. one half of their original size
  2. one third of their original size
  3. one fourth of their original size
  4. one eighth of their original size

- 1-58. To determine the operating condition of the starter circuit, you should use which of the following tests to measure the amount of amperage used by the circuit?
1. Starter circuit resistance
  2. Starter circuit voltage drop
  3. Stator current draw
  4. Starter ground
- 1-59. The battery-ignition circuit consists of a total of how many circuits?
1. One
  2. Two
  3. Three
  4. Four
- 1-60. Which component in the ignition circuit provides high voltage in the secondary circuit?
1. Ignition distributor
  2. Ballast resistor
  3. Battery
  4. Ignition coil
- 1-61. In an ignition circuit, high voltage is directed to the spark plugs in the correct firing order by what component?
1. Ballast resistor
  2. Ignition coil
  3. Distributor rotor
  4. Spark plug wires
- 1-62. Which of the following actions is NOT a function of the distributor in the ignition circuit?
1. Actuate the ON/OFF cycles of current flow through the primary windings of the coil
  2. Distribute the high voltage surges of the coil to the spark plugs
  3. Change spark timing with changes in engine load
  4. Deactivate the thermostat
- 1-63. A nonresistor type spark plug is designed to reduce static in the radio in a vehicle.
1. True
  2. False
- 1-64. When troubleshooting an ignition circuit, you should change the manufacturer's specified heat range of the spark plugs when what condition exists?
1. Increased resistance is required by the circuit
  2. Abnormal operating conditions are encountered
  3. Ignition timing is changed from the manufacturer's setting
  4. High voltage surges in the primary circuit are reduced
- 1-65. A function of the condenser in a contact-point ignition system is to
1. stop the flow of the magnetic lines of flux when the points open
  2. regulate the flow of current through the secondary winding
  3. allow for a rapid collapse of the magnetic field around the primary winding
  4. prevent arcing at the points when they are first opened

- 1-66. The distributor contact points and cam provide a means of opening and closing the primary circuit.
1. True
  2. False
- 1-67. The amount of time that the points remain closed between openings, given in degrees of distributor rotation, is known as
1. point timing
  2. point dwell
  3. point angle
  4. point arcing
- 1-68. What component opens and closes the primary circuit of an electronic ignition system?
1. Electronic module control (EMC)
  2. Electronic primary control (EPC)
  3. Electronic circuit control (ECC)
  4. Electronic control unit (ECU)
- 1-69. An electronic ignition system is equipped with a Hall effect sensor. In this system there are the same number of shutters as there are
1. transistors
  2. diodes
  3. engine cylinders
  4. cam lobes
- 1-70. What timing advance mechanism provides additional spark when the engine load is low and at part throttle?
1. Vacuum
  2. Centrifugal
  3. Transistorized
  4. Electronic
- 1-71. In a computerized timing advance mechanism, what sensor reports piston position to the computer?
1. Crankshaft
  2. Camshaft
  3. Throttle
  4. Height
- 1-72. A grayish tan deposit on the insulator of a spark plug indicates what condition exists?
1. Normal operation
  2. Carbon fouled
  3. Ash fouled
  4. Preignition damage
- 1-73. How often should spark plugs be regapped?
1. Each time the vehicle is serviced
  2. At 6,000 mile intervals
  3. Any time they are removed for inspection
  4. During a "B" PM only
- 1-74. Some manufacturers specify spark plug torque, while others recommend bottoming the plugs on the seat and then turning an additional one-quarter to one-third turn.
1. True
  2. False

1-75. You have performed a spark plug wire resistance test. The test should not show the resistance to be over 5,000 ohms per inch or what total number of ohms?

1. 25,000
2. 50,000
3. 100,000
4. 125,000



## ASSIGNMENT 2

Textbook Assignment: "Automotive Electrical Circuits and Wiring" (continued) and "Hydraulic and Pneumatic Systems," chapters 2 and 3, pages 2-40 through 3-37.

---

- 2-1. Of the following conditions on a distributor cap, which one will short coil voltage to ground?
1. Faulty distributor lead
  2. Broken coil wire
  3. Carbon trace
  4. Broken rotor
- 2-2. When the points in a contact-point distributor become burnt or pitted, you should take what action?
1. Clean the points with a special file
  2. Remove any burrs or pits with fine sandpaper
  3. Clean the points with a rubbing block and realign
  4. Discard them and install a new set
- 2-3. After installing contact points, you notice that the faces do not make full contact. What corrective action should you take?
1. File the faces straight across the edge that is riding high
  2. Bend the movable breaker arm
  3. Bend the stationary contact bracket
  4. Remove the points and realign the faces
- 2-4. When setting the dwell on a contact-point distributor, you should replace the distributor if the dwell varies more than what number of degree(s)?
1. 1
  2. 2
  3. 3
  4. 4
- 2-5. When testing an electronic distributor, you conduct what test to check the resistance of the pickup coil?
1. Pickup coil ammeter test
  2. Pickup coil ohmmeter test
  3. Pickup coil voltage drop test
  4. Pickup coil ECU test
- 2-6. What tool should you use to set the pickup coil air gap?
1. Multi-blade steel feeler gauge
  2. Nonmagnetic feeler gauge
  3. Dwell meter
  4. 12-volt test light

- 2-7. To advance timing, you should turn the distributor housing in the same direction as the shaft rotation.
1. True
  2. False
- 2-8. Which of the following conditions results from ignition timing being too advanced?
1. Spark knock
  2. Poor fuel economy
  3. Sluggish acceleration
  4. Overheated exhaust manifold
- 2-9. Navy automotive and construction equipment lighting systems operate on what voltages?
1. 6 or 12 volts
  2. 12 or 18 volts
  3. 12 or 24 volts
  4. 18 or 24 volts
- 2-10. Of the following terms, which one refers to the luminous intensity of an incandescent lamp?
1. Candlepower
  2. Rated size
  3. Brightness
  4. Filaments
- 2-11. A halogen light increases light output by what percentage?
1. 10
  2. 15
  3. 20
  4. 25
- 2-12. How far in front of the vehicle should you locate the aiming screen when aligning headlights?
1. 10 feet
  2. 15 feet
  3. 20 feet
  4. 25 feet
- 2-13. When the headlights of a vehicle are centered 28 inches from the ground, how high should the reference line on the aiming screen be above ground level?
1. 24 inches
  2. 26 inches
  3. 28 inches
  4. 30 inches
- 2-14. When headlights are correctly aimed, the high intensity light beams drop what distance for every 25 feet away from the bulb?
1. 5 inches
  2. 2 inches
  3. 3 inches
  4. 4 inches
- 2-15. The aiming of truck headlights differs from the aiming of automobile headlights to compensate for which of the following conditions?
1. The effect of the variations in loads
  2. The height of the vehicle
  3. The width of the vehicle
  4. The size of tires used

- 2-16. On tactical vehicles equipped with blackout lights, the driving light is designed to provide light directly in front of the vehicle out to a distance of what number of feet?
1. 10
  2. 15
  3. 20
  4. 25
- 2-17. The function of what component is to turn off the turn signal switch?
1. Composite cam
  2. Limiting cam
  3. Canceling cam
  4. Cutoff cam
- 2-18. A burned-out fuse has a discolored sight glass. This condition indicates the existence of what problem?
1. The rating of the fuse is too low
  2. An overloaded circuit
  3. An open circuit
  4. A short in the wiring
- 2-19. You are operating a vehicle with a 12-volt electrical system. The voltmeter in the vehicle should indicate a reading that falls within what voltage range?
1. 11.5 to 12.2
  2. 13.2 to 14.5
  3. 15.5 to 16.2
  4. 17.5 to 18.3
- 2-20. What component supplies power for the small electric motor that rotates the input shaft of an electric speedometer?
1. Magnet generator
  2. Thermistor generator
  3. Distribution generator
  4. Resolution generator
- 2-21. An electronic tachometer on a diesel engine derives its input signal from
1. a pulse signal from the distributor as it switches the coil on and off
  2. a signal from a magnetic pickup coil that has its field interrupted by a rotating pole piece
  3. alternating current generated by the stator terminal of the alternator
  4. a power signal that is generated through a magnetic pickup at the camshaft
- 2-22. What component in the windshield wiper switch provides the operator a means of delaying windshield wiper action?
1. Thermistor
  2. Variable speed resistor
  3. Rheostat
  4. Reculor

- 2-23. On which of the following types of equipment will you find numbered tags that identify the wiring circuits?
1. Sedans
  2. M-series vehicles
  3. Track-mounted equipment
  4. Wheel-mounted construction equipment
- 2-24. All construction equipment regardless of manufacturer use the same color code for each component.
1. True
  2. False
- 2-25. Wires passing through holes in a metal member of the body or frame should be protected by which of the following types of materials?
1. Plastic clamps
  2. Flexible tubing
  3. Rubber grommets
  4. Electrical tape
- 2-26. A properly constructed hydraulic system possesses which of the following characteristics?
1. The use of complicated gears, cams, and levers is required
  2. Provides variable motion only in a straight-line transmission of power
  3. Low temperature changes
  4. Motion can be transmitted without the slack inherent in the use of solid machine parts
- 2-27. When 50 pounds of force is applied to piston 1 (as shown in textbook figure 3-4), how many pounds of force is applied to piston 2?
1. 25
  2. 50
  3. 75
  4. 100
- 2-28. Referring to textbook figure 3-5, when piston 1 is 4 square inches and is pushed down 2 inches and piston 2 is 16 square inches, how far will piston 2 move?
1. 1/2 inch
  2. 1/8 inch
  3. 1/4 inch
  4. 1/16 inch
- 2-29. What are the three most common types of hydraulic fluids?
1. Petroleum-based, synthetic fire-resistant, petroleum-based fire-resistant
  2. Water-based, phosphate ester fire resistant, water-based fire-resistant
  3. Silicon-based, petroleum-based fire-resistant, water-based fire-resistant
  4. Petroleum-based, synthetic fire-resistant, water-based fire-resistant

- 2-30. A properly designed and constructed hydraulic reservoir should be capable of
1. separating air from the oil
  2. causing a vortex
  3. dissipating air bubbles
  4. maintaining line pressure
- 2-31. Why is the hydraulic reservoir vented?
1. To prevent the loss of fluid
  2. To allow the reservoir to breathe
  3. To separate air from the fluid
  4. To dissipate heat from the fluid
- 2-32. In a standard hydraulic system, the strainer is at what location?
1. On the discharge side of the pump
  2. Between the filter and the pump
  3. In the pressure relief line
  4. On the pump suction lines
- 2-33. The operating pressure within a hydraulic system is created by the
1. pumping capacity of the pump
  2. opening and closing of the relief valve
  3. resistance encountered by the fluid
  4. the displacement of the pump
- 2-34. The amount of fluid that a hydraulic pump can deliver per cycle is known by what term?
1. Pump displacement
  2. Discharge displacement
  3. Volumetric output
  4. Variable output
- 2-35. Which of the following types of hydraulic pumps is designed to operate at moderate speeds which reduces erosion and excessive wear of the pump?
1. Rotary
  2. Centrifugal
  3. Diaphragm
  4. Reciprocating
- 2-36. Which of the following actions is NOT a function performed by the valves in a hydraulic system?
1. Prevents leakage between precision machined surfaces
  2. Controls pressure in the system
  3. Directs the flow of fluid
  4. Regulates the flow of fluid
- 2-37. In a hydraulic system, what valve is designed to regulate the flow of the hydraulic fluid?
1. Directional control
  2. Functional control
  3. Flow control
  4. Pressure control
- 2-38. In a hydraulic system, the directional control valve serves which of the following functions?
1. Keeps the hydraulic pump operating at a constant speed
  2. Regulates the pressure sent to the cylinder during operation
  3. Sends fluid back to the reservoir when pressure becomes too great
  4. Regulates the speed and operation of hydraulic cylinders

- 2-39. Which of the following is NOT a type of valving element used in the construction of a directional control valve?
1. Rotary spool
  2. Sliding spool
  3. Vented
  4. Poppet
- 2-40. The double-acting cylinder shown in textbook figure 3-31 will have more force applied to the cylinder as it is retracted.
1. True
  2. False
- 2-41. Why are accumulators used in some hydraulic systems?
1. To increase fluid capacity
  2. To absorb and stabilize shock loads
  3. To stabilize the amount of fluid pumped
  4. To store fluid for emergency fluid loss
- 2-42. What are the three major types of hydraulic accumulators?
1. Weight-loaded, bladder, and spring-loaded
  2. Bladder, floating piston, and diaphragm
  3. Spring-loaded, diaphragm, and pneumatic
  4. Pneumatic, weight-loaded, and spring-loaded
- 2-43. A fixed displacement hydraulic motor provides which of the following conditions?
1. Constant torque and variable speed
  2. Variable torque and constant speed
  3. Variable torque and variable speed
  4. Constant torque and variable speed
- 2-44. What type of hydraulic motor is most often used in hydraulic systems?
1. Constant-displacement
  2. Variable-displacement
  3. Fixed-displacement
  4. Hydrostatic-displacement
- 2-45. In a hydraulic system, which of the following is NOT an advantage of tubing over pipe?
1. Handles large volumes of fluid under high pressure
  2. Requires fewer fittings and has a better appearance
  3. Easier to bend, cut, and fit
  4. Easier to maintain
- 2-46. When piping is used in a hydraulic system, the pipe should be made of which of the following materials?
1. Electric welded mild steel
  2. Galvanized mild steel
  3. Seamless rolled mild steel
  4. Seamless cold-drawn mild steel

- 2-47. The flexible hose you are using has a designation of – 4. What is the inside diameter of this hose?
1. 1/16 inch
  2. 1/8 inch
  3. 1/4 inch
  4. 1/2 inch
- 2-48. Why is the inner tube (layer) of a flexible hydraulic hose made of synthetic material?
1. To reduce resistance
  2. To prevent deterioration
  3. To protect the strength members
  4. To prevent the hose from twisting
- 2-49. When placing support clamps on a length of flexible hose, you place the clamps at intervals of what maximum distance?
1. 12 inches
  2. 18 inches
  3. 24 inches
  4. 30 inches
- 2-50. Which of the following conditions is a result of mismatched hoses and fittings?
1. Pressure drops
  2. Pressure increases
  3. Cooling factor increases
  4. Twisted hose
- 2-51. Which of the following is NOT a type of fluid power seal?
1. Quad rings
  2. T seals
  3. X rings
  4. O rings
- 2-52. When more than one U cup is installed, they are installed in what manner?
1. Back to back
  2. Head to head
  3. Toe to toe
  4. Face to face
- 2-53. A hydraulic system on a piece of CESE should be flushed according to the manufacturer's recommendation.
1. True
  2. False
- 2-54. The branch of science that pertains to gaseous pressure and flow is known by what term?
1. Hydraulics
  2. Hydropneumatics
  3. Pneumatics
  4. Pneumatology
- 2-55. What law states that a volume of a gas is proportional to its absolute temperature if pressure remains constant?
1. Charles's Law
  2. Boyle's Law
  3. Pascal's Law
  4. Murphy's Law

- 2-56. Which of the following is NOT a desired quality of a gas used in a pneumatic system?
1. Free from acids
  2. Chemically stable
  3. Nonpoisonous
  4. Excellent lubricating power
- 2-57. Compressed air systems are categorized by operating pressure. A medium-pressure air system is rated at what pressure?
1. 180 to 1,500 psi
  2. 151 to 1,000 psi
  3. 175 to 1,200 psi
  4. 200 to 2,000 psi
- 2-58. In the rotary compressor, the sliding vanes are held against the pump casing by
1. spring tension
  2. oil pressure
  3. air pressure
  4. centrifugal force
- 2-59. Before the compressed air leaves the service valves of a rotary air compressor, the oil in the air is removed by what component?
1. The in-line oiler
  2. The receiver separator
  3. The oil cup
  4. The oil separator
- 2-60. What type of air compressor is equipped with an intercooler?
1. Multistage reciprocating
  2. Multistage rotary
  3. Multistage screw
  4. Single-stage screw
- 2-61. Why are aftercoolers used on some reciprocating air compressors?
1. To remove moisture from the air
  2. To eliminate surges in air delivery
  3. To prevent overheating of pneumatic tools
  4. To reduce pressure in the distribution system
- 2-62. On a rotary air compressor, engine speed is regulated to correspond with which of the following factors?
1. Capacity of the compressor
  2. Volume of air to supply the demand
  3. Discharge pressure of the compressor
  4. Temperature of air leaving the compressor
- 2-63. When using compressed air to clean the primary element of an air cleaner, you should not allow the air pressure to exceed
1. 10 psi
  2. 20 psi
  3. 30 psi
  4. 40 psi



2-64. When should you replace the air cleaner elements of an air compressor?

1. Each time the compressor oil is changed
2. After every 500 hours of service
3. When inspections shows an accumulation of greasy dirt
4. When the red band is visible in the air cleaner service indicator

2-65. Under normal operating conditions, compressor oil should be changed after what number of operating hours?

1. 250
2. 300
3. 425
4. 500

## ASSIGNMENT 3

Textbook Assignment: "Automotive Clutches, Transmissions, and Transaxles," chapter 4, pages 4-1 through 4-44.

---

- 3-1. What device is designed to disconnect the engine from the power train?
1. Universal joint
  2. Transfer case
  3. Clutch
  4. Differential
- 3-2. What component provides the operator the means with which to operate the clutch assembly?
1. Throw-out bearing
  2. Clutch release mechanism
  3. Clutch fork
  4. Pressure plate
- 3-3. The clutch fork transfers motion from the release mechanism to what components?
1. The clutch linkage and release bearing
  2. The clutch slave cylinder and pressure plate
  3. The pressure plate and clutch disc
  4. The release bearing and pressure plate
- 3-4. The release bearing is held on the clutch fork by
1. setscrews
  2. spring clips
  3. hydraulic pressure
  4. grooves cut into the release bearing
- 3-5. What clutch component can either engage or disengage the clutch disc and flywheel?
1. Pressure plate
  2. Release bearing
  3. Clutch housing
  4. Clutch fork
- 3-6. What component of the clutch disc absorbs vibration and shock produced by clutch engagement?
1. Facing springs
  2. Cushioning springs
  3. Torsion springs
  4. Friction springs
- 3-7. The flat metal springs, located under the friction lining of the disc, allow for smooth engagement of the clutch. These springs are known by which of the following terms?
1. Damping
  2. Torsion
  3. Friction
  4. Cushioning
- 3-8. Which of the following clutch components prevents the transmission from wobbling up and down when the clutch is released?
1. Pilot bearing
  2. Release bearing
  3. Diaphragm pressure plate
  4. Clutch release mechanism

- 3-9. Which of the following safety devices prevents the engine from starting unless the clutch pedal is fully depressed?
1. Clutch start switch
  2. Transmission safety switch
  3. Engine failsafe switch
  4. Neutral safety switch
- 3-10. How is a hydraulically operated clutch adjusted?
1. By turning the eccentric cam in the clutch pedal support
  2. By shortening and lengthening the slave cylinder pushrod
  3. By lengthening the effective stroke of the piston of the master cylinder
  4. By bleeding off a small amount of fluid. at the slave cylinder
- 3-11. You are in the field and no manuals are available. What amount of clutch pedal free travel will allow for adequate clutch operation until the vehicle reaches the shop?
1. 1 inch
  2. 2 inches
  3. 1 1/2 inches
  4. 4 inches
- 3-12. What is the most common cause of premature clutch troubles?
1. Operator abuse
  2. Misaligned transmission
  3. Over lubrication
  4. Stop-and-go traffic
- 3-13. Which of the following conditions will result in the clutch slipping?
1. Loose spring shackles
  2. Bent crankshaft flange
  3. Loose transmission mount
  4. Broken motor mount
- 3-14. An operator reports that a vehicle has a severe vibration when accelerated from a standstill. What is the most likely cause of this trouble?
1. Excessive free play
  2. Broken disc facing
  3. Bent release levers
  4. Worn release bearing
- 3-15. An operator reports hearing rattling sounds when the clutch is engaged. This condition is generally due to which of the following problems?
1. Worn pilot bearing
  2. Worn clutch disc facing
  3. A broken clutch disc torsion spring
  4. A broken clutch release mechanism
- 3-16. A pilot bearing that is worn or lacks lubricant will produce noise in the clutch when which of the following conditions exists?
1. The transmission is in gear
  2. The clutch is disengaged
  3. The vehicle is standing still
  4. The clutch is engaged

3-17. An operator reports that a vehicle has "clutch-pedal pulsation." A mechanic should know that this means that

1. slippage between the clutch disc facing and the flywheel is being sensed through the clutch pedal
2. the clutch has a strong jerk that is being sensed through the clutch pedal
3. a series of slight movements can be felt on the clutch pedal when the clutch is being disengaged
4. there must be dirt or grease on the clutch facings

3-18. Clutch-pedal pulsation can NOT be caused by which of the following conditions?

1. Misalignment of the engine and transmission
2. The flywheel not being seated on the crankshaft flange
3. A warped pressure plate or clutch disc
4. Excessive clutch pedal free play

3-19. When disassembling a clutch, you should take what action before removing the pressure plate?

1. Relieve the tension on the pressure plate springs
2. Check the thickness of the clutch disc
3. Loosen the flywheel mounting bolts
4. Mark the pressure plate cover and flywheel

3-20. When overhauling a clutch, you should NOT inspect the pressure plate and flywheel for which of the following conditions?

1. Thickness
2. Cracks
3. Scoring
4. Warpage

3-21. Which of the following tool(s) are used to measure the amount of wear of a pilot bearing?

1. Inside caliper
2. Outside caliper
3. Telescoping gauge and micrometer
4. Thickness gauge and sliding scale

3-22. A clutch release bearing is running roughly. What action should the mechanic take?

1. Clean the bearing with solvent
2. Disassemble the bearing and smooth any rough areas
3. Repack the bearing with lubricant
4. Replace the bearing

3-23. What is the maximum number of adjustments on a pressure plate before installation?

1. One
2. Two
3. Three
4. Four

- 3-24. The pressure plate adjustment that positions the release levers and allows the release bearing to contact the levers simultaneously is known by which of the following terms?
1. Clearance height
  2. Relation height
  3. Finger height
  4. Free height
- 3-25. You are reassembling a clutch assembly and a clutch alignment tool is NOT available. You can center the clutch disc on the flywheel by using
1. an old clutch shaft from the same type of vehicle
  2. a wooden dowel the same size as the pilot bearing
  3. a pry bar to move the clutch disc up and down
  4. measured spacers to provide exact centering
- 3-26. What component provides a selection of gear ratios so a vehicle can operate under a variety of operating conditions and loads?
1. The transmission
  2. The differential
  3. The transfer case
  4. The final drive
- 3-27. In a manual transmission, what shaft is locked in place within the transmission case?
1. Input
  2. Reverse idler
  3. Countershaft
  4. Main
- 3-28. What are the four gear groups in a manual transmission?
1. Countershaft gears, input gear, output gear, and reverse idler gear
  2. Main shaft gears, output gear, synchronized gears, and reverse idler gear
  3. Input gear, countershaft gears, main shaft gears, and reverse idler gear
  4. Reverse gear, main shaft gears, countershaft gears, and output gear
- 3-29. Of the following functions, which one is a function of the synchronizer in a manual transmission?
1. Provides the operator an easy means of shifting gears
  2. Locks the main shaft gear to the main shaft
  3. Increases torque going to the drive wheels for quick acceleration
  4. Completes the power flow from the transmission to the drive wheels
- 3-30. What are the two types of shifting linkages used on manual transmissions?
1. External shift cable and internal shift rod
  2. Internal shift rod and external shift rail
  3. Internal shift cable and external rod
  4. External rod and internal shift rail

- 3-31. When the gears are shifted, what type of transmission locks the gears to their shafts using sliding collars?
1. Sliding gear
  2. Constant mesh
  3. Auxiliary
  4. Synchromesh
- 3-32. What is the function of the synchronizer in a synchromesh transmission?
1. To engage the main drive gear with the transmission main shaft
  2. To engage the first speed main shaft with the transmission main shaft
  3. To equalize the speed of the driving and driven members
  4. To engage the second speed main shaft with the transmission main shaft
- 3-33. The only function of the reverse gear in a synchromesh transmission is to
1. make the main shaft rotate in the opposite direction to the input shaft
  2. make the countershaft rotate in the opposite direction to the input shaft
  3. make the reverse idler shaft rotate in the opposite direction to the input shaft
  4. make the main shaft and reverse idler shaft rotate in the same direction to the input shaft
- 3-34. The reverse gear in a synchromesh transmission does NOT affect the gear ratio.
1. True
  2. False
- 3-35. What component of an auxiliary transmission is splined to the main shaft and slides backwards or forwards when shifting into high or low positions?
1. Synchronizer
  2. Gear type of dog clutch
  3. Over-center dog clutch
  4. High-lo shift fork
- 3-36. Which of the following conditions will result in a transmission being hard to shift?
1. Excessive countershaft end play
  2. Lack of spring tension on the shift lever detent
  3. Defective synchronizer
  4. Shift linkage out of adjustment
- 3-37. A clutch that is NOT releasing will cause a transmission to
1. make noise in neutral
  2. make noise in gear
  3. stick in gear
  4. slip out of gear
- 3-38. When disassembling a manual transmission, you find brass-colored particles. What components are most likely damaged?
1. The main drive gears
  2. The thrust washers
  3. The input shaft bearing
  4. The reverse idler shaft sleeve

- 3-39. When replacing a main shaft gear, you should also replace the matching gear on what shaft?
1. Countershaft
  2. Reverse idler
  3. Input
  4. Output
- 3-40. You have completed reassembling a transmission. Which of the following actions should you take before reinstalling the transmission?
1. Fill the case with proper lubricate
  2. Ensure the transmission shifts properly
  3. Measure end play clearance of the countershaft
  4. Lightly coat all components with a medium-grade lubricating oil
- 3-41. Operator control of an automatic transmission is limited to what action?
1. Changing the throttle position to match the load requirements of the vehicle
  2. Coupling and uncoupling the engine and automatic transmission through the torque converter
  3. Moving the control lever to select the gear range
  4. Locking the planetary gearsets to produce the required forward and reverse gear ratios
- 3-42. What action within an automatic transmission allows the transmission to shift gear ratios without operator control?
1. Locking and releasing of planetary gearsets in various combinations
  2. Locking and unlocking of hydraulic actuated multiple-disc clutches
  3. Controlling the hydraulic pressure that locks and releases brake bands
  4. Engaging and disengaging of the torque converter from the engine
- 3-43. In a torque converter, what component is known as the converter pump?
1. Stator
  2. Impeller
  3. Turbine
  4. Drive fan
- 3-44. The turbine of a torque converter is connected to what component?
1. Flywheel
  2. Crankshaft
  3. Transmission
  4. Clutch housing
- 3-45. The blades inside a torque converter are forced to rotate by
1. oil thrown by the pump
  2. centrifugal force generated by the clutch
  3. engine torque transmitted through the crankshaft
  4. pressure from the flywheel

- 3-46. In a torque converter, what action causes torque multiplication to occur?
1. The impeller is spinning faster than the turbine
  2. The impeller is spinning slower than the stator
  3. The turbine is spinning faster than the impeller
  4. The turbine is spinning slower than the stator
- 3-47. The condition that exists when the impeller of a torque converter is at maximum speed and the turbine is almost stationary is known by what term?
1. Torque speed
  2. Engine speed
  3. Acceleration speed
  4. Stall speed
- 3-48. What component locks the stator of a torque converter when the impeller is turning faster than the turbine?
1. Dog clutch
  2. One-way clutch
  3. Over-center clutch
  4. Multi-disc clutch
- 3-49. What type of torque converter eliminates the heat caused by torque converter slippage which results in increased fuel economy and transmission life?
1. Antislip
  2. Hydraulic
  3. Direct
  4. Lockup
- 3-50. What component of a lockup torque converter assists in dampening engine pulses entering the drive train?
1. Cushioning springs
  2. Facing springs
  3. Torsion springs
  4. Leaf springs
- 3-51. Of the following gears, which one is NOT a part of the makeup of the planetary gearset?
1. Sun
  2. Ring
  3. Planetary carrier
  4. Input
- 3-52. What gear is the center gear in a planetary gearset?
1. Planet pinion
  2. Ring
  3. Sun
  4. Planetary carrier
- 3-53. What component of an automatic transmission is used to transmit torque by locking elements of the planetary gearsets to rotating members within the transmission?
1. Over-center clutch
  2. Multiple-disc clutch
  3. One-way clutch
  4. Dog clutch



- 3-54. What component of a multiple-disc clutch is used to distribute application pressure equally on the surfaces of the clutch discs and plates?
1. Clutch hub
  2. Pressure plate
  3. Clutch drum
  4. Clutch springs
- 3-55. What component of a multiple-disc clutch ensures a rapid release of the clutch when hydraulic pressure to the clutch piston is released?
1. Clutch springs
  2. Clutch hub
  3. Clutch drum
  4. Pressure plate
- 3-56. What component of an automatic transmission is designed to lock a planetary gearset element to the transmission case so the element can act as a reactionary member?
1. Brake band
  2. Multiple-disc clutch
  3. Servo
  4. Valve body
- 3-57. Of the following functions, which one is NOT a basic function of the hydraulic system of an automatic transmission?
1. Actuate clutches and bands
  2. Control shifting patterns
  3. Circulate transmission fluid
  4. Control the planetary gearset elements
- 3-58. So it can be driven by the engine, the hydraulic pump of an automatic transmission is keyed to what component?
1. Transmission case
  2. Flywheel
  3. Torque converter hub
  4. Engine crankshaft
- 3-59. Of the following functions, which one is NOT a function of the hydraulic pump of an automatic transmission?
1. To produce pressure to operate the clutches
  2. To lubricate the moving parts of the transmission
  3. To keep the torque converter filled
  4. To route excess transmission fluid to the cooling tank
- 3-60. What valve in an automatic transmission is operated by the shift mechanism, allowing the operator to select park, neutral, reverse, or different drive ranges?
1. Manual
  2. Kickdown
  3. Governor
  4. Shift
- 3-61. What component works in conjunction with the vacuum modulator to determine shift points in an automatic transmission?
1. Manual valve
  2. Kickdown valve
  3. Governor valve
  4. Shift valve

- 3-62. What valve causes the transmission to shift into a lower gear during quick acceleration?
1. Kickdown
  2. Governor
  3. Shift
  4. Manual
- 3-63. In addition to giving off a burnt smell, overheated transmission fluid will turn what color?
1. Brown
  2. Black
  3. Red
  4. Blue
- 3-64. Using a transmission fluid that is incompatible with the unit you are working on may lead to which of the following problems?
1. The transmission overheating
  2. The transmission fluid foaming
  3. A milky appearance of the fluid
  4. An early transmission failure
- 3-65. Air trapped in the hydraulic system of an automatic transmission can cause which of the following problems?
1. High line pressure
  2. Slow application of the clutch plates
  3. Low torque output
  4. Hard shifting
- 3-66. Water mixed with automatic transmission fluid will turn the fluid what color?
1. Brown
  2. Milky
  3. Pink
  4. Tan
- 3-67. After a vehicle has been operated in severe service, the transmission will require a band adjustment.
1. True
  2. False
- 3-68. "Severe service" does NOT include which of the following conditions?
1. Construction operations
  2. Trailer towing
  3. Stop-and-go driving
  4. Contingency operations
- 3-69. Oil drained from an automatic transmission should be disposed of according to what instructions?
1. EPA
  2. Federal regulations
  3. Local civilian
  4. Local naval station
- 3-70. Which of the following factors is NOT an advantage of a vehicle with a transaxle and front-wheel drive?
1. Increased passenger compartment space
  2. Quieter operation
  3. Greater sprung weight
  4. Improved traction on slippery surfaces

3-71. In a manual transaxle the output shaft transfers torque to which of the following components?

1. Drive axles
2. Differential
3. Hub assembly
4. Gearbox

3-72. The flow of fluid to the pistons and servos of an automatic transaxle is controlled by what component?

1. Transaxle clutches and bands
2. Transaxle planetary gearsets
3. Transaxle differential
4. Transaxle valve body

## ASSIGNMENT 4

Textbook Assignment: "Drive Lines, Differentials, Drive Axles, and Power Train Accessories," chapter 5, pages 5-1 through 5-35.

---

- 4-1. Of the following functions, which one is NOT a function of a drive line assembly?
1. Provides a smooth power transfer
  2. Allows up-and-down movement of the rear axle
  3. Sends power from the transmission to the rear axle
  4. Maintains proper alignment of the rear axle and transmission
- 4-2. Which of the following drive line components is used only on long wheelbase vehicles?
1. Universal joint
  2. Center support bearing
  3. Drive shaft
  4. Slip yoke
- 4-3. What component of a drive line assembly transfers turning power from the front universal joint to the rear universal joint?
1. Slip yoke
  2. Rear yoke
  3. Drive shaft
  4. Flex shaft
- 4-4. What component of a drive shaft assembly provides free movement in a horizontal direction and is capable of transmitting torque?
1. Slip yoke
  2. Rear yoke
  3. Front universal joint
  4. Rear universal joint
- 4-5. What modification prevents drive shafts from vibrating at full-engine speed?
1. Magnafluxing the drive shaft
  2. Welding small weights to the light side of the shaft
  3. Placing weights on the opposite ends and opposite sides of the shaft
  4. Truing the shaft on a lathe
- 4-6. What type of drive shaft is enclosed and rotates within a support bearing to prevent whipping?
1. Hotchkiss
  2. Companion
  3. Flange tube
  4. Torque tube
- 4-7. What component of a drive train is used to allow changes in the angle of the drive line assembly?
1. Support bearing
  2. Companion flange
  3. Slip joint
  4. Universal joint

4-8. What type of drive shaft design prevents shaft speed fluctuations?

1. A drive shaft containing two universal joints assembled 90 degrees apart
2. A drive shaft containing one universal joint and one slip joint on the same end
3. A drive shaft containing one universal joint at the transmission and a slip joint at the differential
4. A drive shaft containing one universal joint at the differential and a slip joint at the transmission

4-9. What type of universal joint is most often used?

1. Double cardan
2. Ball and trunnion
3. Cross and roller
4. Bendix-Weiss

4-10. What type of universal joint has two cross-and-roller joints in tandem to form a single joint?

1. Ball-and-trunnion
2. Double-cardan
3. Rzeppa
4. Tripod

4-11. In a front-wheel drive vehicle, the outboard CV joint is a sliding joint that transfers rotating power from the axle shaft to the hub assembly.

1. True
2. False

4-12. The balls of a Rzeppa type constant-velocity joint

1. transfers rotating power from the axle shaft to the hub assembly
2. maintains an equally divided drive angle between the connected shafts
3. furnishes the only points of driving contact between the two halves of the coupling
4. ensures angular displacement of the shafts are maintained by the outward movement of the balls

4-13. When the driven shaft of a Rzeppa CV joint is moved 30 degrees, the cage and balls move what number of degrees?

1. 10
2. 15
3. 20
4. 30

4-14. What component of a tripod CV joint is splined to the axle shaft?

1. Inner spider
2. Outer yoke
3. Outer housing
4. Axle hub

4-15. Of the following functions, which one is NOT a function of a pillow block bearing in an auxiliary power train?

1. To support the drive shaft
2. To maintain drive shaft alignment
3. To prevent whipping under heavy loads
4. To prevent shimmy and poor control

- 4-16. An operator reports hearing a grinding noise coming from the drive shaft. This report most likely indicates the existence of what problem?
1. A worn center support bearing
  2. Worn splines in the slip yoke
  3. A worn universal joint
  4. A worn transmission housing bushing
- 4-17. Which of the following conditions indicates that a center support bearing is faulty?
1. A whining noise in the drive line
  2. Failure of the vehicle to start moving smoothly
  3. Frequent stalling when the clutch is engaged
  4. Vibration from the chassis at low speeds
- 4-18. When performing a drive shaft inspection, you take what action to check the U-joints?
1. Move them by prying with a pry bar
  2. Completely disassemble the joints
  3. Measure the play between the cross and roller
  4. Wiggle and rotate each joint back and forth
- 4-19. In what gear is a worn universal joint most often noticed?
1. First
  2. Second
  3. Fourth
  4. Reverse
- 4-20. Lubricating universal joints with a low-pressure grease gun prevents which of the following types of damage?
1. Bearing damage
  2. Seal damage
  3. Bearing seizure
  4. Over lubrication
- 4-21. You are removing the drive shaft from a vehicle. What component can be damaged if you allow the full weight of the drive shaft to hang from the slip yoke?
1. Rear U-joint
  2. Front bushing
  3. Extension housing
  4. Support bearing
- 4-22. When reassembling a universal joint, you should use what type of lubricant to prevent the bearings from falling out of the bearing cap?
1. High-temperature grease
  2. Wheel bearing grease
  3. Water pump lubricant
  4. Vaseline
- 4-23. What is the first indication that a vehicle has a faulty center support bearing?
1. A clunking sound when changing from acceleration to deceleration
  2. A whining sound coming from the drive shaft
  3. Excessive chassis vibration at low speed
  4. The drive shaft begins to wobble causing abnormal universal joint wear

- 4-24. When replacing the center support bearing, you should ensure that the
1. bearing shield contains grease
  2. grease fitting is in place
  3. dust shield is placed in its grooves correctly
  4. drive shaft alignment is maintained
- 4-25. Of the following functions, which one is a function of the differential in an automotive vehicle?
1. Connects the rear axles shafts
  2. Allows the axles to turn at different speeds when cornering
  3. Permits the driving axles to be driven as a single unit
  4. Transmits power indirectly to the drive axles
- 4-26. What type of differential carrier is constructed as part of the axle housing?
1. Removable
  2. Pinion
  3. Integral
  4. Axial
- 4-27. What component of a differential assembly holds the ring gear, the spider gears, and the inner ends of the axles?
1. Differential case
  2. Differential carrier
  3. Differential final drive
  4. Differential windlass
- 4-28. The outer end of the pinion gear is joined to the rear U-joint companion flange by
1. bolts
  2. lock rings
  3. splines
  4. snap rings
- 4-29. What component of a differential drives the ring gear?
1. Side gear
  2. Spider gear
  3. Spiral bevel gear
  4. Pinion gear
- 4-30. When repairing a differential, you must replace the ring and pinion as a matched set.
1. True
  2. False
- 4-31. What component of a differential is splined to the inner ends of the axles?
1. Differential integral gears
  2. Differential idler gears
  3. Differential pinion gears
  4. Differential side gears
- 4-32. Which of the following gear ratios of a final drive provides a substantial increase in acceleration; however, fuel economy is decreased?
1. 2.78
  2. 3.50
  3. 3.71
  4. 4.11

- 4-33. Which, if any, of the following components is part of a final drive?
1. Bevel drive pinion
  2. Differential carrier
  3. Saddle yoke
  4. None of the above
- 4-34. What type of final drive designs are most often used?
1. Double reduction and two-speed
  2. Spiral bevel gear and hypoid gear
  3. Limited slip and cone clutch
  4. Full-floating and three-quarter floating
- 4-35. What type of final drive has the pinion gear meshing with the ring gear below the center line and at a slight angle?
1. Hypoid
  2. Spiral bevel
  3. Double reduction
  4. Limited slip
- 4-36. A 5-ton military vehicle is equipped with what type of final drive?
1. Single-reduction
  2. Double-reduction
  3. Two-speed
  4. Limited slip
- 4-37. A two-speed final drive is limited to use in those vehicles containing one driving axle.
1. True
  2. False
- 4-38. In a two-speed final drive, what component is placed between the differential drive ring gear and the differential case?
1. Clutch pack
  2. Cone clutch
  3. Planetary gear train
  4. Sliding pinion gear
- 4-39. In a clutch pack type limited-slip differential, clutch packs are applied by the
1. centrifugal force of the spider gears and spring pressure
  2. friction of the steel disc and spring pressure
  3. spring force and the thrust action of the spider gears
  4. side pinion gears walking inside the side gears
- 4-40. Under rapid acceleration, the differential pinion gears of a cone clutch limited-slip differential push outward on what components?
1. Side gears
  2. Cone gears
  3. Flange casings
  4. Drive axles



- 4-41. What condition is generally accepted as the first hint of differential troubles?
1. Loss of traction
  2. Vehicle vibration
  3. Loss of lubricant
  4. Unusual noises
- 4-42. Which of the following differential troubles will produce a humming noise?
1. Lack of lubrication
  2. Improperly adjusted ring and pinion gears
  3. Improperly adjusted pinion and side gears
  4. Backlash is too great
- 4-43. Which of the following conditions generate a clunking sound in the differential?
1. Faulty differential gears
  2. Worn axle support bearings
  3. Excessive backlash between the ring-and-pinion gears
  4. Loose carrier bearings
- 4-44. When removing an integral differential, you should inspect and mark the individual components as they are removed.
1. True
  2. False
- 4-45. When replacing the seals in a differential, you should use which of the following tools?
1. Seal driver
  2. Hammer and a block of wood
  3. Slide hammer
  4. Seal insert
- 4-46. Which of the following methods are used to adjust pinion gear depth?
1. Using a collapsible spacer
  2. Tightening the pinion nut
  3. Replacing the shim pack
  4. Varying shim thickness
- 4-47. When adjusting the pinion bearing preload with a collapsible spacer, you should use which of the following tools to measure the pinion preload?
1. Dial indicator
  2. Foot-pound torque wrench
  3. Inch-pound torque wrench
  4. Feeler gauge
- 4-48. Which of the following problems results from having a differential case bearing preload that is too high?
1. Ring-and-pinion noise
  2. Overheated bearings
  3. Too much backlash
  4. Excessive differential case runout

- 4-49. Ring-and-pinion backlash is required for which of the following reasons?
1. To allow for heat expansion
  2. To prevent ring gear runout
  3. To ensure a good contact pattern
  4. To ensure that the pinion gear is perpendicular to the ring gear
- 4-50. When checking ring-and-pinion tooth contact pattern, you note that the pattern is located on the upper edge (high contact) of the teeth. What corrective action is required?
1. Move the ring gear away from the pinion
  2. Move the ring gear towards the pinion
  3. Move the pinion towards the ring gear
  4. Move the pinion away from the ring gear
- 4-51. The ideal tooth contact pattern on a used gear will have considerably more contact in which area of the gear?
1. The toe
  2. The heel
  3. The drive side
  4. The coast side
- 4-52. A live axle only serves as a support for part of the vehicle while providing a mounting for the wheel assembly.
1. True
  2. False
- 4-53. What type of axle housing is most often used?
1. One-piece
  2. Two-piece
  3. Guitar
  4. Banjo
- 4-54. Why are automotive axle housings vented?
1. To cool the lubricant
  2. To prevent pressure buildup
  3. To prevent overfilling
  4. To adjust for loads
- 4-55. The vehicle weight-supporting bearings in a full-floating axle are located
1. at the inner end of the axle housing
  2. on the outer end of the axle shaft
  3. on the outer end of the axle housing
  4. at the inner end of the axle shaft
- 4-56. What type of drive axle allows the axle shaft to be removed without removing the wheel?
1. Full-floating
  2. Semi-floating
  3. Three-quarter floating
  4. Half-floating

- 4-57. To permit the drive shaft of a front drive axle to pass beside the engine oil is accomplished by
1. using a constant velocity joint
  2. using an intermediate drive shaft
  3. using a transfer case
  4. having an off-center differential housing
- 4-58. In the front drive axle of a four-wheel drive vehicle, what component transfers power from the drive axles to the drive wheels?
1. Locking hubs
  2. Interconnecting shaft
  3. Outer stub shaft
  4. Sliding hub
- 4-59. In a front-wheel drive vehicle, what component of the front-wheel drive axle is splined to the side gears in the differential?
1. Interconnecting shaft
  2. Outer stub shaft
  3. Inner stub shaft
  4. Rzeppa joint
- 4-60. What action allows for a change in distance between the transaxle and the wheel hub?
1. The plunging action of the outer CV joint
  2. The plunging action of the inner CV joint
  3. The sliding action of the short shaft spline to the side gears
  4. The sliding action of the interconnecting shaft
- 4-61. Worn or damaged axle bearings produce what type of sound?
1. Clunking
  2. Grinding
  3. Humming
  4. Growling
- 4-62. To help ensure axle bearing problems do NOT reoccur, you should take what action?
1. Determine the cause of the part failure
  2. Perform all repairs according to the manufacturer's manual
  3. Follow the shop supervisor's instructions
  4. Install a higher quality part
- 4-63. When removing a pressed-on bearing collar from an axle, you should use which of the following tools?
1. Cutting torch
  2. Hand grinder
  3. Slide hammer
  4. Bearing puller
- 4-64. When removing an axle bearing using a hydraulic press, you should place the driving tool so it contacts what area of the bearing?
1. The outer race
  2. The inner race
  3. The bearing collar
  4. The bearing sleeve

- 4-65. What is the proper tool for removing a housing-mounted axle seal?
1. Hand grinder
  2. Pry bar
  3. Cutting torch
  4. Slide hammer
- 4-66. What component is used to divide engine torque between the front and rear driving axles?
1. Power takeoff
  2. Auxiliary transmission
  3. Transfer case
  4. Power divider
- 4-67. Shifting is accomplished in a conventional transfer case by what component?
1. Sliding cone clutch
  2. External shifting rail
  3. Synchronizers
  4. Sliding dog clutch
- 4-68. In a vehicle using a positive traction transfer case, what component is engaged when the rear wheels lose traction and provides power to the front wheels?
1. Sliding cone clutch
  2. Synchronizer
  3. Sprag unit
  4. Energizing springs
- 4-69. An operator reports that the transfer case is hard to shift. Which of the following problems is NOT a possible cause?
1. Excessive end play
  2. Clutch slippage
  3. Bent linkage
  4. Improperly linkage lubrication
- 4-70. A power takeoff unit is driven by what shaft of the transmission?
1. Main shaft
  2. Countershaft
  3. Idler shaft
  4. Accessory drive shaft
- 4-71. Faulty operation of a power takeoff unit is caused by which of the following problems?
1. Damaged linkage
  2. Improper spacing between the meshing gears
  3. Excessive end play
  4. Worn bearings
- 4-72. To compensate for PTO wear, you must take what action?
1. Add shims
  2. Remove shims
  3. Adjust the linkage
  4. Adjust the control lever

## ASSIGNMENT 5

Textbook Assignment: "Construction Equipment Power Trains," chapter 6, pages 6-1 through 6-32.

---

- 5-1. What are the two most common types of drive trains used in modern construction equipment?
1. Mechanical and hydromechanical
  2. Pneumatic and mechanical
  3. Hydrostatic and mechanical
  4. Pneumatic and hydrostatic
- 5-2. The power shift transmission is coupled to the torque converter through
1. interconnecting splines
  2. a swash plate
  3. a universal joint
  4. a jack shaft
- 5-3. What power shift transmission shaft has the reverse drive gear keyed to the front of the shaft?
1. Reverse clutch
  2. Forward clutch
  3. Spline
  4. Bevel pinion
- 5-4. When the high-lo lever of a power shift transmission is shifted, a sliding gear on the spline shaft meshes with gears on what shaft?
1. Reverse clutch
  2. Forward clutch
  3. Spline
  4. Bevel pinion
- 5-5. The pinion gear that is splined to the bevel pinion shaft is adjusted for pinion depth by adding shims.
1. True
  2. False
- 5-6. What two pistons are the heart of the forward and reverse hydraulic clutch in a power shift transmission?
1. Center and knock-off
  2. Accelerator and force
  3. Sintered and backing
  4. Separator and drum
- 5-7. Upon application of the hydraulic clutch, main oil pressure is directed through which of the following components?
1. Clutch shaft
  2. Force piston cavity
  3. Accelerator piston cavity
  4. Drive gear and drum
- 5-8. Before shifting the hi-lo-shifting lever in the power shift transmission, you must put the gearshift lever in neutral while the engine is running.
1. True
  2. False
- 5-9. What component is the center gear in a planetary gearset?
1. Planet pinion
  2. Ring gear
  3. Sun gear
  4. Planetary carrier

- 5-10. How many different ways can the planetary gearset be engaged to either increase or decrease torque?
1. Six
  2. Two
  3. Eight
  4. Four
- 5-11. In a planetary gearset, direct drive is achieved by locking
1. the planetary carrier
  2. the planet pinion
  3. the ring gear
  4. any two members together
- 5-12. In a planetary steering system, the sun gear, machined to the steering brake hub, performs the same function as what component in a conventional planetary system?
1. Pinion gear
  2. Planetary gear
  3. Carrier gear
  4. Ring gear
- 5-13. In a planetary steering system, braking prevents what action?
1. The sprocket drive shaft and steering brake hub from rotating
  2. The steering brake hub and sun gear from rotating
  3. Transmitting power from the sun gear to the sprocket drive shaft
  4. The pinion gears from walking around the sun gear on the steering brake hub
- 5-14. Adjusting the steering brakes of a planetary steering system is required because it provides what advantage?
1. Even braking
  2. Prevents slippage
  3. Even lining wear
  4. Prevents brake pull
- 5-15. The actuating disc assembly of the pivot brakes on tracked equipment is made up of what components?
1. Three discs that have laminated linings
  2. Two smooth discs held in position by studs
  3. Two steel plates splined to the sprocket drive
  4. Two steel plates with steel balls between them
- 5-16. In a hydrostatic drive train, mechanical power from the engine is converted to hydraulic power by what components?
1. Piston and cylinder
  2. Swash plate and displacement control valve
  3. Pump and motor
  4. Charge pump and cylinder block

- 5-17. A hydrostatic drive is designed to accomplish the functions of both a clutch and a transmission.
1. True
  2. False
- 5-18. What component of a hydrostatic drive train can have its angle varied so the volume and pressure of oil pumped by the pistons can be changed or the direction of the oil reversed?
1. Displacement control valve
  2. Low charge pressure control valve
  3. Shuttle valve
  4. Swash plate
- 5-19. In a hydrostatic drive train, what pump-motor combination will provide variable speed and constant torque?
1. A fixed displacement pump and fixed displacement motor
  2. A variable displacement pump and fixed displacement motor
  3. A fixed displacement pump and variable displacement motor
  4. A variable displacement pump and variable displacement motor
- 5-20. In a hydrostatic drive train, what pump-motor combination is the most flexible, but is also the most difficult to control?
1. A fixed displacement pump and fixed displacement motor
  2. A variable displacement pump and fixed displacement motor
  3. A fixed displacement pump and variable displacement motor
  4. A variable displacement pump and variable displacement motor
- 5-21. Which of the following factors has no bearing on the control of the operations of a hydrostatic drive?
1. Rate of oil flow
  2. Direction of oil flow
  3. Pressure of the oil
  4. Quality of the oil
- 5-22. Of the following advantages, which one is NOT provided by a hydrostatic drive?
1. Low torque available for starting up
  2. Smooth shifting
  3. Low maintenance and service
  4. Shifts "on-the go"
- 5-23. In a hydrostatic drive, what design feature determines the volume of oil displaced per revolution of the pump?
1. Speed of the engine
  2. Angle of the swash plate
  3. Alignment of the pump pistons and the outlet port
  4. Action of the high charge pressure control valve
- 5-24. What valve, located in the motor manifold, monitors the pressure of the forward flow of oil and protects the system from exceeding the rated psi?
1. Inlet check
  2. High-pressure relief
  3. Shuttle
  4. Low charge pressure control

- 5-25. In a hydrostatic drive system the pump drive shaft and cylinder block always rotates clockwise; however, the motor drive shaft and cylinder block may rotate either clockwise or counterclockwise.
1. True
  2. False
- 5-26. What are the two major components of the undercarriage on crawler-mounted equipment?
1. Track assembly and front idler
  2. Track frame and drive sprocket
  3. Front idler and drive sprocket
  4. Track frame and track assembly
- 5-27. The length of a track will gradually increase during normal use as a result of wear on the
1. track assembly and track frame
  2. track links
  3. sprocket and idler
  4. pins and bushings
- 5-28. Which of the following measurements are used to determine the wear of a track assembly?
1. Bushing diameter and track pitch
  2. Pin diameter and track pitch
  3. Link width and bushing diameter
  4. Chain length and link width
- 5-29. How many track links should you measure across when checking track pitch?
1. Five
  2. Two
  3. Three
  4. Four
- 5-30. What track frame components maintains alignment of the track assembly as it passes over the track frame?
1. Track rollers
  2. Guiding guards
  3. Front idler
  4. Carrier rollers
- 5-31. The operation of the recoil springs depends upon what factor?
1. Amount of tension on the idler
  2. Amount of tension on the sprocket
  3. Amount of tension on the track
  4. Amount of tension on the track frame
- 5-32. To relieve tension on the track of a modern crawler tractor, you should take what action?
1. Back off the adjusting nut on the idler yoke
  2. Add shims in front of the recoil spring
  3. Loosen the vent screw on the track adjuster
  4. Loosen and slide the carrier rollers forward
- 5-33. What track guiding guards reduce the wear on the roller flanges and track links?
1. Front
  2. Rear
  3. Center
  4. Bottom



- 5-34. Friction in a tight track robs the crawler tractor of needed horsepower.
1. True
  2. False
- 5-35. When the track on a crawler tractor is too loose, it will have a tendency to
1. cause the idler to wear rapidly
  2. come off when the tractor is turned
  3. damage track rollers
  4. increase pin and bushing wear
- 5-36. When it becomes necessary to adjust the track in the field, you should remove all the slack in the track and release the pressure until the front idler moves back a 1/2 inch.
1. True
  2. False
- 5-37. When inspecting a piece of tracked equipment, you notice that the track is out of alignment. What person determines what action should be taken?
1. Inspector
  2. Crew leader
  3. Operator of the track
  4. Shop supervisor
- 5-38. When removing a track, you can easily identify the master pin because it
1. is larger than the other pins
  2. has a locking device or a hole drilled in its end
  3. has a capital "M" cast into the end
  4. has three stripes engraved on it
- 5-39. Before replacing any components of the track or track frame, you should consult what publication?
1. NAVFAC P-300
  2. NAVFAC P-306
  3. NAVFAC P-458
  4. The manufacturer's service manual
- 5-40. In the NCF, what publication contains the guidelines for the maintenance and use of wire rope?
1. COMSECOND/COMTHIRD INST 11200.1
  2. NAVFAC P-404
  3. NAVFAC P-458
  4. NAVFAC P-306
- 5-41. The typical front-mounted winch is classified as what type of winch?
1. Sliding-clutch worm gear
  2. Sliding-collar worm gear
  3. Jaw-clutch worm gear
  4. Sliding-jaw worm gear
- 5-42. What component protects a winch from being overloaded?
1. Clutch key
  2. Worm-gear key
  3. Shear pin
  4. Handle pin
- 5-43. What brake prevents the drum from overrunning the cable when the cable is being unreeled?
1. Worm
  2. Shifter-bracket
  3. Winch support
  4. Shift lever

- 5-44. Failure of the winch to operate is usually the result of what component being broken or damaged?
1. Drive shaft
  2. Shear pin
  3. Universal joint
  4. PTO gear
- 5-45. A wire rope that has strands or wires that are shaped to conform to the curvature of the finished rope is known as
1. non-preformed wire rope
  2. non-conformed wire rope
  3. preformed wire rope
  4. conformed wire rope
- 5-46. Which of the following components is NOT part of the construction of a wire rope?
1. Wires
  2. Strands
  3. Core
  4. Filler
- 5-47. Wire rope is designated by the number of strands per rope and what other factor?
1. Length of the strand
  2. Diameter of the strand
  3. Number of wires per strand
  4. Number of strands per wire
- 5-48. What type of strand construction has alternating large and small wires that provide a combination of great flexibility with a strong resistance to abrasion?
1. Ordinary
  2. Seale
  3. Warrington
  4. Filler
- 5-49. What type of wire rope core is a separate wire rope over which the main strands of the rope are laid?
1. Fiber
  2. Wire strand
  3. Unconstrained
  4. Independent
- 5-50. Each square inch of improved plow steel wire rope can withstand a strain that is within what range, in pounds of pressure?
1. Between 100,000 to 120,000
  2. Between 240,000 to 260,000
  3. Between 300,000 to 320,000
  4. Between 440,000 to 460,000
- 5-51. What type of wire rope lays has the wires in the strands laid to the right, while the strands are laid to the left to form the wire rope?
1. Left lang lay
  2. Right regular lay
  3. Right lang lay
  4. Left regular lay

- 5-52. Because it is very flexible, what type of wire rope is acceptable for use on cranes?
1. 6 x 37
  2. 6 x 24
  3. 6 x 19
  4. 6 x 12
- 5-53. What wire rope characteristic includes a reserve of strength as a safety factor?
1. Crushing strength
  2. Fatigue resistance
  3. Tensile strength
  4. Wear resistance
- 5-54. When measuring the diameter of wire rope, you should measure what number of places at what minimum distance apart?
1. 5 places at least 4 feet apart
  2. 2 places at least 10 feet apart
  3. 3 places at least 5 feet apart
  4. 4 places at least 2 feet apart
- 5-55. Which of the following mistakes is NOT a common cause of wire rope failure?
1. Dragging over obstacles
  2. Improper coiling
  3. Cross winding on drums
  4. Using an excessive fleet angle
- 5-56. What type of wire rope damage starts with the formation of a loop?
1. Crush spots
  2. Wear spots
  3. Kinks
  4. Broken wires
- 5-57. Too large of a fleet angle can cause a wire rope to climb the flange of a sheave.
1. True
  2. False
- 5-58. In wire rope rigging, the diameter of the sheave should never be less than how many times the diameter of the wire rope?
1. 10
  2. 20
  3. 30
  4. 40
- 5-59. What total number of seizings is required for seizing a 7/8-inch wire rope?
1. One
  2. Two
  3. Three
  4. Four
- 5-60. Which of the following conditions will shorten the service life of wire rope?
1. Excessive fleet angle
  2. Lack of lubrication
  3. Improper lay
  4. Reverse bends

- 5-61. When you are working in the field, what wire rope lubricant ratio is recommended?
1. 70-percent diesel fuel to 30-percent new motor oil
  2. 70-percent used motor oil to 30-percent diesel fuel
  3. 70-percent gasoline to 30-percent used motor oil
  4. 70-percent new motor oil to 30-percent diesel fuel
- 5-62. Speltering is the technique of attaching a socket to a wire rope by pouring hot zinc around it.
1. True
  2. False
- 5-63. What type of wire rope attachment is used to make eyes in wire rope?
1. Wedge socket
  2. Wire rope clips
  3. Mousing
  4. Speltered socket
- 5-64. To form an eye with a 3/4-inch wire rope requires what total number of wire rope clips?
1. One
  2. Two
  3. Three
  4. Four
- 5-65. Wire rope eyes with thimbles and wire rope clips can hold approximately what percentage of the strength of a wire rope?
1. 60
  2. 70
  3. 80
  4. 90
- 5-66. At a swaged connection, what is the maximum amount of broken wires allowed before the fitting should be replaced?
1. One
  2. Two
  3. Three
  4. Four
- 5-67. When a swaged connection is made properly, it will provide what percentage of the capacity of the wire rope?
1. 75
  2. 80
  3. 90
  4. 100

5-68. A bent hook should be straightened by heating it with a torch.

1. True
2. False

5-69. Hooks should always be inspected before lifting a full-rated load.

1. True
2. False

5-70. What are the two types of shackles used in rigging?

1. Screw pin and round pin
2. Mousing and bow
3. Anchor and chain
4. Ring and thimble

## ASSIGNMENT 6

Textbook Assignment: "Brakes," chapter 7, pages 7-1 through 7-40.

---

- 6-1. What term is used to describe the energy an object possesses due to its relative motion?
1. Potential energy
  2. Kinetic energy
  3. Static energy
  4. Perpetual motion
- 6-2. When the speed of a vehicle is doubled, the amount of kinetic energy that must be overcome by braking action is multiplied by
1. 10 times
  2. 2 times
  3. 3 times
  4. 4 times
- 6-3. The time frame between the instant the operator decides that the brakes should be applied and the moment the brake system is activated is known by what term?
1. Total reaction time
  2. Decision reaction time
  3. Operator reaction time
  4. Stopping reaction time
- 6-4. The distance during the operator's reaction time and the distance during which the brakes are applied before the vehicle stops is known by what term?
1. Vehicle travel distance
  2. Total stopping distance
  3. Overall reaction distance
  4. Braking travel distance
- 6-5. In answering this question, refer to figure 7-3 in the text. You are driving an average vehicle with brakes that are in good condition. What is the vehicle braking distance for the vehicle when you are traveling at 60 miles per hour?
1. 186 feet
  2. 171 feet
  3. 163 feet
  4. 159 feet
- 6-6. Which of the following factors will NOT increase braking temperatures?
1. Extreme weather conditions
  2. Operator abuse
  3. Load on the vehicle
  4. Speed of the vehicle
- 6-7. On a typical rear-wheel drive vehicle the front brakes will handle what percentage of the braking power?
1. 60 to 70
  2. 70 to 80
  3. 30 to 40
  4. 40 to 50
- 6-8. Of the following functions, which one is NOT a function of the master cylinder in a hydraulic brake system?
1. Develops pressure
  2. Assists in equalizing the pressure required for braking
  3. Keeps the system full of fluid
  4. Prevents fluid from seeping past the cups of the wheel cylinders

- 6-9. Which of the following factors is an advantage of having a dual master cylinder in a hydraulic brake system?
1. It enables the brakes to be applied with less effort
  2. There is less chance of the brakes malfunctioning
  3. It causes the brake shoes to wear longer
  4. It makes for a safer brake system
- 6-10. The front piston in a dual master cylinder is known as the primary piston.
1. True
  2. False
- 6-11. What dual master cylinder system operates the brake assemblies on opposite comers?
1. Latitudinal split
  2. Longitudinal split
  3. Diagonal split
  4. Equidistant split
- 6-12. A dual master cylinder with a large front reservoir is an indication of what type of brake system?
1. Latitudinal split
  2. Longitudinal split
  3. Diagonal split
  4. Equidistant split
- 6-13. Where are the residual check valves located in a diagonally split system?
1. In the rear reservoir of the master cylinder
  2. At the wheel cylinder
  3. At the tees that split the system front to rear
  4. In the combination valve
- 6-14. What brake system component changes hydraulic pressure into mechanical force?
1. Wheel cylinder
  2. Master cylinder
  3. Combination valve
  4. Brake drum
- 6-15. What type of wheel cylinder is used to compensate for a faster rate of wear on the front brake shoe?
1. Stepped
  2. Single-piston
  3. Sliding-piston
  4. Double-anchor
- 6-16. Brake lines are constructed from what type of material?
1. Seamless aluminum tubing
  2. Seamed aluminum tubing
  3. Single-wall steel tubing
  4. Double-wall steel tubing
- 6-17. What component is used to feed two-wheel cylinders from a single brake line?
1. Poppet valve
  2. Counterbalance valve
  3. Junction block
  4. Pressure-control block
- 6-18. Which of the following properties is NOT a characteristic of brake fluid?
1. Moisture absorbent
  2. Low freezing point
  3. Noncorrosive
  4. High boiling point

- 6-19. The primary brake shoe is the front shoe and normally has a slightly shorter lining than the secondary shoe.
1. True
  2. False
- 6-20. What type of brake lining does NOT wear the brake drum excessively?
1. Metallise
  2. Semimetallic
  3. Nonmetallic
  4. Metallic
- 6-21. What type of brake shoe adjusting system is operable in both forward and reverse directions?
1. Link
  2. Lever
  3. Chain
  4. Cable
- 6-22. Which of the following actions is a disadvantage of drum brakes?
1. No means of adjustment
  2. Brake fade
  3. Decreased braking distances
  4. Allows excessive cooling air to enter the assembly
- 6-23. Which of the following actions is an advantage of disc brakes?
1. Reduces braking distances
  2. Increases brake fade
  3. Collects asbestos dust in the brake cavity
  4. Dissipates heat through the brake hub
- 6-24. Of the following components, which one is NOT part of a disc brake assembly?
1. Brake pads
  2. Caliper
  3. Brake hub
  4. Rotor
- 6-25. What component of a caliper acts as a spring to retract the piston?
1. Dust boot
  2. Piston seal
  3. Boot seal
  4. Caliper clip
- 6-26. Metal tabs are built into some disc brake pads for the purpose of
1. notifying the operator of worn brakes
  2. allowing easy installation and removal from the caliper
  3. preventing the pads from coming out of the caliper during operation
  4. identifying the type of lining material used on the pads
- 6-27. What are the three type of disc brakes?
1. Semi-fixed caliper, fixed caliper, and sliding caliper
  2. Semi-floating caliper, fixed caliper, and floating caliper
  3. Sliding caliper, semi-floating caliper, and semi-fixed caliper
  4. Fixed caliper, floating caliper, and sliding caliper



- 6-28. What type of caliper is designed to permit equal braking force to be applied to both sides of the rotor?
1. Semi-floating
  2. Semi-fixed
  3. Floating
  4. Fixed
- 6-29. On a dual brake system, what switch warns the operator of a pressure loss on one of the sides?
1. Master cylinder
  2. Stoplight
  3. Combination
  4. Brake warning light
- 6-30. In a combination valve, what valve holds off front disc braking until the rear brakes makes contact with the drums?
1. Proportioning
  2. Metering
  3. Pressure differential
  4. Pressure reducing
- 6-31. In an antilock brake system (ABS), what component modulates the amount of braking pressure (PSI) going to a specific wheel circuit?
1. Trigger wheels
  2. Hydraulic actuator
  3. Wheel speed sensors
  4. ABS computer
- 6-32. During the operation of an antilock brake system, what component measures trigger wheel rotation?
1. Hydraulic actuator
  2. ABS computer
  3. Frequency reducer
  4. Wheel speed sensor
- 6-33. When antilock brakes are in use, you may feel a vibration in the brake pedal.
1. True
  2. False
- 6-34. To develop the additional force required to apply the brakes, most power brake systems use the difference between
1. exhaust manifold vacuum and hydraulic pressure
  2. exhaust pressure and pneumatic vacuum
  3. intake manifold vacuum and atmospheric pressure
  4. manifold air vacuum and exhaust gas pressure
- 6-35. What are the two types of vacuum boosters?
1. Atmospheric suspended and vacuum suspended
  2. Hydraulic suspended and pneumatic suspended
  3. Vacuum suspended and hydraulic suspended
  4. Pneumatic suspended and atmospheric suspended
- 6-36. What component is designed to make vacuum available for a short time to the booster unit should the vehicle have to stop quickly with a stalled engine?
1. Vacuum chamber
  2. Vacuum reservoir
  3. Vacuum valve
  4. Vacuum manifold

- 6-37. Which of the following actions will occur when you check a vacuum power booster for proper operation?
1. The brake pedal will move upwards slightly
  2. The brake pedal move downward slightly then upwards
  3. The brake pedal will move downward slightly
  4. There is NO brake pedal movement
- 6-38. Which of the following conditions will cause a vacuum failure in the power booster, resulting in a hard brake pedal?
1. A collapsed vacuum hose at the exhaust manifold
  2. A broken air valve spring
  3. A broken power piston linkage
  4. A faulty check valve
- 6-39. Should the power steering system fail, what component of a hydraulic power booster retains enough fluid and pressure for at least two brake applications?
1. Hydraulic reservoir
  2. Pressure regulator
  3. Accumulator
  4. Booster valve
- 6-40. The parking/emergency brake must hold a vehicle on any grade.
1. True
  2. False
- 6-41. Emergency brake requirements are listed in what publication?
1. NAVFAC P-300
  2. COMSECONDNCB/  
COMTHIRDNCBINST 11200.1
  3. *Code of Federal Regulations*
  4. *Federal Motor Carrier Safety Regulation Pocketbook*
- 6-42. You are checking the fluid level in a master cylinder. How far should the fluid be from the top of the reservoir?
1. 1/4 inch
  2. 1/8 inch
  3. 1/2 inch
  4. 1/16 inch
- 6-43. The distance from the floor to the brake pedal with the brake applied is known as the brake pedal
1. height
  2. free play
  3. reserve distance
  4. performance distance
- 6-44. Disc brake pads should be replaced when the lining is approximately how thick?
1. 1/32 inch
  2. 1/16 inch
  3. 1/8 inch
  4. 1/4 inch

- 6-45. When reconditioning a master cylinder, you should take what action if the bore is NOT badly pitted or corroded?
1. Install a sleeve in the bore
  2. Hone the cylinder
  3. Machine the bore oversize
  4. Sand the bore using emery cloth
- 6-46. Which of the following tools is NOT used to determine if a master cylinder bore is worn excessively?
1. Outside micrometer
  2. Inside caliper
  3. Feeler gauge
  4. Telescoping gauge
- 6-47. Before installing a master cylinder on a vehicle, you should take what action?
1. Lubricate all parts with denatured alcohol
  2. Remove the inlet ports and check for obstructions
  3. Install the master cylinder clamp
  4. Bench bleed the master cylinder
- 6-48. What action should be taken when you find any pitting, scoring, or scratching in the bore of a wheel cylinder?
1. Replace the wheel cylinder
  2. Hone the cylinder bore
  3. Install a cylinder sleeve
  4. Sand the cylinder bore with emery cloth
- 6-49. Why should you install a wheel cylinder clamp before removing the brake shoes?
1. To facilitate removal of the brake shoe retracting springs
  2. To prevent the loss of brake fluid should someone accidentally depress the brake pedal
  3. To keep dirt out of the cylinder when cleaning the backing plate
  4. To hold the pistons in the wheel cylinder
- 6-50. When the rivet holes in a brake shoe become enlarged, you should take what action?
1. Install oversize rivets
  2. Weld the holes closed and re-drill
  3. Discard the brake shoe
  4. Drill new holes in the shoe
- 6-51. When riveting the lining to a brake shoe, you should start
1. at one end of the lining, then alternately work towards the other
  2. by first riveting both ends, then work alternately toward the center of the lining
  3. at one end and work down one side then the other
  4. in the center and work alternately toward each end of the lining
- 6-52. Normally, what is the maximum amount of surface material that can be removed from a brake drum and still provide adequate braking?
1. .006 inch
  2. .060 inch
  3. .003 inch
  4. .030 inch

- 6-53. What tool should you use to measure the diameter of a brake drum?
1. Brake drum caliper
  2. Brake drum telescoping gauge
  3. Brake drum micrometer
  4. Brake drum circumference gauge
- 6-54. When replacing disc brake shoes, you force the caliper pistons into the bores of the caliper to
1. determine if the pistons are free to move in the caliper
  2. open the caliper wide enough for the new thicker pads
  3. inspect for hydraulic leaks around the piston seal
  4. open the caliper wide enough for the removal of the rust ridge on the disc
- 6-55. What tool should you use to check a brake disc for runout?
1. Micrometer
  2. Outside caliper
  3. Thickness gauge
  4. Dial indicator
- 6-56. When the disc brake runout is beyond the manufacturer's specifications, you should take what action?
1. Resurface the disc
  2. Tighten the wheel bearings
  3. Replace the caliper
  4. Discard the disc
- 6-57. Which of the following defects is the most likely cause of soft, spongy action of the brake pedal in a hydraulic brake system?
1. Faulty pedal return spring
  2. Sticking wheel cylinder
  3. Air trapped in the brake lines
  4. A clogged master cylinder breather
- 6-58. When removing air from the hydraulic brake system, you should bleed one brake at a time starting with the wheel cylinder located
1. nearest to the master cylinder
  2. farthest from the master cylinder
  3. on the left front
  4. on the right front
- 6-59. When you pressure bleed a hydraulic brake system, the bleeder ball should be charged with what amount of air pressure?
1. 5 to 10 psi
  2. 15 to 20 psi
  3. 20 to 25 psi
  4. 10 to 15 psi

- 6-60. The function of the governor in an air brake system is to maintain the air pressure in the reservoir.
1. True
  2. False
- 6-61. The governor maintains the proper pressure required for safe operation by controlling what component?
1. The compressor unloader mechanism
  2. The pilot valves
  3. The pressure differential valve
  4. The spring tube
- 6-62. What gauge should you use to adjust the type O-1 governor accurately?
1. Thickness gauge
  2. Vacuum gauge
  3. Depth gauge
  4. Air pressure gauge
- 6-63. To decrease the pressure range in the type O-1 governor, you may
1. add shims beneath the upper valve guide
  2. remove shims from the upper valve guide
  3. turn the adjusting screw clockwise
  4. turn the adjusting screw counter-clockwise
- 6-64. At what pressure range, within the type D governor, will the air pressure allow the exhaust stem to close the exhaust valve and to open the inlet valve?
1. 80-90 psi
  2. 90-100 psi
  3. 100-110 psi
  4. 110-120 psi
- 6-65. In a type D governor, at what pressure range will the spring loading within the governor overcome the developed force of the air pressure under the diaphragm?
1. 80-85 psi
  2. 90-95 psi
  3. 100-105 psi
  4. 110-115 psi
- 6-66. To increase the pressure setting of the type D governor, you must perform which of the following tasks?
1. Turn the adjusting nut counter-clockwise
  2. Turn the adjusting screw clockwise
  3. Add shims to the inlet valve guide
  4. Remove shims from the inlet valve guide
- 6-67. What is the function of the unloader assembly?
1. To cool, store, and remove moisture from the air
  2. To protect the brake system against excessive pressure
  3. To stop and start compression in the compressor
  4. To control the air pressure that is delivered to the brake chambers
- 6-68. What component is used to cool, store, and remove moisture from the air and give a smooth flow of air to the brake system?
1. Unloader mechanism
  2. Reservoirs
  3. Air pressure diaphragm
  4. Pressure differential mechanism

- 6-69. What is the function of the safety valve located on top of the first reservoir?
1. To prevent moisture buildup in the system
  2. To protect the system against excessive back pressure
  3. To prevent air pressure from reaching it's maximum setting
  4. To protect the system against excessive air pressure
- 6-70. What component is designed to convert the energy of compressed air into mechanical force and motion?
1. Brake valve
  2. Brake chamber
  3. Brake cylinder
  4. Brake diaphragm
- 6-71. What component provides a quick and easy way to adjust air brakes to compensate for wear?
1. Brake camshaft
  2. Adjusting screw
  3. Pushrod adjuster
  4. Slack adjuster
- 6-72. What valve controls the air pressure delivered to the brake chambers?
1. Tractor protection
  2. Quick release
  3. Treadle
  4. Limiting
- 6-73. After cleaning a treadle valve, you should apply which of the following lubricants to the internal parts of the valve during reassembly?
1. Engine oil
  2. Chassis lube
  3. Bearing grease
  4. Vaseline
- 6-74. What valve is designed to exhaust brake chamber air pressure and speed up brake release of the air brake system?
1. Quick release
  2. Treadle
  3. Safety
  4. Trailer control
- 6-75. In a quick-release valve, as air pressure above the diaphragm is released, the air pressure below raises the diaphragm off the exhaust port. This action allows air in the brake chamber to exhaust at the quick-release valve.
1. True
  2. False

## ASSIGNMENT 7

Textbook Assignment: "Brakes" (continued) and "Automotive Chassis and Body," chapters 7 and 8, pages 7-40 through 8-29.

---

- 7-1. What valve has the same type of mounting as the quick-release valve?
1. Safety
  2. Tractor protecting
  3. Relay emergency
  4. Combined limiting and quick release
- 7-2. What valve functions as a set of remotely controlled cutout valves for normal and emergency air brake operations?
1. Relay
  2. Tractor protection
  3. Relay emergency
  4. Safety
- 7-3. Of the following functions, which one is NOT a function of the relay emergency valve in an air brake system?
1. To speed up the application of the trailer brakes
  2. To speed up the release of the trailer brakes
  3. To apply the trailer brakes when the emergency line of the trailer is broken
  4. To protect the tractor air brake system under trailer breakaway conditions
- 7-4. What is the function of the relay emergency valve during normal operation of a tractor-trailer unit?
1. To protect the tractor air brake system under conditions of when severe leakage develops in the tractor or trailer
  2. To increase the air pressure in a designated area to speed up the application and release of the trailer brakes
  3. To synchronize trailer service brake air pressure and tractor service air brake pressure during treadle valve operation
  4. To control the air pressure that is delivered to the brake chambers of the trailer
- 7-5. If the brakes engage when the emergency line is removed from a charged trailer system, the relay emergency valve is functioning properly.
1. True
  2. False
- 7-6. What is the function of the dummy couplings?
1. To allow air to leave a unit while preventing dirt from entering
  2. To prevent dirt and moisture from entering unused air lines
  3. To increase air pressure to speed up application and release of the trailer brakes
  4. To conserve air pressure

- 7-7. Anytime the air pressure is within the normal operating range, the low-pressure warning indicator will
1. remain open
  2. remain closed
  3. open and close intermittently
  4. begin to flash and buzz
- 7-8. The contacts on an air brake system stoplight switch will close when subjected to a minimum air pressure of
1. 5 psi
  2. 10 psi
  3. 15 psi
  4. 20 psi
- 7-9. To test for leakage of various components within the air brake system, you should use
1. water
  2. a very light-weight oil
  3. a thick mixture of soapsuds
  4. any water-free liquid
- 7-10. The air-hydraulic-power cylinder (Air-Pak) is composed of which of the following components?
1. Master cylinder, compressed air cylinder, and slave cylinder
  2. Slave cylinder, control valve, and master cylinder
  3. Control valve, compressed air cylinder, and slave cylinder
  4. Compressed air cylinder, control valve, and master cylinder
- 7-11. What component of the Air-Pak houses the residual check valve?
1. Control valve
  2. Master cylinder
  3. Slave cylinder
  4. Compressed air cylinder
- 7-12. Forward movement of the piston in the compressed air cylinder is dependent upon
1. brake pedal pressure
  2. hydraulic pressure
  3. spring pressure
  4. air pressure
- 7-13. In an air-over-hydraulic brake system, fluid pressure in the brake lines is always in direct ratio to the
1. amount of air pressure entering the compressed air cylinder
  2. resultant hydraulic pressure admitted to the air cylinder
  3. pressure forcing the power piston forward
  4. foot pressure on the brake pedal
- 7-14. In an air-over-hydraulic brake system, the degree of brake application is determined by the amount of compressed air trapped in the power cylinder when brake pedal movement is stopped.
1. True
  2. False



- 7-15. When the brake pedal is released, what force returns the power piston to the released position?
1. Air
  2. Spring
  3. Hydraulic
  4. Air-over-hydraulic
- 7-16. Which of the following requirements is NOT satisfied by the components of the vehicle chassis?
1. Support the vehicle and its payload
  2. Provide for directional control
  3. Allow smooth operation over rough terrain
  4. Enclose the mechanical components and passenger compartment
- 7-17. What is the function of the cross members in a frame assembly?
1. To reduce vibration
  2. To add extra strength at the joints
  3. To prevent weaving and twisting of the frame
  4. To support the payload of the vehicle
- 7-18. In a typical passenger vehicle, the frame supplies 37 percent of the torsional rigidity and 34 percent of the bending rigidity with the balance supplied by the body.
1. True
  2. False
- 7-19. The side members of many passenger vehicle frames are closer together in the front than in the rear in order to
1. supply more rigid support for the engine
  2. allow the vehicle to make sharper turns
  3. supply a more rigid support for the front wheels
  4. reduce vibration from the engine
- 7-20. What type of frame construction allows an increase in the amount of noise transmitted into the passenger compartment?
1. Ladder
  2. Integrated
  3. Separated
  4. Jack
- 7-21. The suspension system of a vehicle is NOT designed to
1. support the weight of the vehicle
  2. allow the vehicle to be driven with varying loads
  3. allow the vehicle to travel over various type of terrain
  4. allow body squat when accelerating with a heavy load
- 7-22. What component of the suspension system prevents the control arm from swinging to the front or rear of the vehicle?
1. Control arm bushings
  2. Strut rod
  3. Stabilizer bar
  4. Strut

- 7-23. The control arm of a vehicle has bushings on the inner end. What suspension component is attached to the outer end?
1. Shock absorber
  2. Strut
  3. Ball joint
  4. Stabilizer bar
- 7-24. What movement allows the steering knuckle and wheel to be turned left or right and move up and down with changes in road surface?
1. Compression and rebound of the shock absorber
  2. Swiveling action of the ball joints
  3. Lateral movement of the control arms
  4. Horizontal movement of the strut rods
- 7-25. In a vehicle equipped with MacPherson struts, the strut assembly replaces the
1. upper control arm
  2. lower control arm
  3. upper damper unit
  4. steering knuckle
- 7-26. In a vehicle equipped with MacPherson struts, what components are required to support the front-wheel assembly?
1. Strut assembly and lower control arm
  2. Steering knuckle and upper damper unit
  3. Strut assembly and upper damper unit
  4. Steering knuckle and lower control arm
- 7-27. What term refers to the stiffness or tension of a spring?
1. Elastic tolerance
  2. Spring ratio
  3. Elastic deformation
  4. Spring rate
- 7-28. Which of the following components do NOT add to the unsprung weight of a vehicle?
1. Wheels
  2. Axles
  3. Rims
  4. Body
- 7-29. As a vehicle goes over a bump, its multileaf springs are held together by the
1. spring shackles
  2. rebound clips
  3. bumper blocks
  4. clip plates
- 7-30. What is the purpose of an auxiliary spring?
1. To offset the effect of a weak main spring
  2. To prevent braking of the main spring
  3. To eliminate the danger of overloading
  4. To provide additional support for heavy loads

- 7-31. What component in a bogie suspension system distributes the rear load evenly to the axles?
1. Cross shaft
  2. Trunnion axle
  3. Springs
  4. Torque rods
- 7-32. What suspension component when worn will make a clunking or popping sound when the vehicle is turning or driving over a bump?
1. Ball joint
  2. Strut rod
  3. Control arm
  4. Torsion bar
- 7-33. What tool is used to measure the axial play of a ball joint?
1. Spring gauge
  2. Micrometer
  3. Dial indicator
  4. Outside caliper
- 7-34. A loose shock absorber will produce what type of sound?
1. Loud popping
  2. Loud banging
  3. Loud snapping
  4. Loud clunking
- 7-35. In general, a good shock absorber should stop movement in two to three rebounds.
1. True
  2. False
- 7-36. What action should be taken when you notice a damaged shock absorber on the rear of the vehicle?
1. Replace the damaged shock absorber
  2. Replace all shock absorbers on the vehicle
  3. Replace both rear shock absorbers
  4. Install a helper spring to aid the damaged shock absorber
- 7-37. What condition lowers the height of the vehicle, allowing the body to settle towards the axles?
1. Faulty struts
  2. Spring fatigue
  3. Weak shock absorbers
  4. Worn control arm bushings
- 7-38. What measurement is used to check the condition of the springs?
1. Vehicle height
  2. Spring height
  3. Curb height
  4. Body height

- 7-39. What two factors are used to determine steering ratio?
1. Steering linkage ratio and steering mechanism gear ratio
  2. Turning ratio and steering linkage ratio
  3. Steering mechanism gear ratio and diameter of the pinion gear
  4. Diameter of the worm gear and diameter of the pinion gear
- 7-40. Of the following systems, which one is NOT a type of manual steering?
1. Cam and lever
  2. Rack and pinion
  3. Sector and lever
  4. Worm and nut
- 7-41. In a worm and sector steering gear, the pitman arm carries the sector gear and the worm gear is carried on the steering gear shaft.
1. True
  2. False
- 7-42. The design of the worm and roller steering gear provides a
1. high steering ratio
  2. low steering ratio
  3. medium steering ratio
  4. variable steering ratio
- 7-43. What action within a cam and lever steering gear causes the lever and pitman arm to rotate?
1. The rotation of the camshaft
  2. The angle of the lever in relation to the cam
  3. The movement of the studs on the cam
  4. The cam screwing up and down on the camshaft
- 7-44. What is the most common type of worm and nut steering gear?
1. Rolling ball
  2. Rotating ball
  3. Recirculating ball
  4. Reducing ball
- 7-45. In a manual rack-and-pinion steering gear, what component preloads the rack-and-pinion gear teeth to prevent excessive backlash?
1. Thrust plate
  2. Thrust spring
  3. Thrust washer
  4. Thrust bearing
- 7-46. In a rack-and-pinion steering gear, the rack is connected to the steering arm by what steering linkage component?
1. Strut rod
  2. Tie rods
  3. Center link
  4. Idler arms

- 7-47. The oil flow with a power steering system is directed by the
1. hydraulic pump
  2. power cylinder
  3. control valve
  4. hydraulic gear housing
- 7-48. What are the three types of power steering systems?
1. Internal rotor, external spool, and rack and pinion
  2. Internal spool, external slipper, and rack and pinion
  3. Integral cylinder, external piston, and rack and pinion
  4. Integral piston, external cylinder, and rack and pinion
- 7-49. What is the most common type of power steering system?
1. Integral piston
  2. Integral cylinder
  3. Internal spool
  4. Internal rotor
- 7-50. With the steering wheel in the straight-ahead position, what valve in the integral power steering system balances hydraulic pressure on both sides of the power piston?
1. Relief
  2. Flow
  3. Shuttle
  4. Control
- 7-51. The spool type control valve used in a power rack-and-pinion steering system is operated by the
1. torsion bar connected to the pinion gear
  2. thrust action of the pinion shaft
  3. hydraulic piston attached to the center of the rack
  4. power cylinder connected to the rack
- 7-52. In a power rack-and-pinion steering system, what action moves the rotary type control valve to align specific oil passages?
1. Twisting of the torsion bar
  2. Thrusting of the pinion shaft
  3. Movement of the power cylinder
  4. Oil pressure acting on the power piston
- 7-53. When you check an idler arm for wear, as a general rule the idler arm should NOT move up and down more than
1. 1/8 inch
  2. 1/2 inch
  3. 1/3 inch
  4. 1/4 inch
- 7-54. When replacing tie-rod ends, you should take what action once the tie rod has been removed from the steering knuckle?
1. Measure steering knuckle length
  2. Measure tie-rod length
  3. Measure curb height
  4. Measure front-end alignment

- 7-55. What are the two basic adjustments that may be made on a manual steering gearbox?
1. Over-center clearance and worm bearing preload
  2. Sector bearing preload and pinion clearance
  3. Pinion shaft preload and worm shaft clearance
  4. Cam clearance and lever bearing preload
- 7-56. When adjusting a manual steering gearbox, you should first adjust the over-center clearance and then the worm bearing preload.
1. True
  2. False
- 7-57. When adjusting the worm bearing preload, you should use what tool to measure the amount of force required to turn the steering wheel to the center position?
1. Centering gauge
  2. Pressure scale
  3. Spring scale
  4. Wheel measuring gauge
- 7-58. You should take what action if the steering wheel binds after you have performed a worm bearing preload adjustment on a manual steering gearbox?
1. Readjust the worm bearing preload
  2. Continue with the over-center clearance adjustment
  3. Replace the gearbox
  4. Loosen the worm bearing locknut
- 7-59. To find the center position of a steering wheel, turn the steering wheel from full right to full left while counting the turns and divide by two.
1. True
  2. False
- 7-60. The rack guide adjustment screw in a rack-and-pinion steering system is adjusted when there is
1. no play in the steering
  2. excessive play in the control valve
  3. no play in the power cylinder
  4. excessive play in the steering
- 7-61. Which of the following power steering system services will you NOT routinely perform?
1. Check fluid level
  2. Check belts
  3. Check for leaks
  4. Pressure test hoses
- 7-62. When you perform a pressure test on a power steering system, the shut-off valve should NOT be closed for more than
1. 5 seconds
  2. 10 seconds
  3. 15 seconds
  4. 20 seconds
- 7-63. Of the following problems, which one is NOT common to the steering system?
1. Hard steering
  2. Steering wheel play
  3. Steering wheel vibration
  4. Abnormal sounds when turning

7-64. You should NOT be able to turn the steering wheel more than 1 1/2 inches without causing the front wheels to move.

1. True
2. False

7-65. Which of the following steering problems may be caused by improper frame alignment?

1. Excessive steering wheel play
2. Abnormal noises when turning
3. Hard steering
4. Steering wheel vibration

## ASSIGNMENT 8

Textbook Assignment: "Automotive Chassis and Body" (continued), chapter 8, pages 8-29 through 8-58.

---

- 8-1. What are the two basic functions of a tire?
1. To support the weight of the vehicle and provide adequate traction
  2. To act as a cushion between the road and the wheel and provide adequate traction on any road
  3. To prevent road shock from being felt in the passenger compartment and provide adequate traction.
  4. To provide a means to control the vehicle and to provide traction
- 8-2. What part of the tire has two steel rings encased in rubber that holds the sidewalls against the rim?
1. Body plies
  2. Tire bead
  3. Belts
  4. Liner
- 8-3. What part of the tire is used to stiffen the tread and strengthen the plies?
1. Tire beads
  2. Sidewall
  3. Liner
  4. Belts
- 8-4. What type of tire has the plies running at an angle from bead to bead?
1. Bias ply
  2. Radial
  3. Belted bias
  4. Belted radial
- 8-5. What is a major disadvantage of a bias-ply tire?
1. The strength of the plies decrease traction
  2. It provides a rough ride on smooth roads
  3. The body of the tire is too rigid
  4. It increases rolling resistance
- 8-6. In a belted bias tire, what part is added to increase tread stiffness?
1. Stabilizer cord
  2. Stabilizer ply
  3. Stabilizer belt
  4. Stabilizer liner
- 8-7. A radial tire has plies running
1. straight across from bead to bead with stabilizer belts directly beneath the tread
  2. from the sidewall at different angles than the stabilizer belts
  3. at an angle from bead to bead with a stabilizer belts between each ply
  4. straight across from the sidewall with the stabilizer belts at a different angle
- 8-8. What is the major disadvantage of a radial tire?
1. It produces a softer ride at high speeds
  2. It produces a harder ride at high speeds
  3. It produces a harder ride at low speeds
  4. It produces a softer ride at low speed



- 8-9. Which of the following types of information will you NOT locate on the sidewall of a tire?
1. Tire size
  2. Mileage range
  3. Treadwear rating
  4. Inflation pressure
- 8-10. What information is presented in a letter-number sequence on the sidewall of a tire?
1. Tire size
  2. Treadwear rating
  3. Speed rating
  4. Load index
- 8-11. A tire has an alphanumeric tire size rating. What does the first number indicate?
1. Temperature rating
  2. Aspect ratio
  3. Load index
  4. Speed rating
- 8-12. A tire has a P-metric tire size-rating system. What does the letter "P" indicate?
1. Pneumatic
  2. Ply rating
  3. Passenger
  4. Performance
- 8-13. The comparison of the height of the tire to the width of the tire is known as
1. section width
  2. aspect ratio
  3. load index
  4. treadwear rating
- 8-14. What factors determine how much of a load a tire can safely carry?
1. Load range and speed index
  2. Load index and aspect ratio
  3. Load range and the grade of the tire
  4. Load index and proper inflation pressure
- 8-15. For every 10 degrees Fahrenheit change in ambient temperature, the inflation pressure of a tire will change by
1. 1 psi
  2. 2 psi
  3. 3 psi
  4. 4 psi
- 8-16. What government agency requires each tire manufacturer to grade its tires under the Uniform Tire Quality Grade (UTQG) labeling system?
1. National Transportation Safety Board (NTSB)
  2. Department of Highway and Motor Vehicle Safety (HMVS)
  3. Department of Transportation (DOT)
  4. Federal Highway Administration (FHA)

8-17. When you are comparing tires of the same brand, what rating factor provides the most accurate information?

1. Load rating
2. Temperature resistance rating
3. Traction rating
4. Treadwear rating

8-18. In 1997, what traction rating was introduced to indicate a greater wet braking traction?

1. A
2. A+
3. AA
4. AAA

8-19. What temperature resistance grade is the minimum level of performance for all passenger vehicle tires?

1. B
2. D
3. A
4. C

8-20. Uniform Tire Quality Grade (UTQG) ratings are not required for light truck and commercial tires.

1. True
2. False

8-21. For easy identification, a butyl type synthetic rubber tube has a stripe on it that is what color?

1. Green
2. Blue
3. Red
4. White

8-22. Of the following wheel designs, which one is NOT a common design?

1. Flat
2. Drop center
3. Semidrop center
4. Split

8-23. What is the most common type of wheel used on passenger vehicles?

1. Semidrop center
2. Split
3. Safety
4. Drop center

8-24. A lug nut has the letter "M" stamped into it, what does the "M" indicate?

1. Military thread
2. Multipurpose thread
3. Metric thread
4. Machine thread

8-25. In a nondriving wheel bearing and hub assembly, what component extends outward from the steering knuckle?

1. Hub
2. Outer drive axle
3. Spindle
4. Bearing support

8-26. In a driving wheel bearing and hub assembly, what component extends through the wheel bearings and is splined to the hub?

1. Spindle
2. Outer drive axle
3. Steering knuckle
4. Axle locknut

8-27. Using a plug to attempt a tire repair without dismounting the tire is effective only what percentage of the time?

1. 50
2. 60
3. 70
4. 80

8-28. You should NOT attempt to repair a tubeless tire that has a puncture that is larger than

1. 1/16 inch
2. 1/8 inch
3. 1/4 inch
4. 1/2 inch

8-29. When removing an object from a tire, you should reduce the air pressure to at least

1. 20 psi
2. 15 psi
3. 10 psi
4. 5 psi

8-30. What are the two methods used to patch an inner tube?

1. Cold-patch and chemical vulcanizing
2. Chemical-vulcanizing and heat shrink
3. Hot-patch and chemical fusion
4. Cold-patch and hot-patch

8-31. How often should tires be rotated?

1. Once a month
2. Once a quarter
3. Yearly
4. 3,000 to 5,000 miles

8-32. Refer to figure 8-41 in the textbook. what pattern is used when you are rotating the tire on a vehicle that has directional tires?

1. E
2. D
3. C
4. A

- 8-33. What type of tire imbalance will cause the tire to vibrate up and down and from side to side?
1. Static
  2. Radius
  3. Dynamic
  4. Spiral
- 8-34. A wheel and tire assembly that has its weight evenly distributed around the axis of rotation is known to be in
1. static balance
  2. radius balance
  3. dynamic balance
  4. spiral balance
- 8-35. If a large amount of weight is required to static balance a wheel and tire assembly, you should distribute the weight in what manner?
1. Add half to the outside and half to the inside
  2. Add a quarter to the outside and the rest to the inside
  3. Add a quarter to the inside and the rest to the outside
  4. Add exactly where needed
- 8-36. What is the most common type of balancer used by the NCF?
1. Spin balancer
  2. On-the-vehicle balancer
  3. Bubble balancer
  4. Computerized balancer
- 8-37. Of the following types of tire damage, which one is NOT considered impact damage?
1. Tears
  2. Punctures
  3. Cuts
  4. Splits
- 8-38. What is the most probable cause for the center of a tire to wear faster than the outer area?
1. Erratic scrubbing against the road
  2. Over inflation
  3. Excessive camber
  4. Faulty ball joints
- 8-39. What type of tread wear pattern is caused by excessive camber?
1. Feathering
  2. Cupping
  3. One-side wear
  4. Cornering wear
- 8-40. The vehicle you are driving has a tendency to pull to the left. What is the most probable cause of this problem?
1. Right tire ply separation
  2. Under inflated left tire
  3. Over inflated left tire
  4. Imbalanced right tire

- 8-41. Maximum tire life depends mainly on what factor?
1. Manufacturer
  2. Regular rotation
  3. Proper inflation
  4. Operating conditions
- 8-42. Correct wheel alignment is essential to vehicle safety, handling, extending tire life, and achieving maximum fuel economy.
1. True
  2. False
- 8-43. What type of alignment ensures that the wheels are "squared" to each other?
1. Front-end alignment
  2. Frame alignment
  3. Thrust angle alignment
  4. Steering alignment
- 8-44. Of the following steering angles, which one is NOT a tire wear angle?
1. Caster
  2. Camber
  3. Toe-out on turns
  4. Tracking
- 8-45. As a general rule, vehicles with power steering should have positive caster.
1. True
  2. False
- 8-46. Negative caster tilts the top of the steering knuckle towards the
1. rear of the vehicle
  2. front of the vehicle
  3. right side of the vehicle
  4. left side of the vehicle
- 8-47. Of the following functions, which one is NOT a function of camber?
1. To aid steering by placing vehicle weight on the inner end of the spindle
  2. To prevent tire wear on the inner or outer tread
  3. To load the larger inner wheel bearing
  4. To offset road crown pull
- 8-48. When performing a wheel alignment, you make a slight positive camber setting. As a general rule, the setting you make should be between
1. 1/16 to 1/8 degree
  2. 1/8 to 1/4 degree
  3. 1/4 to 1/2 degree
  4. 1/2 to 3/4 degree

- 8-49. What wheel alignment angle is determined by the difference in the distance between the front and the rear of the left and right wheels?
1. Steering axis inclination
  2. Toe
  3. Tracking
  4. Toe-out on turns
- 8-50. Of the following alignment angles, which one is considered to be the most critical?
1. Caster
  2. Camber
  3. Tracking
  4. Toe
- 8-51. When you are performing a wheel alignment on a front-wheel drive vehicle, what amount of toe-out is required?
1. 1/16 inch
  2. 1/8 inch
  3. 1/4 inch
  4. 1/2 inch
- 8-52. Steering axis inclination is NOT adjustable because it is designed into the suspension of the vehicle.
1. True
  2. False
- 8-53. When performing a wheel alignment, you should take what action to correct the steering axis inclination angle?
1. Adjust the suspension system
  2. Replace damaged or worn suspension components
  3. Change the angle of the steering control arm
  4. Adjust the steering mechanism
- 8-54. You are performing a wheel alignment and discover that the toe-out on turns angle is incorrect. This condition is a good indication that what problem exists?
1. Wrong size tires
  2. Worn ball joints
  3. Misadjusted steering mechanism
  4. Damaged steering components
- 8-55. What steering geometry angle maintains a right angle between the center line of the vehicle and both front and rear axles?
1. Toe-out on turns
  2. Steering axis inclination
  3. Tracking
  4. Caster

8-56. Which of the following conditions will cause improper tracking?

1. Bent rear axle mount
2. Bent control arm
3. Broken shock mount
4. Loose sway bar

8-57. When checking toe-out on turns using a turning radius gauge, you must turn one of the front wheels until the gauge reads

1. 10 degrees
2. 15 degrees
3. 20 degrees
4. 25 degrees

8-58. When performing a front-end alignment, you must align both caster and camber together because one affects the other.

1. True
2. False

8-59. You are making a toe adjustment to the tires of a vehicle. To compare the distance between the front and rear of the tires, you should use what tool?

1. Tape measure
2. Tram gauge
3. Philadelphia rod
4. Tri-square

8-60. You should use what tools to remove surface defects on dolly blocks?

1. Grinder and crocus clothe
2. Rasp and course grit sandpaper
3. File and tine grit sandpaper
4. Sanding block and medium grit sandpaper

8-61. When repairing a damaged vehicle, you force the damaged area to return to a near original shape by using a

1. spoon
2. hammer
3. body straightener
4. portable hydraulic jack

8-62. When using a hammer and dolly to remove a body dent, you should

1. work from the point of impact to the center
2. work the ridge farthest from the point of impact
3. work from the center to the point of impact
4. work the ridge closest to the point of impact

8-63. Body hammers with crowned faces should only be used to make repairs to what type of surfaces?

1. Dimpled
2. Flat
3. Convex
4. Concave

- 8-64. What is the most important factor to be considered before a heavily damaged body panel is repaired?
1. Overall time and labor cost
  2. Damaged area of the body panel
  3. Direction of force that caused the damage
  4. Amount of materials on hand
- 8-65. When welding a new piece of sheet metal on a damaged vehicle, you can ensure a reduction in distortion by
1. using a small torch tip
  2. working from the bottom up
  3. allowing the metal to cool between welds
  4. staggering the welds
- 8-66. You are prepping a vehicle that is in good condition for painting. To remove any scratches, you should use abrasive paper that is what size?
1. 50 grit
  2. 150 grit
  3. 280 grit
  4. 320 grit
- 8-67. What is the preferred method for removing paint from the entire surface of a vehicle?
1. Chemical removal
  2. Sandblasting
  3. Acid bath
  4. Heat guns
- 8-68. What action should be taken to prevent deterioration of exposed sheet metal due to an accident?
1. Refinish the entire vehicle
  2. Refinish the damaged side
  3. Refinish the damaged panel
  4. Spot paint only
- 8-69. When you are refinishing a vehicle, what type of problem will high-viscosity paint create?
1. Runs
  2. Improper flow-out
  3. Orange peel
  4. Poor adherence to the surface
- 8-70. What distance should the spray gun be held from the surface to be painted to obtain optimum coverage?
1. 2 to 6 inches
  2. 4 to 8 inches
  3. 6 to 10 inches
  4. 8 to 12 inches
- 8-71. What is the recommended thickness for a layer of epoxy filler?
1. 1/16 inch
  2. 1/8 inch
  3. 1/4 inch
  4. 3/8 inch



8-72. What publication contains information on the placement of registration numbers on a piece of CESE?

1. NAVFAC P-434
2. NAVFAC P-307
3. NAVFAC P-300
4. NAVFAC P-237





